

6-Axis Robot Quick Changer Adaptor

(Dimensioned drawings shown half scale)

Fastens to Quick Changer for easy Mounting of Gimatic, >ASS<, and 80/20 Profiles

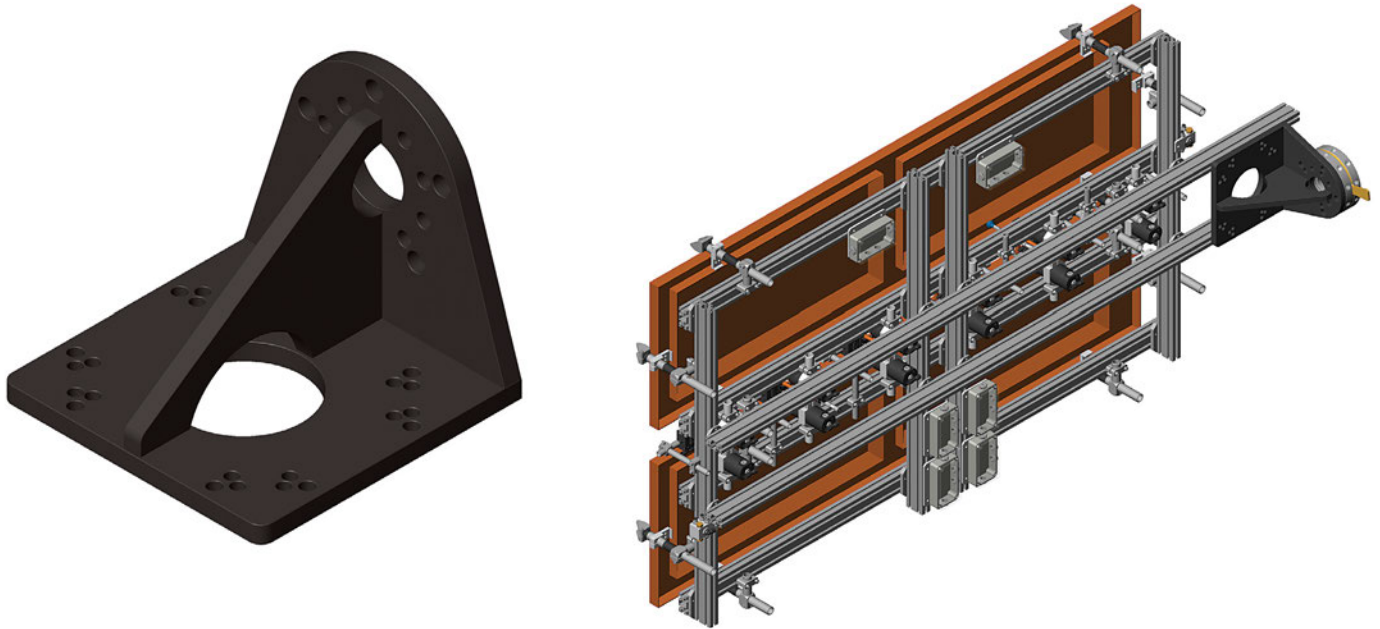

6-Axis Robot Adaptor Bracket

Quick#	Part#	Price	Quick Changer	Weight
1899	GSC-QCAP-L90SM	\$423.00	Standard (QC90)	1120g
1871	GSC-QCAP-L90	\$488.00	Large (QC150 / QC160)	3401g

#1899

