

Parallel Pneumatic Gripper – T

- Double acting
- Self-centering
- Air feeding accessible directly from the fixing plate.
- Possible to mount it on front with through screws.
- High gripping force with low weight.
- See Sensor Reference Guide on page 1010 for a complete list of compatible sensors.



Quick#	6284	6285	6286
Part#	T30	T40	T63
Price	\$489.00	\$591.00	\$698.00
Medium	Filtered, lubricated / non lubricated compressed air		
Pressure range	36–116 psi		
Repeatability	±0.02mm	±0.02mm	±0.02mm
Closing time without load	0.01s	0.01s	0.05s
Maximum working frequency	4Hz	3Hz	2Hz
Air consumption per cycle	12cm ³	19cm ³	94cm ³
Stroke (±0.2mm)	3x3mm	3x5mm	3x9mm
Opening gripping force at 87 psi	77.4 lbf	135 lbf	324 lbf
Closing gripping force at 87 psi	70.8 lbf	121.5 lbf	297 lbf
Mid-stroke detection capability	Yes, see Sensor Reference Guide on page 1010 for details.		
Weight	325g	745g	1680g

For more information visit: www.EMlcorp.com

Parallel Pneumatic Gripper – T

T30, T40, & T63

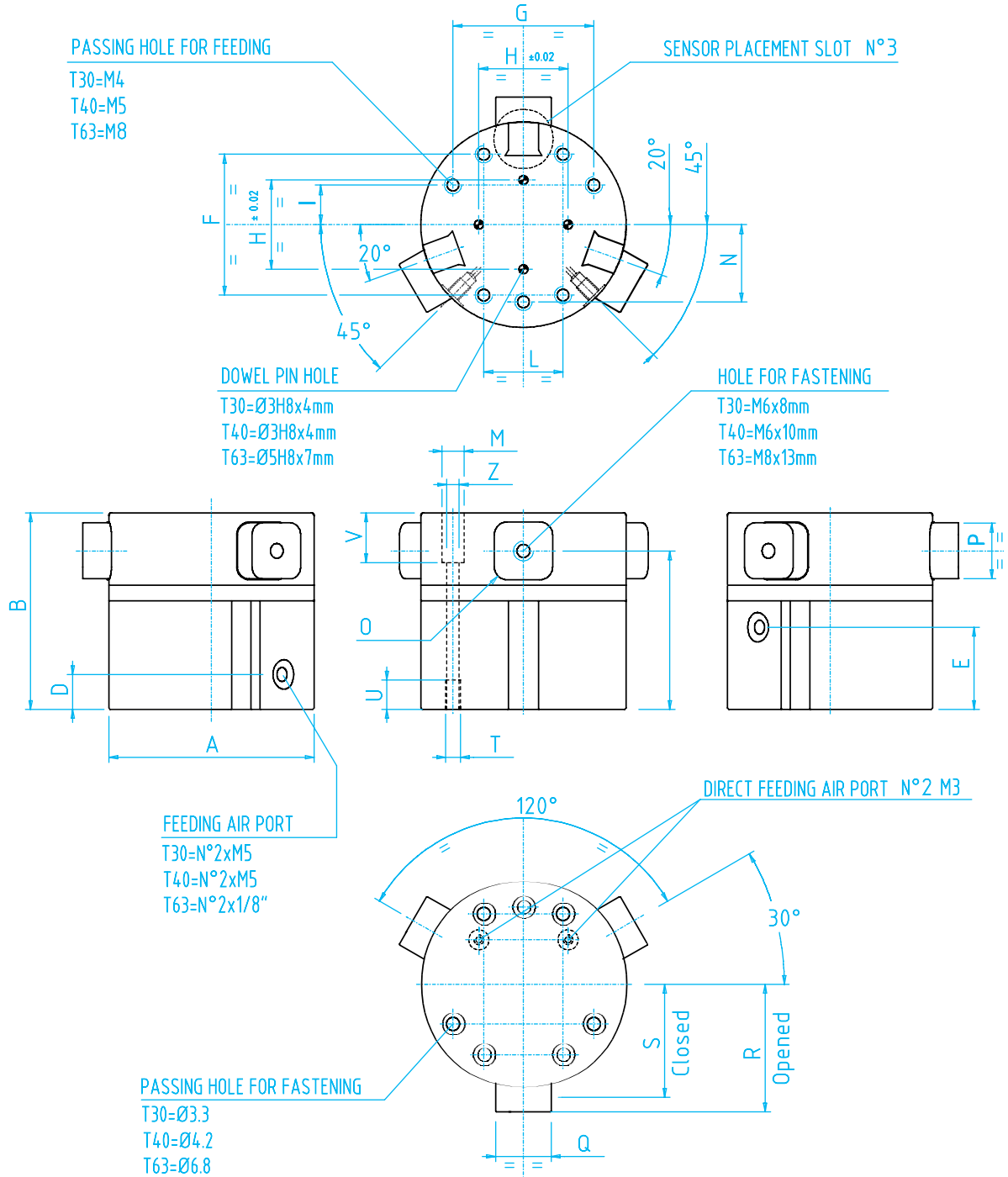

	A	B	C	D	E	F	G	H ±0.02	I	L	M	N	O	P -0.05	Q -0.05	R	S	T	U	V	Z
T30	ø50	59	49.5	8	27	37	-	30.4	-	21	ø6	-	3	14	14	30.5	27.5	M4	8	14	ø3.3
T40	ø70	67	54	11.9	28	48	48	30.4	13.5	27	ø7.5	26.3	4	19	19	43.6	38.5	M5	10	17	ø4.2
T63	ø90	90.5	72.8	12	38	66	-	59	-	38	ø10.5	-	5	26	26	60.6	51.5	M8	16	28.5	ø6.8