

# EOAT Mounting Plate for Standard Size (90mm) Quick Changers

(Dimensioned drawing shown full scale)

Use with 90mm Quick Changers to Mount to >ASS<, Gimatic, and 80/20 Profile

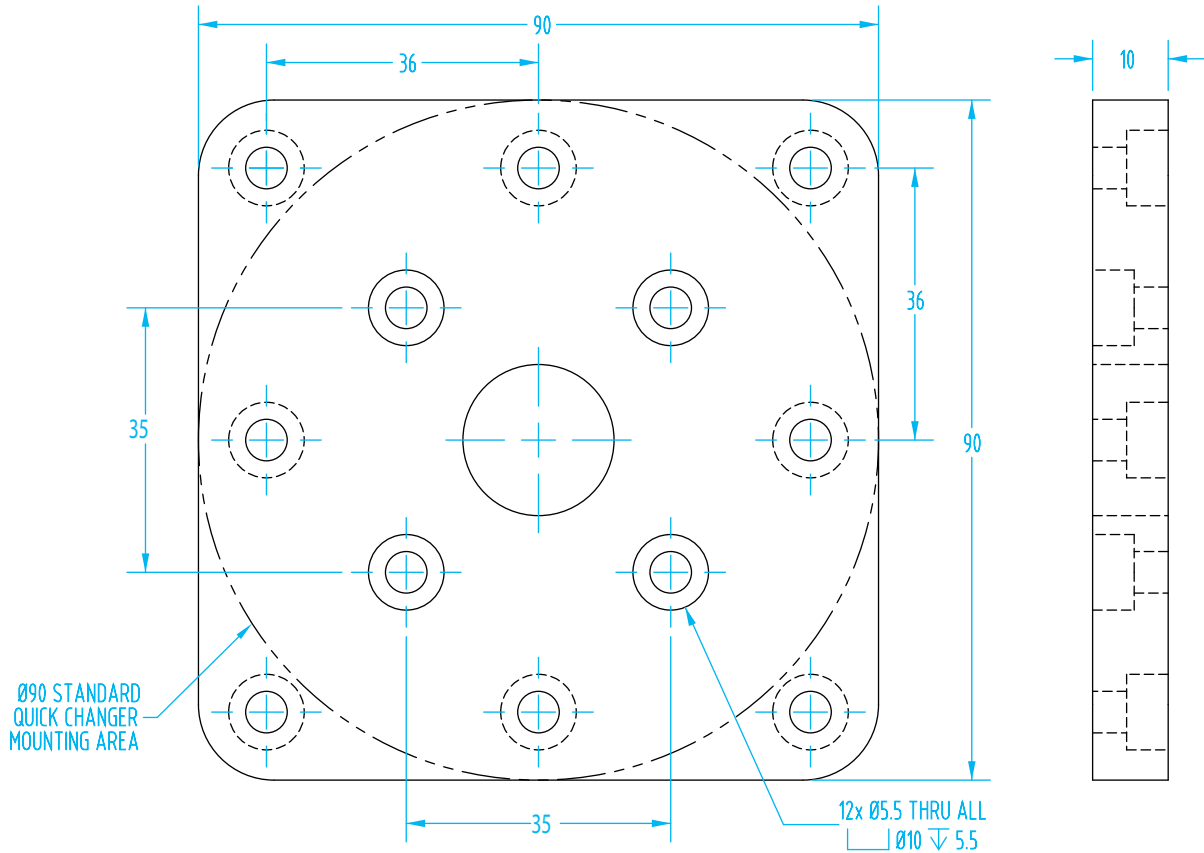

Standard Size (90mm) EOAT Mounting Plate

Quick#	Part#	Price	Weight
757	GSC-QCAP-1	\$32.00	191g

## Application Examples

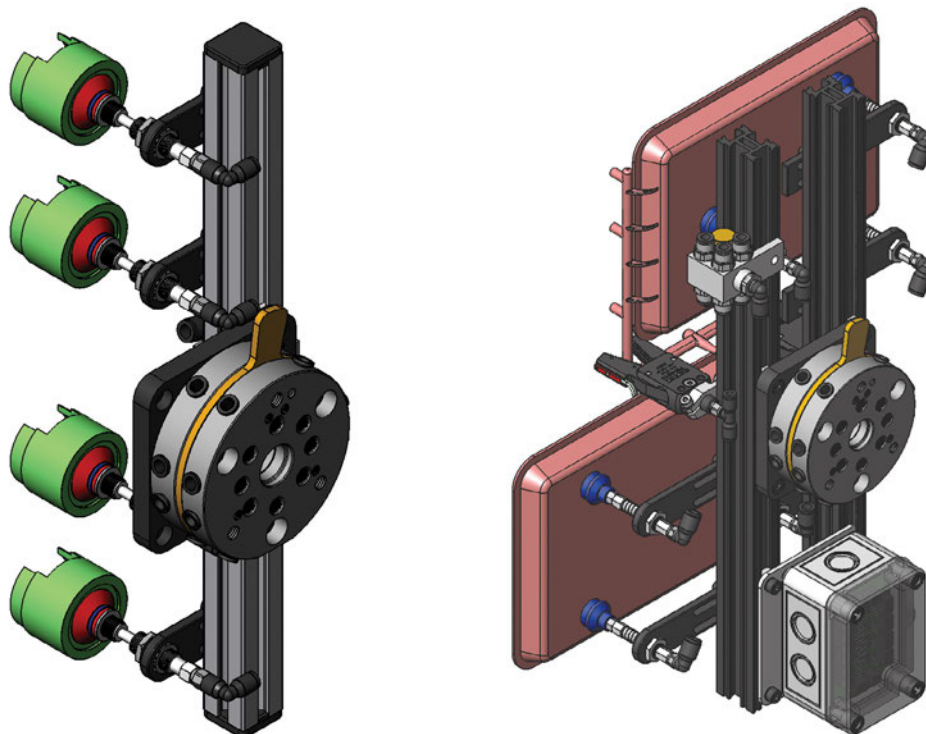

## Blank EOAT Mounting Plate for Standard Size (90mm) Quick Changers

(Dimensioned drawing shown full scale)

### Basic Blank Mounting Plate for Custom Mount

This anodized aluminum plate can be used as a manual EOAT mounting plate to adapt profiles as shown on page 40. It is scored with a center line making it easy to locate holes for mounting to your robot tooling plate. There is plenty of space on this plate to drill or tap holes as necessary. Pre-drilled and counter-bored holes simplify mounting to profile.



Standard Size (90mm) EOAT Mounting Plate

Quick#	Part#	Price	Weight
753	GSC-QCAP-1B	\$35.86	205g

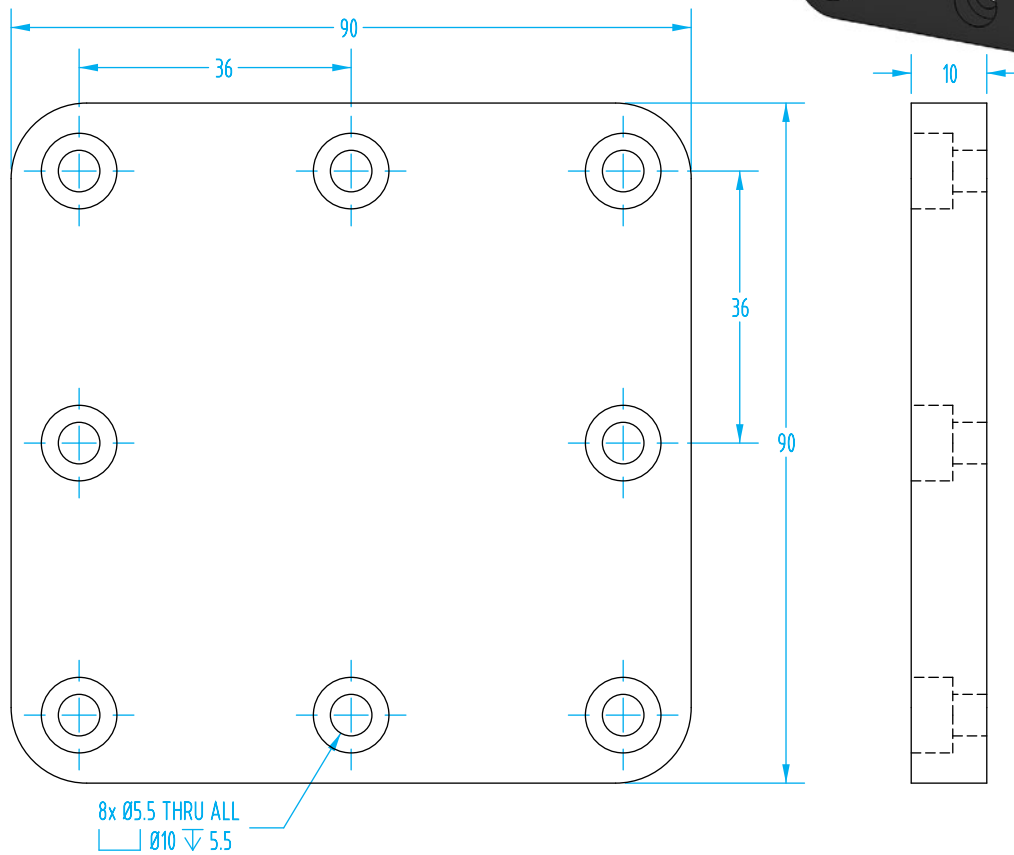

Cobot mounting plates with ISO-9409-1-50-4-M6 mounting pattern on page 124.

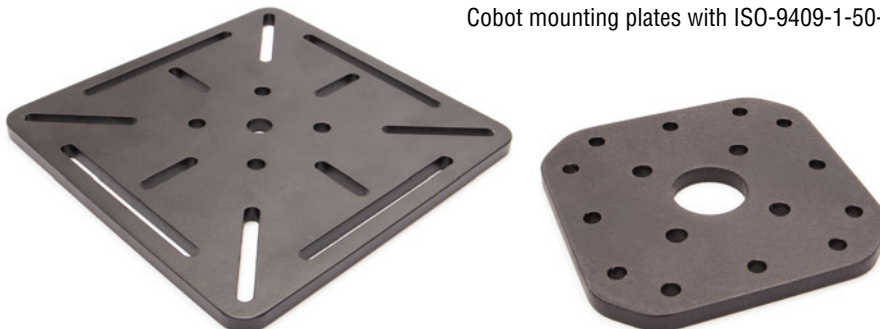

# EOAT Mounting Plate for Standard Size (90mm) Quick Changers

(Dimensioned drawing shown full scale)

Use with **90mm Quick Changers** to Mount to >ASS<, Gimatic, and 80/20 Profile

Standard Size (90mm) EOAT Mounting Plate

Quick#	Part#	Wt.	Price	Notes
1664	GSC-QCAP-2	553g	\$42.80	For >ASS<, Gimatic, and 80/20 profiles, use #972 M5x12 low head screws, #865 lock washers, and appropriate slotted nuts. Fasteners on page 1077.

Use M5x16mm SHCS to attach to quick changer

Use Quick#s for easy online ordering.

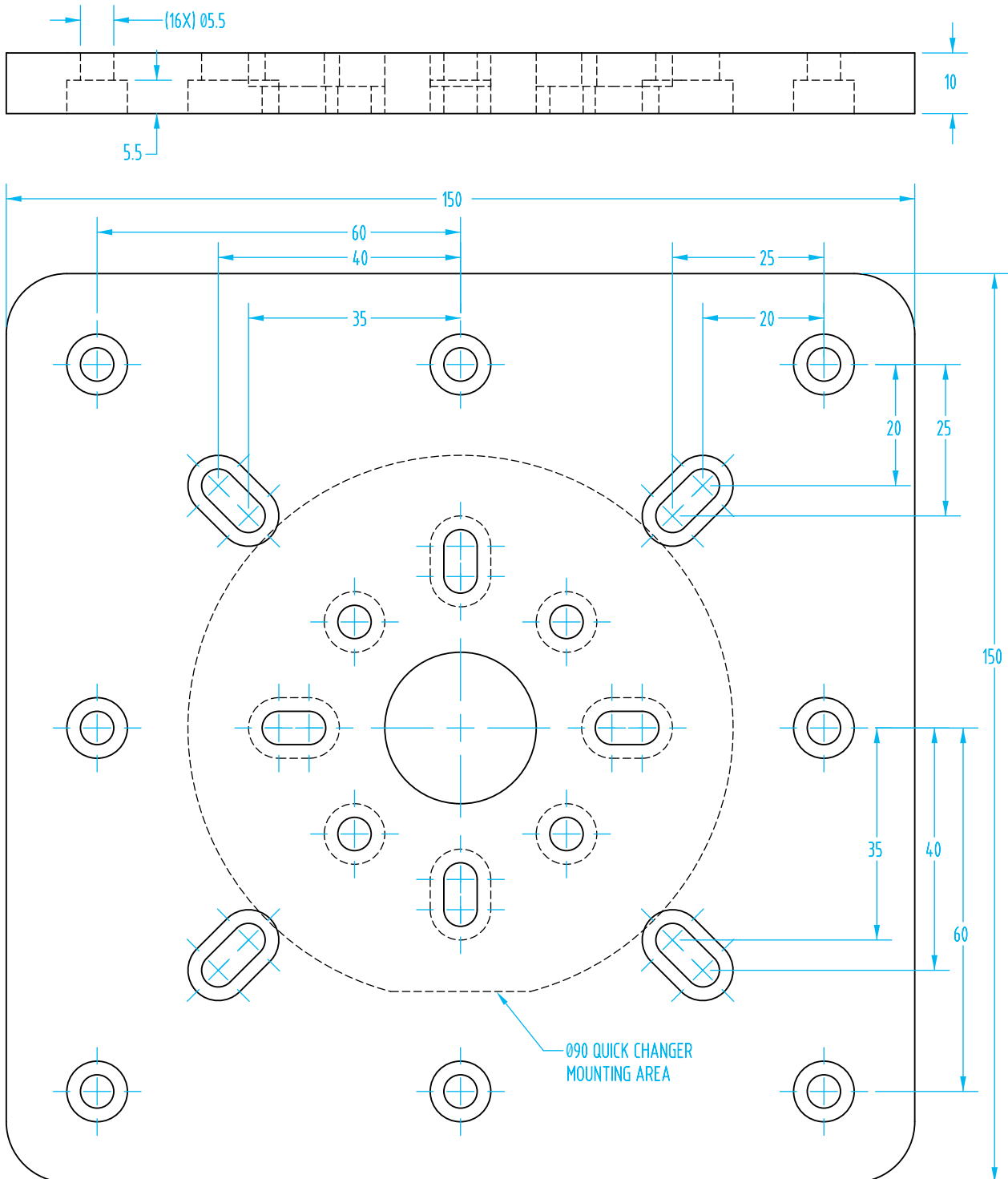

# Blank EOAT Mounting Plate for Standard Size (90mm) Quick Changers

(Dimensioned drawing shown full scale)

## Basic Blank Mounting Plate for Custom Mount

This anodized aluminum plate can be used as a manual EOAT mounting plate to adapt profiles as shown on page 42. It is scored with a center line making it easy to locate holes for mounting to your robot tooling plate. There is plenty of space on this plate to drill or tap holes as necessary. Pre-drilled and counter-bored holes simplify mounting to profile.

Standard Size (90mm) EOAT Mounting Plate

Quick#	Part#	Wt.	Price	Description
544	GSC-GMB-150	582g	\$42.80	For >ASS<, Gimatic and 80/20 profiles, use #972 M5x12 low-head screws, #865 lock washers, and appropriate slotted nuts. Fasteners on page 1077.

