

# Non-Rotating Suspensions – VSNG

(Dimensioned drawings shown full scale)

- Body and rod made of anodized aluminum.
- Non-rotating rod with high-load capability.
- Clampable smooth body.
- FDA-H1 food-grade lubricant.



### New Design Changes!

New Bushing and shaft design provides more reliable compensation and a more robust vacuum connection.

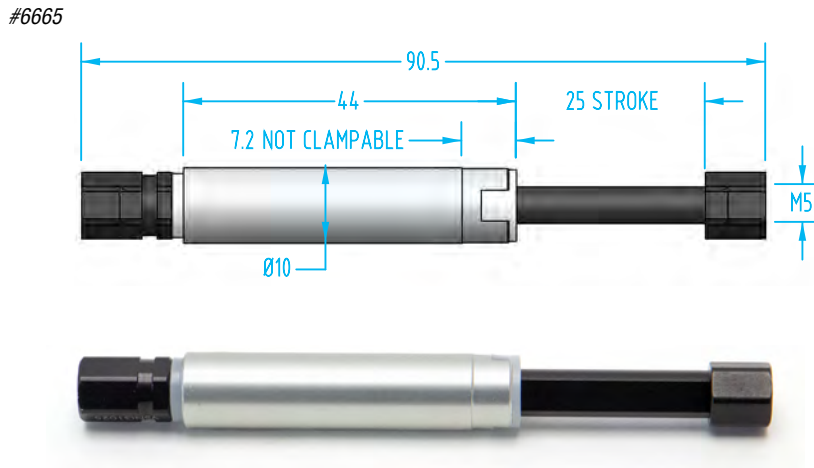
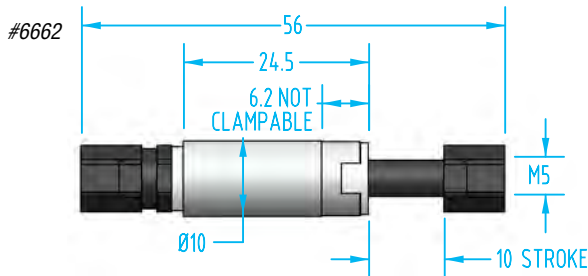

Quick#	Part#	Price	Air Port	ØD	Stroke	Wt.
6662	VSNG-1010	\$24.25	M5	10	10mm	7g
6665	VSNG-1025	\$26.90	M5	10	25mm	11g
6668	VSNG-1420	\$31.50	G1/8"	14	20mm	27g
6671	VSNG-1435	\$35.70	G1/8"	14	35mm	36g
6674	VSNG-2025-F18	\$39.90	G1/8"	20	25mm	63g
6677	VSNG-2050-F18	\$46.20	G1/8"	20	50mm	91g
7252	VSNG-2025-F14	\$39.90	G1/4"	20	25mm	60g
7253	VSNG-2050-F14	\$46.20	G1/4"	20	50mm	88g

Mounting Brackets  
Available on page 248



Use Quick#s for easy online ordering.

**Non-Rotating Suspensions – VSNG**

(Dimensioned drawings shown full scale)

#6668

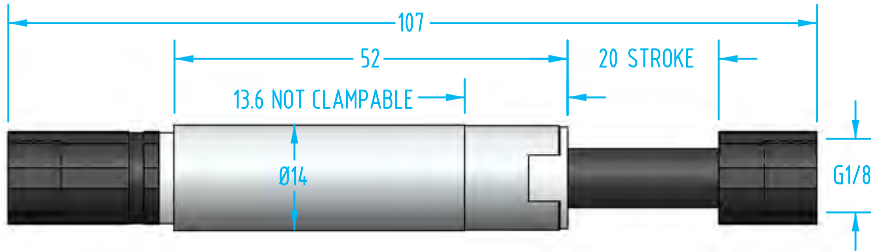

#6671

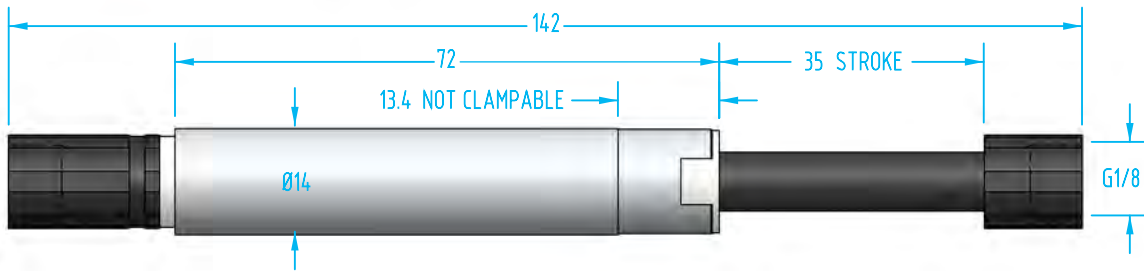

#6674

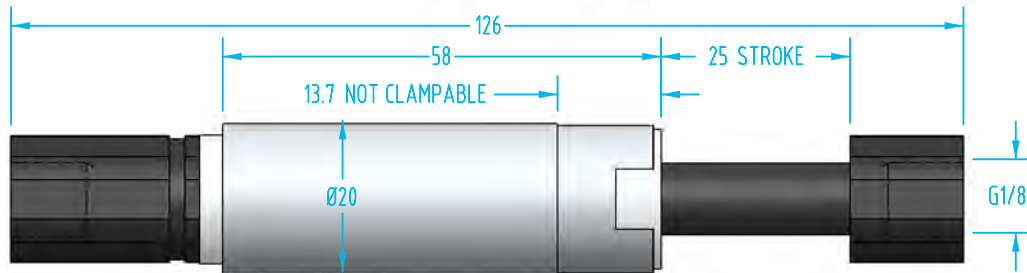

Note: Quick #7252 has the same dimensions except with G1/4" air ports

#6677

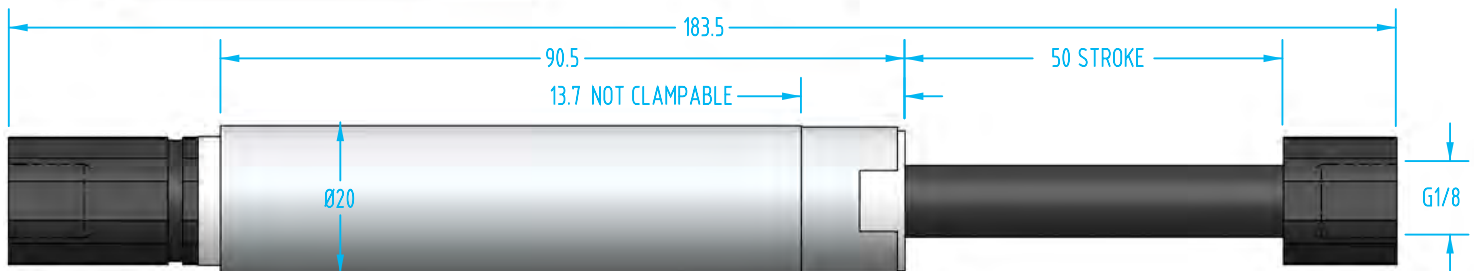

Note: Quick #7253 has the same dimensions except with G1/4" air ports