

Suspensions with Brake – Threaded Body

- Aluminum body and steel rod.
- Pneumatic brake available in two options:
Normally Open (NO) = Supply pressure to engage brake, and Normally closed (NC) = Supply pressure to unlock brake.
- Available in both rotating (VSRTF) and non-rotating (VSNTF) shafts.
- SS Sensors (for all models), SI Inductive Sensors (for NC models only) detects when the brake is engaged, not shaft position. See page 1007.

Pneumatic brake suspensions combine the compliance of a traditional suspension with the rigidity of a fixed location mount. They can be used in applications where height compensation is needed but then the suspension position must be maintained until the part is released. When locked, this prevents the suspension from exerting force which could affect part position or part integrity.

Also, by locking the suspension in place, this can reduce the occurrence of overcoming the spring force sometimes experienced in fast moving applications where part inertia is a factor.

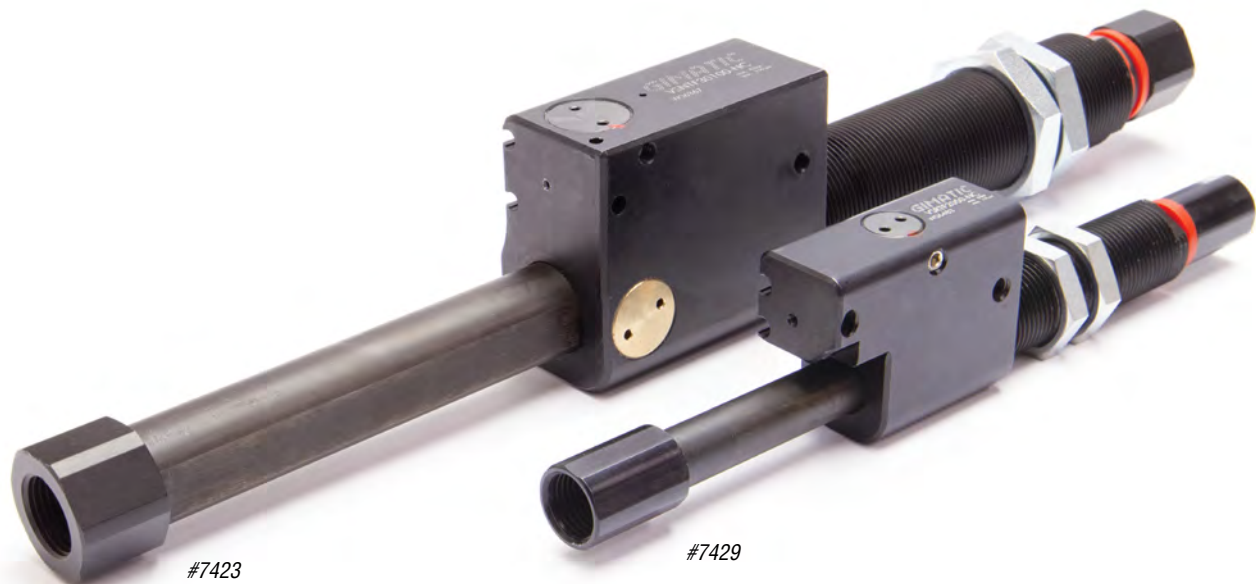

Quick#	Part#	Price	Style	Pass Through Air Port (K)	Break Air Port (P)	Mount	Stroke	Operating Pressure for Locking (P1)	Operating Pressure for Unlocking (P2)	Braking Force	Wt.
7421	VSNTF2050-NC	\$444.00	Non Rotating Shaft	G1/4"	M5	M20x1.5	50mm	-	58-116psi	45lbf	270g
7422	VSNTF2050-NO	\$444.00		58-101psi	-	1.24lbf x P1 – 34lbf	270g				
7423	VSNTF30100-NC	\$522.00		G3/8"	M5	M30x1.5	100mm	-	58-116psi	112lbf	890g
7424	VSNTF30100-NO	\$522.00		43-116 psi	-	3.1lbf x P1 – 90lbf	890g				
7429	VSRTF2050-NC	\$395.00	Rotating Shaft	G1/4"	M5	M20x1.5	50mm	-	58-116psi	45lbf	270g
7430	VSRTF2050-NO	\$395.00		58-101psi	-	1.24lbf x P1 – 34lbf	270g				
7431	VSRTF30100-NC	\$489.00		G3/8"	M5	M30x1.5	100mm	-	58-116psi	112lbf	890g
7432	VSRTF30100-NO	\$489.00		43-116 psi	-	3.1lbf x P1 – 90lbf	890g				

Suspensions with Brake – Threaded Body

(Dimensioned drawings show full scale Size 20)

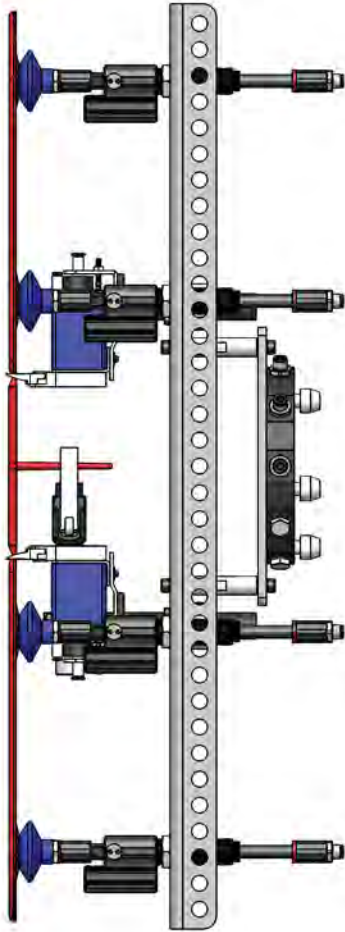

Pneumatic brake suspensions can absorb an ejection stroke and then be locked in place for degating as shown in the above application.

	Size 20 #7421 / 7422 #7429 / 7430	Size 30 #7423 / 7424 #7431 / 7432
A	201.5	324.5
B	M20x1.5	M30x1.5
C	24	35
D	43	57
E	22	32.2
F	26	28
G	62.4	113
H	55	65.5
I	31	40
J	10	13
K	G1/4"	G3/8"
L	50	100
M	23	18
N	16	24
P	M5	M5
R	16.5	18
S	7	8
T	24	36

