

Modular Vacuum Kit – Gimatic Kit-V

KIT-V for UR and Fanuc CRX and Techman Robots is a modular and durable vacuum end effector. A lightweight, extruded aluminum frame offers versatility so it can be used for different tasks with minimal setup time.

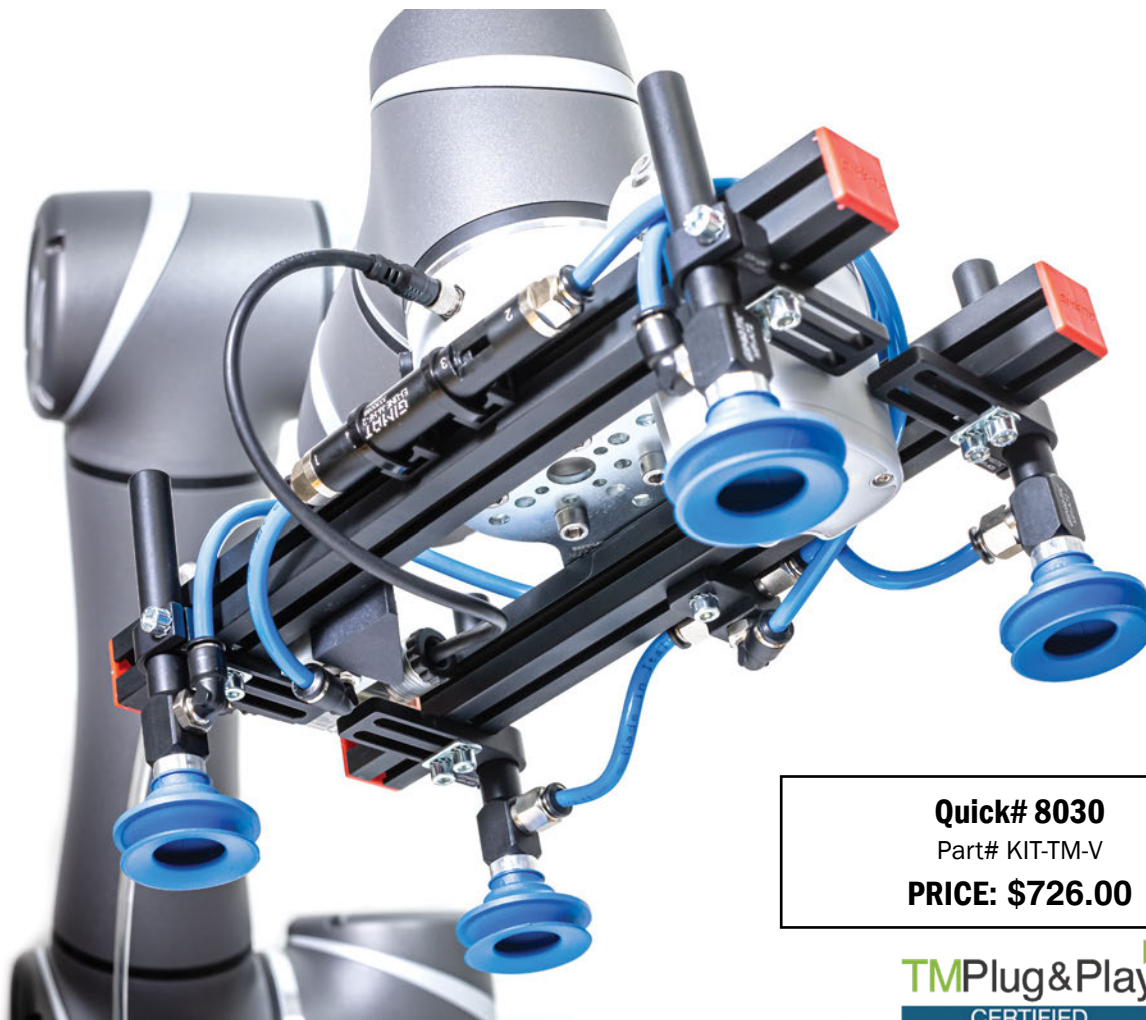

Quick# 8030
Part# KIT-TM-V
PRICE: \$726.00

TMPlug&Play
CERTIFIED

Gimatic by EMI KIT-UR-V & KIT-TM-V

End Of Arm Tool (EOAT) for vacuum based pick & place operations. The included pneumatic actuator allows for a direct connection to the robot wrist.

The KIT-TM-V is designed for Techman Robot cobots (TM5, TM12 and TM14 series). This kit is completely compatible with Gimatic EQC20-TM (Quick#8155) and it can be used in combination with any collaborative robot that provides a limited power supply capability at the wrist.

Mount the system with the included mechanical flange to the wrist of the robot and connect the main valve inlet to the pneumatic power source. The system can be electrically connected directly to the wrist of the robot. The system can be operated via digital output from the tool interface of the UR robot.

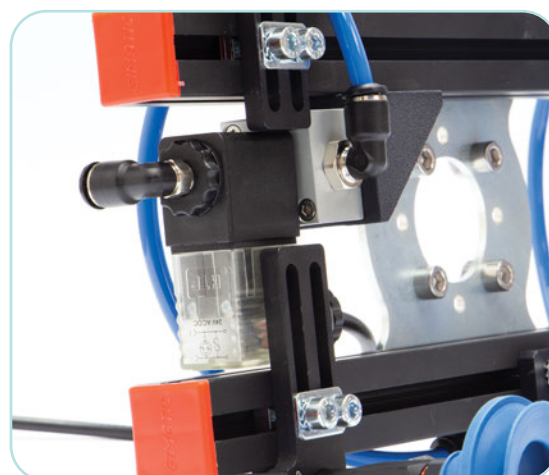

Complete with embedded vacuum generator and solenoid valve.

Modular Vacuum Kit – Gimatic Kit-V

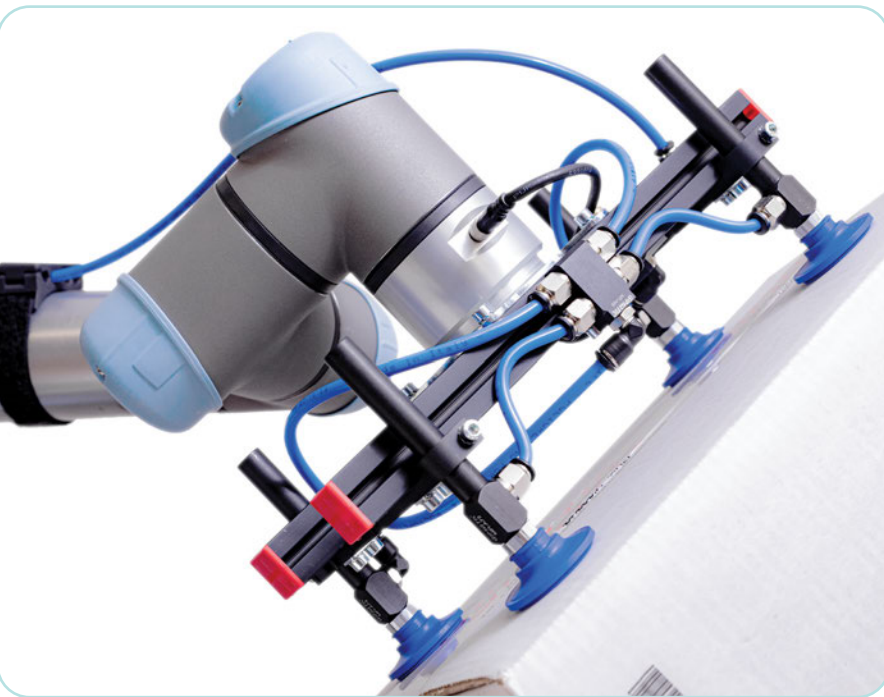

- **Delivered fully assembled, and easy to adjust.**
- KIT-UR-V: Compatible UR and Fanuc CRX.
- KIT-TM-V: Compatible with TM5, TM12 and TM14.
- Directly connects to the wrist of the robot.
- Plug & play solution.
- Embedded vacuum generator and solenoid valve.
- Delivery with standard HNBR vacuum cups. Contact EMI for different vacuum cups.
- Weight: 1.3 kg.

Quick# 8011
 Part# KIT-UR-V
PRICE: \$726.00



- CU
- QC
- VG
- VC
- VA
- SG
- GR
- MT
- AC
- CS
- CC

Dimensions (mm):

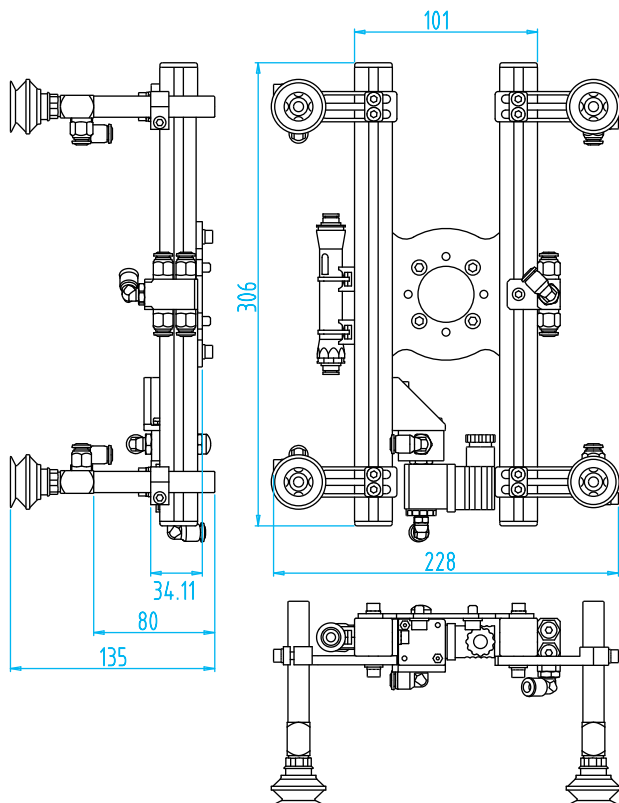

Adjustments (mm):

