

Three-Jaw Gripper for Cobots – OnRobot 3FG15



The 3FG15 is ideal for gripping a wide range of cylindrical objects in machine-tending applications such as CNC lathe machines.

The gripper's design automatically centers workpieces, resulting in fast deployment with a strong, stable grip and precise placement.

Quick# 8203
Part# OR-103666
PRICE: \$5,768.00

OnRobot pricing effective 05/01/24 and subject to change.

Try It Risk Free!

*Contact us for details



- 3Grip indications (part confirmation).
- Custom fingers available from EMI.
- Automatic tool center point (TCP) calculation, depth compensation, and payload calculation for UR.
- Integrated software.
- IP67 rating for harsh environments and ISO Class 5 certification for cleanroom use.

Technical Specs	
Total OD stroke (w/ stock fingers)	4–152mm
Total ID stroke (w/ stock fingers)	35–176mm
Payload with stock fingers (force fit)	22.04 lb (10 kg)
Payload with custom fingers (form fit)	33.06 lb (15 kg)
Finger position resolution	±0.1mm
Repetition accuracy	± 0.1mm–0.2mm
Gripping force (adjustable)*	10 – 240 N (2.25 – 54 lbf)
Gripping force deviation	+/- 5%
Gripping speed**	125mm
Gripping time***	500ms
Storage temperature	32° – 140°F
Weight	1500g (2.5 lb)
Power supply	20V – 25V
Max. Current consumption****	1500mA
Operating temperature	41° – 122°F

* The required current is 2000 mA, less current will result in less gripping force.
 ** Relatively from the gripping object (both arms).
 *** At 4 mm stroke and 80 N. The typical value is 300 ms at 40 mm and 80 N.
 **** Automatically adapts to the current requirements when UR CB3 tool connector is used (600mA).

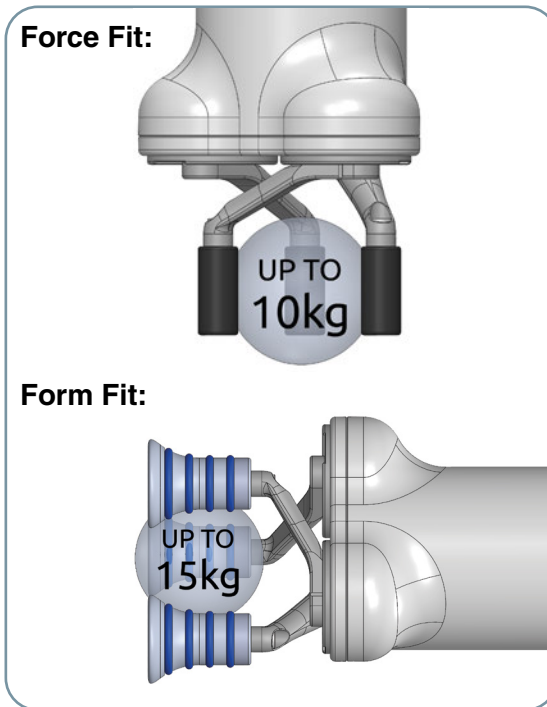



Three-Jaw Gripper for Cobots – OnRobot 3FG15

(Dimensioned drawings reduced to fit)

Ships Same Day!

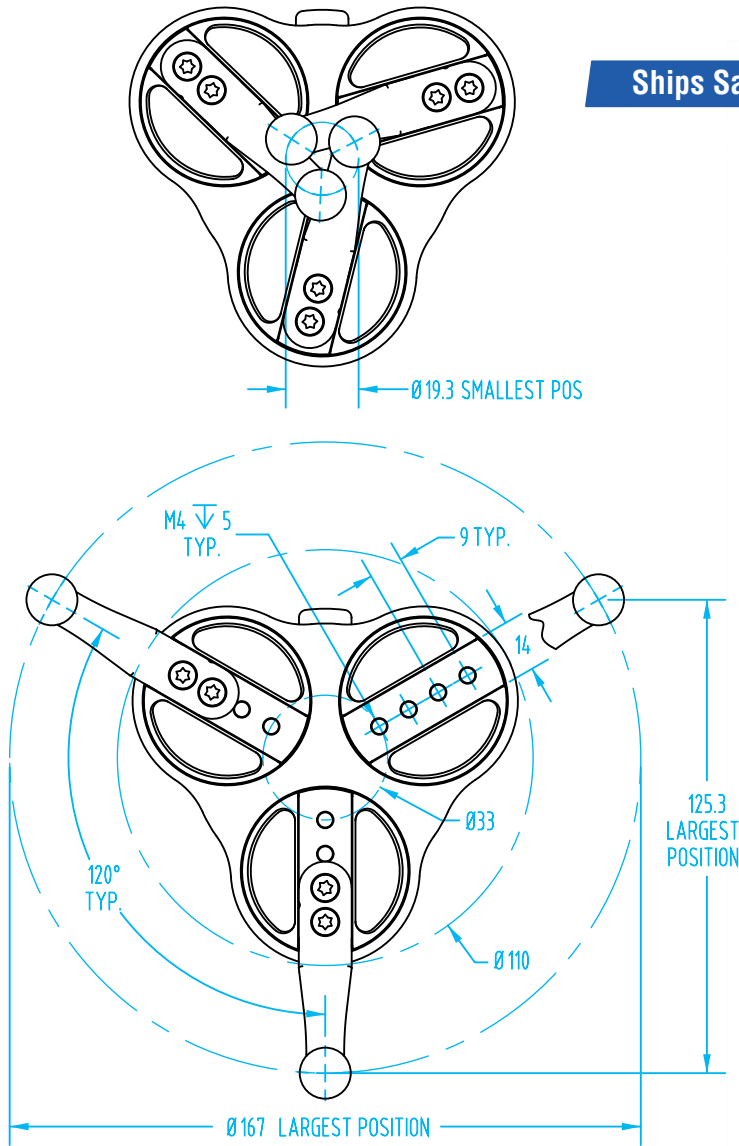

3FG15 Replacement fingers and bumpers



Quick#	Part#	Description	Price
8290	OR-104160	Ø10mm Steel fingers (3pc)	\$86.67
8291	OR-104162	Rubber bumpers for Ø10mm fingers (3pc)	\$86.67
8292	OR-104241	Ø13mm Steel fingers (3pc)	\$86.67
8293	OR-104240	Rubber bumpers for Ø13mm fingers (3pc)	\$86.67
8278	OR-106963	X-Shape Steel fingers (3pc)	\$233.33
8294	OR-104161	Steel finger base for fingers (3pc)	\$160.00