

Manual Quick Changer – SCHUNK CMS



Available from EMI, this manual size 50 CMS quick changer is ideally suited for use in both production and assembly environments. The integrated air ports coupled with a wide variety of electrical connectors makes this product by SCHUNK a great fit for many application types.

Contact EMI to explore the variety of tool changer sizes and electrical accessories available for this robust and user friendly product.

- **Suggested payload: 24.2 lbs (11kg)**
- Integrated locking lever provides an extra level of safety to prevent accidental uncoupling.
- Includes (6) integrated air ports for pneumatic and vacuum supply.
- Robot side QC adapts directly to robot tool flange with ISO 9409-1-50-4-M6 mount interface.
- Tool side QC mirrors the ISO 9409-1-50-4-M6 hole pattern.
- Locked position sensing available, contact EMI for more information.
- Optional electrical connectors available with M8 8-pin connector. 15-pin D-sub connector available upon request.

Quick#	Part#	Description	Wt	Price
8352	CMS-050-K	Robot-Side	292g	\$1,010.00
8353	CMS 050-A	EOAT-Side (Tool-Side)	164g	\$578.00
8361	SWO-EM8-011-K	Robot-Side Electrical Connector	30g	\$373.00
8362	SWO-EM8-011-A	EOAT-Side Electrical Connector	34g	\$369.00

Dimensional drawings and other technical specifications for electrical connectors available at EMICorp.com

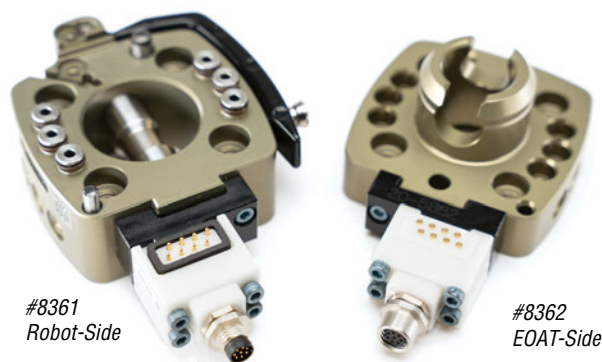

Manual Quick Changer – SCHUNK CMS

(Dimensioned drawings reduced to fit)

Safety loads

Check the table for the maximum loads allowed. Excessive forces or torques can damage the system, cause operation problems and endanger the safety of the operator.

	Max.
Mx	55.3 ft-lbs
Mz	99.5 ft-lbs
Fz	202.3 lbs
My	55.3 ft-lbs

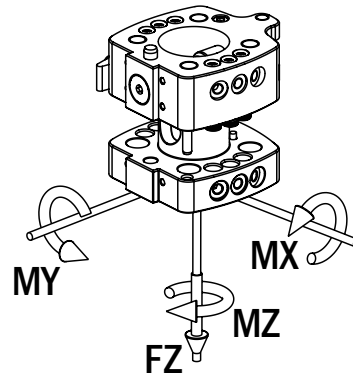

Robot-Side:

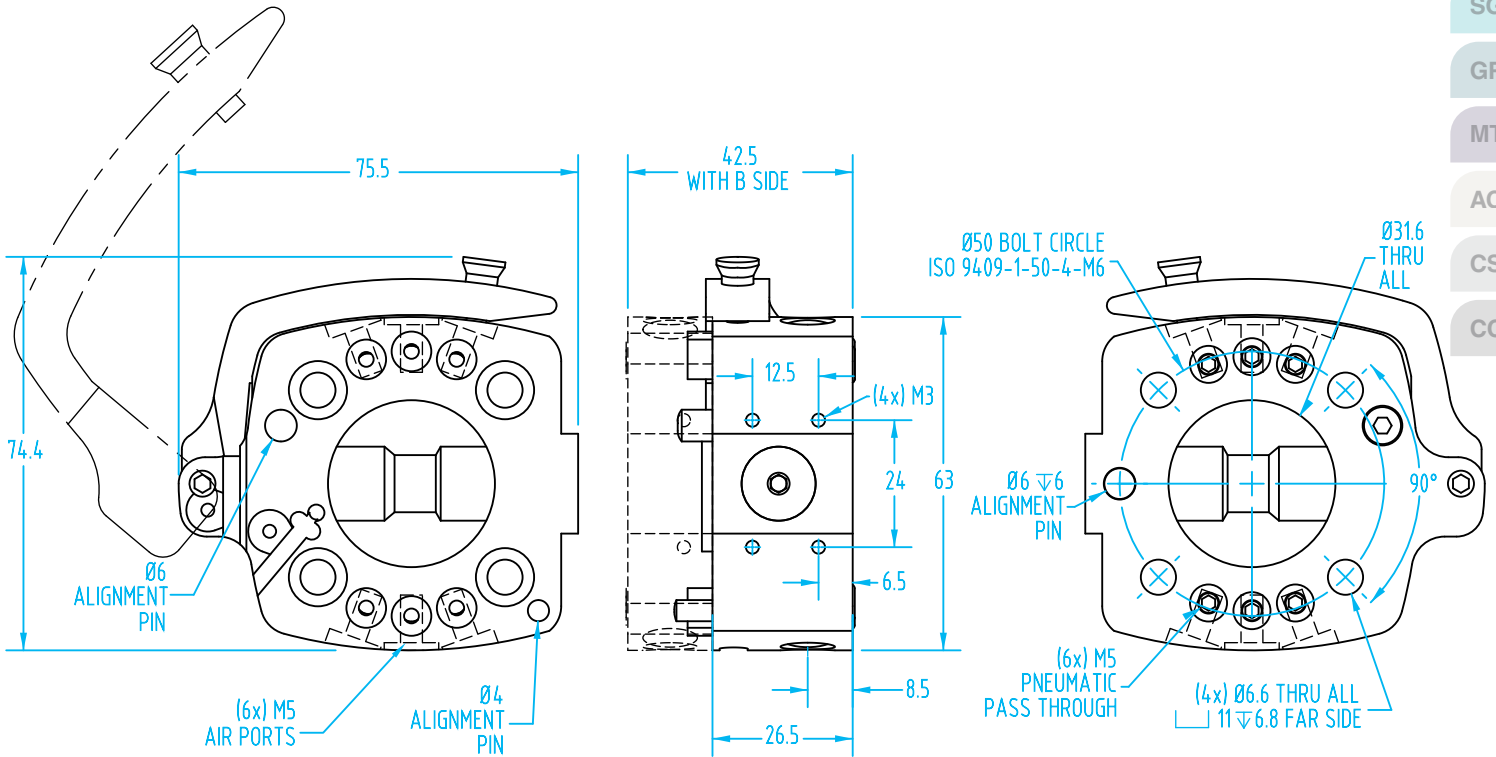

EOAT-Side:

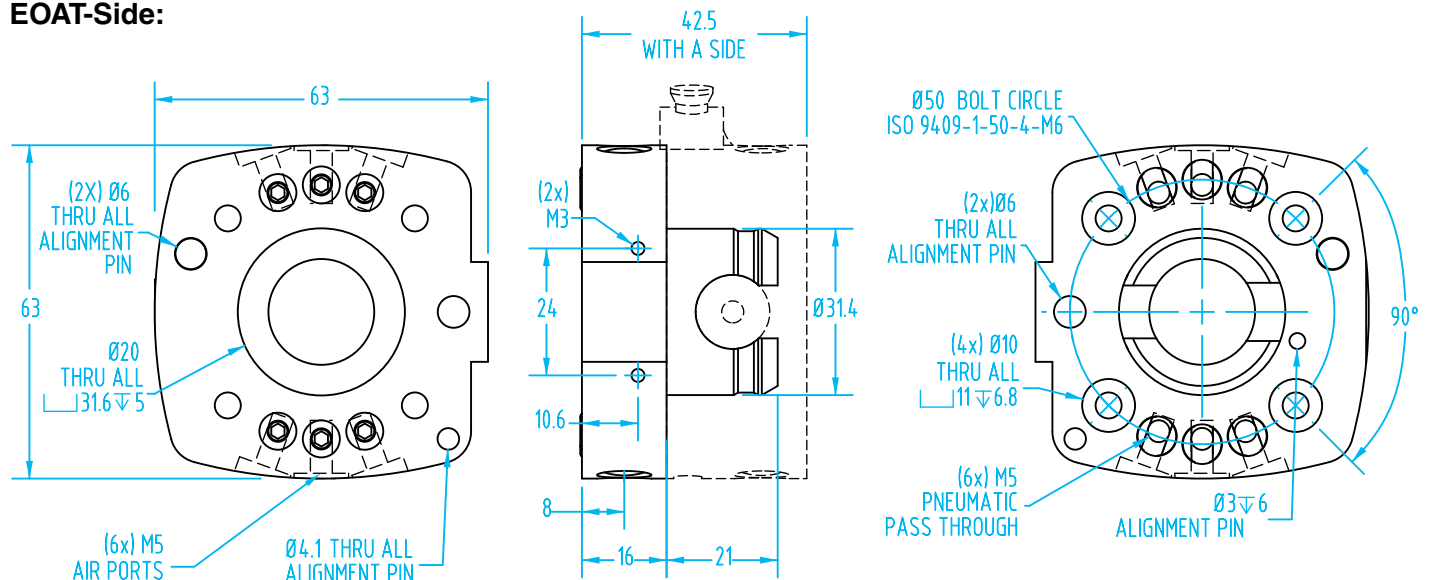

- CU
- QC
- VG
- VC
- VA
- SG
- GR
- MT
- AC
- CS
- CC