

Suction cups / FDA-compliant silicone

VG.FP30F multi-bellows suction cups in FDA-compliant silicone

- The silicone is FDA-compliant and therefore suitable for handling unpackaged food
- Suitable for level compensation
- High vertical movement, useful for separating thin parts
- It can be equipped with a perforated disc to increase stability and to allow the handling of thin films

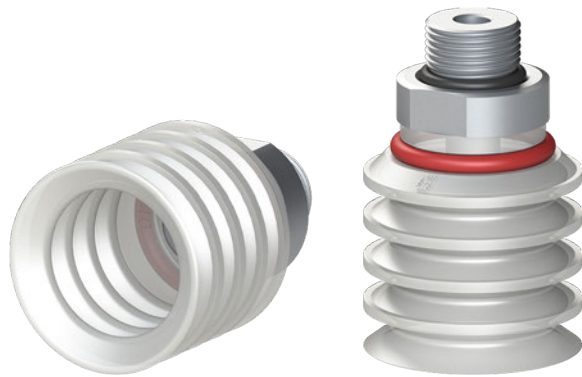

Application example



Technical data

Material	Lifting force [N] perpendicular to the surface, at various vacuum levels			Lifting force [N] parallel to the surface, at various vacuum levels			Volume [cm ³]	Min curve radius [mm]	Max vertical movement [mm]	Suction cup weight [g]
	-20 kPa	-60 kPa	-90 kPa	-20 kPa	-60 kPa	-90 kPa				
SIL FDA 50	6.5	10.3	–	–	–	–	10	8	20	7

Technical features

Material	Color	Hardness	Temperature range
Silicone, FDA SIL	Transparent	50 Shore	-94 - +392 °F

Identification codes			
Drawing	Alphanumeric code	Suction cups with fitting	Order code
A	VG.FP30F.50.G18F	VG.FP30 suction cup, FDA-compliant silicone, 50 Shore, G1/8" female	2322075
B	VG.FP30F.50.G18M	VG.FP30 suction cup, FDA-compliant silicone, 50 Shore, G1/8" male	2322077
C	VG.FP30F.50.G14M	VG.FP30 suction cup, FDA-compliant silicone, 50 Shore, G1/4" male	2322078
D	VG.FP30F.50.G38M	VG.FP30 suction cup, FDA-compliant silicone, 50 Shore, G3/8" male	2322079

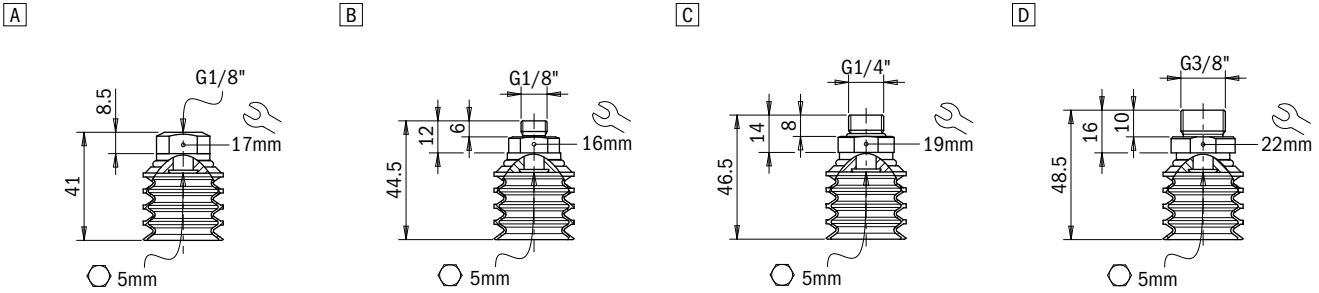

Identification codes			
Drawing	Alphanumeric code	Suction cups	Order code
A	VG.FP30F.50	VG.FP30 suction cup, FDA-compliant silicone, 50 Shore	2322076

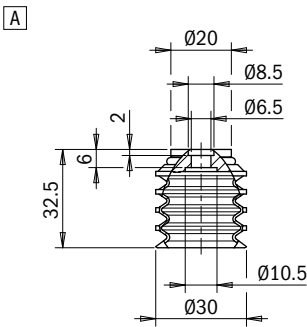

Identification codes			
Drawing	Alphanumeric code	Fittings	Order code
A	FT.G18F.18	G1/8" female fitting	1800019
B	FT.G18M.18	G1/8" male fitting	1800018
C	FT.G14M.18	G1/4" male fitting	1800014
D	FT.G38M.18	G3/8" male fitting	1800038

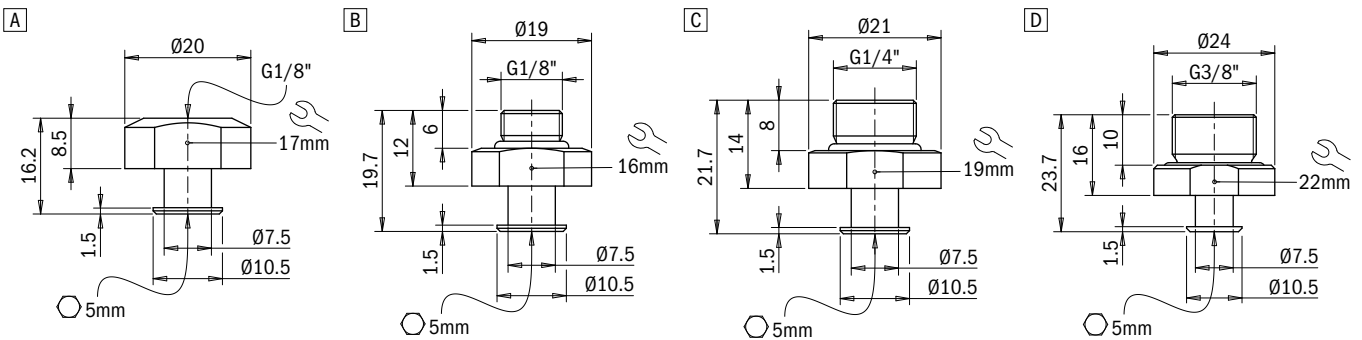

Identification codes		
Alphanumeric code	Disc	Order code
AC.DF30	Perforated disc for thin films, diameter 30 mm	2321781