

2-jaw self-centering radial pneumatic gripper (series PS-P)

- Double acting radial motion.
- The gripping force is totally available on both directions from 0° to 90°.
- Lightweight, being totally in light alloy.
- Flat profile.
- Well protected against dusty environment.
- As more than two sensors can be mounted, versatile operating is possible.
- FDA-H1 food-grade grease.



PS-0016-P



PS-0025-P



PS-0045-P

	PS-0016-P	PS-0025-P	PS-0045-P
Medium	Compressed air in compliance with ISO 8573-1:2010 [7:4:4]		
Operating pressure range	2 ÷ 8 bar		
Operating temperature range	5 ÷ 60 °C.		
Stroke	2 x 90°		
Gripping torque at 6 bar on each jaw	100 Ncm	280 Ncm	1800 Ncm
Total gripping torque at 6 bar	200 Ncm	560 Ncm	3600 Ncm
Maximum working frequency	2 Hz	2 Hz	1 Hz
Cycle air consumption	16 cm ³	57 cm ³	382 cm ³
Closing time without load	0.06 s	0.09 s	0.15 s
Repetition accuracy	0.1°	0.1°	0.1°
Weight	320 g	650 g	2700 g

Dimensions (mm)

PS-0016-P

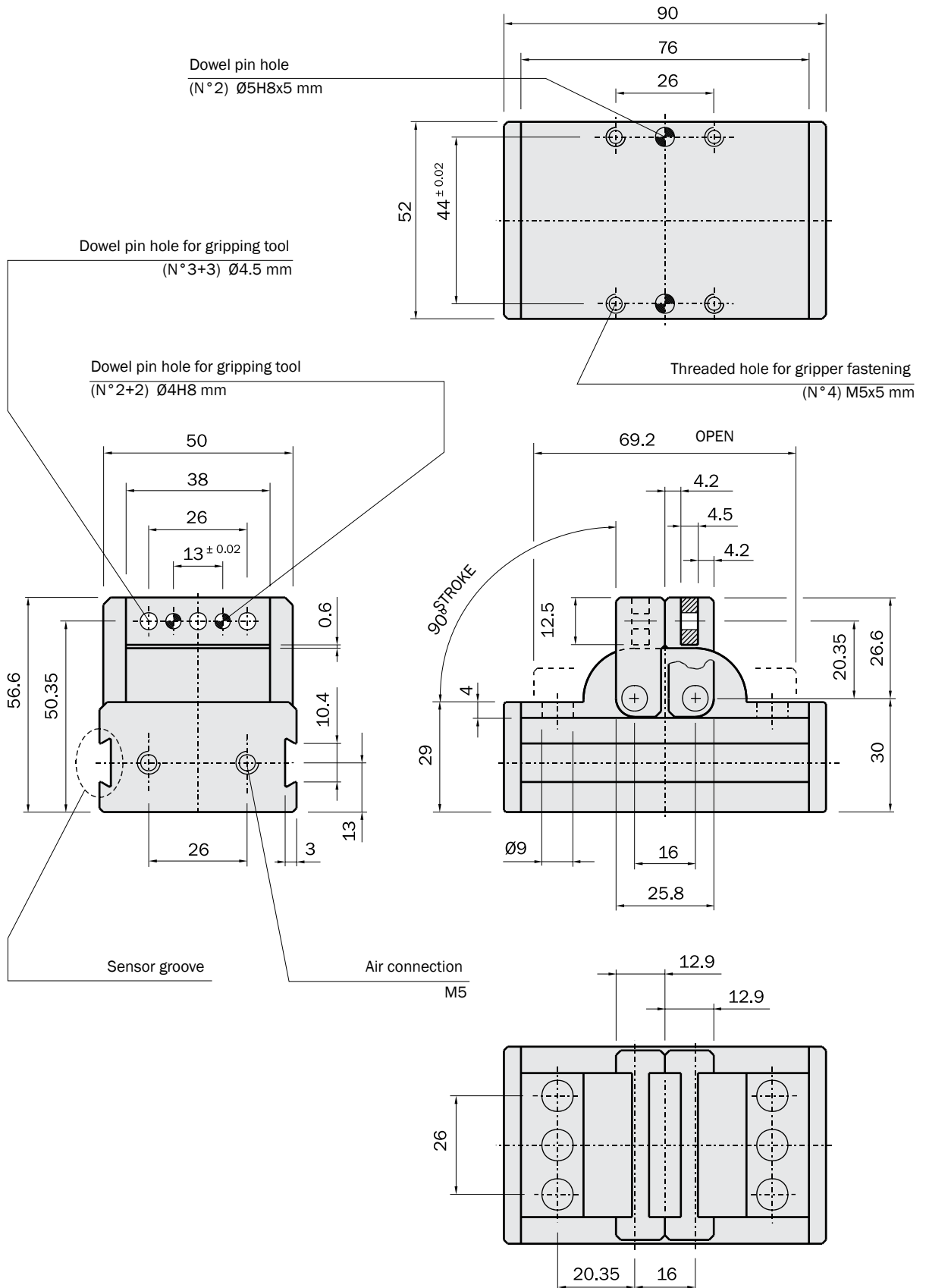



Rotary Units

Quick Changer

Profiles and Brackets

Grippers

Linear Actuators

Suspensions

Nippers

Robot Kit

Options

Sensors

