

# ACRC Clean Room Conveyor - Exploded View

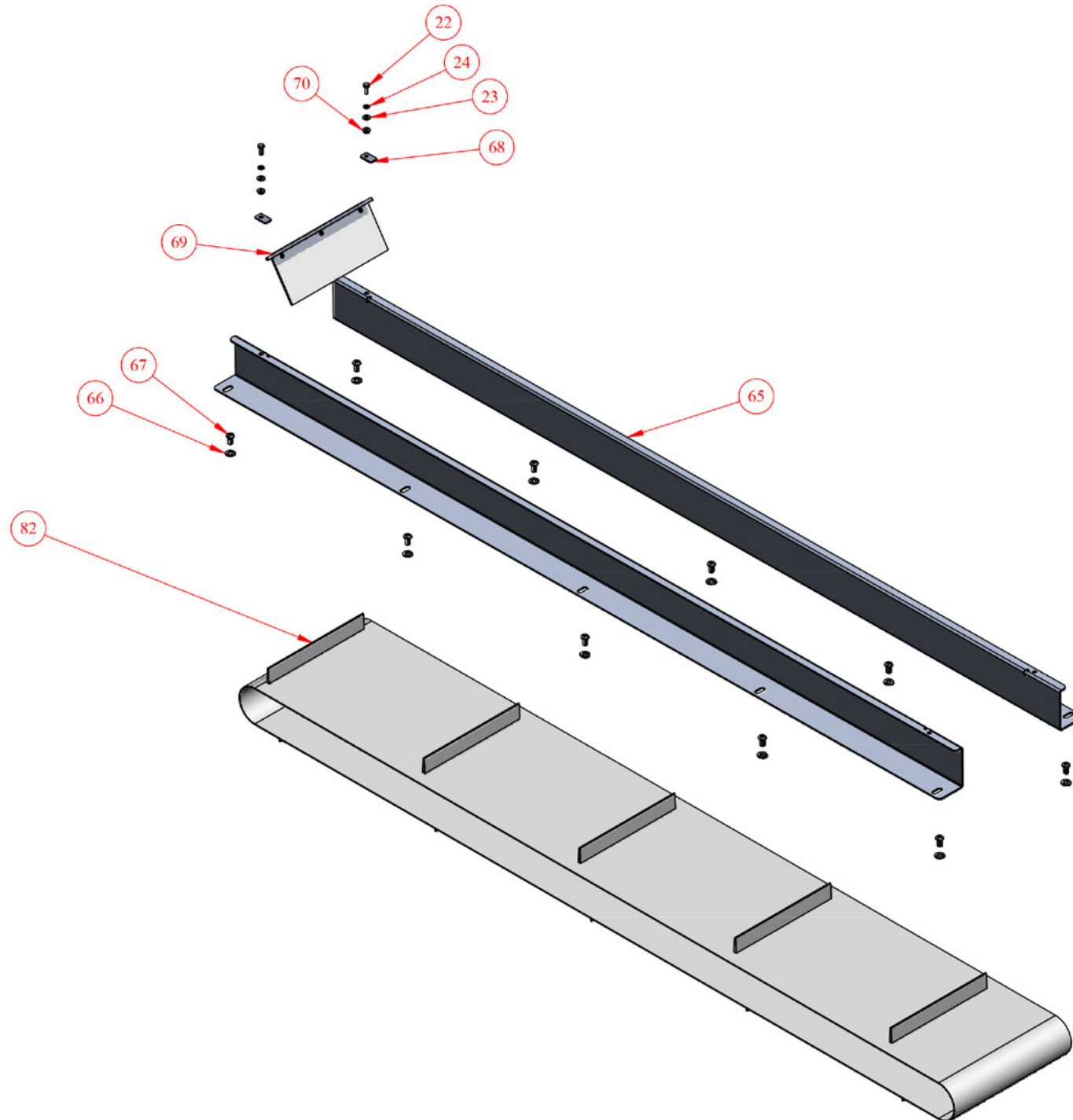

# ACRC Clean Room Conveyor - Exploded View

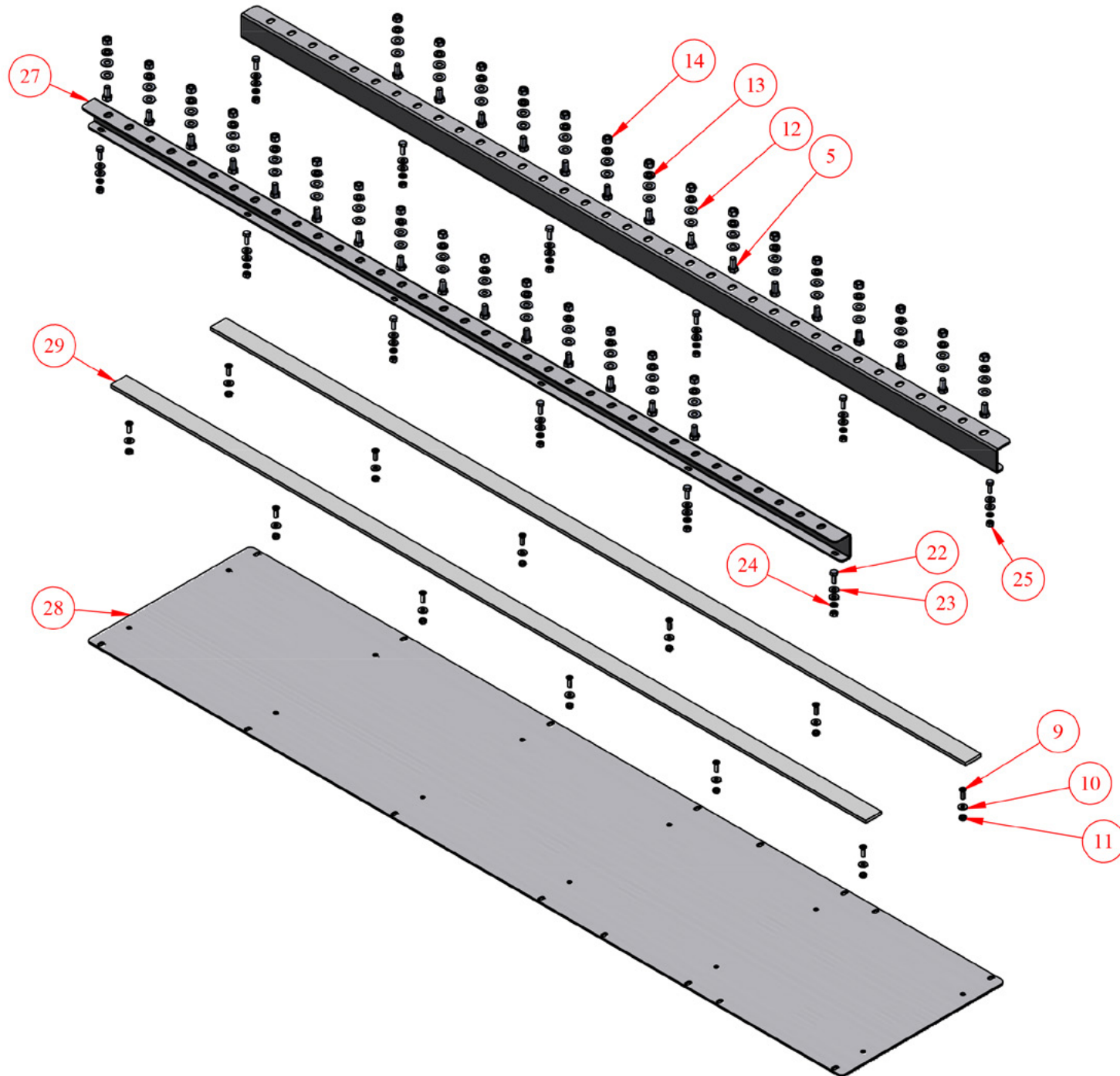

# ACRC Clean Room Conveyor - Exploded View

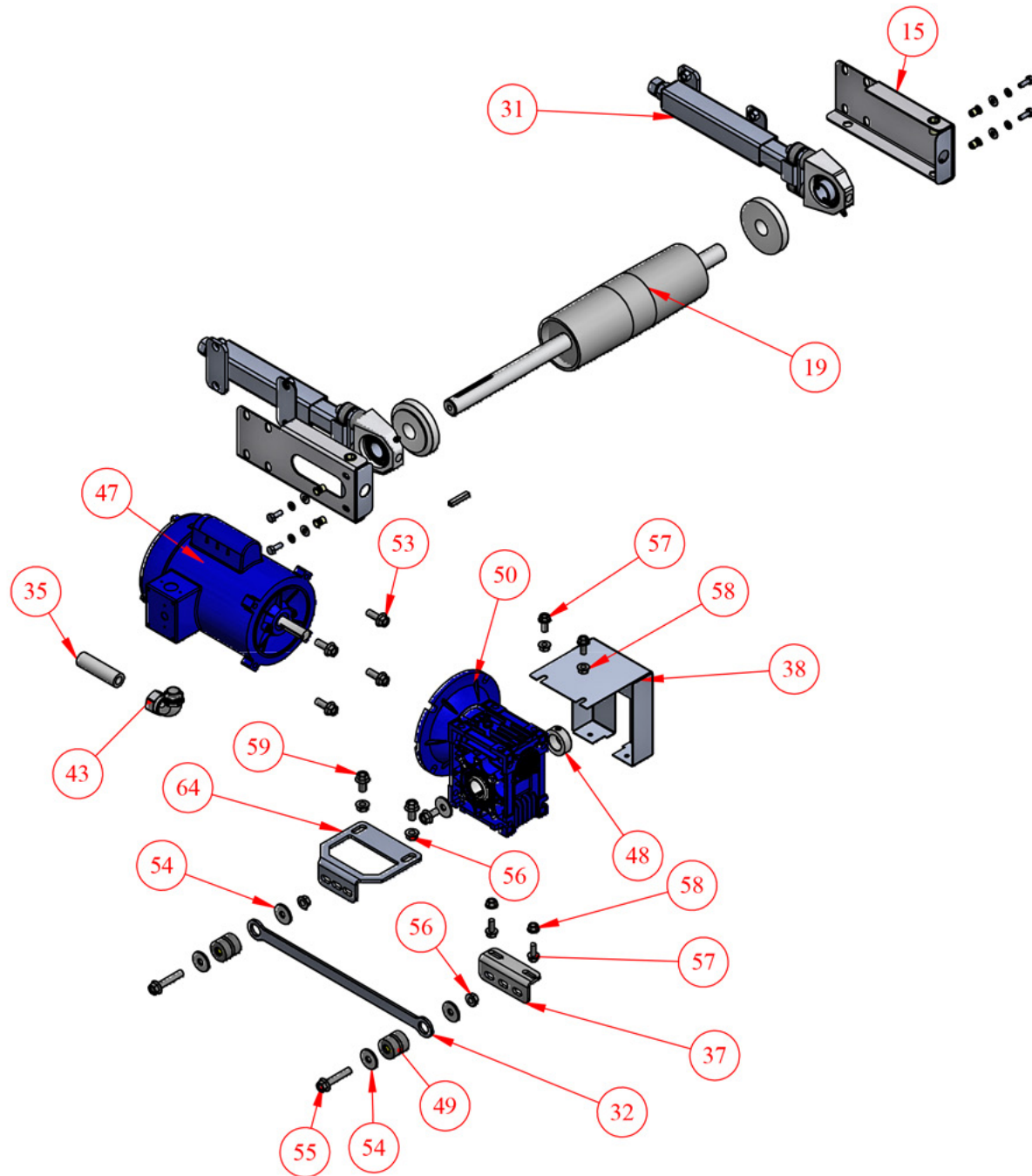

# ACRC Clean Room Conveyor - Exploded View

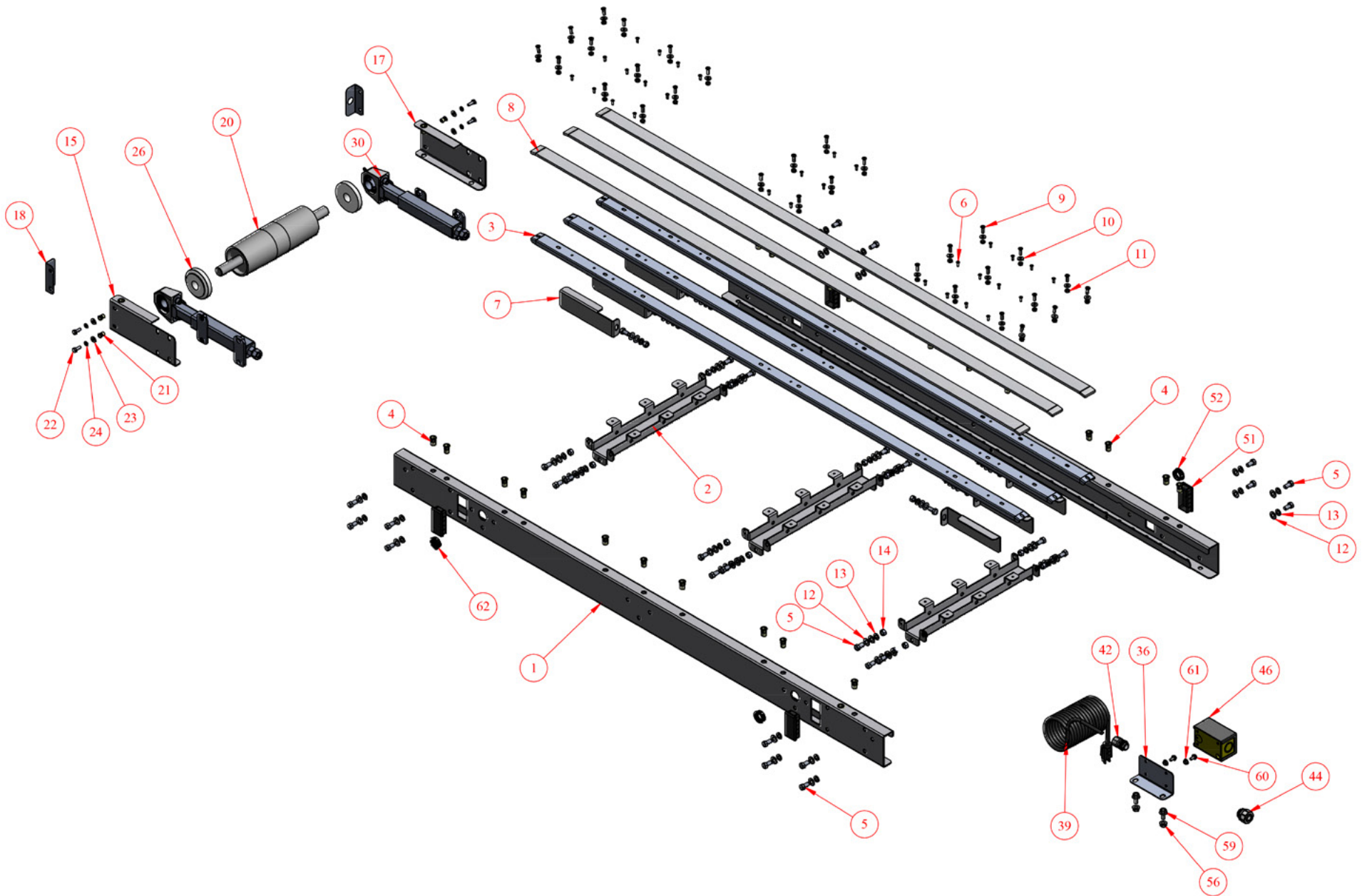

## ACRC Clean Room Conveyor - Exploded View

NO.	QTY.	PART NO.	DESCRIPTION
1	2	4M-44-41-L	AD FRAME SIDE
2	3	4M-41-21-W	FRAME CROSSBRACE
3	3	4M-45-39-L	SST SLIDE TRAY
4	26	CP-2867	HEX NUT INSERT 3/8-16 GRIP RANGE .150-.312 #AH-S- 4-616-312
5	70	CP-2155	HEX HEAD SCREW .375-16 x .750 SST
6	30	CP-2052	POP RIVET 3/16 RIVET, CTRSK HEAD,
7	6	4M-29-1-CR	SLIDE TRAY END SUPPORT
8	3	2L-31-8-L	UHMW SPACER
9	42	CP-282	SLOTTED FLAT HEAD SCREW .250-20 x .750
10	42	CP-1997	FLAT WASHER .250 SAE 80/20
11	42	CP-600	1/4-20 PLATED ELASTIC LOCK NUT
12	124	CP-768	FLAT WASHER .375 SST
13	110	CP-186	LOCK WASHER .375 SPLIT RING SST
14	94	CP-179	HEX NUT .375-16 SST
15	2	4M-08-1-(L/R)	PULLEY GUARD
16	1	4M-08-2-(L/R)	PULLEY GUARD
17	1	4M-08-1-(L/R)	PULLEY GUARD
18	4	2M-67-1-S	SST BEARING COVER
19	1	4M-210-9-W	DRIVE PULLEY WELD ASSY
20	1	4M-224-4-W	TAIL PULLEY WELD ASSY
21	8	CP-2132	1/4 - 20 AVIBANK NUTSERT
22	22	CP-188	HEX HEAD SCREW .250-20 x .750 SST
23	34	CP-182	FLAT WASHER .250 SAE SST
24	22	CP-185	LOCK WASHER .250 SPLIT RING SST
25	12	CP-180	HEX NUT .250-20 SST
26	4	4M-15-2	V-GUIDE PROTECTION IDLER
27	2	4M-44-19-L	2" BOTTOM BELT GUARD SIDE
28	1	4M-45-16-L-W-U	BOTTOM BELT TRAY (UHMW LINED)

Part numbers listed in this document are for reference only. When buying replacement parts please provide your conveyor model & serial number to ensure the correct part.

## ACRC Clean Room Conveyor - Exploded View

NO.	QTY.	PART NO.	DESCRIPTION
29	2	4M-29-34-L	UHMW WEAR STRIP
30	2	2M-232-3-S	TAKE-UP ASSY
31	2	2M-232-4-S	TAKE-UP ASSY
32	1	2M-38-1-S	SST REACTION ROD
33	1	4E-269-1	BLACK WIRE ASSY FOR STD DRIVE PAK
34	1	4E-269-2	GREEN WIRE ASSY FOR STD DRIVE PAK
35	1	4E-62-1	CONDUIT FOR STD DRV PAK
36	1	2M-14-3-S	FG-5 SWITCH MOUNTING BRACKET
37	1	2M-14-28-1-S	SST REACTION ROD BRACKET
38	1	2M-08-12-S	SST 050 MOTOVARIO GEARBOX OUTPUT SHAFT GUARD
39	1	2E-263-1	15' POWER CORD
40	1	EL-533	SQ.D. HEATER A9.85
41	3	EL-455	WIRE NUT "Y" TYPE
42	1	EL-358	APPLETON CORD GRIP CONNECTOR #CG-3150
43	1	EL-353	90 DEG .500 INCH CONDUIT FITTING (REF RACO)
44	1	EL-354	.500 INCH STRAIGHT CONNECTOR
45	3	EL-301	RING TERMINAL 14-16 AWG, #8 (STUD)
46	1	EL-168	SWITCH - FG5 SQ. D.
47	1	EL-116B	LINCOLN LM24598 1/3 HP 115/230/60/1
48	1	CP-1201	LOCKING COLLAR 1.000IDx1.625ODx.625TH
49	2	CP-3178	UNIVERSAL MOUNT (NARROW) #60166-4
50	1	CP-3290	MOTOVARIO GEAR REDUCER #NMRV050-40-56C
51	4	CP-1581	1 1/2 x 3" BLACK PLASTIC CAP
52	2	EL-394	HEYCO SNAP BUSHING #2182
53	4	CP-2939	HEX SERRATED FLANGE SCREW 0.375-16x1.000" ZINC PLATED
54	5	CP-671	FLAT WASHER .407IDx1.250ODx.125TH

Part numbers listed in this document are for reference only. When buying replacement parts please provide your conveyor model & serial number to ensure the correct part.

## ACRC Clean Room Conveyor - Exploded View

NO.	QTY.	PART NO.	DESCRIPTION
55	2	CP-3049	HEX SERRATED FLANGE SCREW 0.375-16x2.000" ZINC PLATED
56	6	CP-2869	SERRATED FLANGE NUT 0.375-16 ZINC PLATED
57	4	CP-2941	HEX SERRATED FLANGE SCREW 0.313-18x0.750" ZINC PLATED
58	4	CP-3786	5/16 FLANGE HEX NUT
59	5	CP-2890	HEX SERRATED FLANGE SCREW 0.375-16x0.750" ZINC PLATED
60	2	CP-3067	HEX SERRATED FLANGE SCREW 0.250-20x0.500" ZINC PLATED
61	2	CP-3068	HEX FLANGE NUT 0.25-20
62	2	EL-395	HEYCO DOME PLUG #2733
63	1	CP-1003	1/4"SQ x 1.500 KEY
64	1	2M-14-29-3-S	SST REACTION ROD BRACKET
65	2	2M-33-X	4"-90° SST SIDE RAIL
66	10	CP-3342	FLAT WASHER .375
67	10	CP-3293	HEX SOCKET BUTTON HEAD SCREW .375-16 x .750
68	2	2E-01-10	FLAPPER CLIP
69	1	4S-249-1-W	SST LEXAN FLAPPER ASSY
70	2	CP-3482	SERRATED FLANGE NUT 0.25-20 18-8 SST.
71	4	2M-14-16-S	SST LEG MOUNTING BRACKET
72	4	4S-236-X	LEG WELD ASSY
73	2	4S-241-1-W-DV	LEG BRACE WELD ASSY
74	4	4S-14-41	BRACKET
75	4	4S-36-X	LEG EXTENSION
76	4	4S-41-45-L	SST KNEE BRACE
77	4	CP-284	HEX JAM NUT .500-13 SST
78	80	CP-183	FLAT WASHER .375 SST SAE
79	8	CP-176	HEX HEAD SCREW .375-16 x 2.000 SST
80	32	CP-175	HEX HEAD SCREW .375-16 x 1.000 SST
81	4	CP-1239	SWIVEL CASTER, 4"X1 3/8"
82	1	BELT	BELT FOR ACRC

Part numbers listed in this document are for reference only. When buying replacement parts please provide your conveyor model & serial number to ensure the correct part.