

# RMC Conveyor Drive Head Assembly - Exploded View

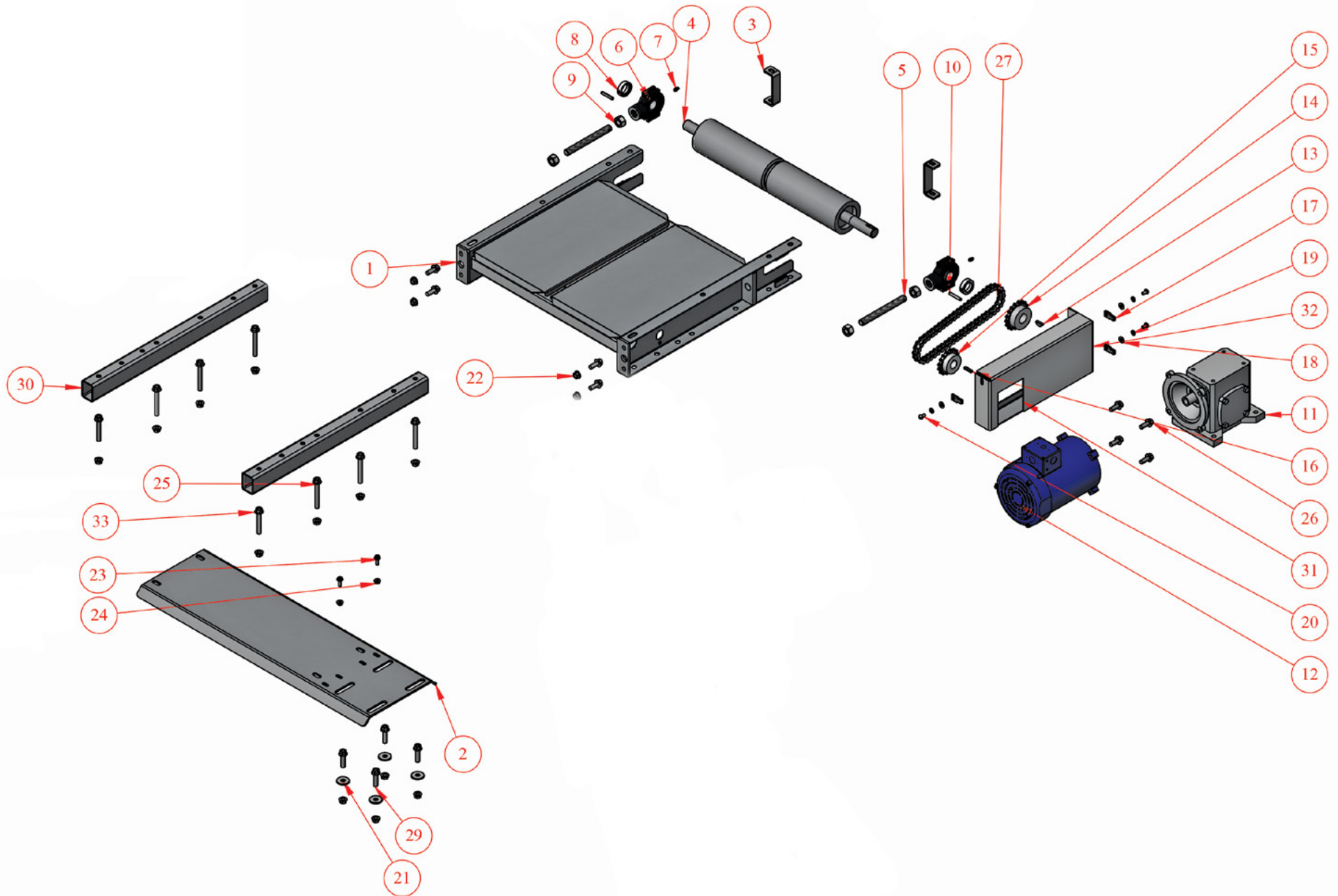

## RMC Conveyor Drive Head Assembly - Exploded View

NO.	QTY.	PART NO.	DESCRIPTION
1	1	4E-204-1-W	DR. HEAD WELD ASSEMBLY
2	1	4E-29-23-W	SUPPORT
3	2	4E-14-1	"C" CLIP
4	1	2E-210-3-W	DRIVE PULLEY
5	2	2E-32-5	THREADED ROD
6	2	CP-822	BEARING - RUPL - 16 X 1" BORE
7	2	CP-2778	.250-28 GREASE ZERK
8	2	CP-1209	LOCKING COLLAR .500IDx1.000ODx.4375TH
9	4	CP-505	HEX NUT .625-11
10	2	CP-1360	ROLL PIN .250 x 1.500
11	1	CP-1754	BOSTON GEAR #F718B-60T-B5-G1
12	1	EL-116B	LINCOLN LM24598 1/3 HP 115/230/60/1
13	1	CP-1005	1/4 X 7/8 WOODRUFF KEY
14	1	CP-1364	SPROCKET, 40B18 x 1"
15	1	CP-1295	SPROCKET 40B16 x .875
16	1	CP-1006	3/16"SQ x 1.000 KEY
17	3	CP-611	1/4-20 TINNERMAN NUT
18	3	CP-654	FLAT WASHER .250 SAE
19	3	CP-702	LOCK WASHER .250 SPLIT RING
20	3	CP-275	SLOTTED ROUND HEAD SCREW .250-20 x .500
21	4	CP-671	FLAT WASHER .407IDx1.250ODx.125TH
22	16	CP-2869	SERRATED FLANGE NUT 0.375-16 ZINC PLATED
23	2	CP-2942	HEX FLANGE SCREW 0.250-20x0.750
24	2	CP-3068	HEX FLANGE NUT 0.25-20
25	6	CP-3873	HEX SERRATED FLANGE SCREW 0.375-16x3.000" ZINC PLATED
26	8	CP-2939	HEX SERRATED FLANGE SCREW 0.375-16x1.000" ZINC PLATED
27	1	2E-40-4	ROLLER DRIVE CHAIN #40
28	1	CP-1297	#40 CONNECTOR LINK
29	4	CP-3751	HEX SERRATED FLANGE SCREW 0.375-16x1.500" ZINC PLATED
30	2	4E-31-1	2" DR. HEAD SPACER
31	1	4E-08-1	CHAIN GUARD FOR RMC
32	1	4E-67-1	RMC CHAIN GUARD COVER
33	2	CP-3050	HEX SERRATED FLANGE SCREW 0.375-16x2.500" ZINC PLATED

Part numbers listed in this document are for reference only. When buying replacement parts please provide your conveyor model & serial number to ensure the correct part.