

SECTION VIII. PARTS LISTS AND 3-D DRAWINGS

RMSC CONVEYOR - ASSEMBLED VIEW

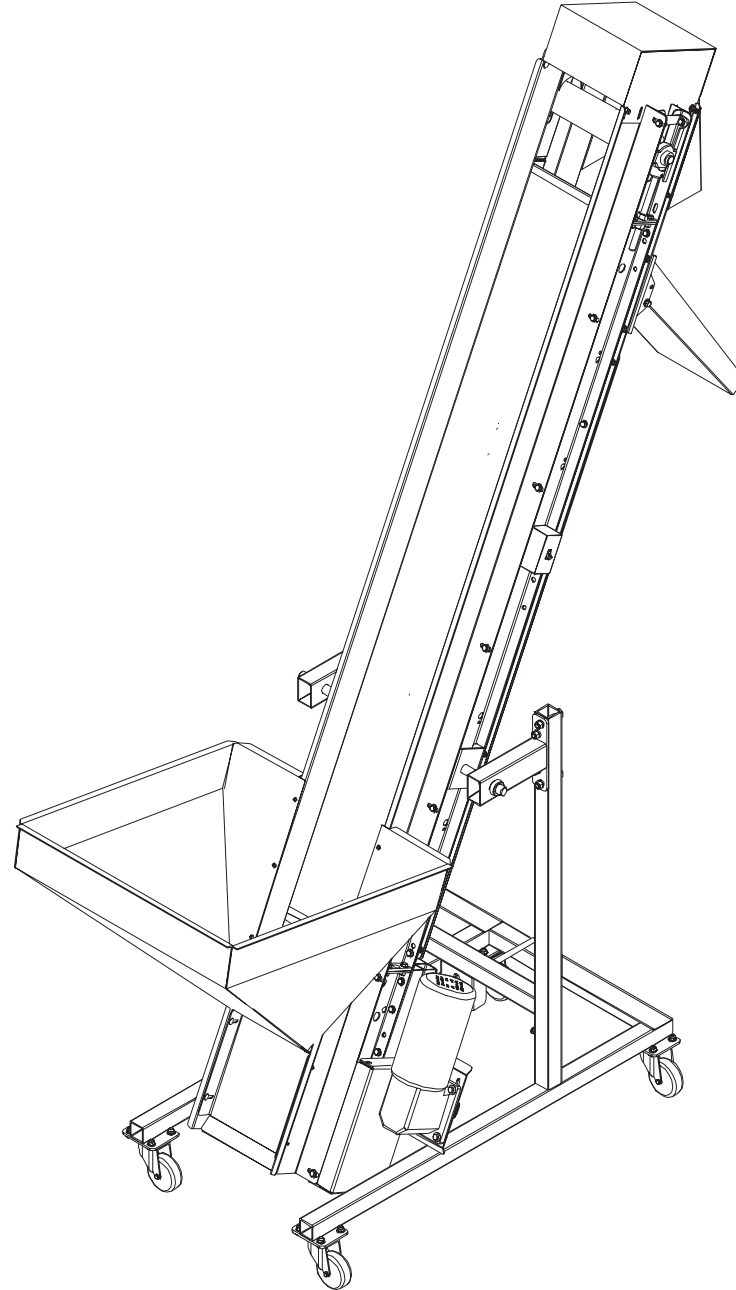

SECTION VIII. PARTS LISTS AND 3-D DRAWINGS

RMSC CONVEYOR - CATALOG VIEW

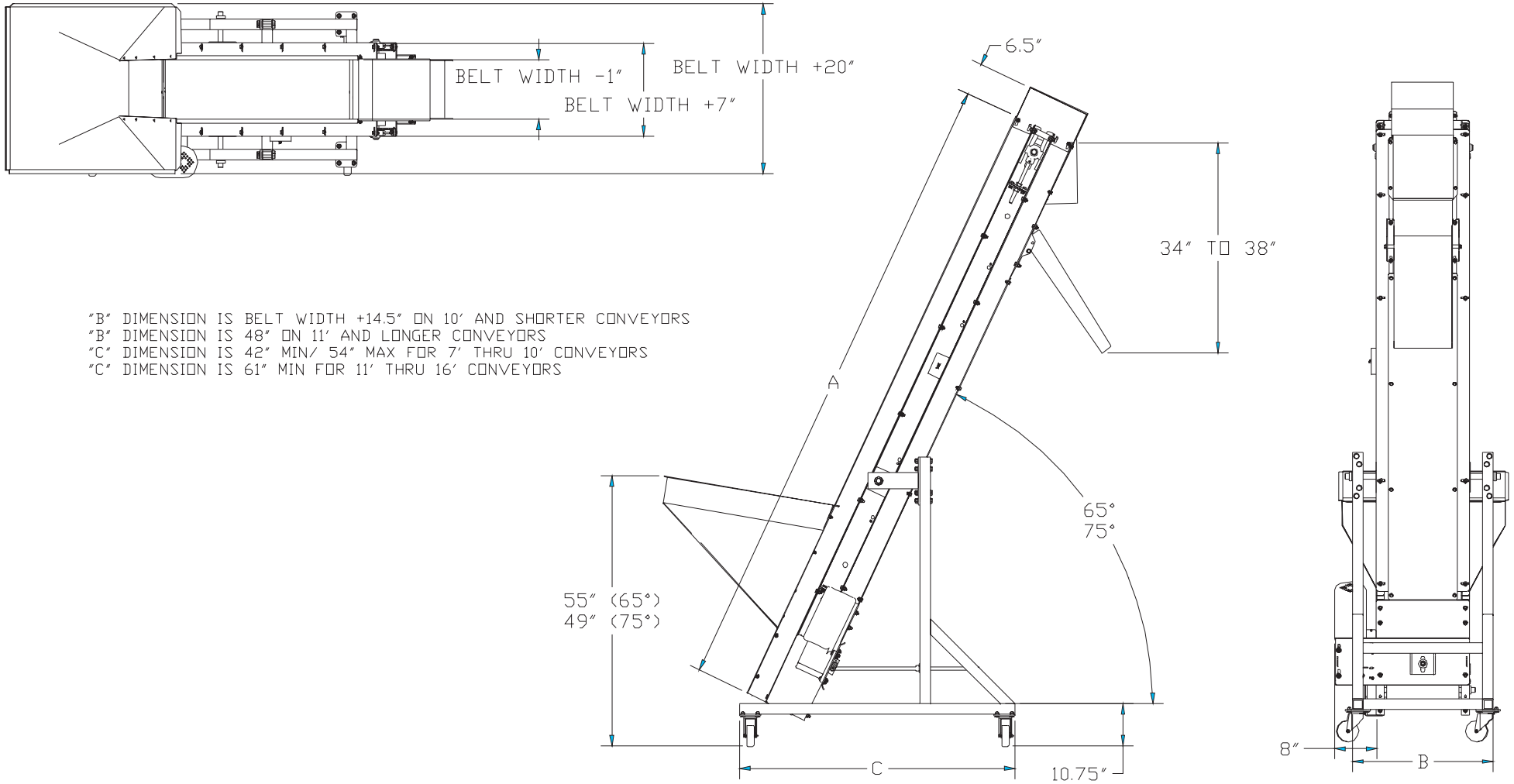

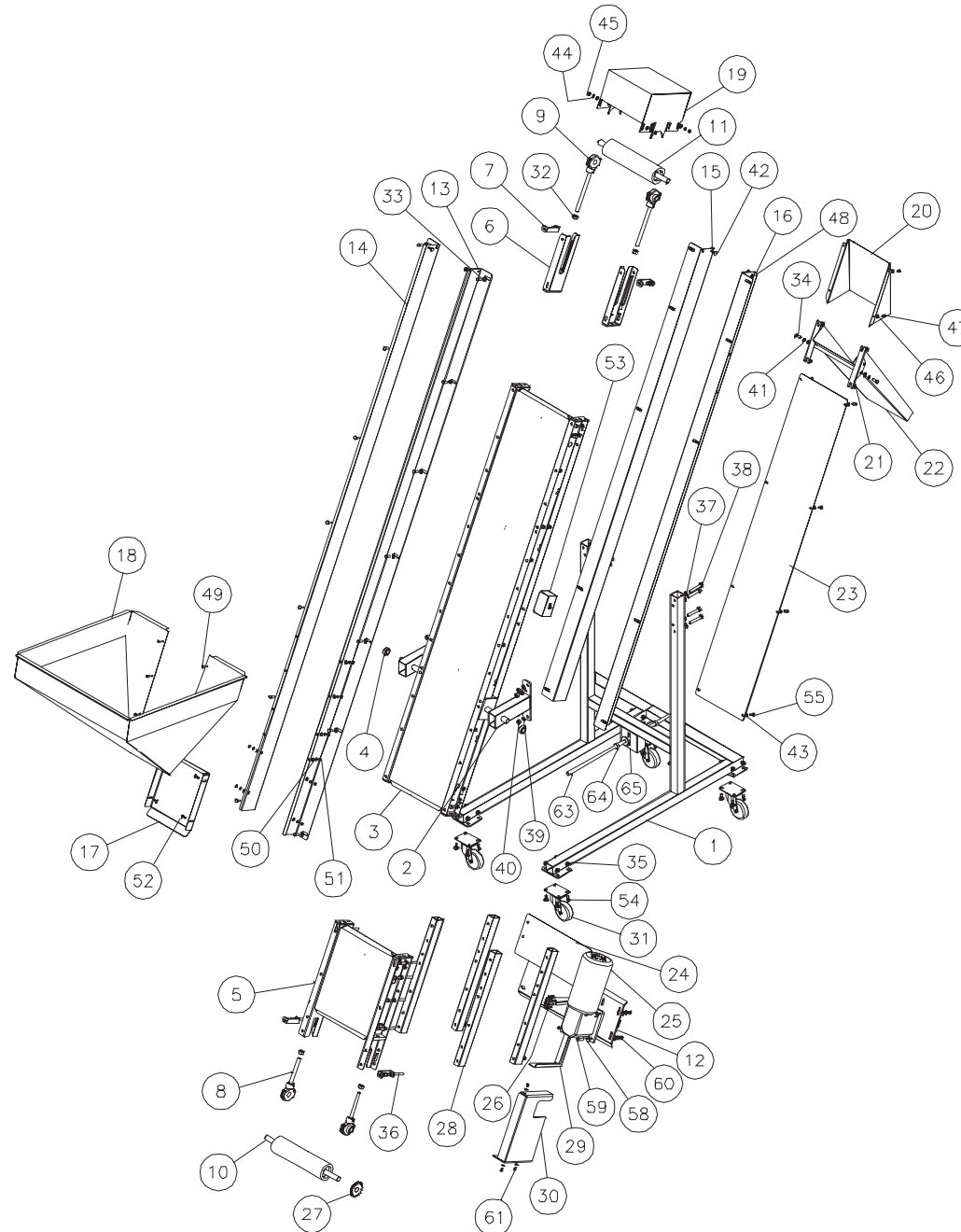
SECTION VIII. PARTS LISTS AND 3-D DRAWINGS**RMSC CONVEYOR - EXPLODED VIEW**

RMSC CONVEYOR PARTS LIST

ITEM	QTY	PART DESCRIPTION	EMI P/N	ITEM	QTY	PART DESCRIPTION	EMI P/N
1	1	LEG STAND	See BOM	34	38	3/8-24 x1 HEX BOLT	CP-141
2	2	ARM SUPPORT	2E-229-11	35	62	3/8-24 HEX NUT	CP-521
3	1	FRAME PIVOT ASS'Y	See BOM	36	10	3/8-16x5 HEX BOLT	CP-168
4	2	LOCKING COLLAR	CP-1201	37	8	1/2 WASHER	CP-658
5	1	DRIVE ASS'Y	4E-204-1-W	38	8	1/2-13x3 HEX BOLT	CP-163
6	2	TAIL ASS'Y	4E-258-2	39	8	1/2 LOCK WASHER	CP-707
7	4	TAKE-UP BRACKET	4E-14-1	40	8	1/2-13 HEX NUT	CP-506
8	2	DRIVE BEARING TAKE-UP ASS'Y	2E-232-3	41	6	3/8 LOCK WASHER	CP-700
9	2	TAIL BEARING TAKE-UP ASSY	2E-232-2	42	4	5/16-18x1 CARRIAGE BOLT	CP-460
10	1	DRIVE PULLEY	2E-210-3-W	43	12	5/16 WASHER	CP-659
11	1	TAIL PULLEY	2E-224-2-W	44	4	5/16 LOCK WASHER	CP-708
12	1	MOTOR SUPPORT	4E-229-41-W	45	4	5/16-18 HEX NUT	CP-518
13	1	LH TOP SIDERAIL	See BOM	46	21	1/4 WASHER	CP-654
14	1	RH TOP SIDERAIL	See BOM	47	4	1/4-28X3/4 HEX BOLT	CP-125
15	1	RH BOTTOM SIDERAIL	See BOM	48	6	1/4-20 HEX NUT	CP-524
16	1	LH BOTTOM SIDERAIL	See BOM	49	8	1/4-20x3/4 HEX SOCKET BUTTON HEAD CAP SCREW	CP-695
17	1	PARTS TRAP	See BOM	50	12	1/4 LOCK WASHER	CP-702
18	1	HOPPER ASS'Y	See BOM	51	12	1/4-28 HEX NUT	CP-517
19	1	HOOD ASS'Y	4E-208-13-W	52	4	1/4-20x1 CARRIAGE BOLT	CP-407
20	1	PARTS DEFLECTOR	2E-34-10-18	53	1	SWITCH	See BOM
21	2	CHUTE BRACKET	2E-14-43	54	16	5/16-18x1 CARRIAGE BOLT	CP-460
22	1	CHUTE	2E-234-7-W	55	8	5/16-18x3/4 HEX BOLT	CP-150
23	1	BOTTOM SLIDE TRAY	See BOM	56	8	5/16-18 HEX NUT	CP-504
24	1	BELT SUPPORT	4E-29-91-18	57	2	1/4-20x1 HEX BOLT	CP-111
25	1	MOTOR AND REDUCER	See BOM	58	8	3/8 WIDE WASHER	CP-671
26	1	SPROCKET	See BOM	59	4	3/8-24x1-1/2 HEX BOLT	CP-137
27	1	SPROCKET	See BOM	60	4	3/8-16 HEX NUT	CP-521
28	4	SUPPORT TUBES	4E-31-1	61	3	1/4-20x1/2 SLOTTED ROUND HEAD CAP SCREW	CP-275
29	1	CHAIN GUARD - LH	4E-08-23	62	1	1/4x2 SLOTTED SPRING PIN	CP-1165
30	1	CHAIN GUARD COVER - LH	4E-67-4	63	1	THREADED ROD	See BOM
31	4	COLSON CASTOR	CP-1484	64	3	5/8-11 HEX NUT	CP-505
32	8	5/8-11 HEX NUT	CP-505	65	2	5/8 WIDE WASHER	CP-663
33	48	3/8 WASHER	CP-662				

Part numbers listed in this document are for reference only. When buying replacement parts please provide your conveyor model & serial number to ensure the correct part.