

**SECTION VIII. PARTS LISTS AND 3-D DRAWINGS**

## STLC CONVEYOR - ASSEMBLED VIEW

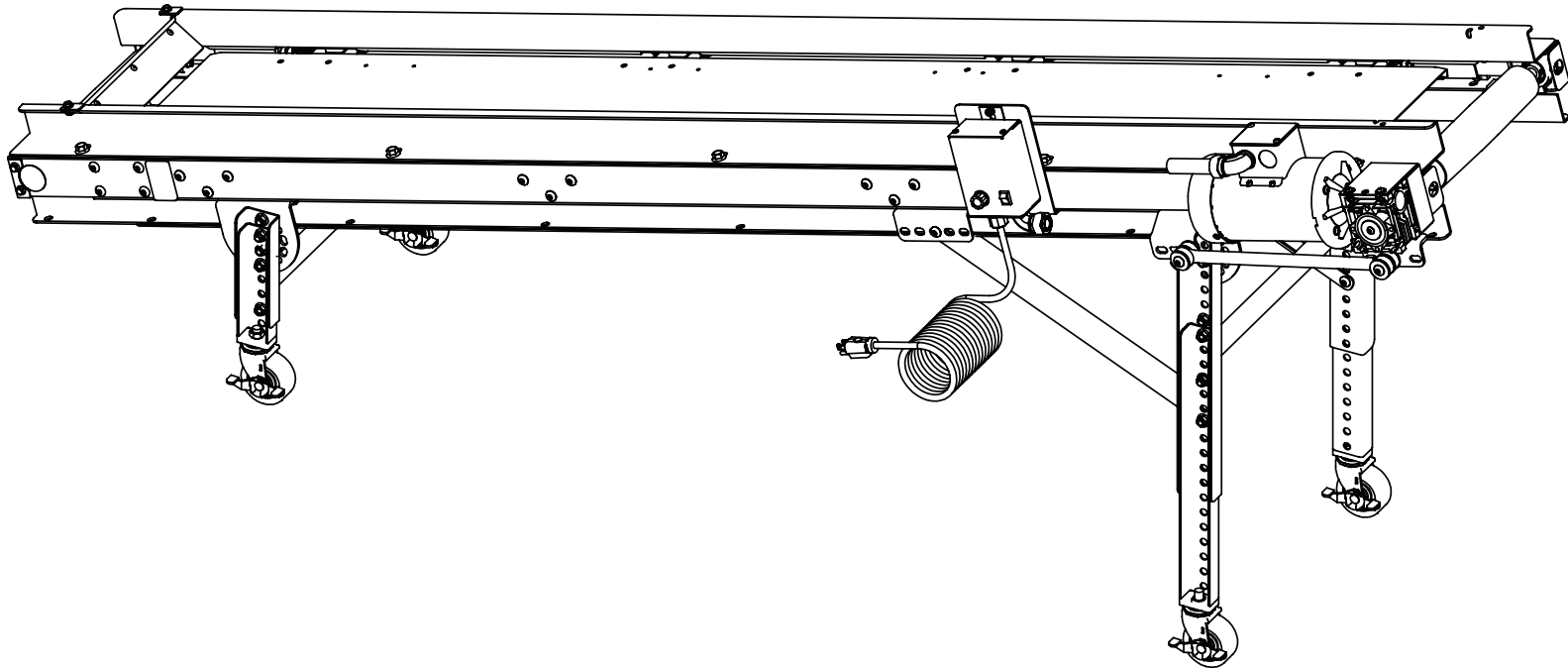

# SECTION VIII. PARTS LISTS AND 3-D DRAWINGS

## STLC CONVEYOR - CATALOG VIEW

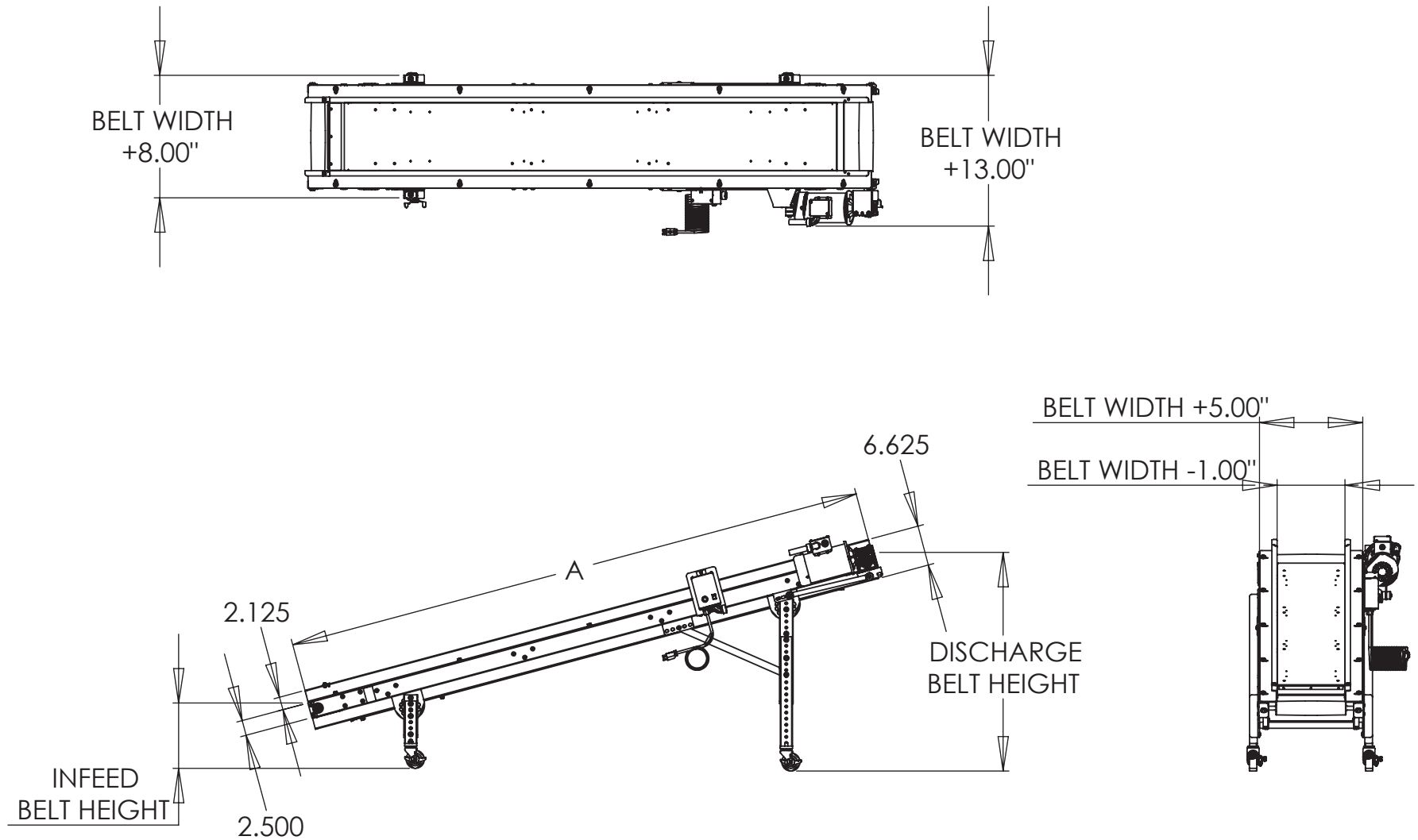



## STLC CONVEYOR PARTS LIST

ITEM	QTY	PART DESCRIPTION	PART #
1	1	FRAME ASSEMBLY	2S-206-4-L-W-2
2	4	TAKE-UP	2L-232-11
3	1	DRIVE PULLEY	2L-10-5-W
4	1	TAIL PULLEY	2L-24-2-W
5	1	FLAPPER ASSEMBLY	4E-249-16-W
6	2	FLAPPER CLIP	2E-01-10
7	2	SIDE RAIL	2S-33-1-L-2
8	4	CASTOR	CP-1237
9	4	LEG	CALL
10	4	LEG EXTENSION	CALL
11	4	LEG MOUNTING BRACKET	2M-14-16
12	2	CROSS BRACE	2S-241-2-W
13	2	KNEE BRACE - CONSULT FACTORY	CALL
14	2	LEG BRACE SUPPORT	2M-14-11
15	2	BOTTOM SLIDE TRAY SIDE	2S-44-2-L-2
16	1	BOTTOM SLIDE TRAY	2S-45-2-L-W-2
17	1	REACTION ROD	2M-38-1
18	1	MOTOR SUPPORT BRACKET	2M-14-29
19	1	MOTOR MOUNTING BRACKET	2L-14-4
20	1	MOTOR COVER	2L-08-3
21	1	GEARBOX	SEE SPEC SHEET
22	1	MOTOR	SEE SPEC SHEET
23	1	VARIABLE SPEED CONTROL	SEE SPEC SHEET
24	1	CONTROL MOUNTING PLATE	2L-27-2
25	3	1.5" ROUND CAP	CP-3477
26	4	1.5" X 2.5" RECTANGULAR CAP	CP-3532
27	2	SIDE RAIL SPACER	2L-31-1-L-2
28	4	FRAME END GUARD	2L-09-4-2

ITEM	QTY	PART DESCRIPTION	PART #
29	57	3/8-16 X 3/4" HHCS	CP-3293
30	10	1/4-20 X 1/2" HEX FLANGE SCREW	CP-304
31	10	3/8-16 X 1" HHCS	CP-3325
32	43	3/8-16 SERATED FLANGE LOCKNUT	CP-3299
33	11	1/4-20 X 3/4" HEX FLANGE SCREW	CP-695
34	5	3/8" FLAT WASHER	CP-3342
35	6	1/4" FLAT WASHER	CP-3340
36	2	1/4-20 LOCKNUT	CP-3297
37	4	1/2-13 HEX HALF-NUTS	CP-508
38	1	5/8 X 1-1/8 X 1/2" SET SCREW COLLAR	CP-1200
39	1	1/4 X 1-1/4 FENDER WASHER	CP-591
40	4	3/8" FLAT WASHER	CP-3342
41	2	#10-32 X 1/2" RHMS	CP-271
42	2	#10-32 HEX NYLON INSERT LOCKNUT	CP-516
43	4	3/16" FLAT WASHER	CP-656
44	2	#10 LIGHT LOCK WASHER	CP-710
45	1	WATER TIGHT ENTRANCE CONNECTOR	EL-358
46	2	90 DEGREE ELBOW	EL-353
47	1	15' POWER CABLE	2E-263-1
48	2	REACTION ROD UNIVERSAL MOUNT	CP-3178
49	4	1/4" LOCK WASHER	CP-3343
50	6	1/4-20 HEX SERATED FLANGE LOCKNUT	CP-3297
51	2	3/8-16 X 2" HHCS	CP-3295
52	1	CONDUIT	4E-62-1
53	1	3/16" SQ. X 1" KEY	CP-1006
54	4	1/8" SPACER, J-LOCK STYLE	2L-31-4-4
55	8	TINNERMAN FASTENER	CP-1418

Part numbers listed in this document are for reference only. When buying replacement parts please provide your conveyor model & serial number to ensure the correct part.