

X & Y axis part removal using linear slides and wide angle gripper

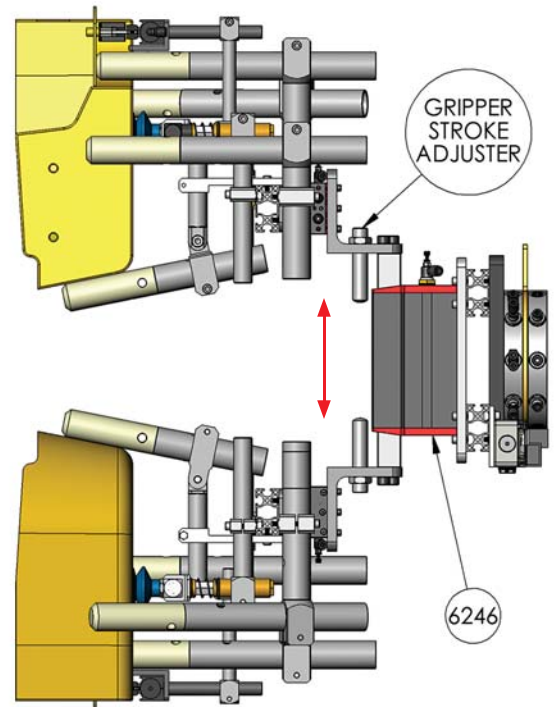

X & Y axis part removal using linear slides and wide angle gripper

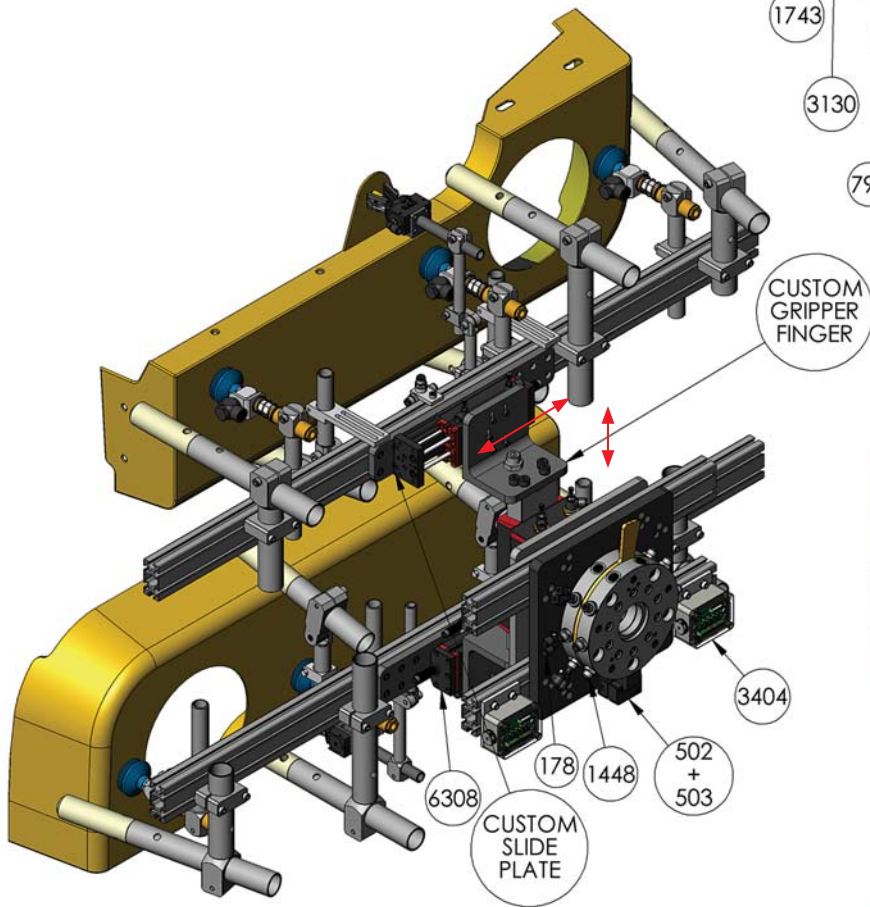
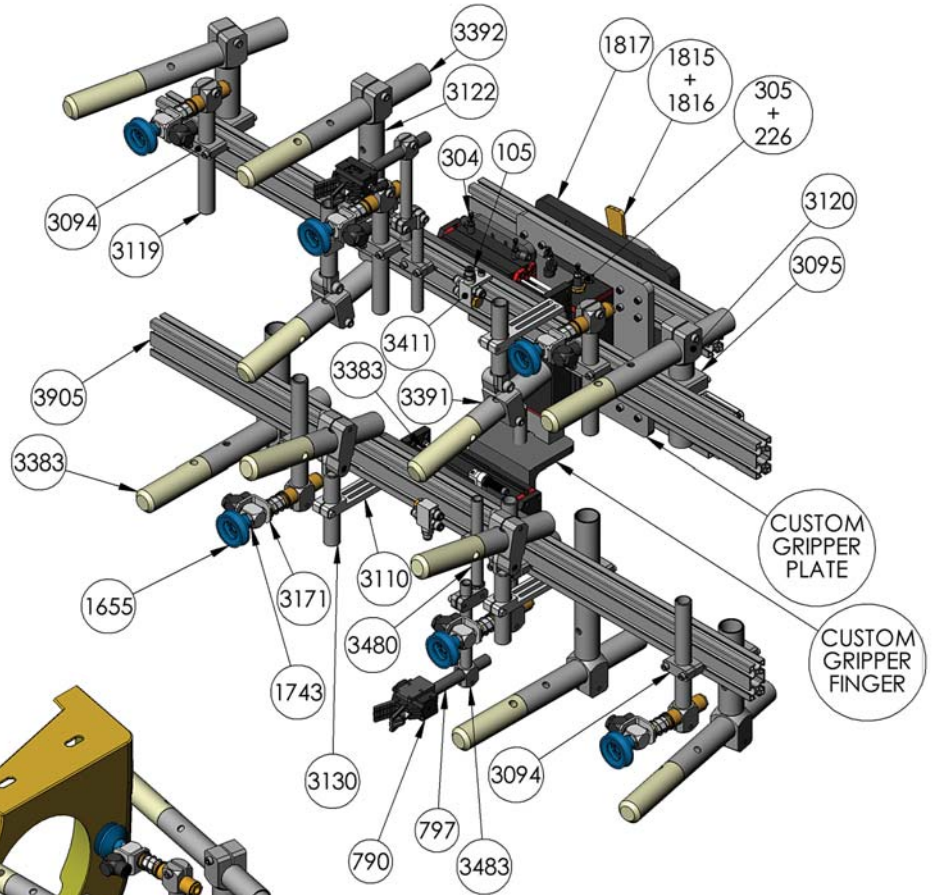
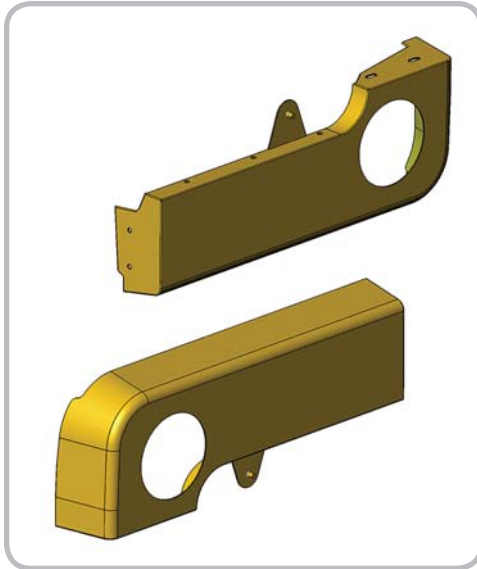
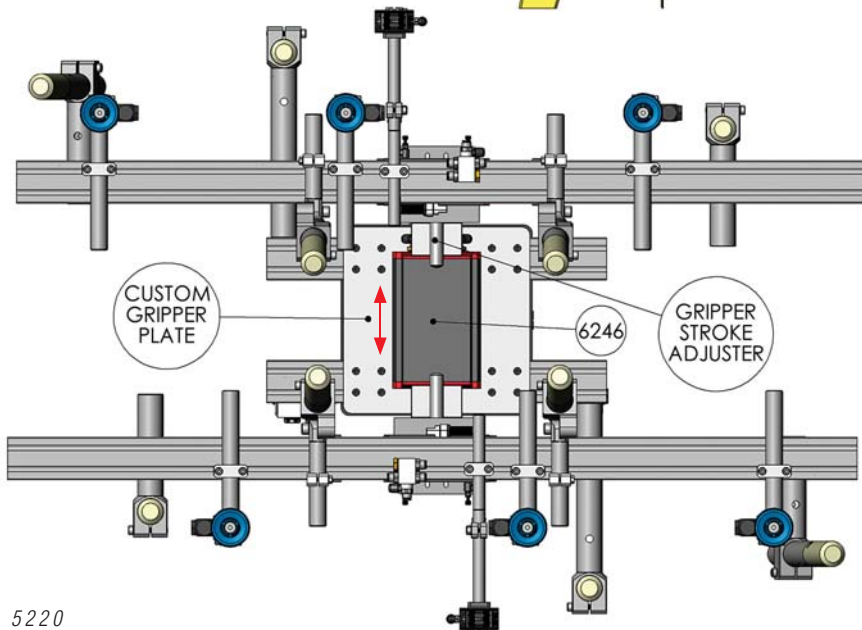
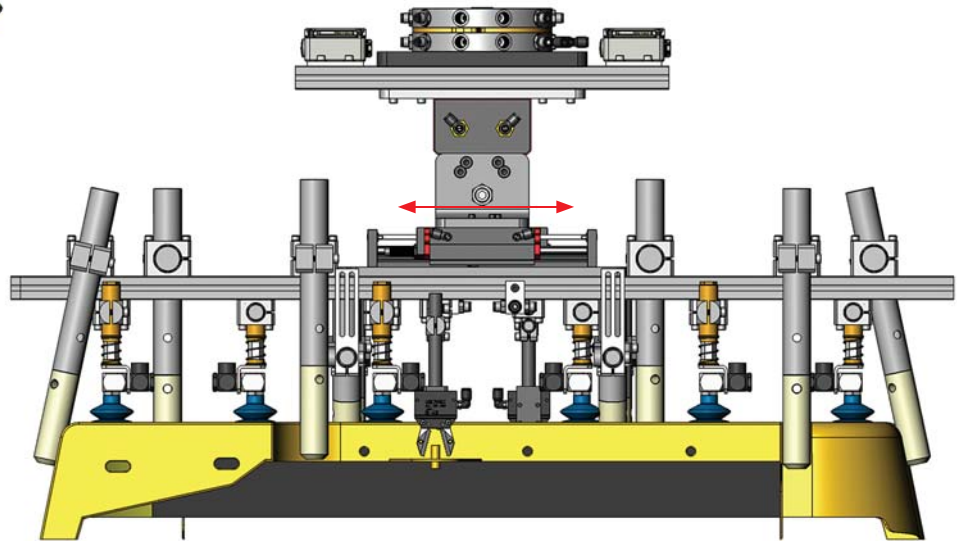
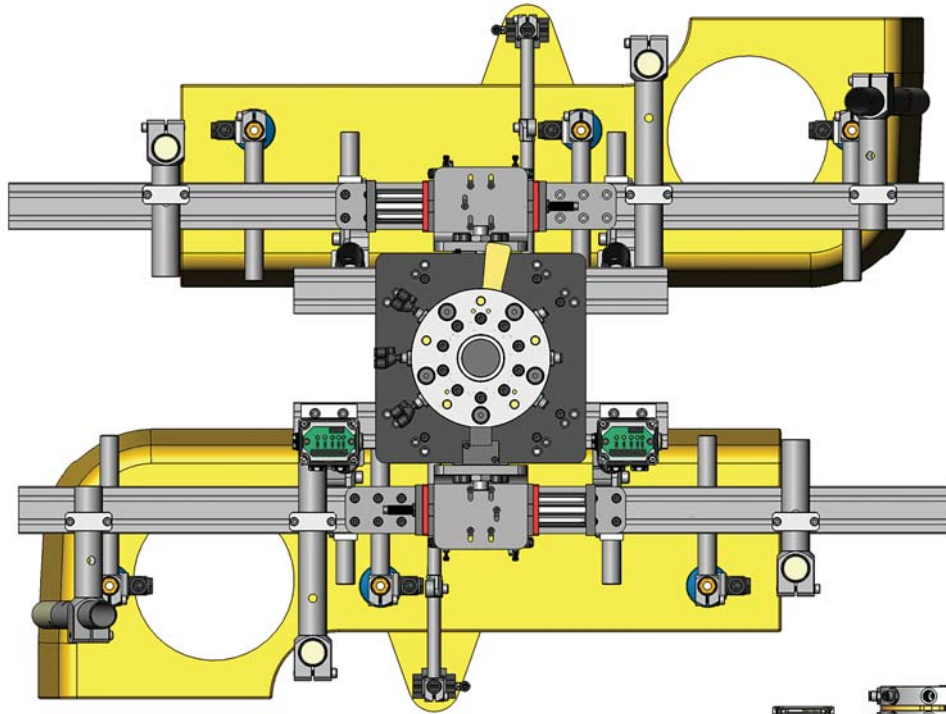

Insert loading from side entry robot

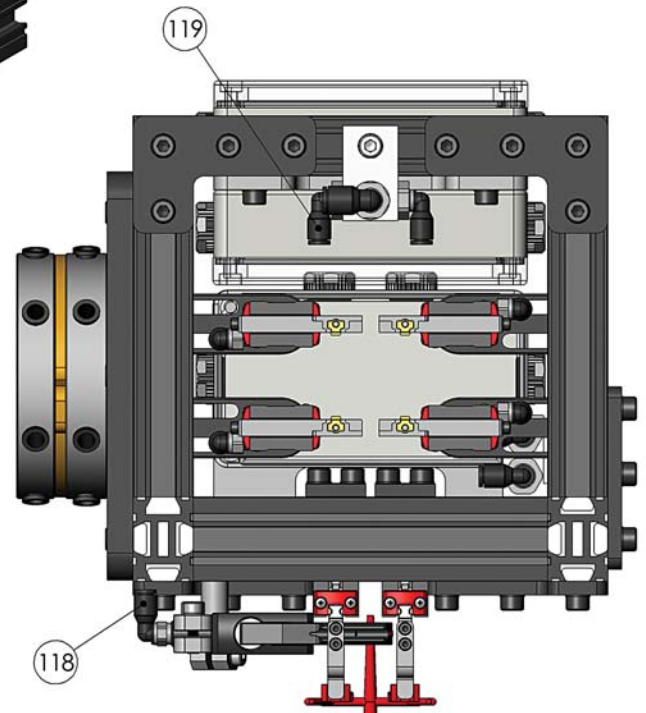
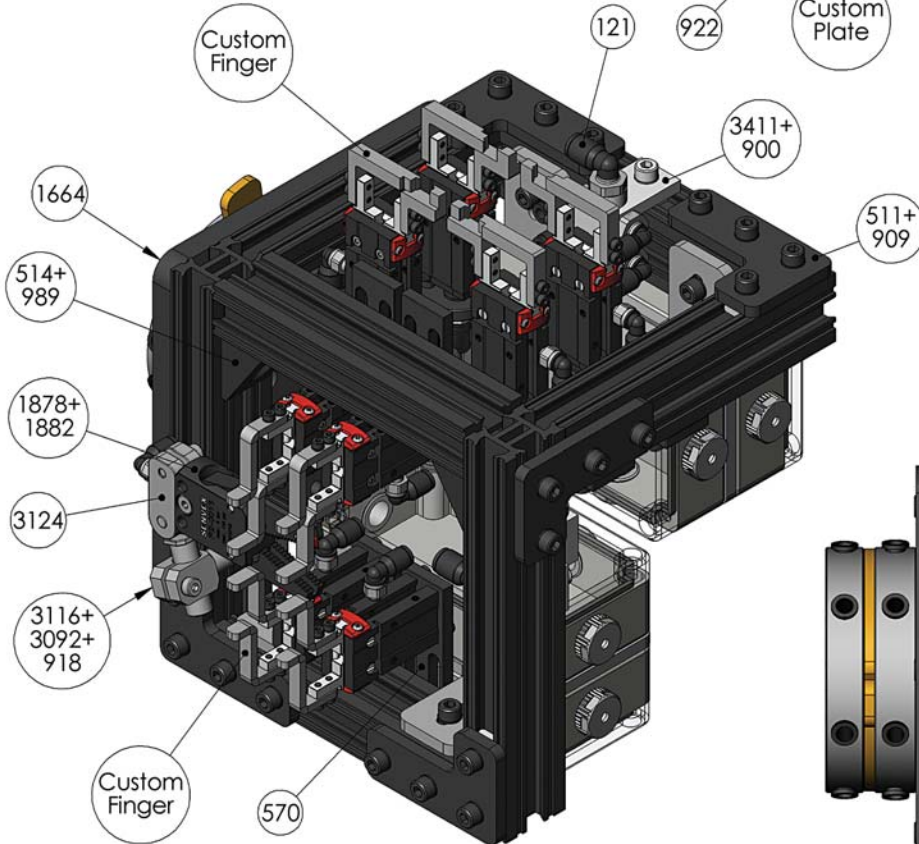
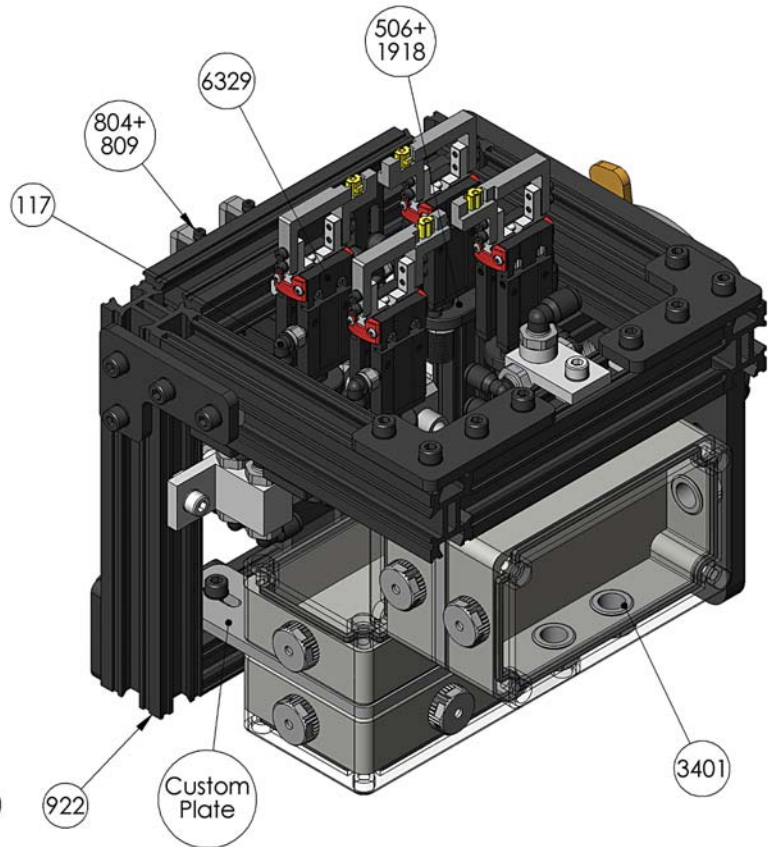
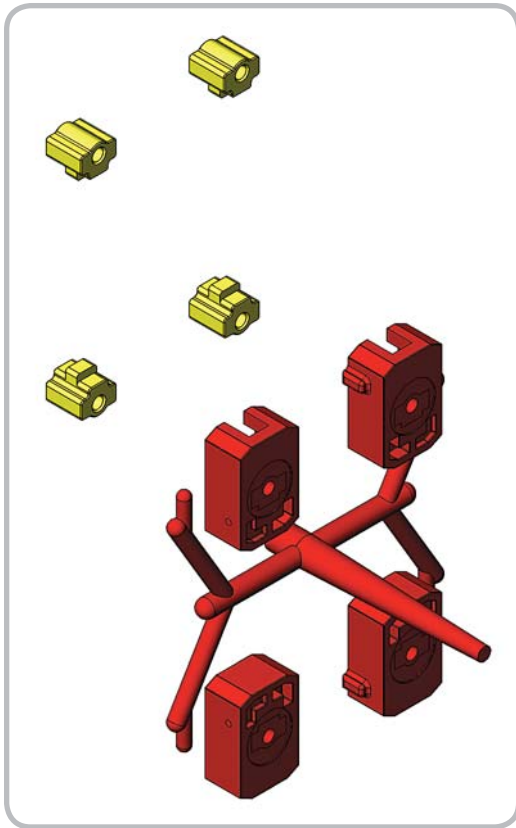

Insert loading from side entry robot

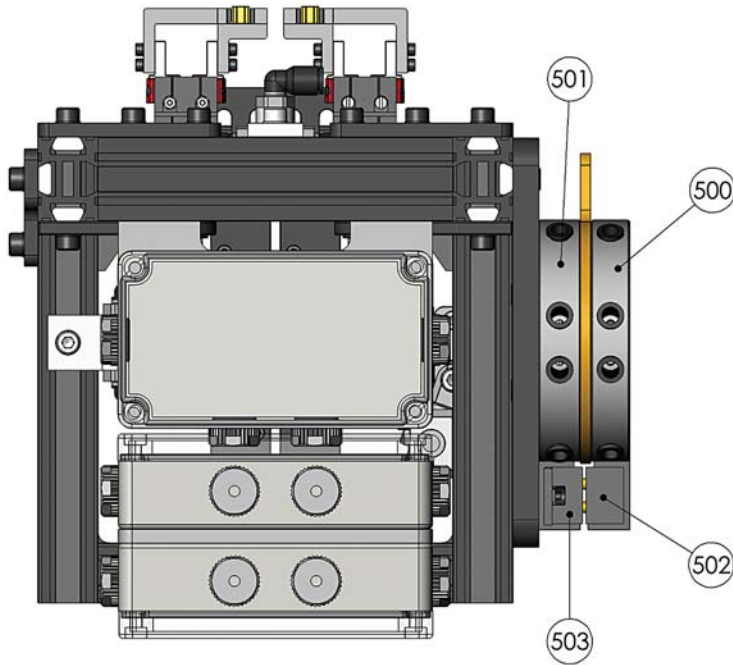

R126 [4.961]

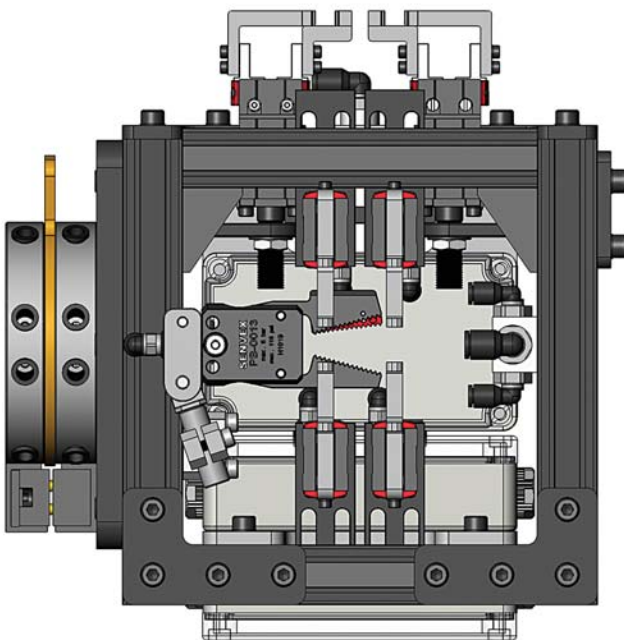
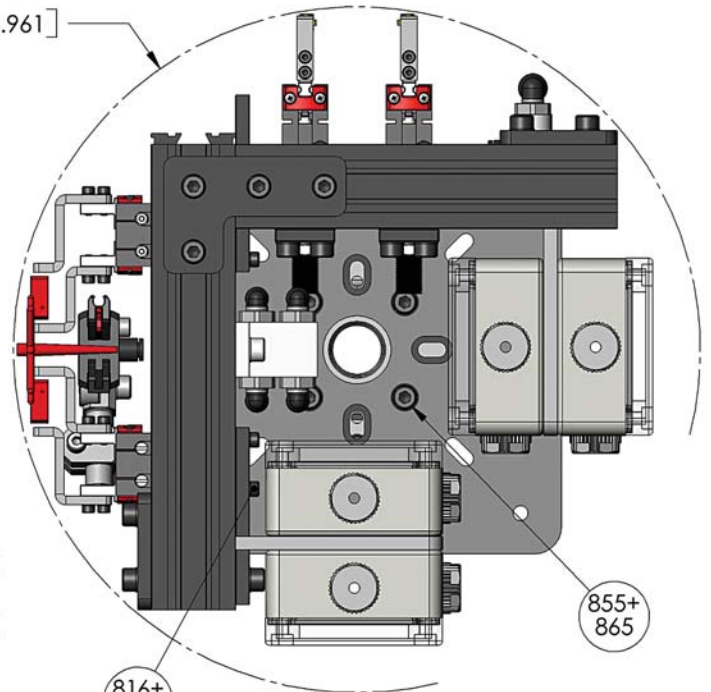

Nippers mounted on linear slides

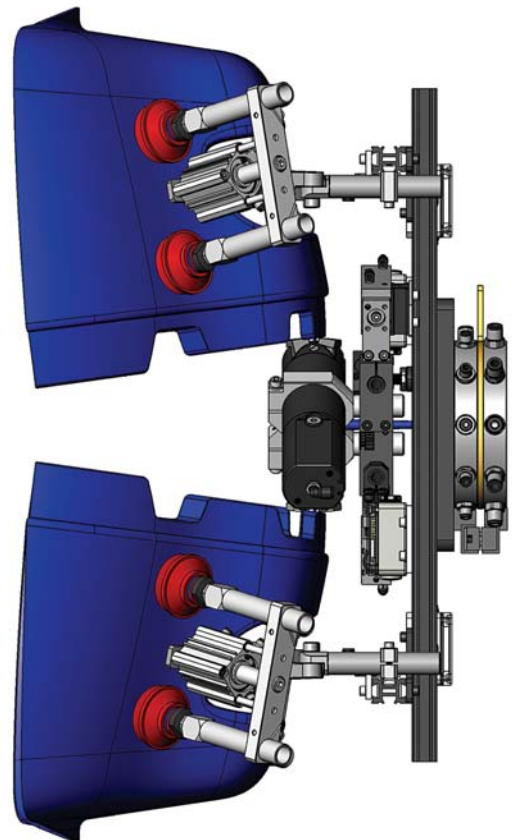
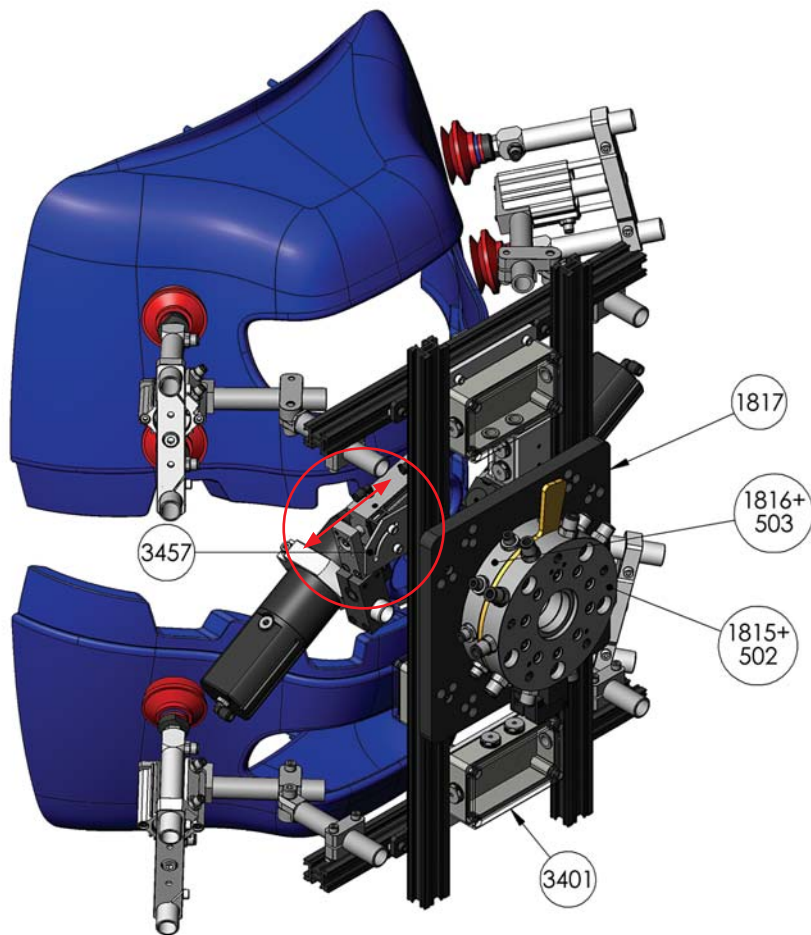
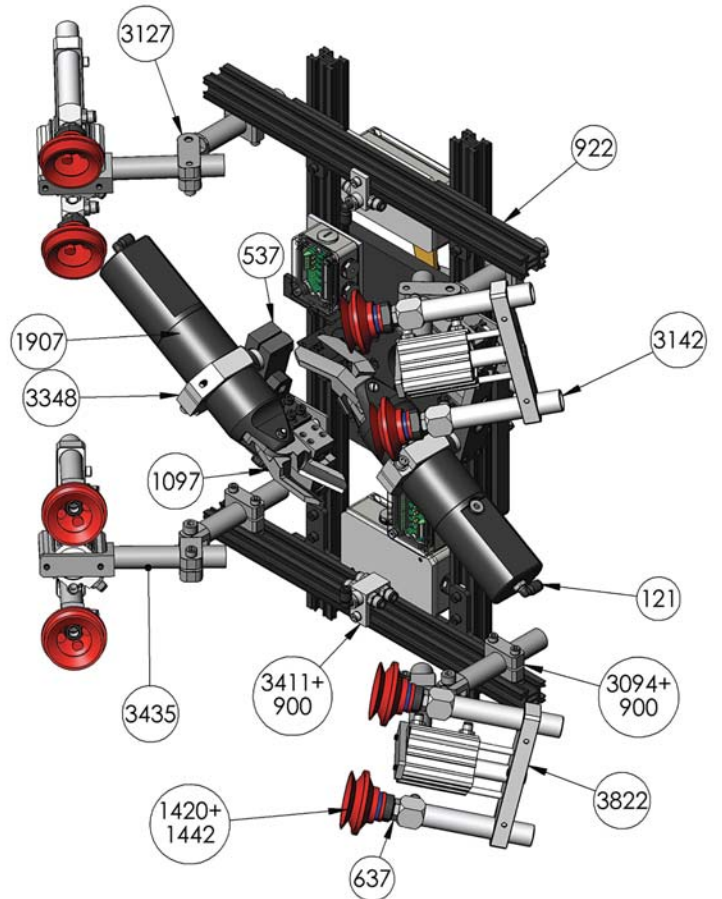

Nippers mounted on linear slides

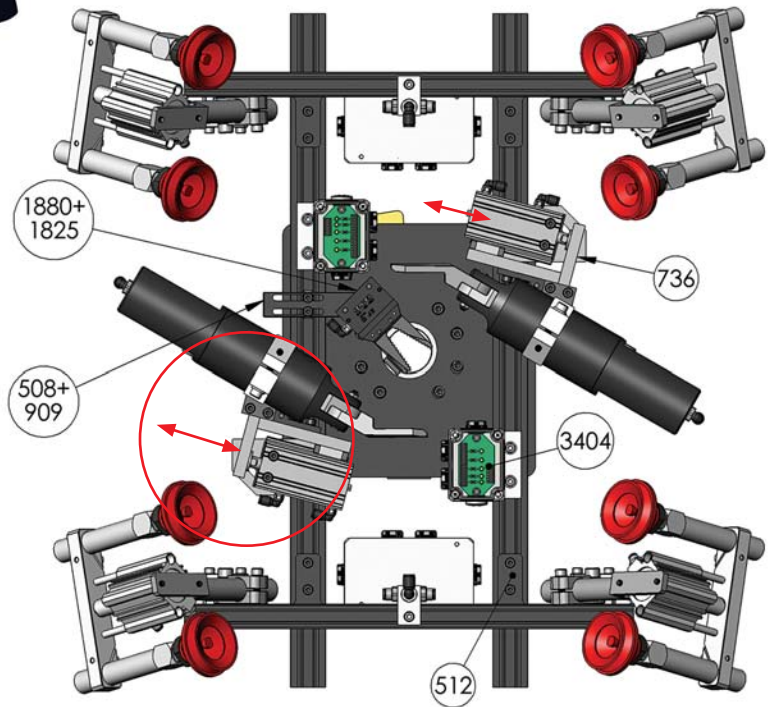
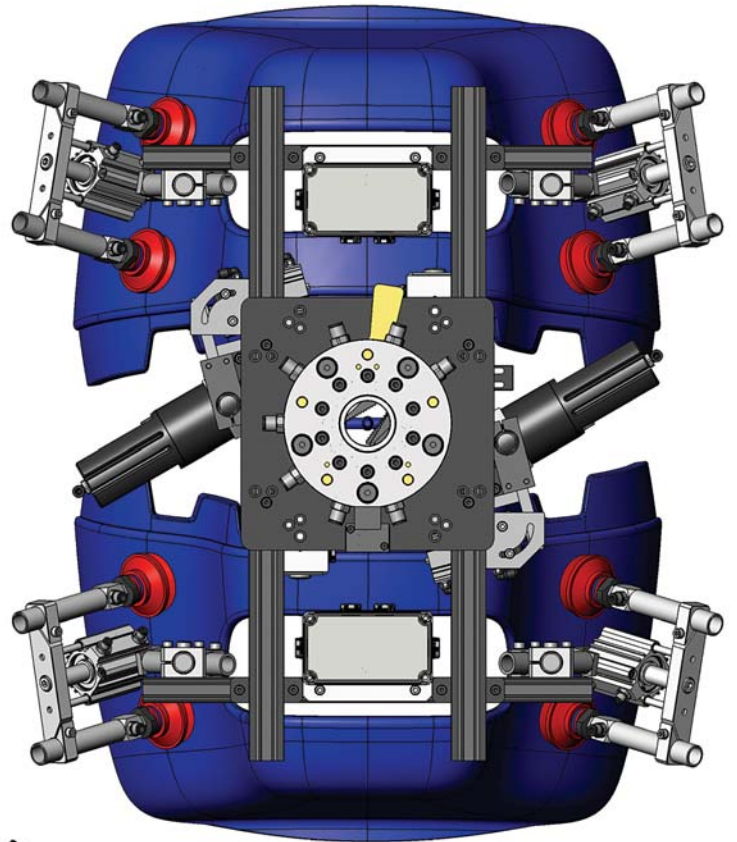
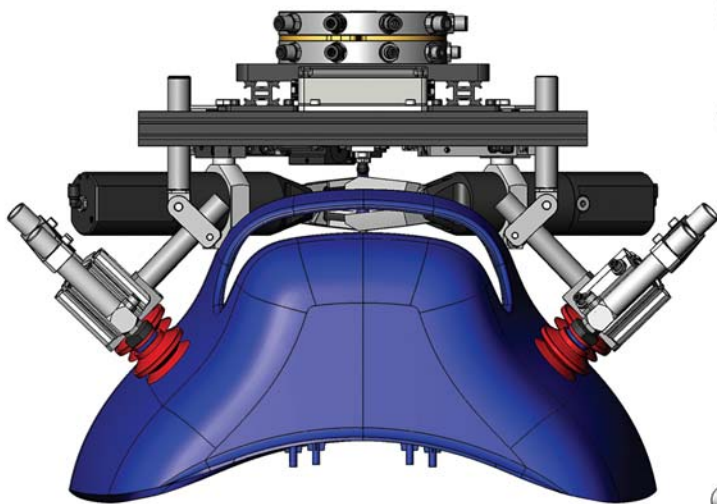

Guide pins to provide part stability

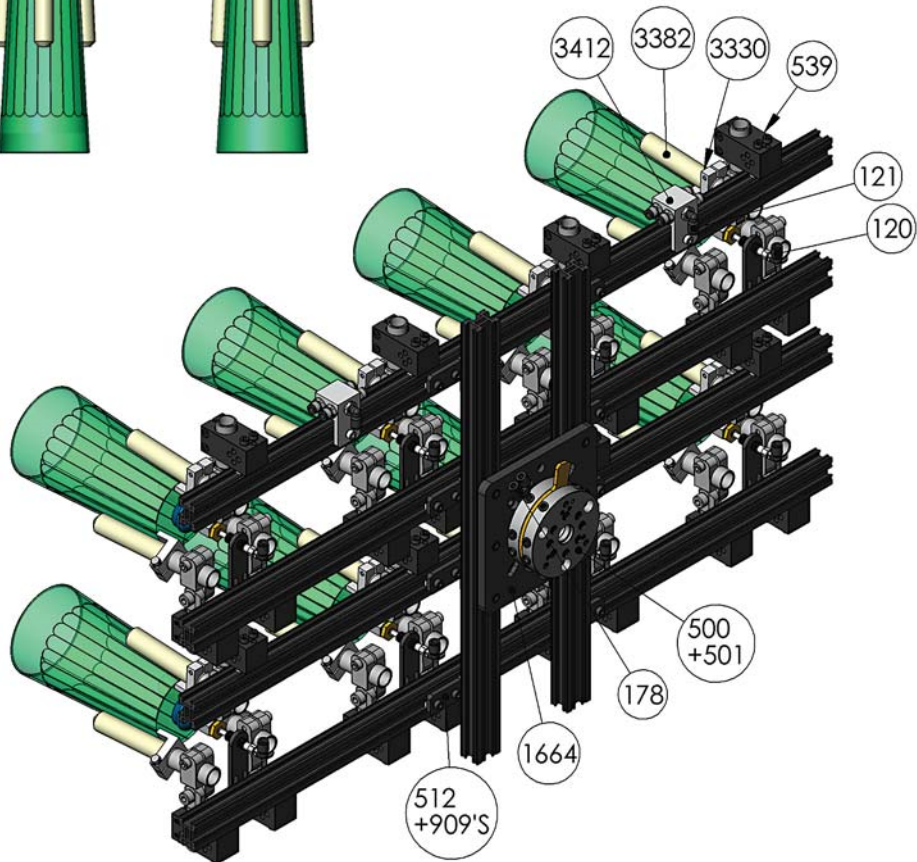
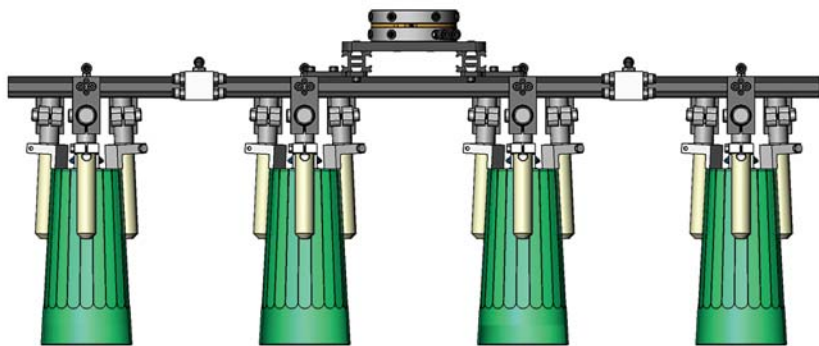
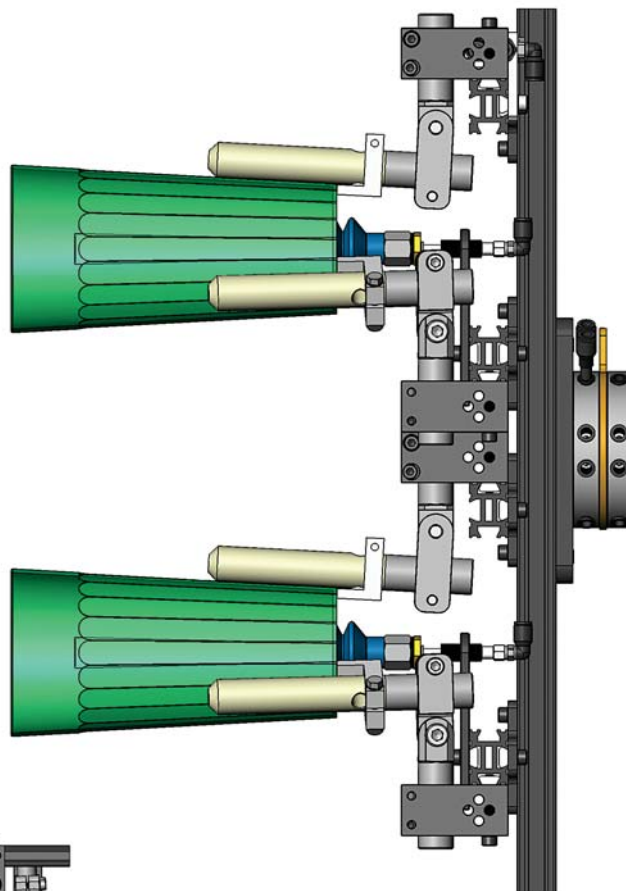
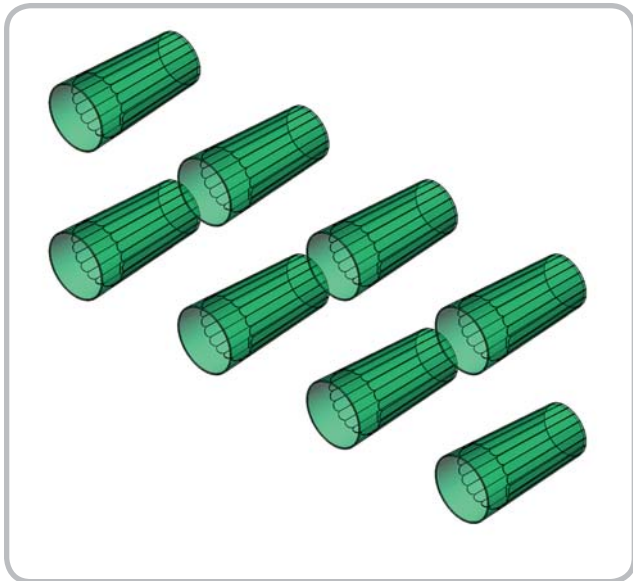

Guide pins to provide part stability

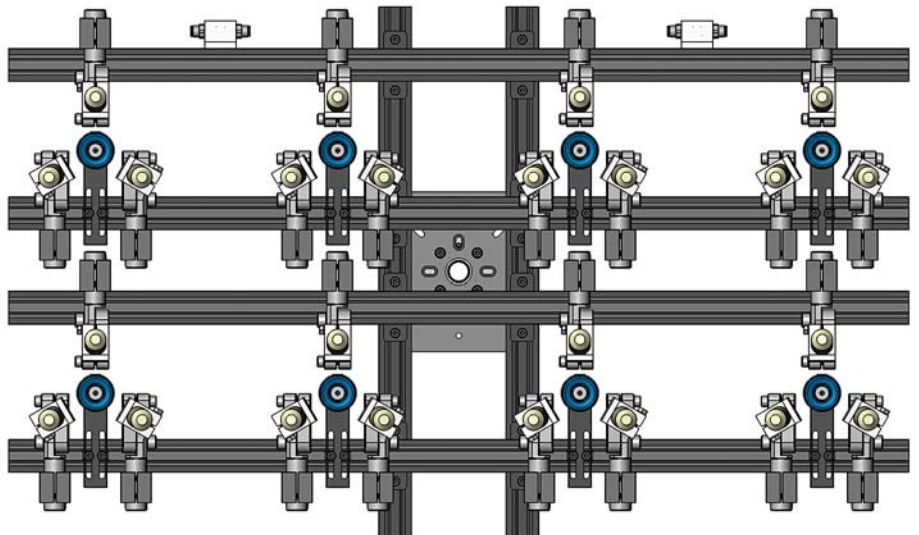
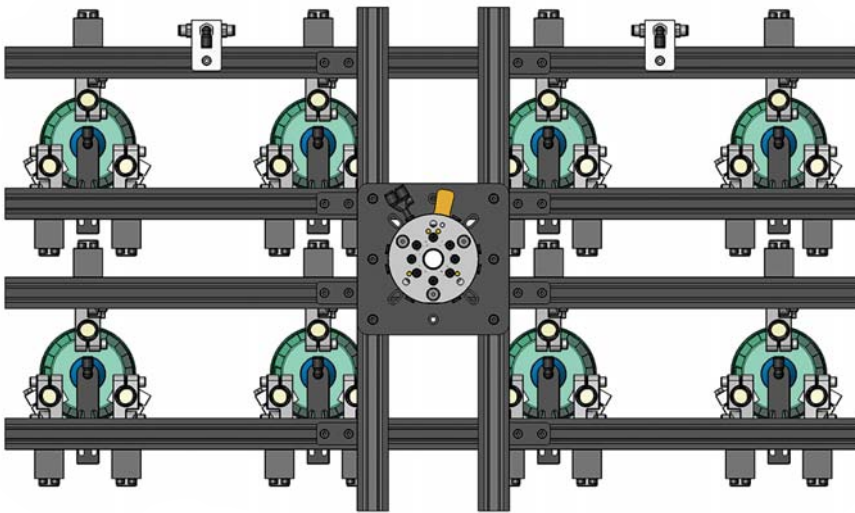
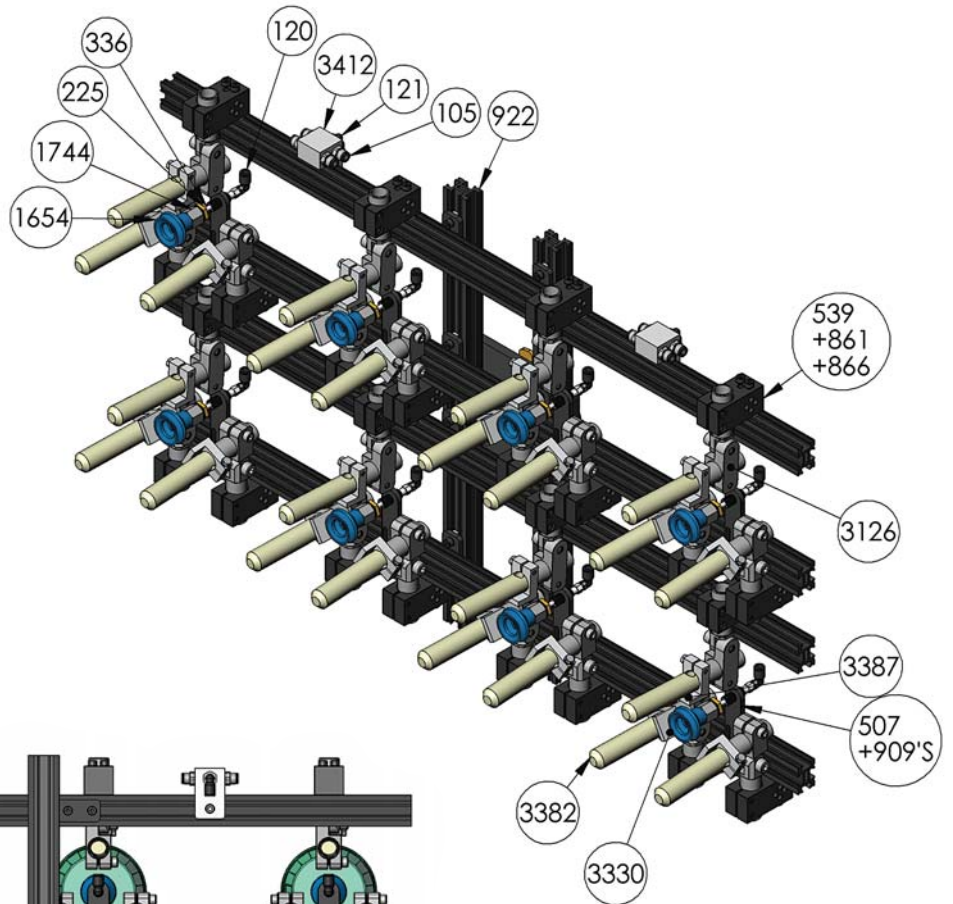

Vacuum cups mounted on grippers

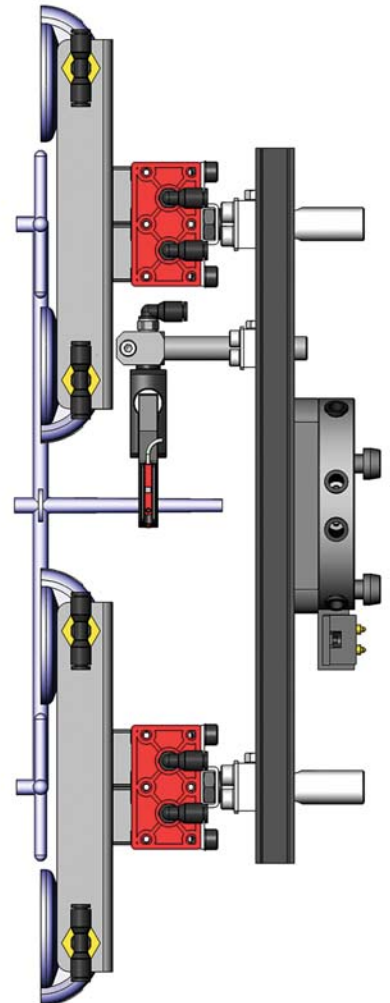
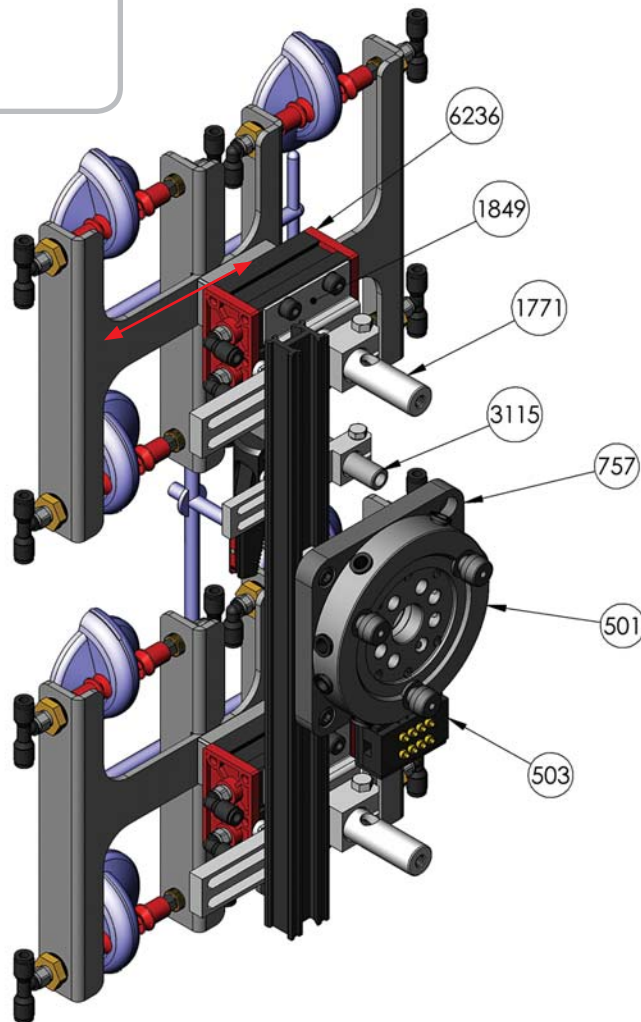
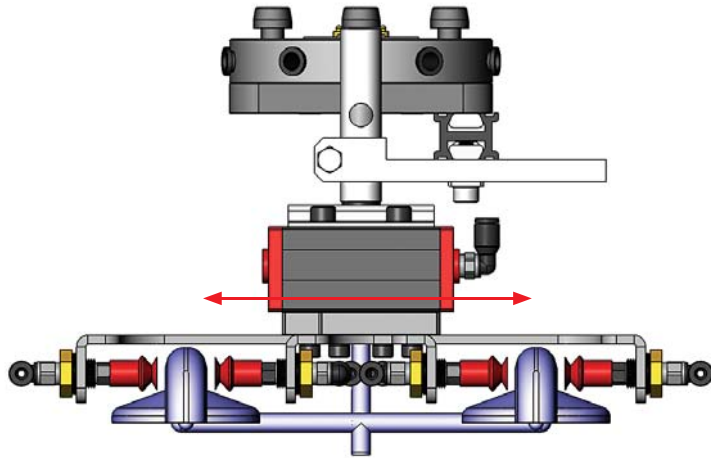
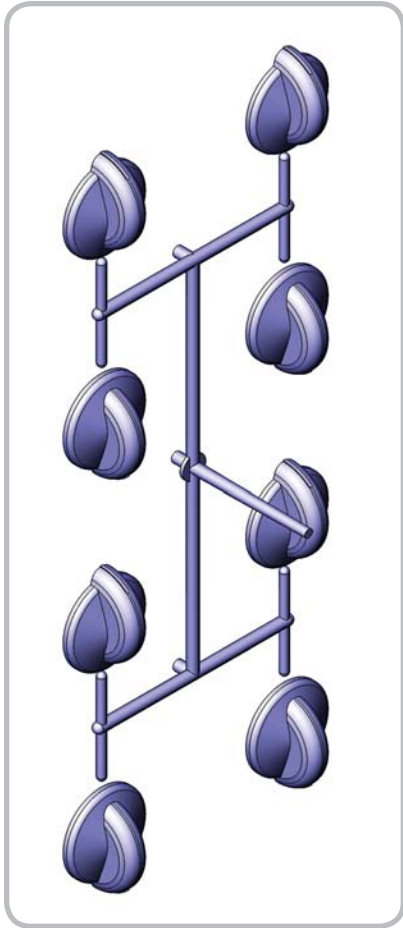

Vacuum cups mounted on grippers

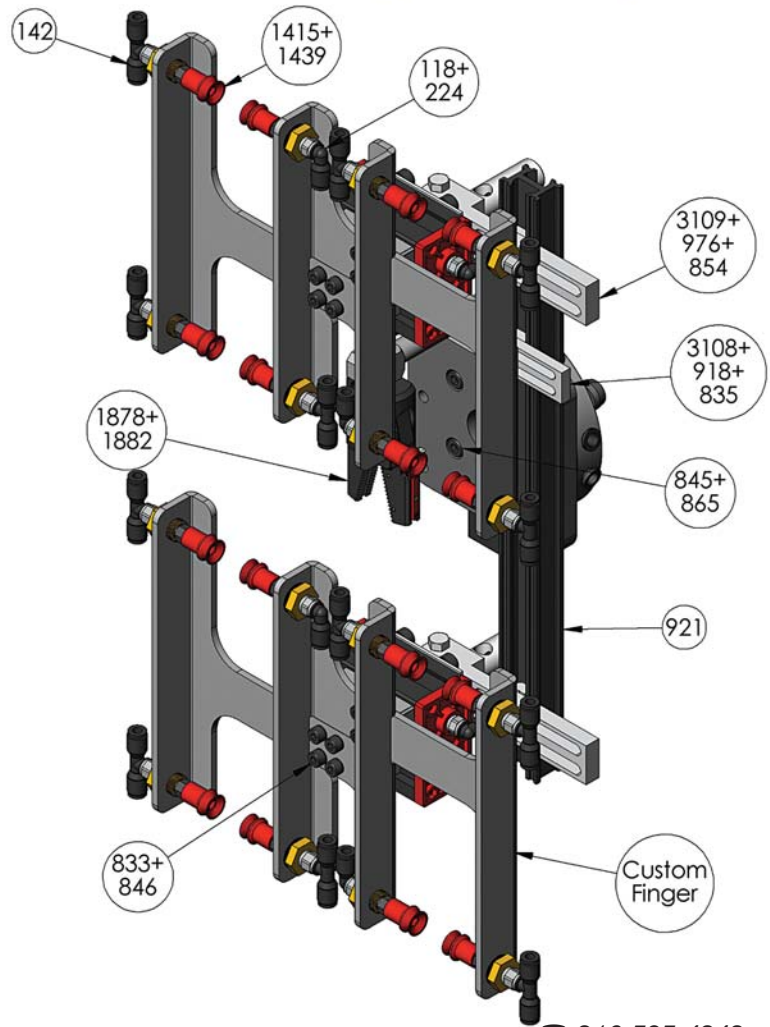
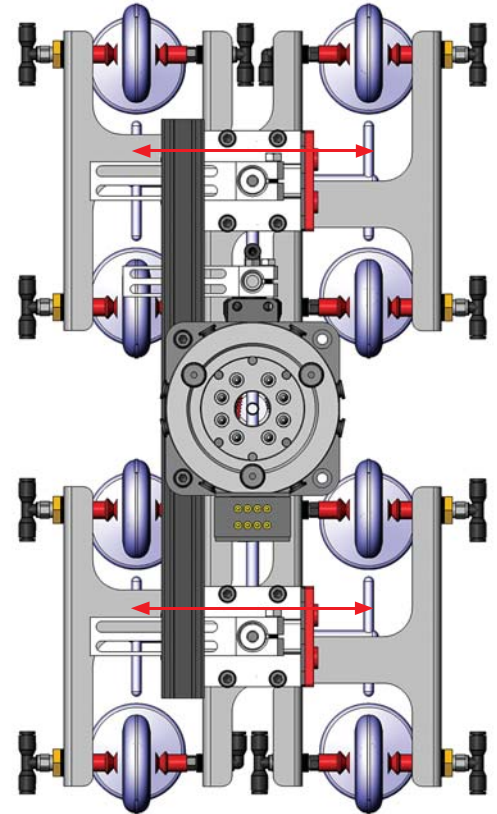
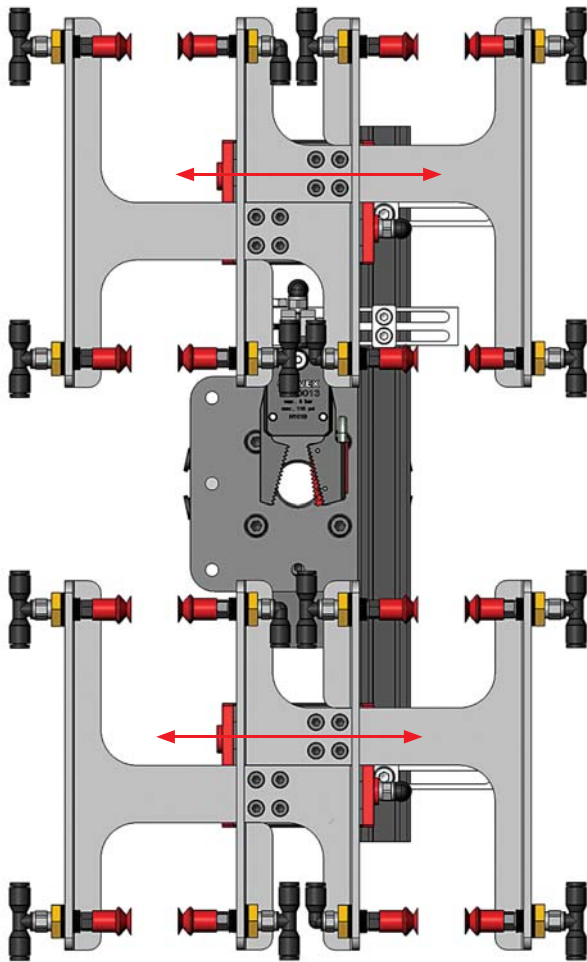

O.D. Air Hands with photoeyes used for part confirmation

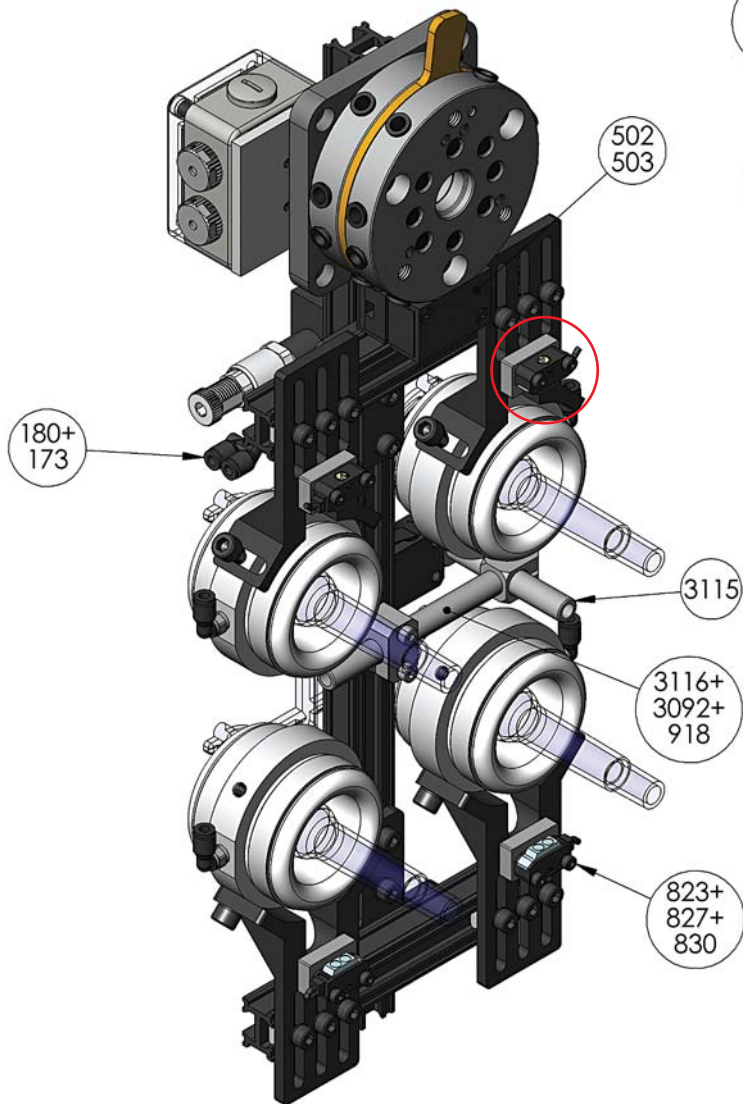
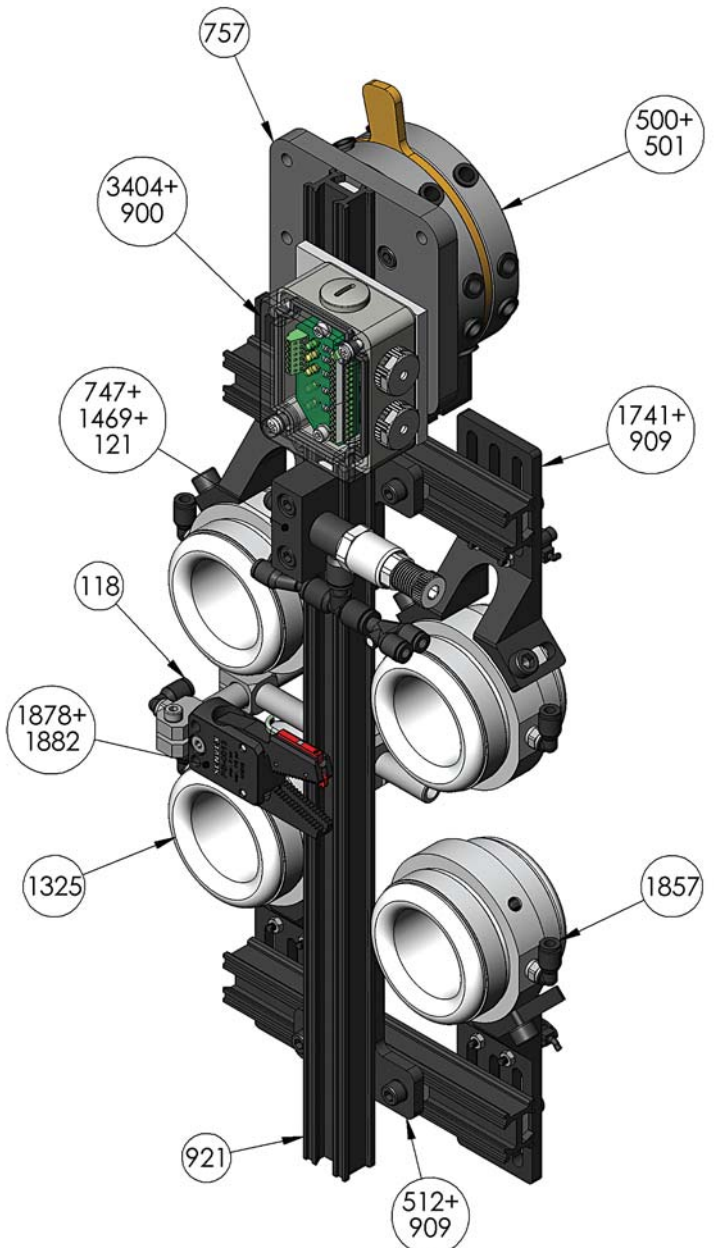
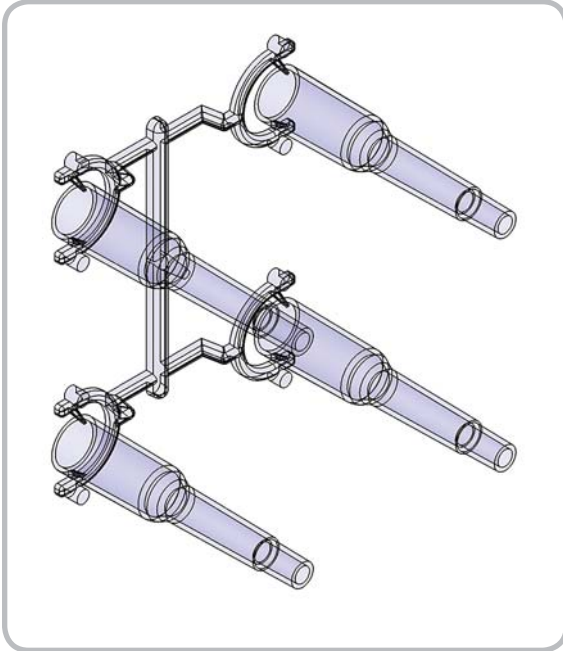

O.D. Air Hands with photoeyes used for part confirmation

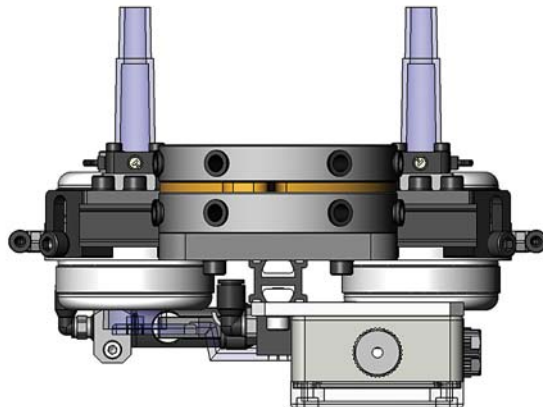
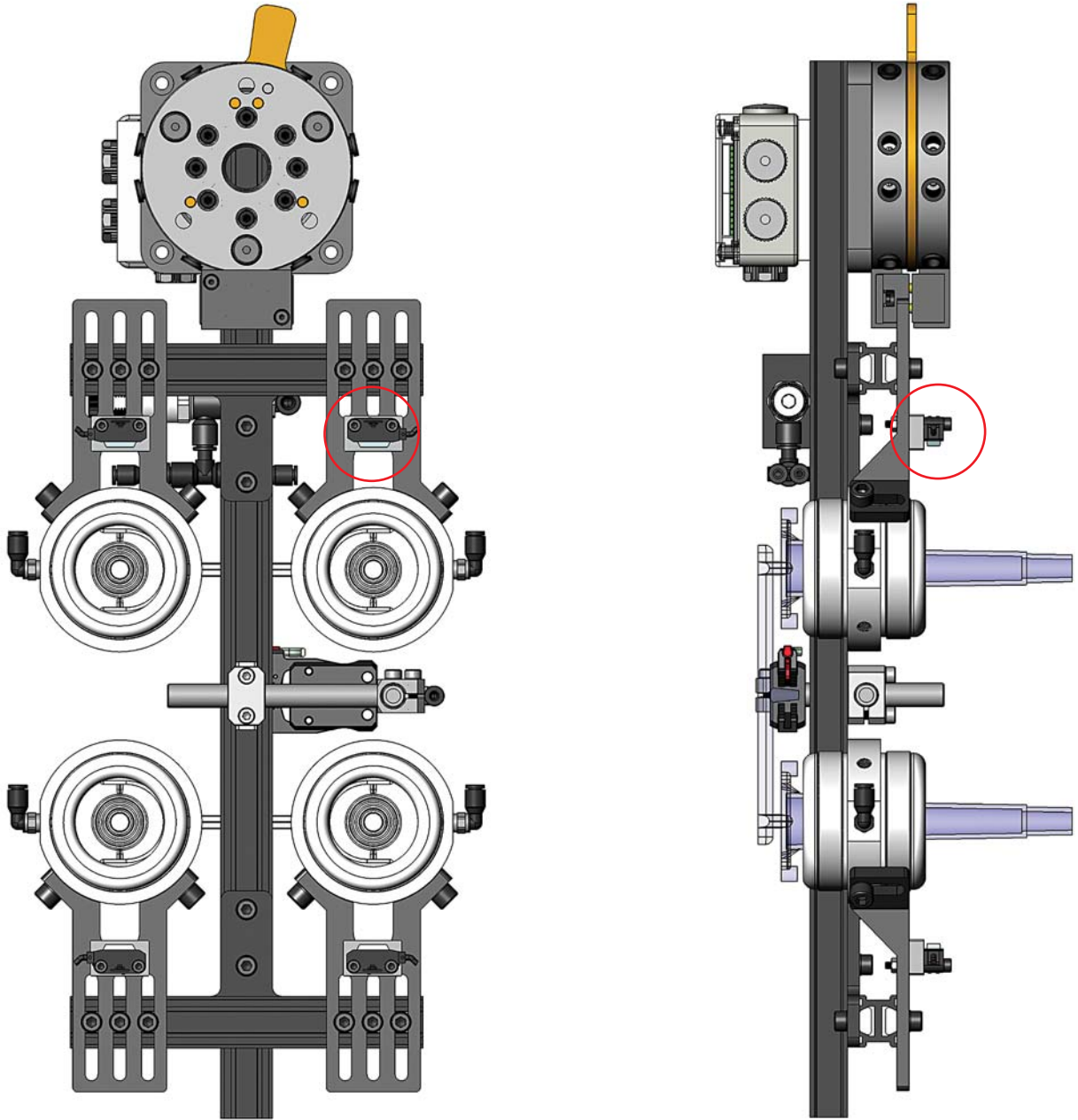

Adjustable width, deep cored part gripping using special cylinders

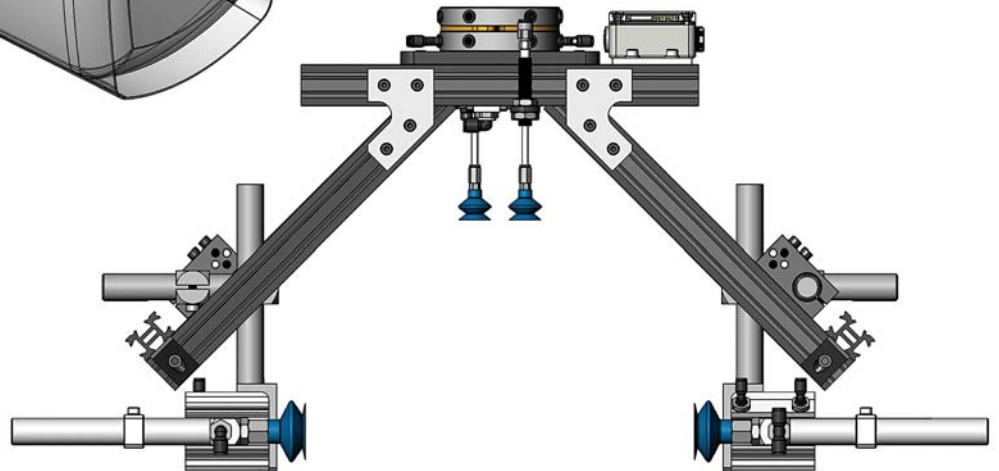
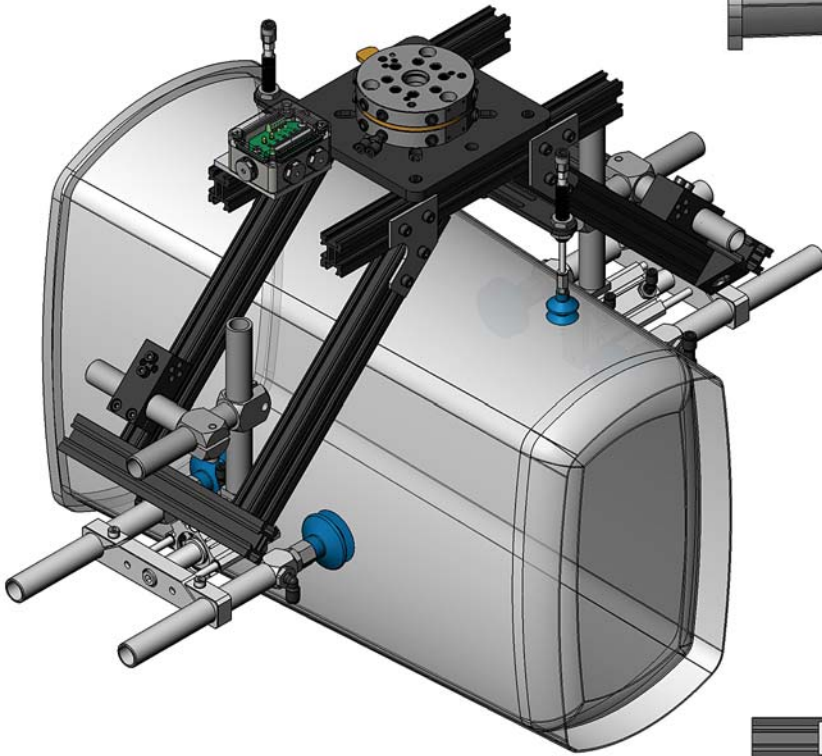
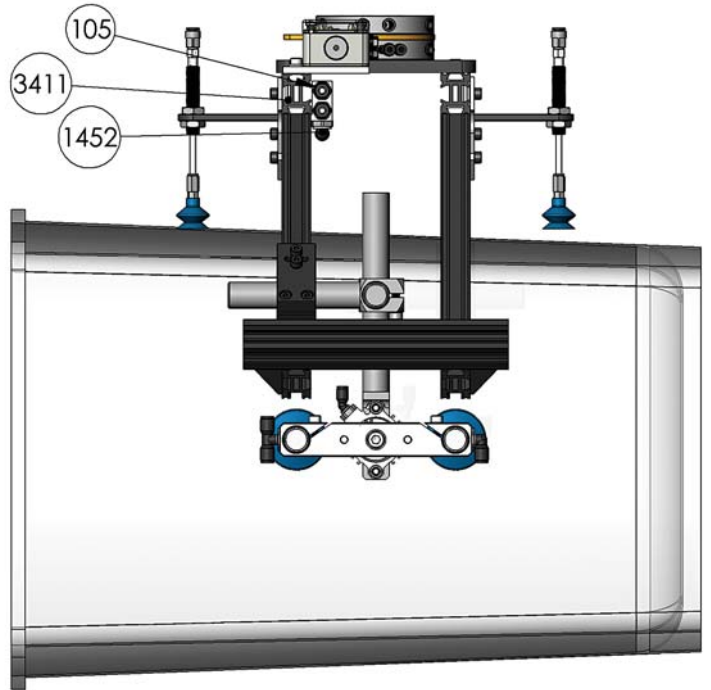
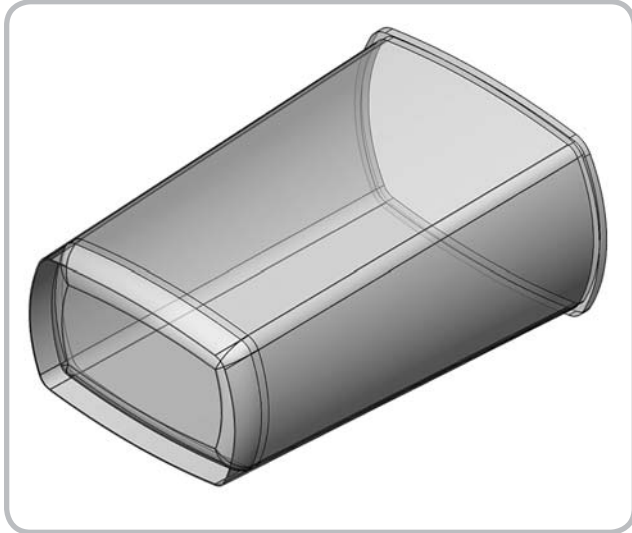

Adjustable width, deep cored part gripping using special cylinders

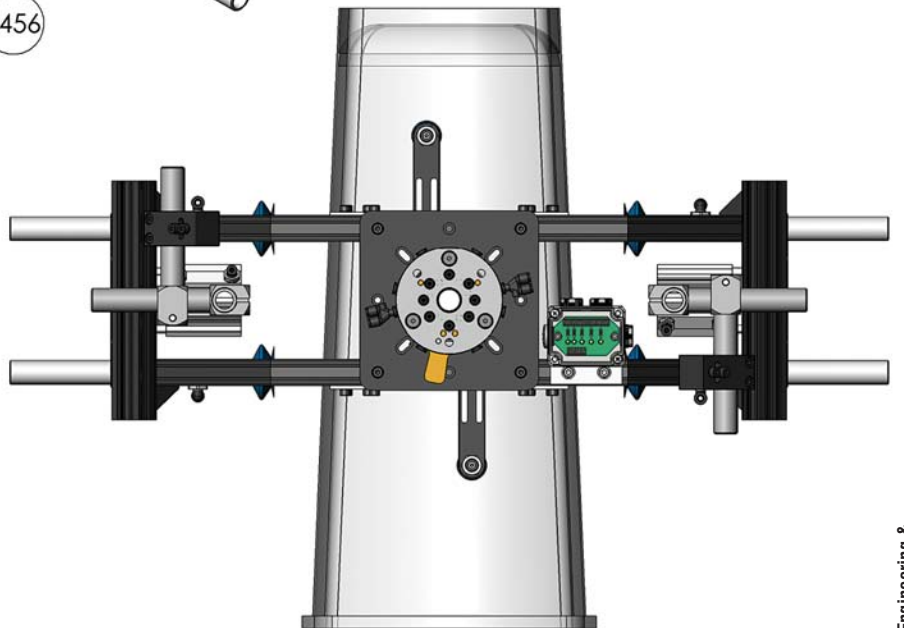
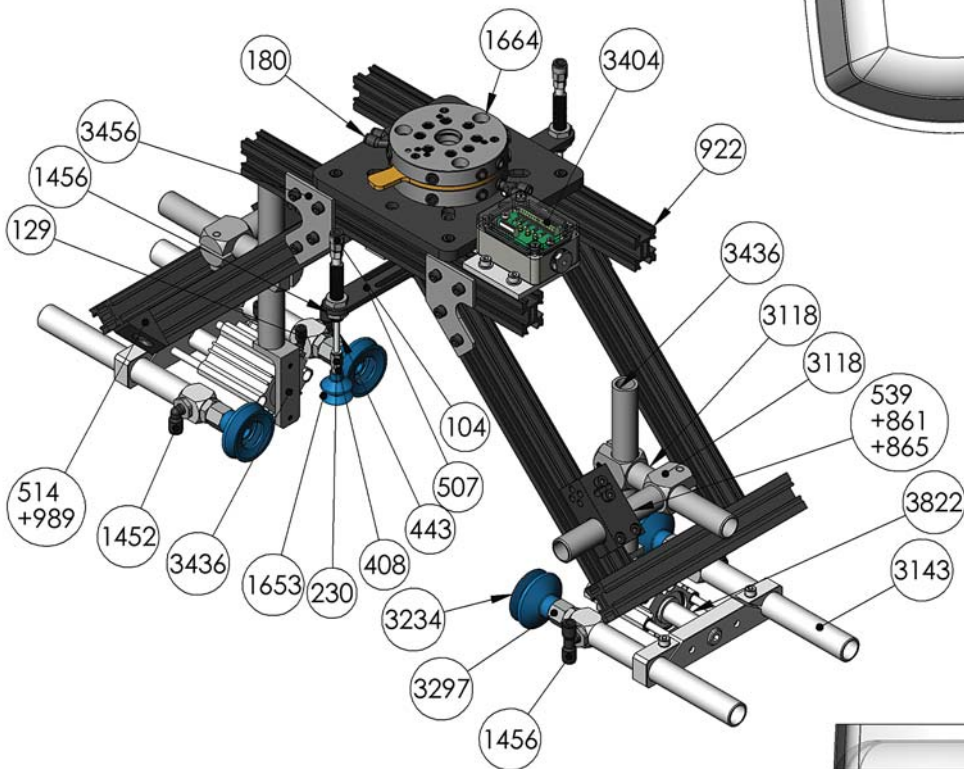
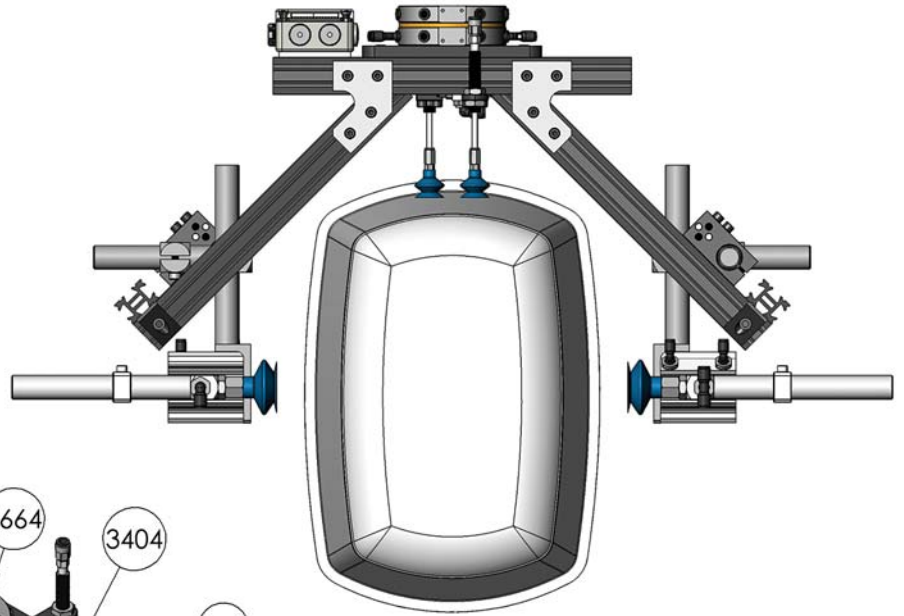

Lightweight finger grippers hold the part while degating

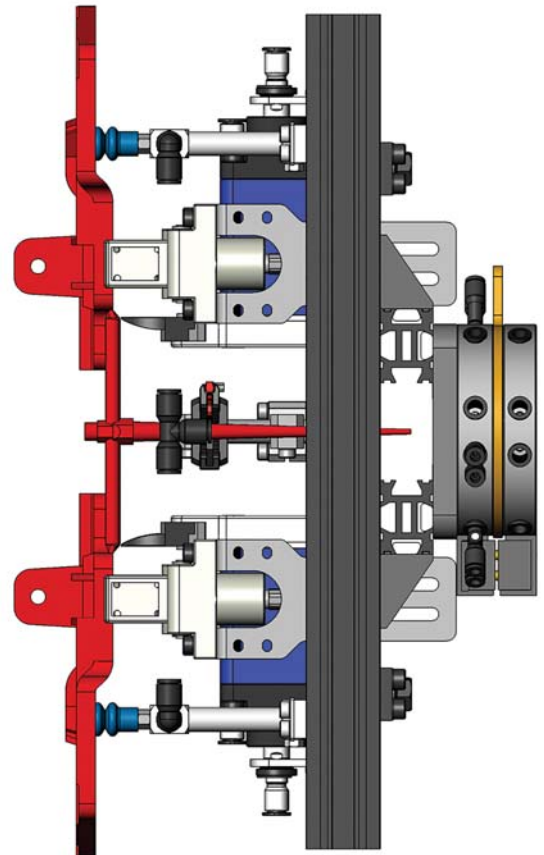
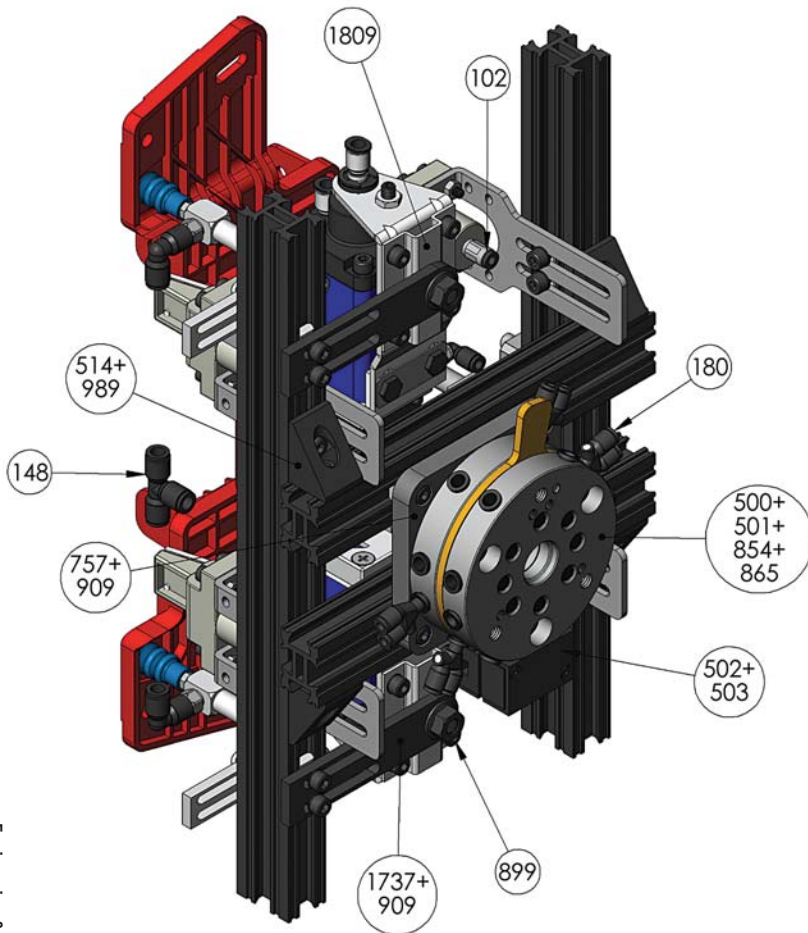
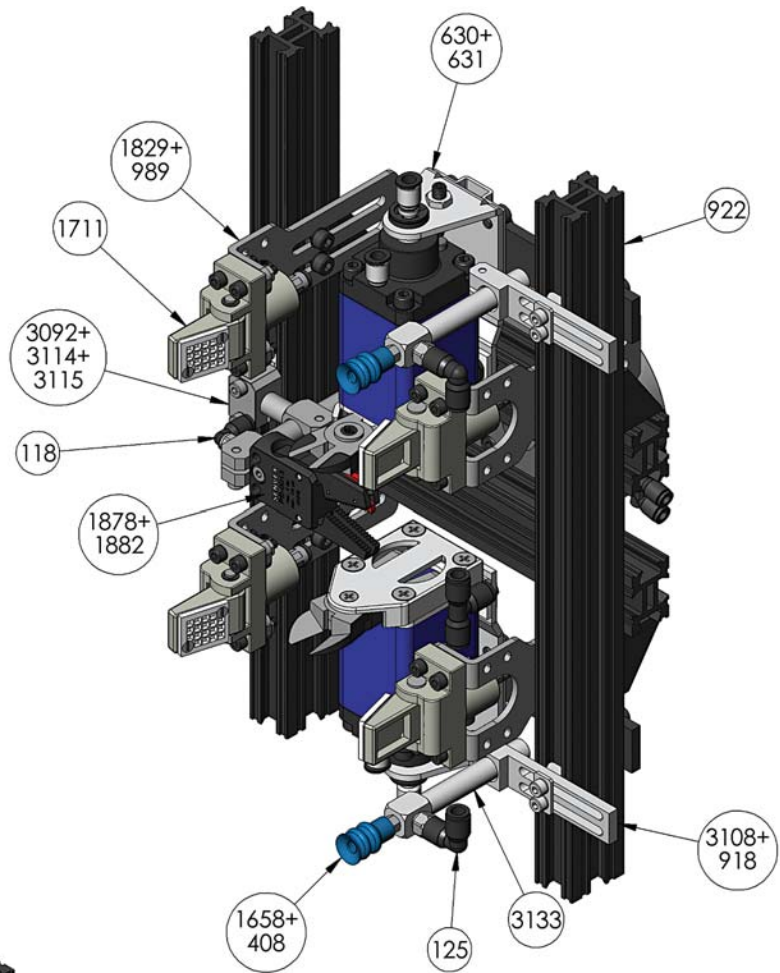
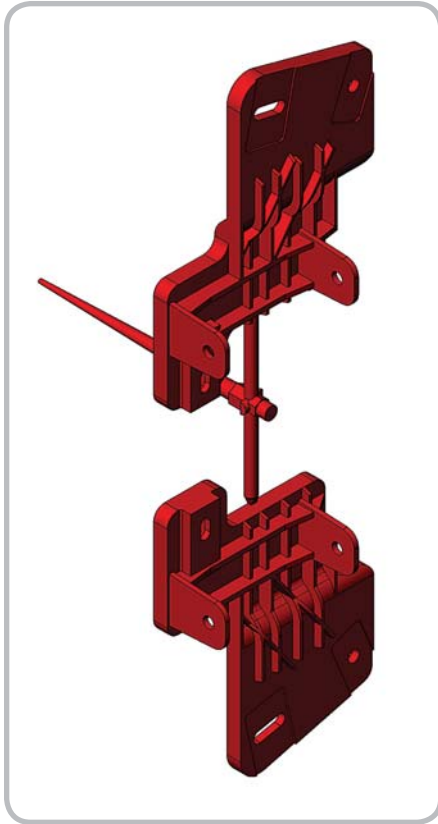

Lightweight finger grippers hold the part while degating

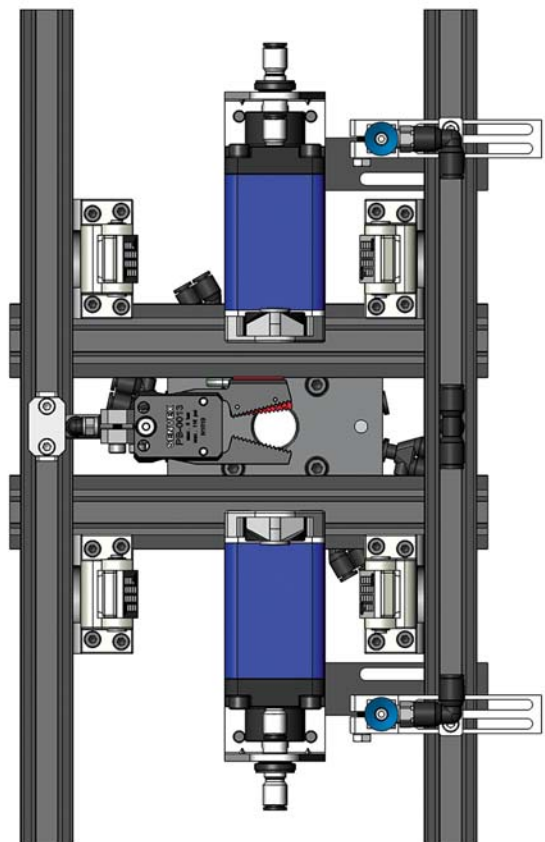
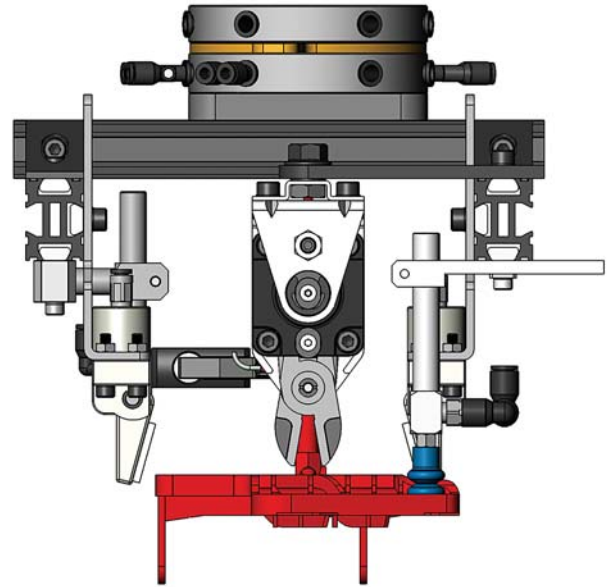
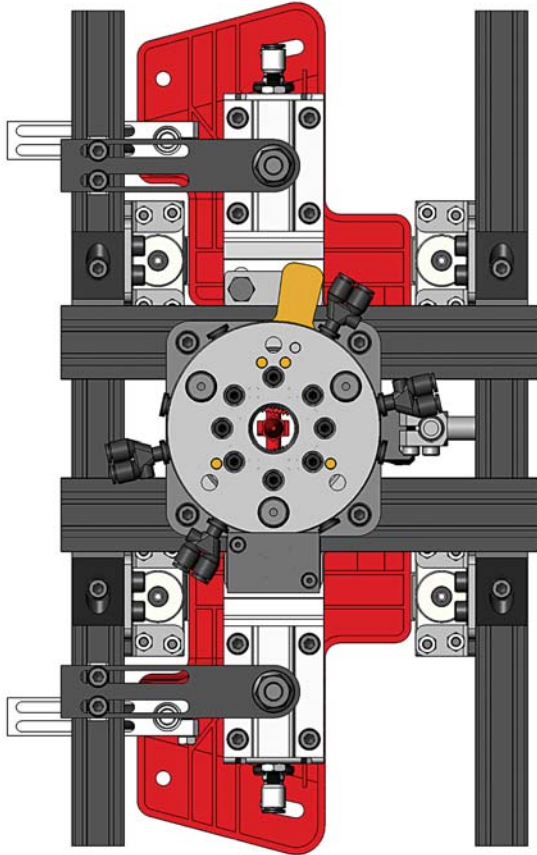

Degating with 3 nippers close together

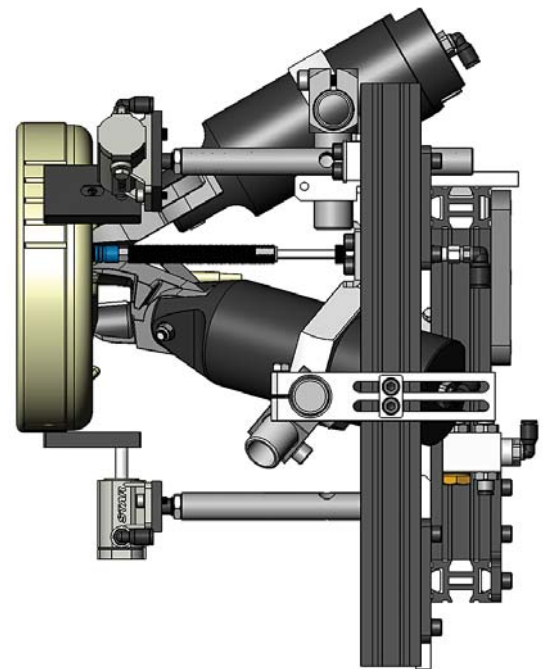
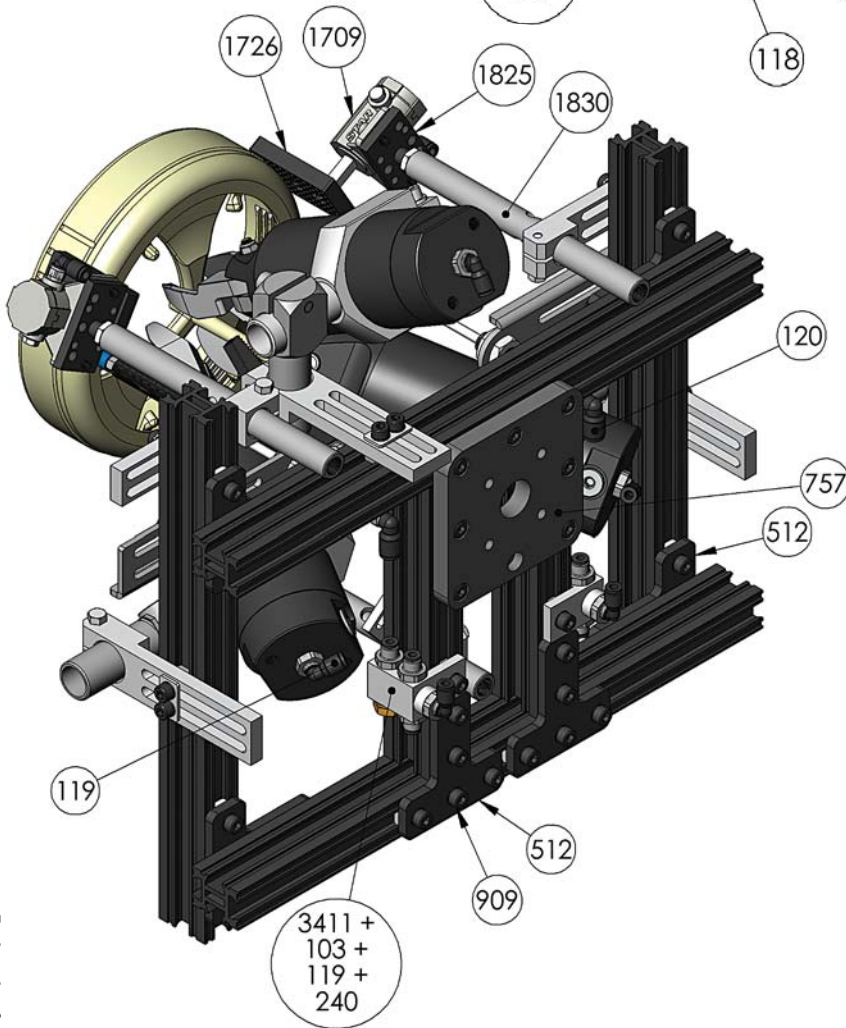
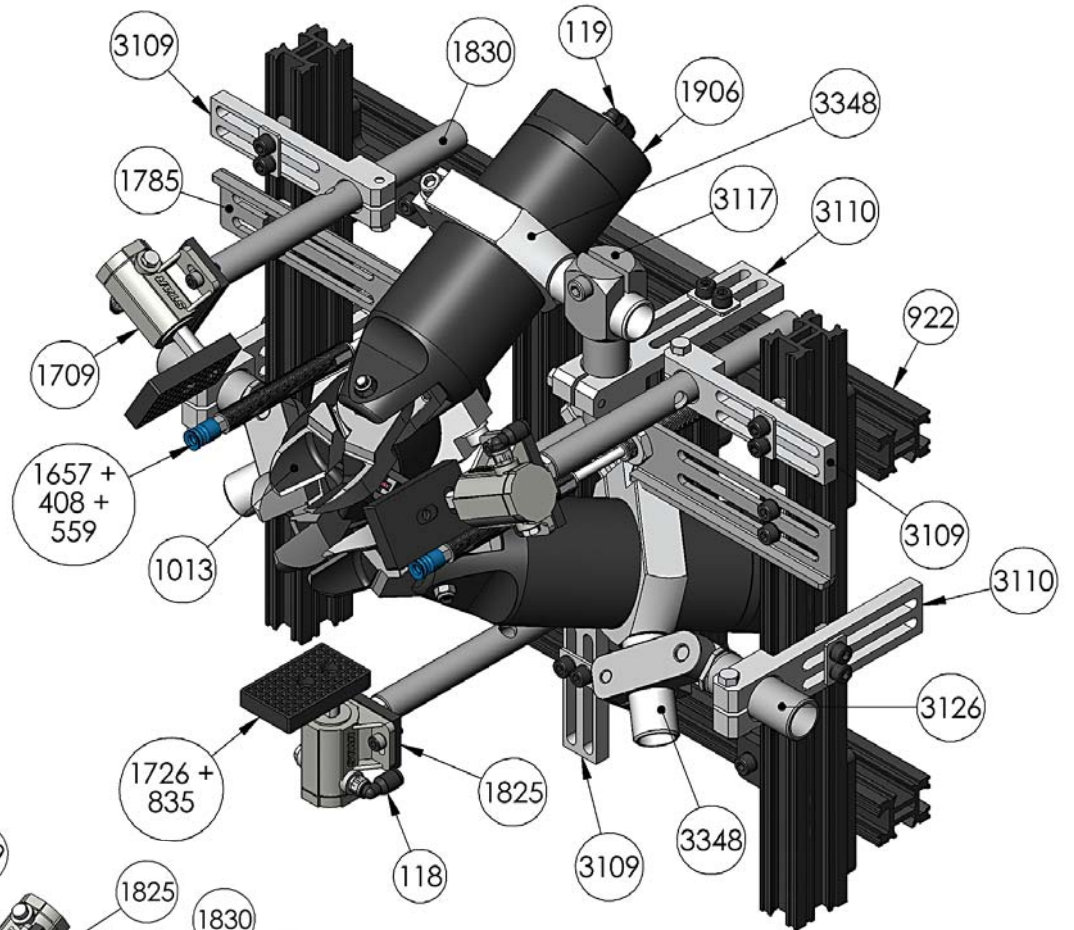
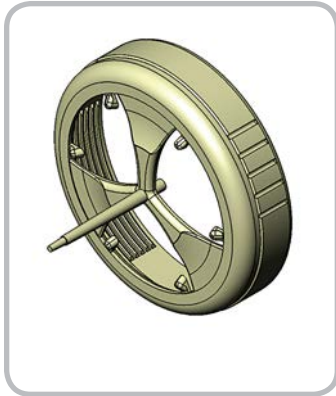

Degating with 3 nippers close together

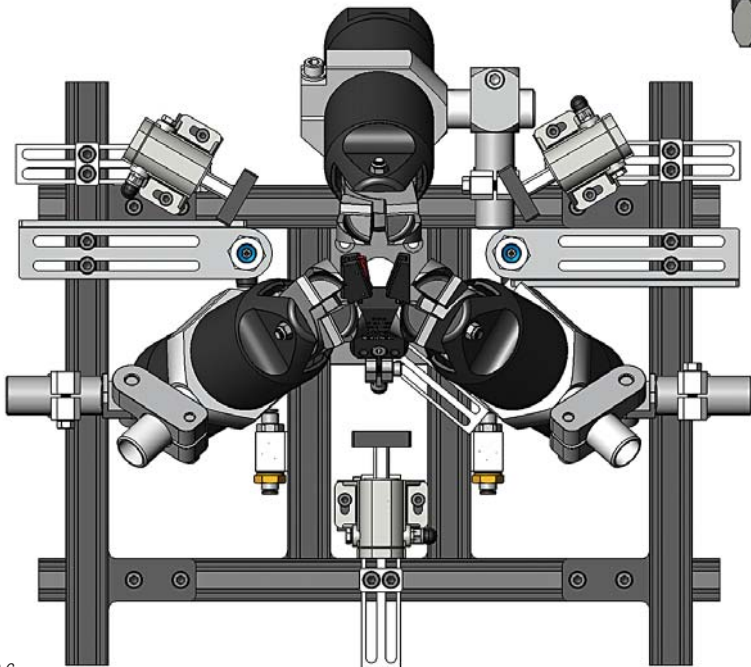
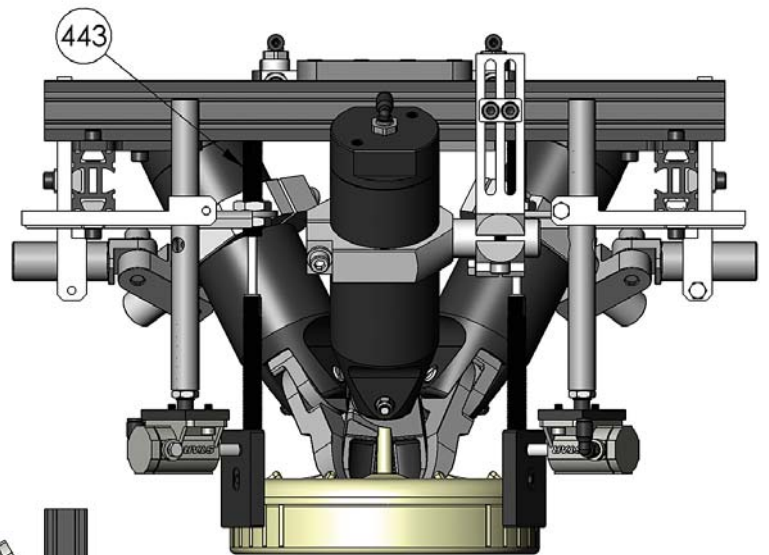
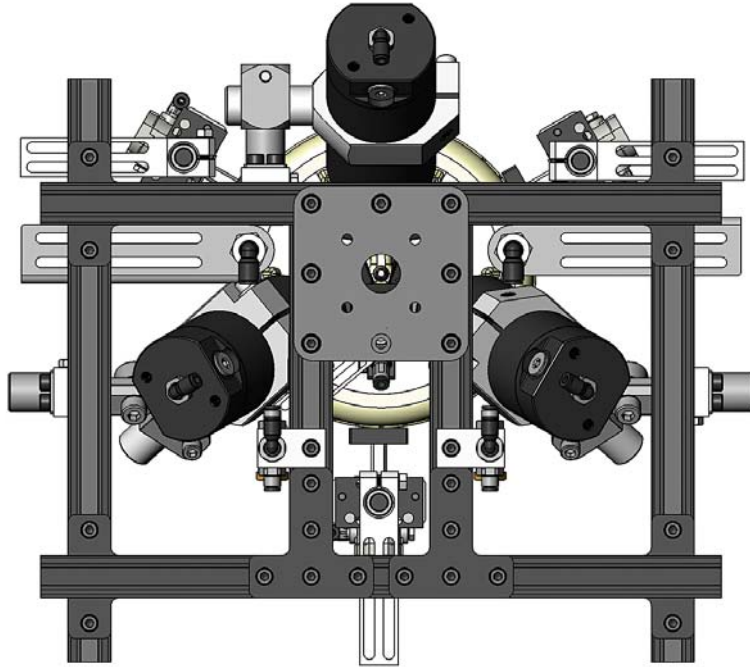

Finger grippers on linear slides to move part over in-mold lifters

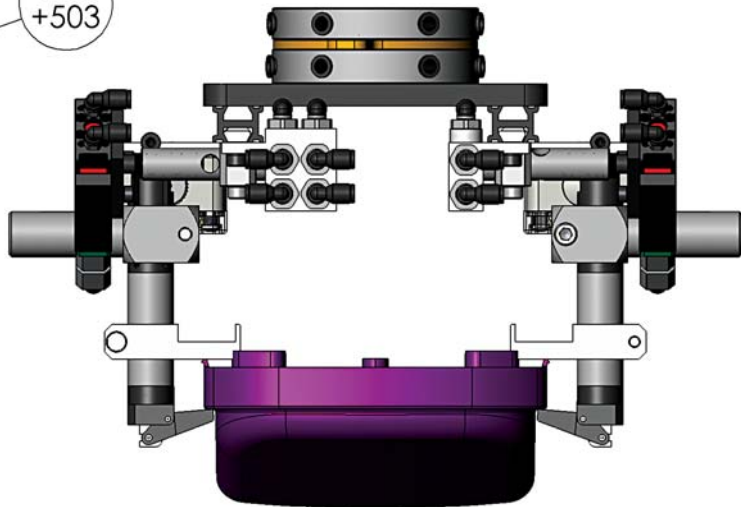
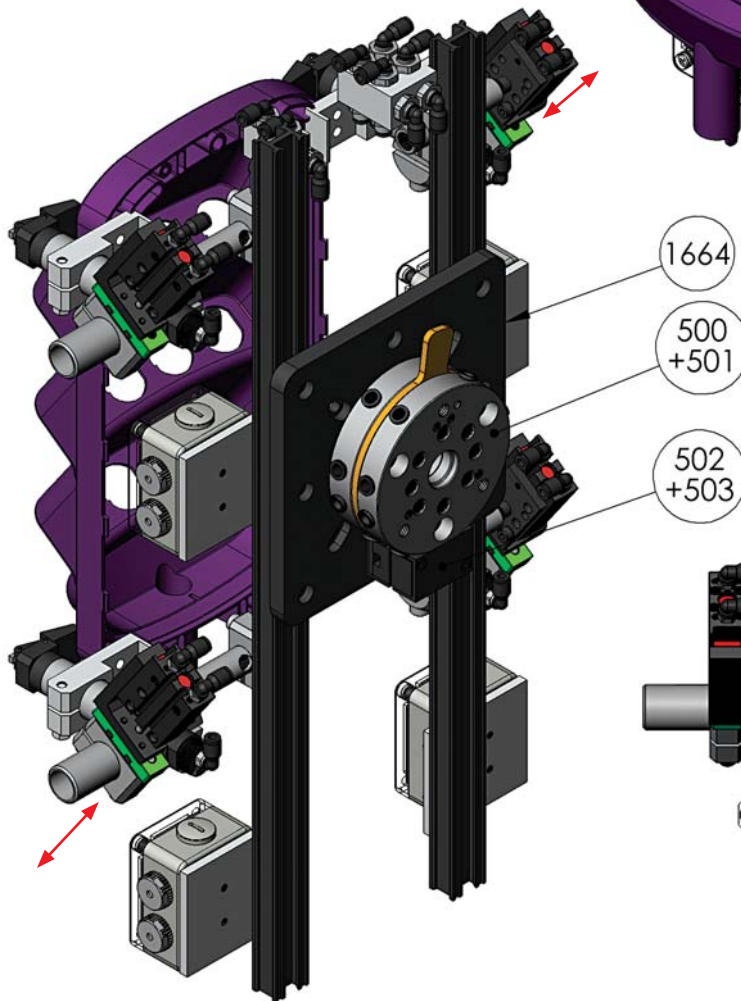
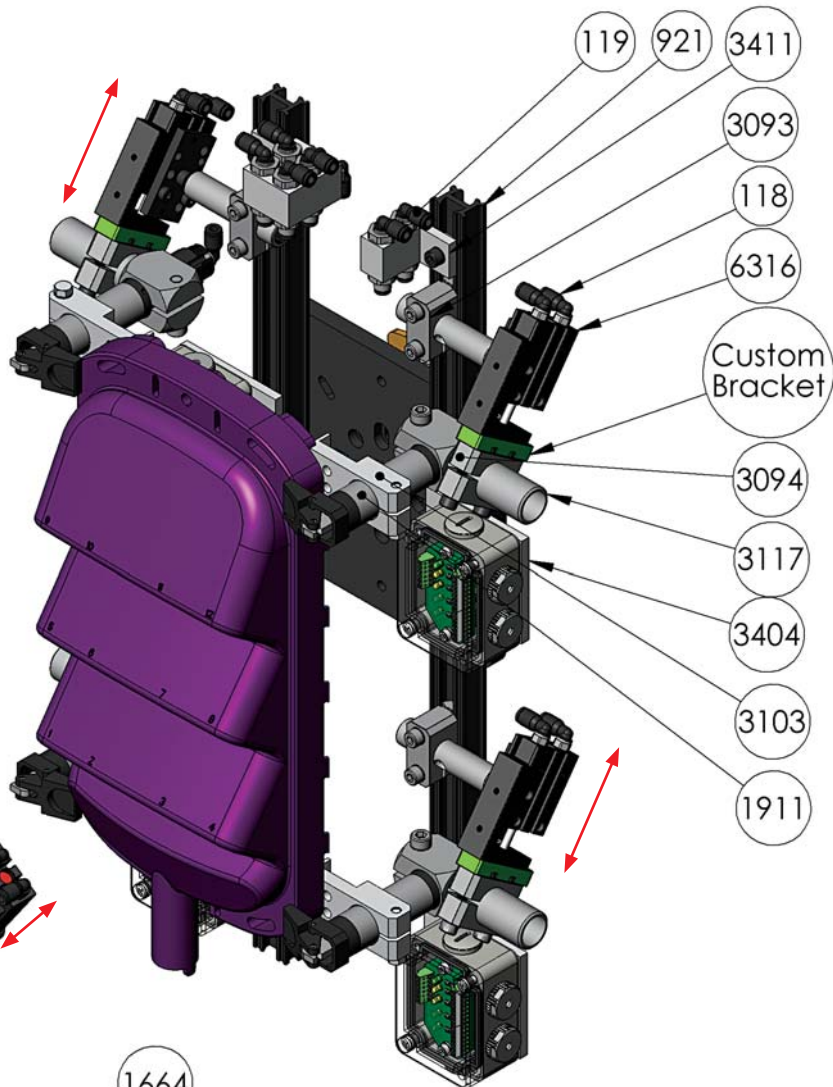

Finger grippers on linear slides to move part over in-mold lifters

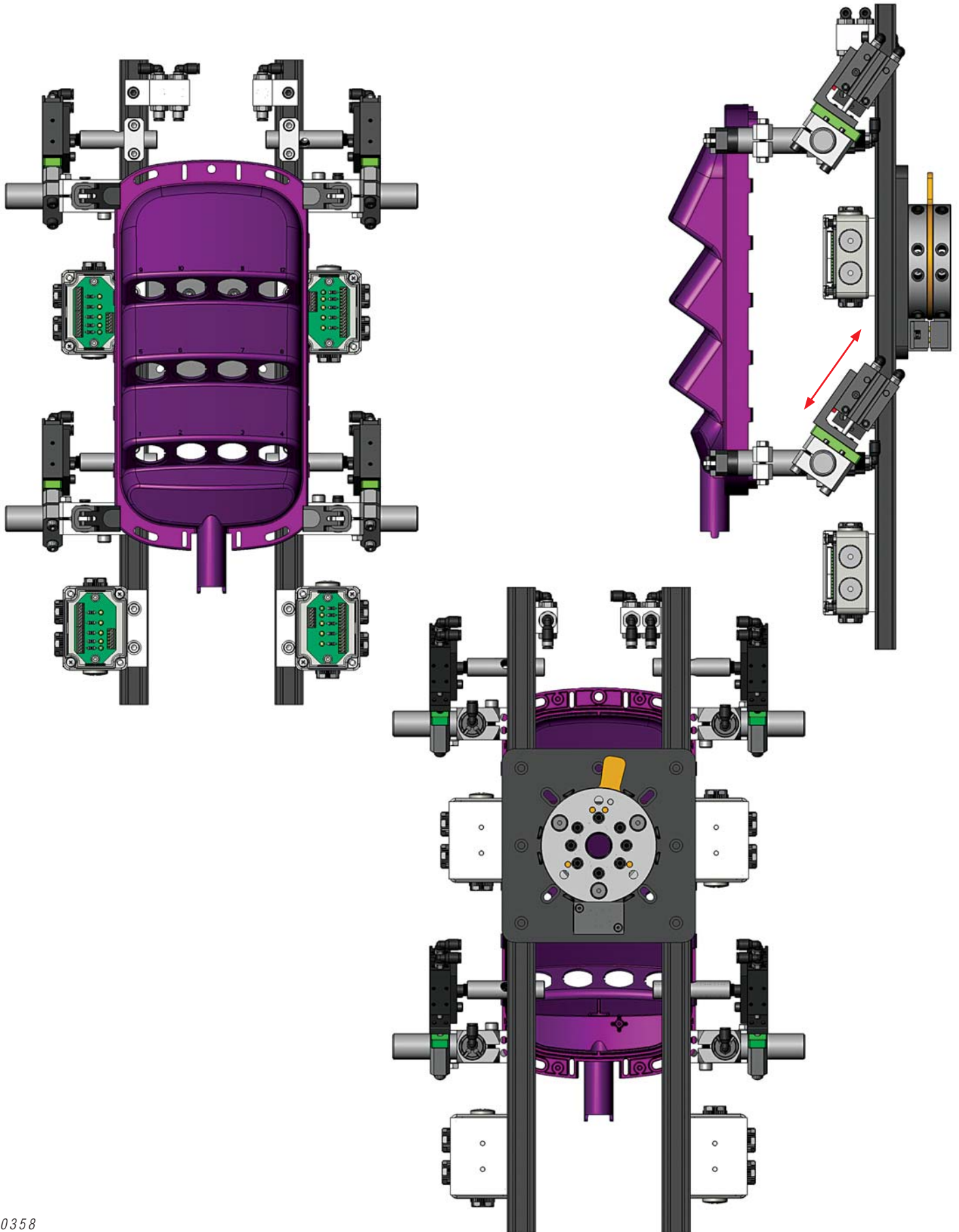

2 rotary actuators used together to rotate live hinge +90° & -90°

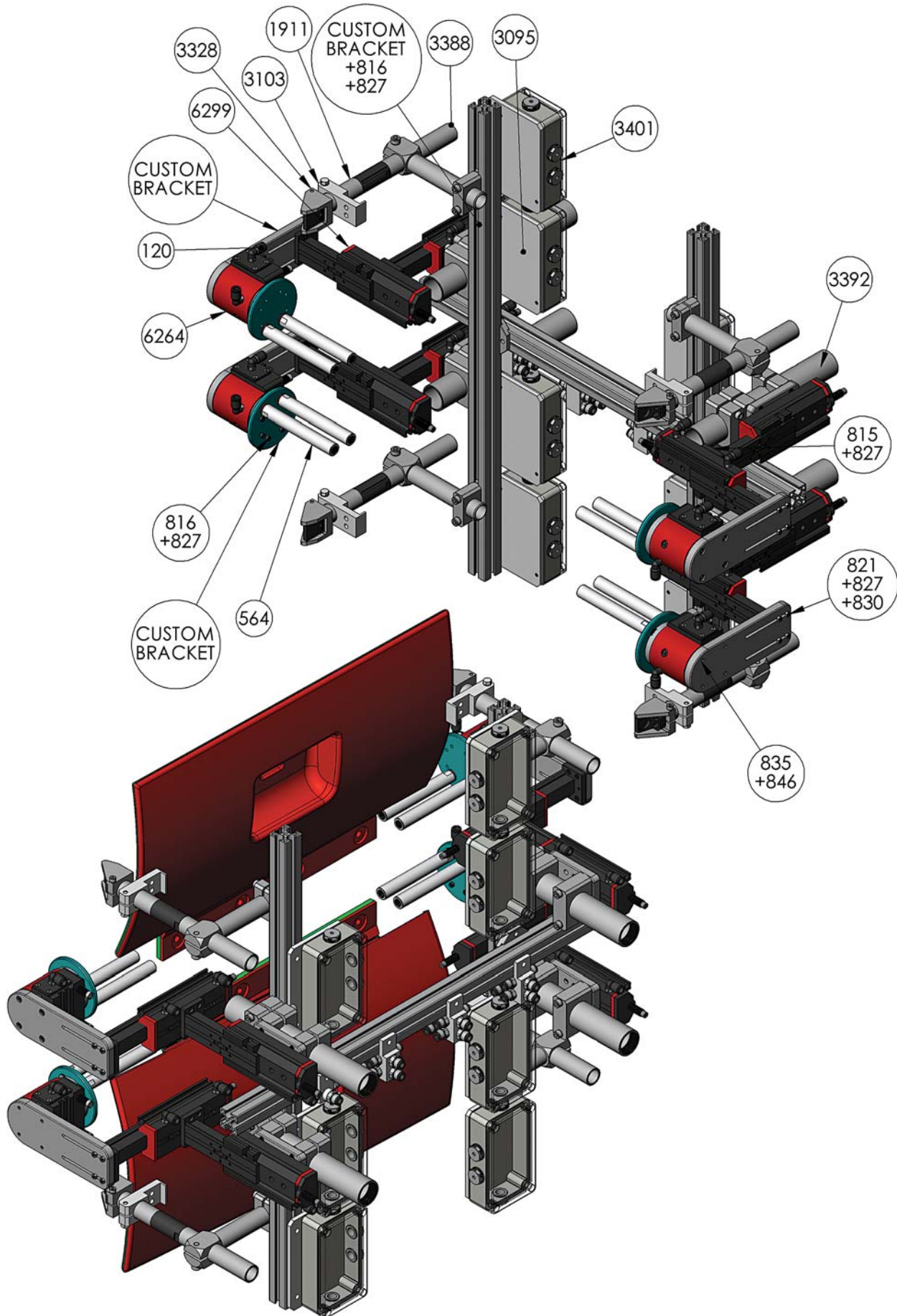

2 rotary actuators used together to rotate live hinge +90° & -90°

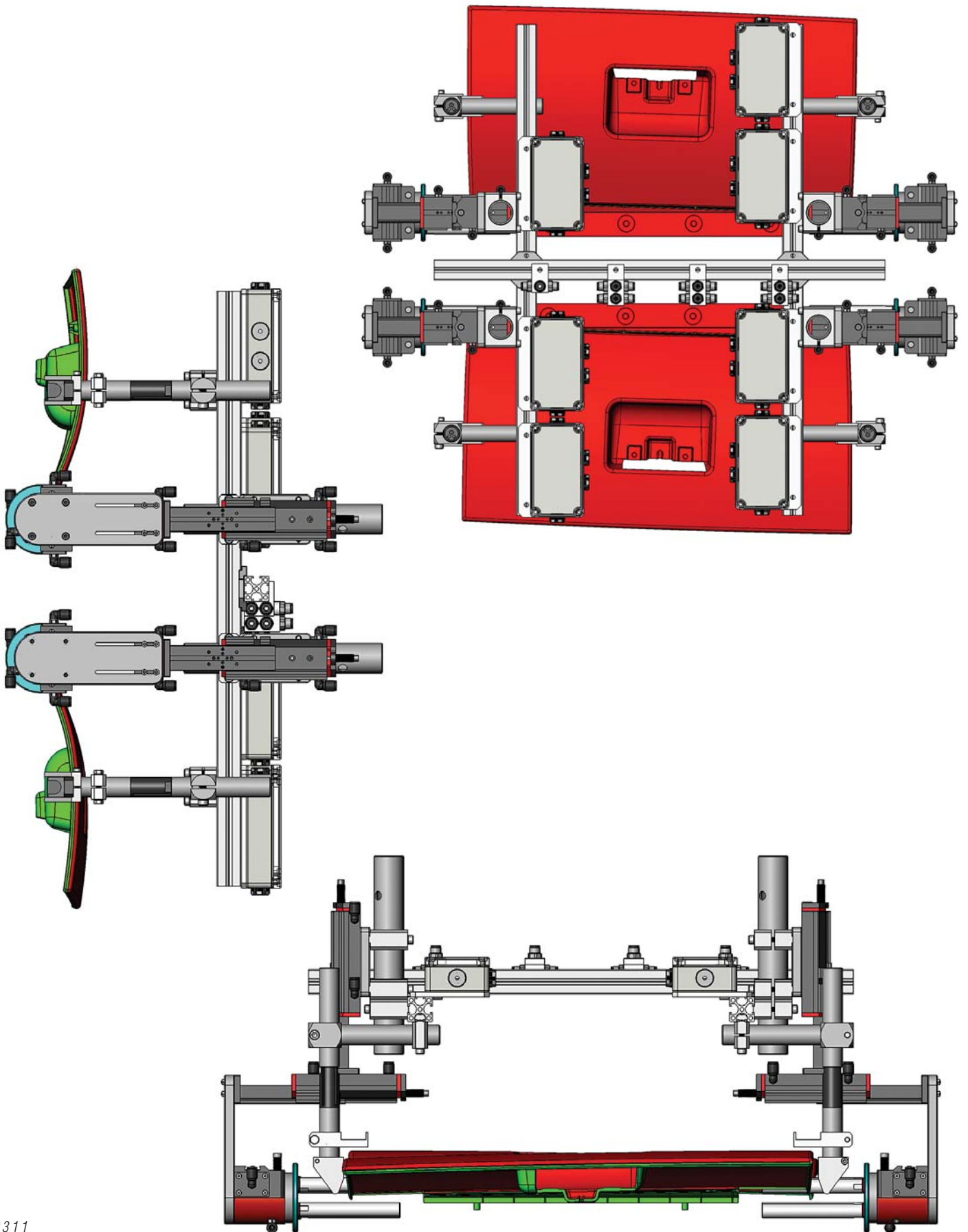

Insert loading

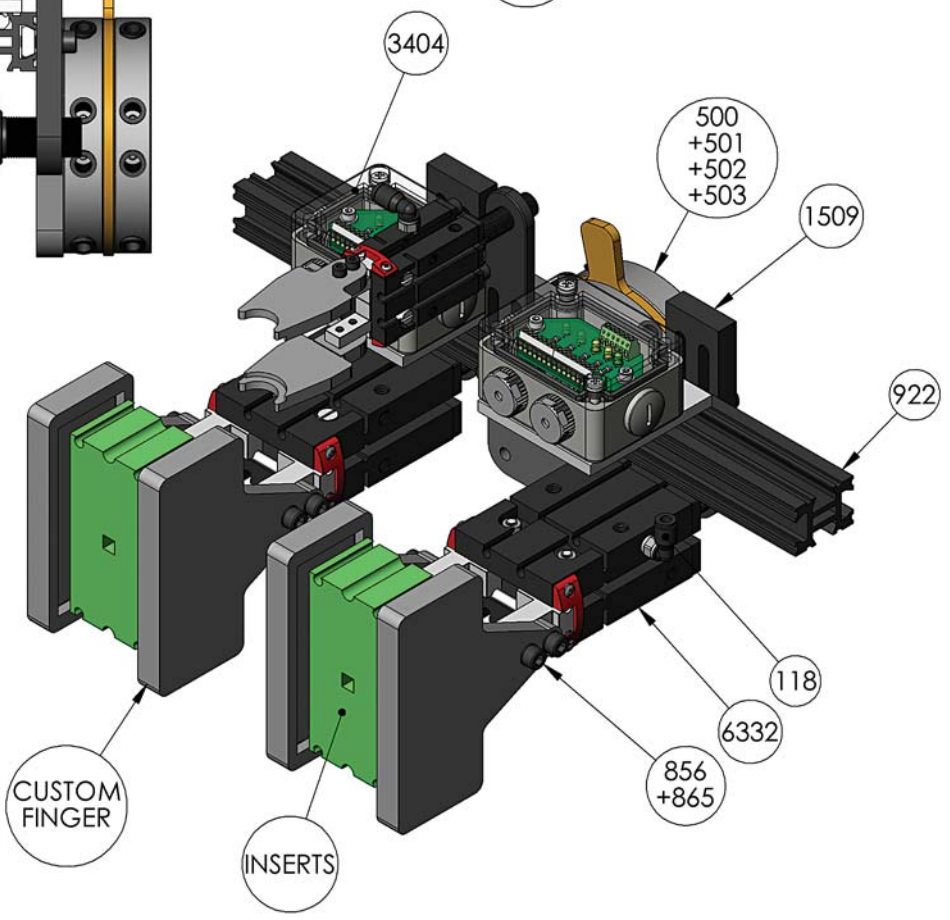
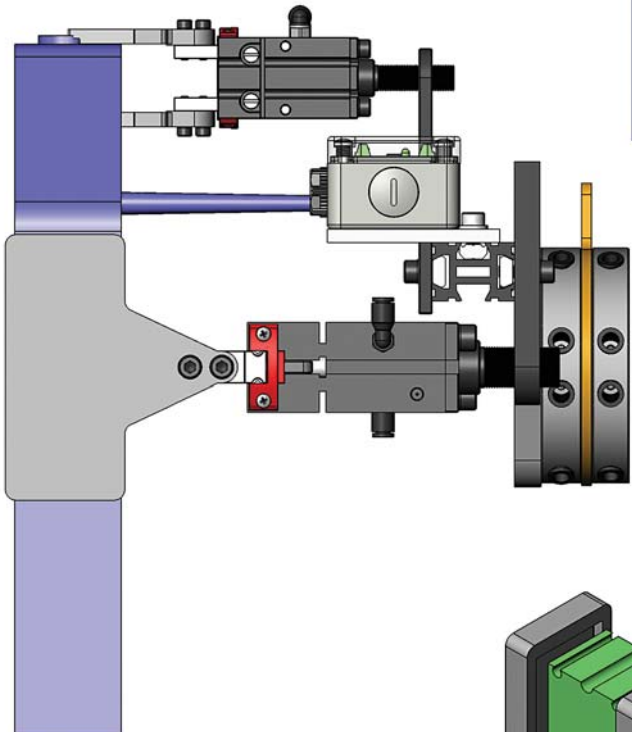
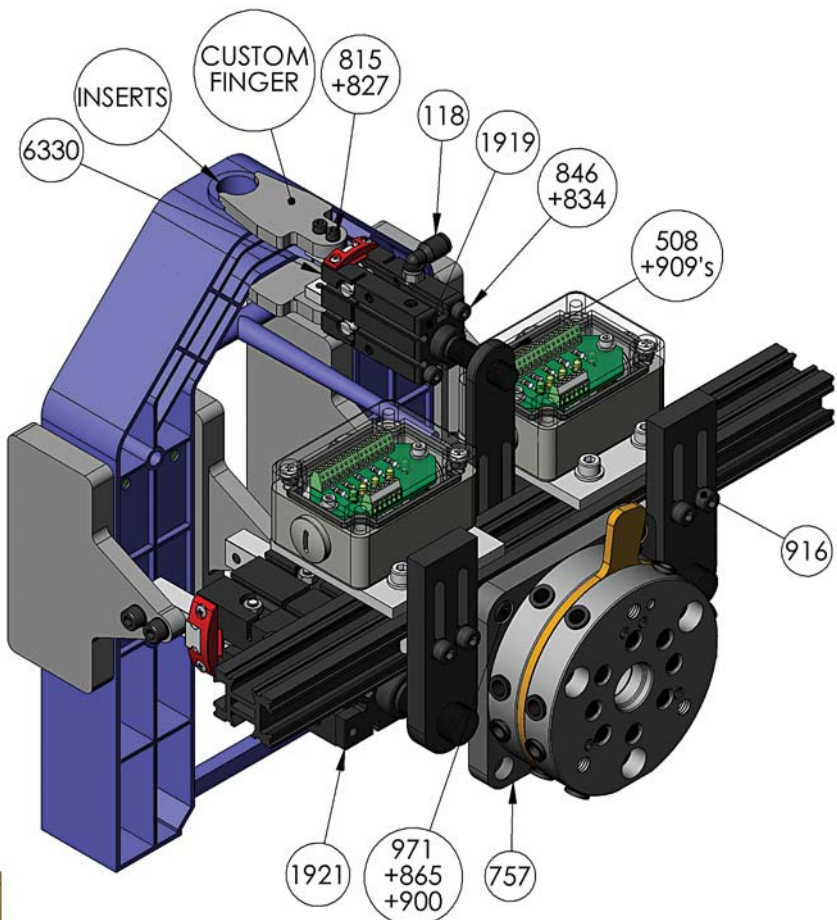
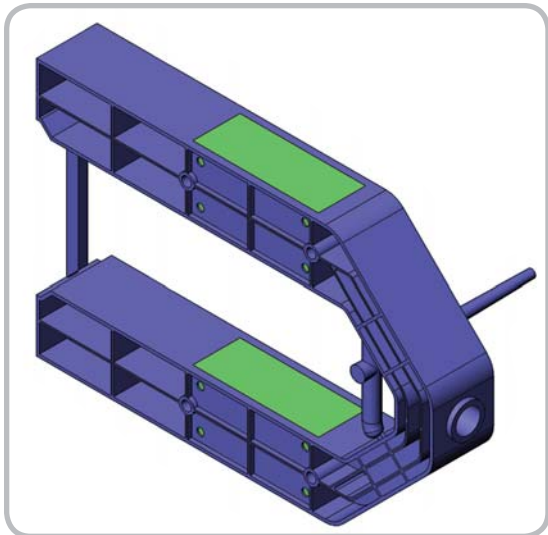

Insert loading

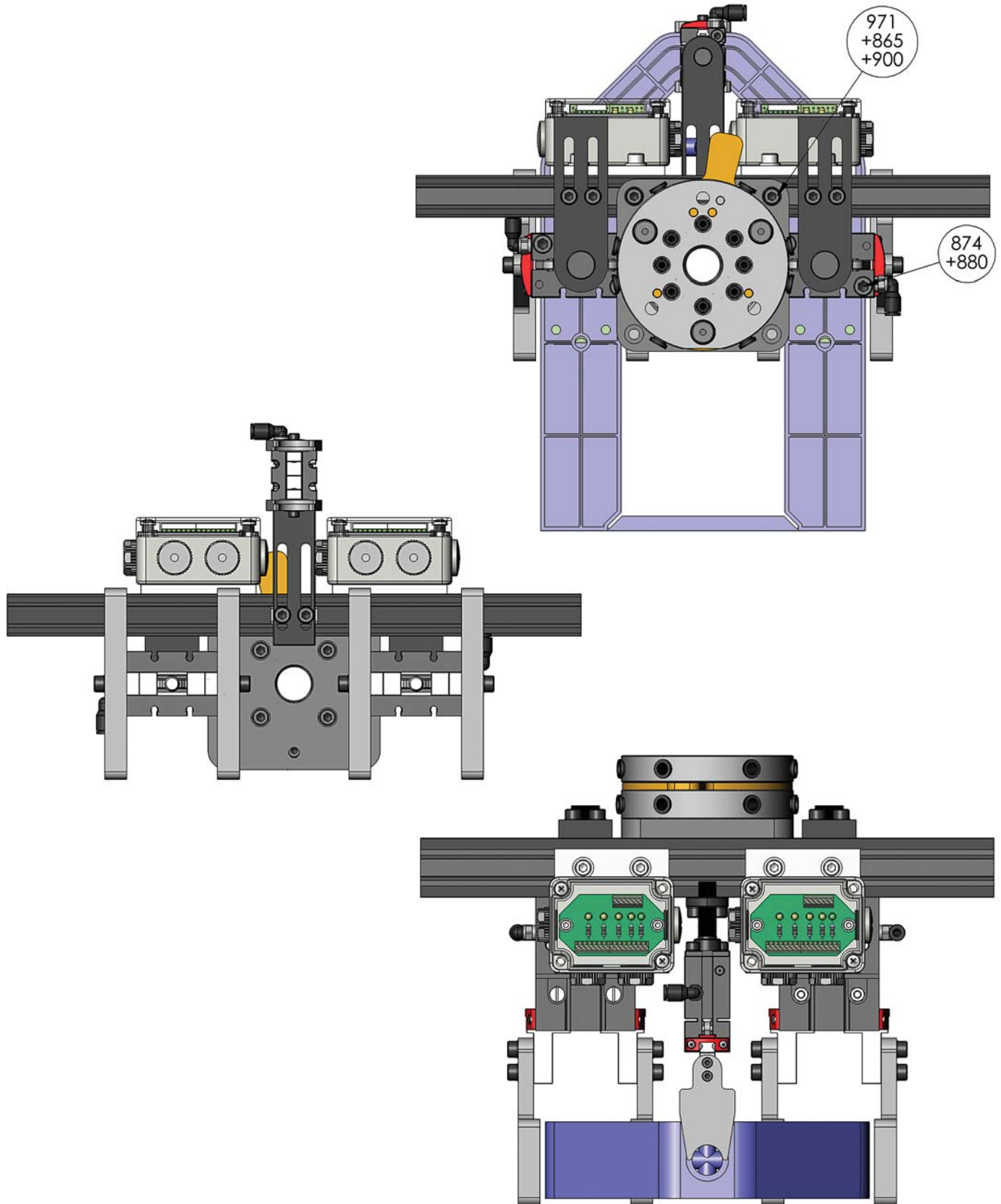

Part verification using photoeyes to sense translucent parts

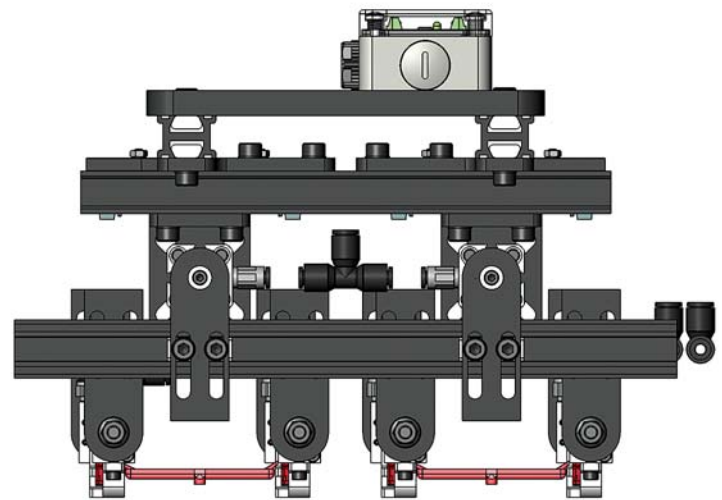
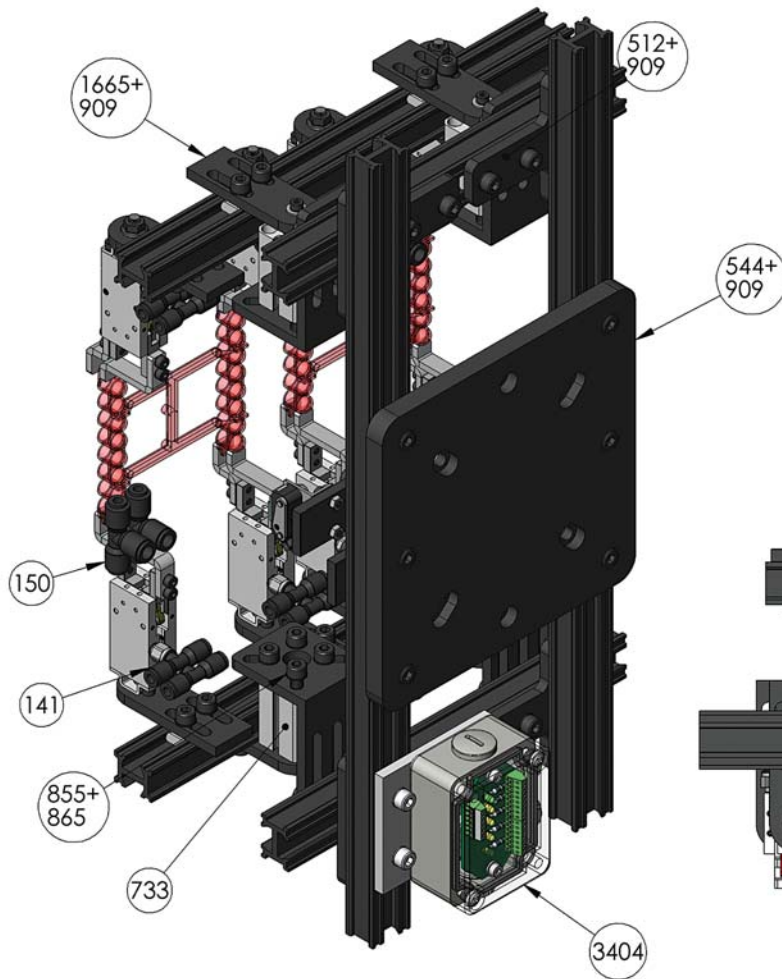
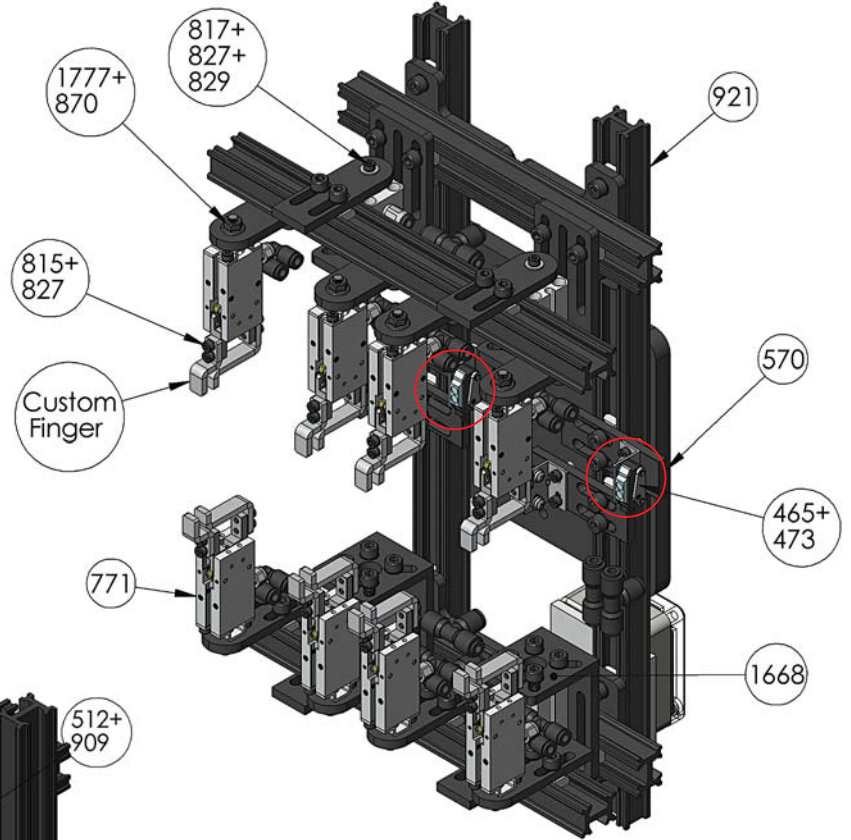
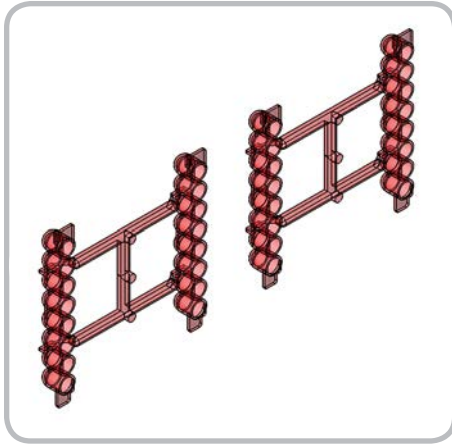

Part verification using photoeyes to sense translucent parts

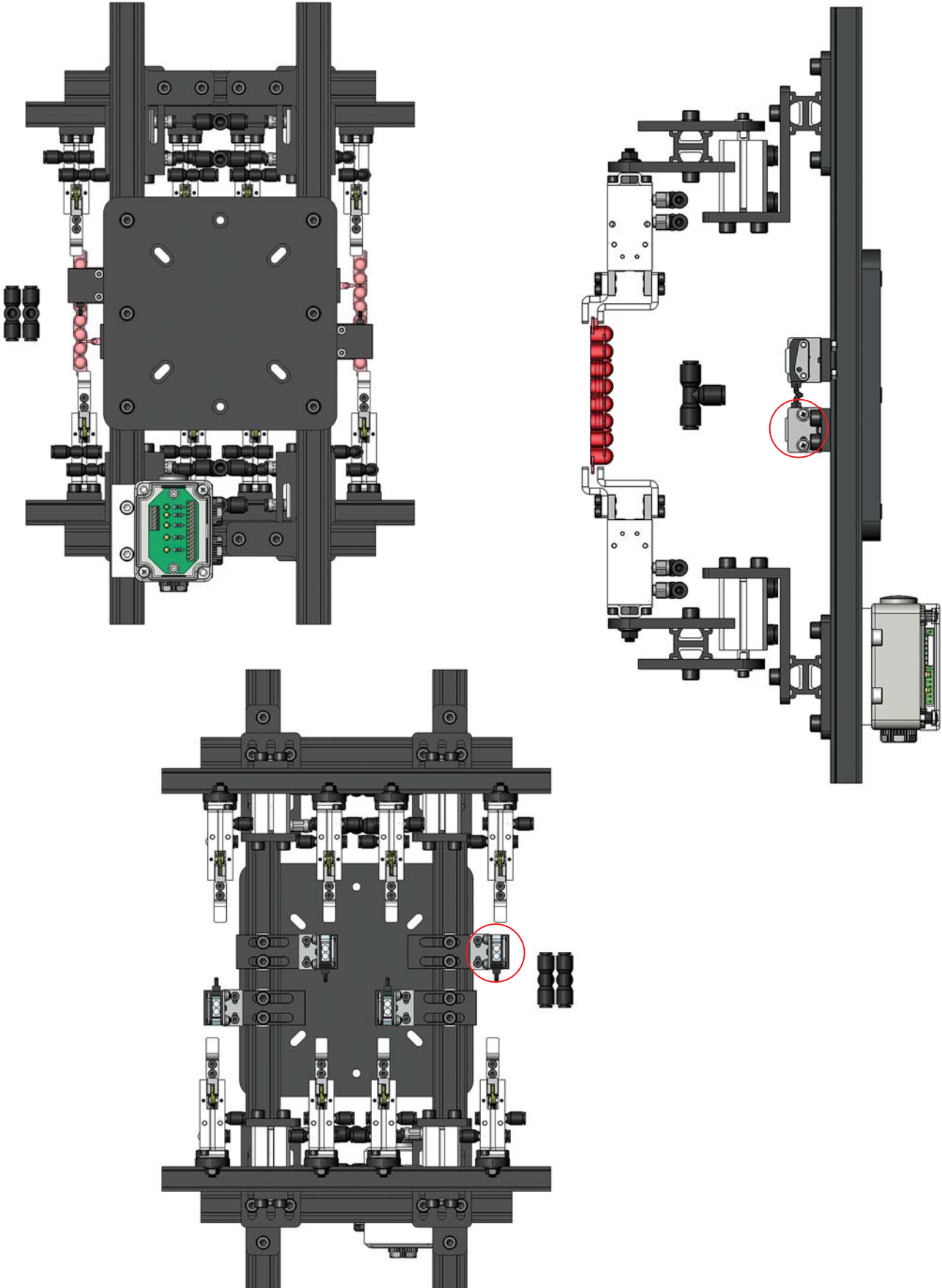

Degating station with 1 heavy-duty slide to position 8 nippers

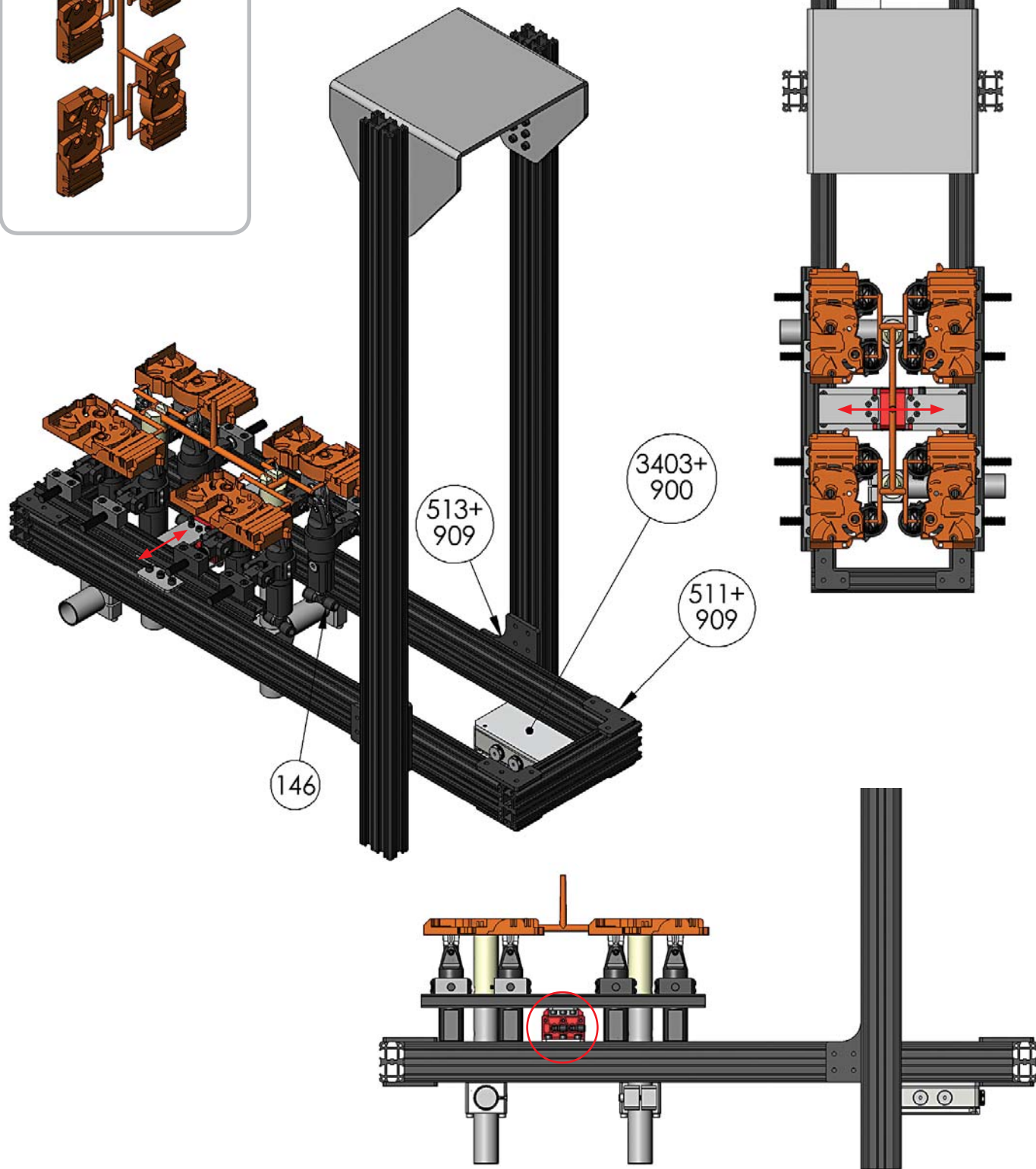
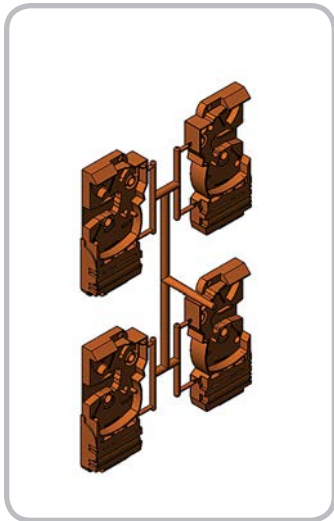

Degating station with 1 heavy-duty slide to position 8 nippers

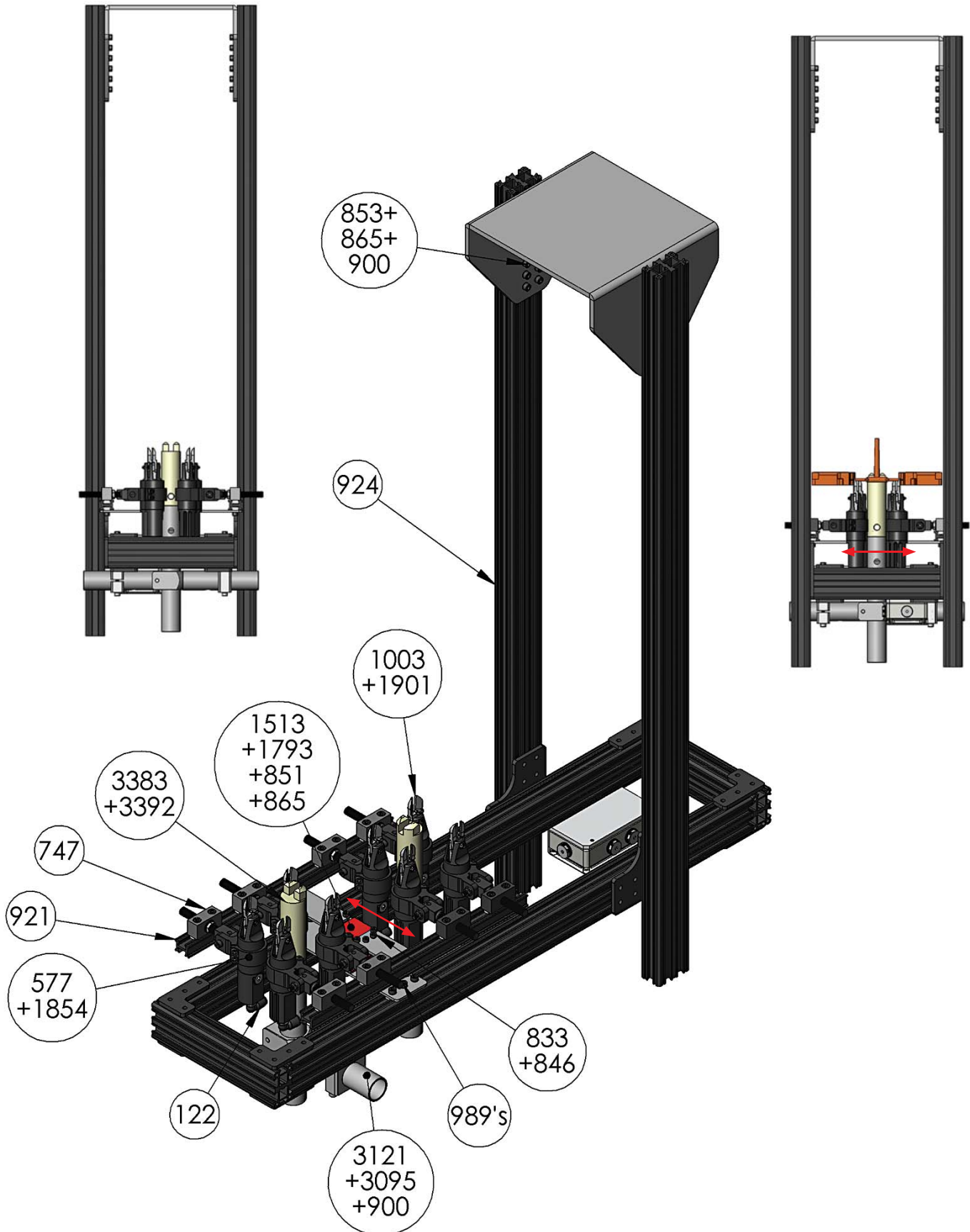

O.D. Air Hands

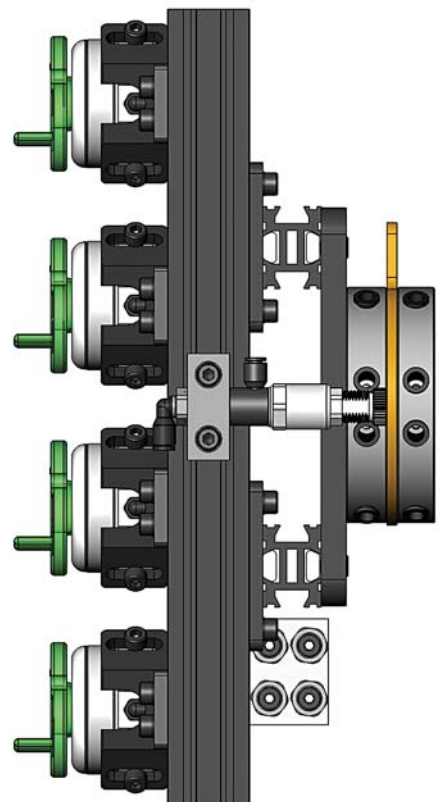
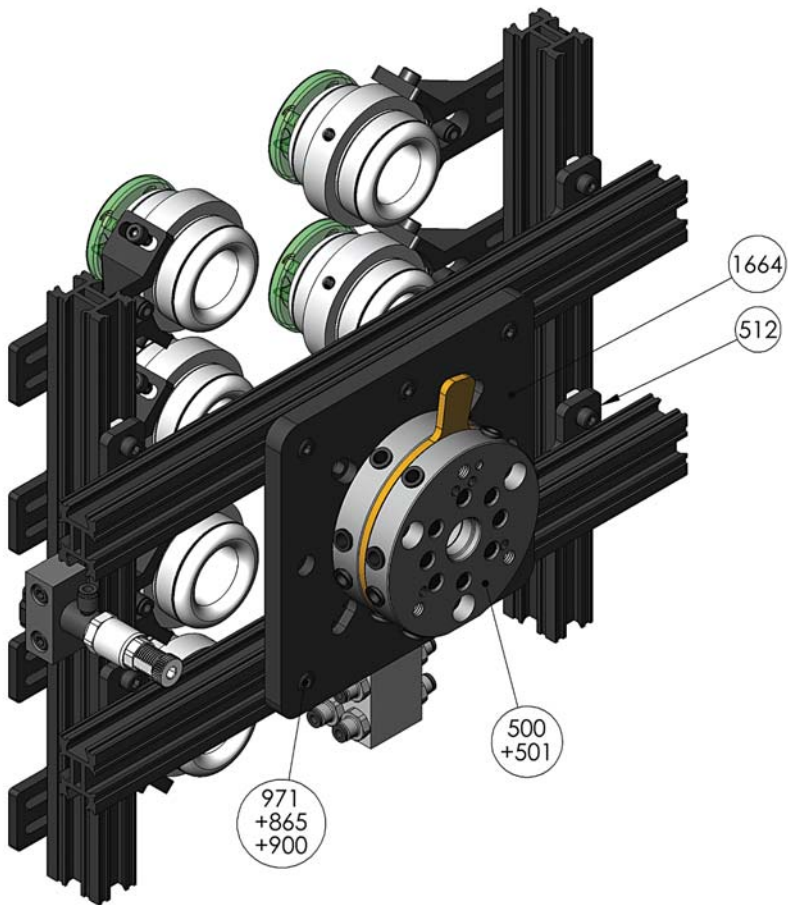
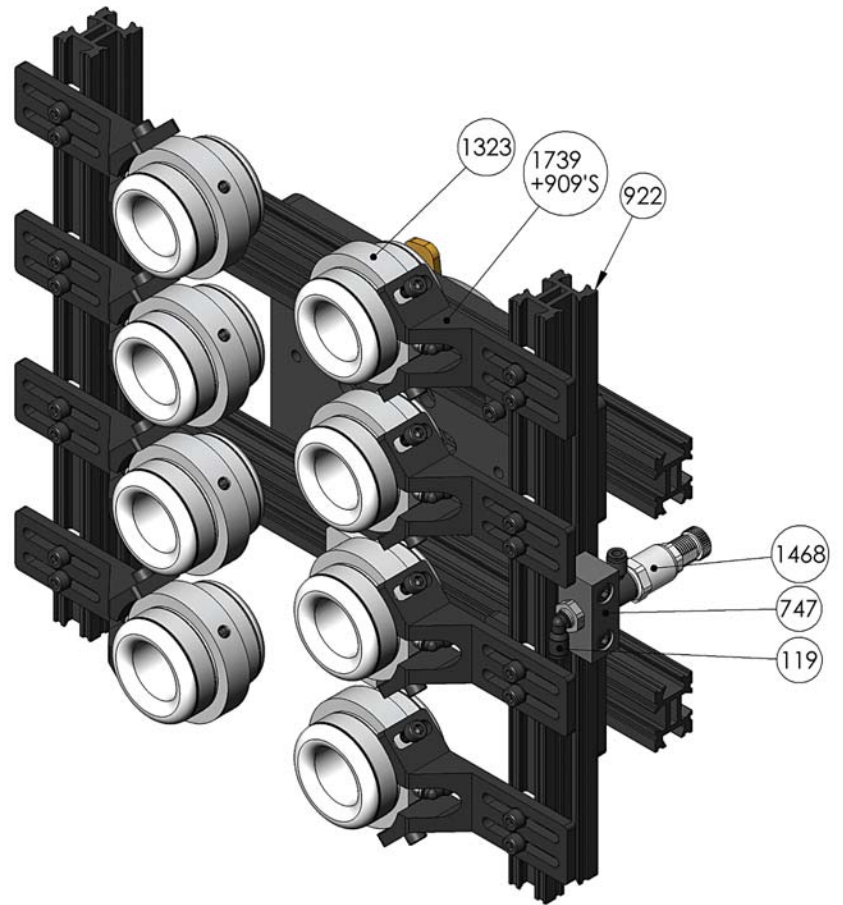
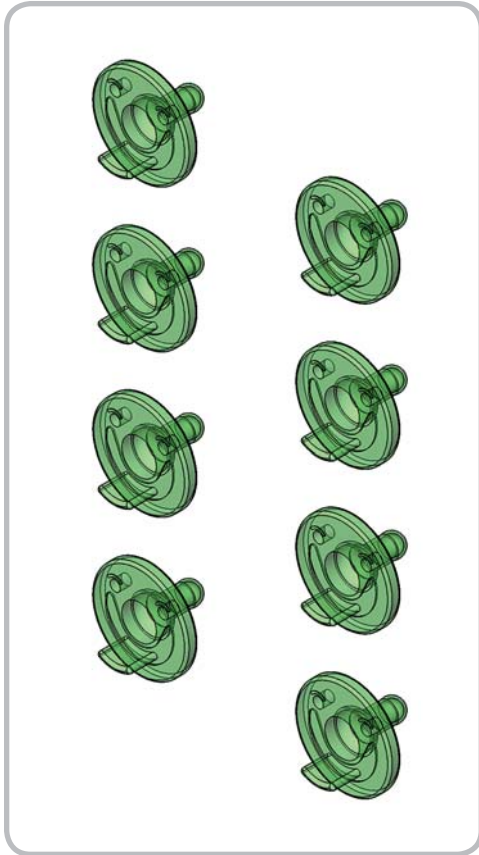

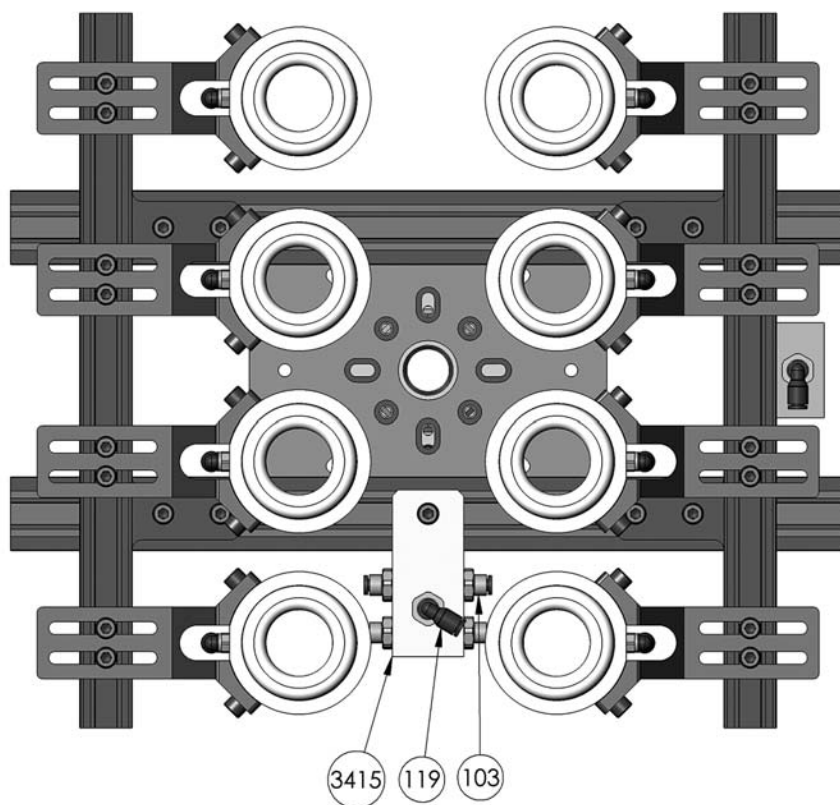
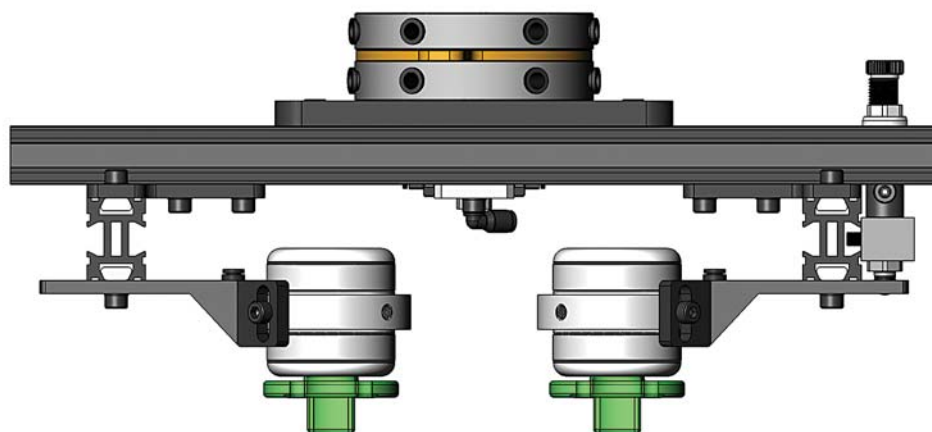

Gripper fingers mounted on linear slides to strip part ends off of mold

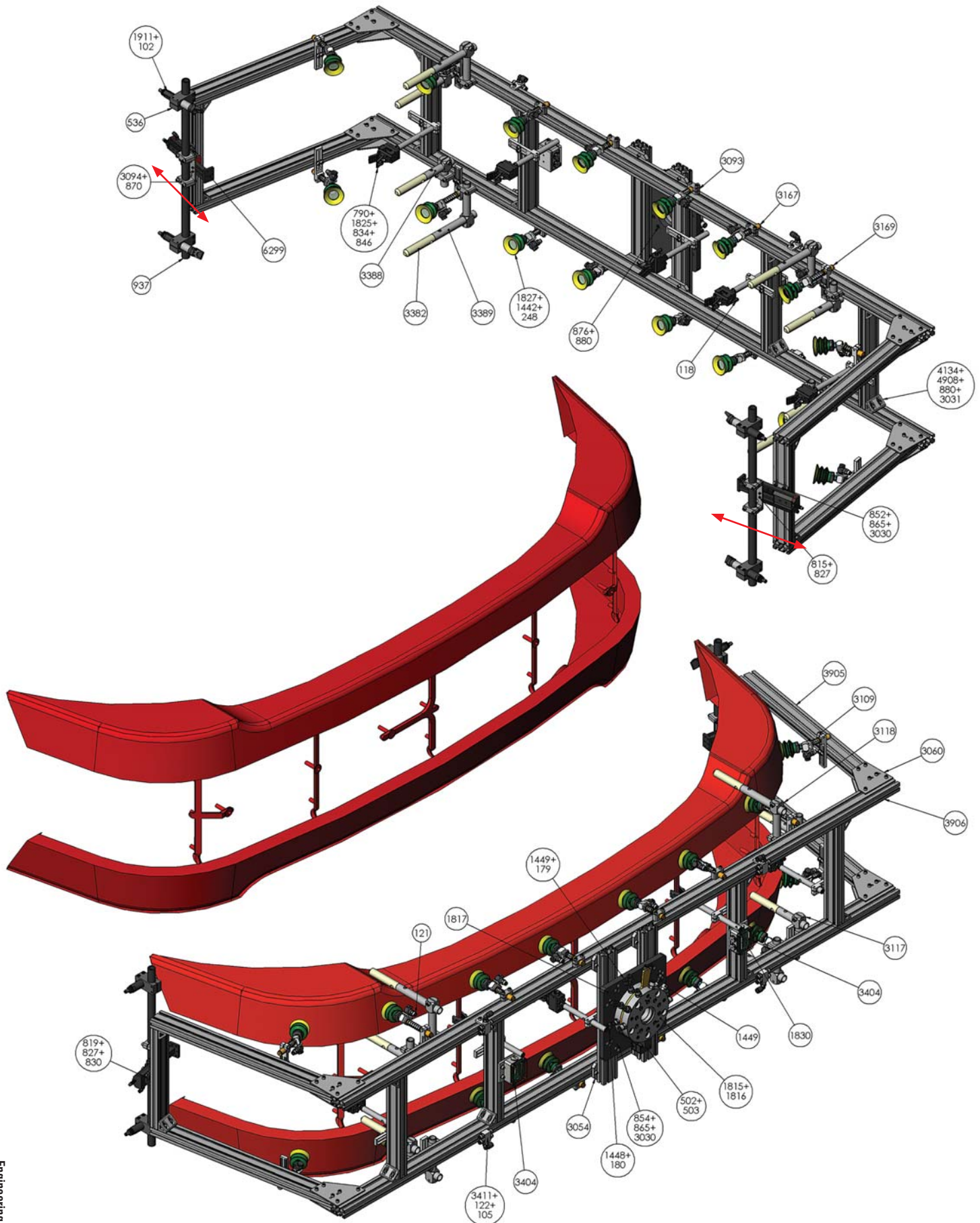

Gripper fingers mounted on linear slides to strip part ends off of mold

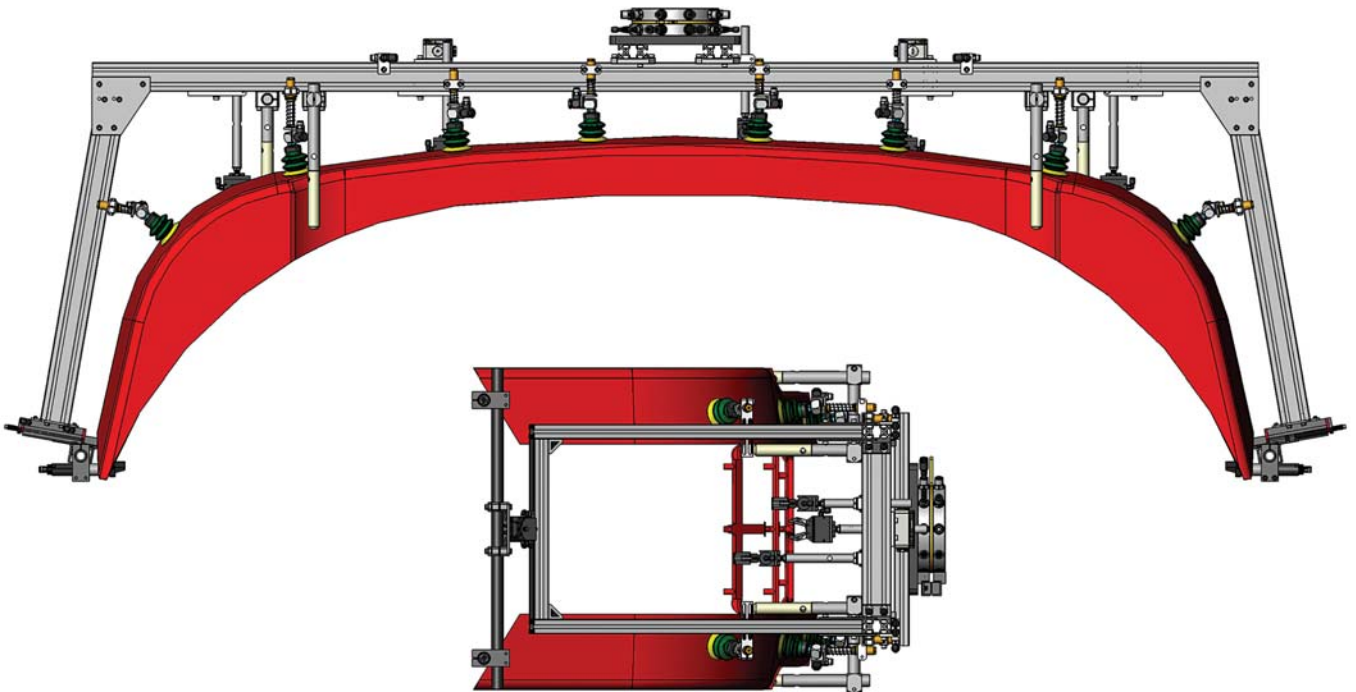
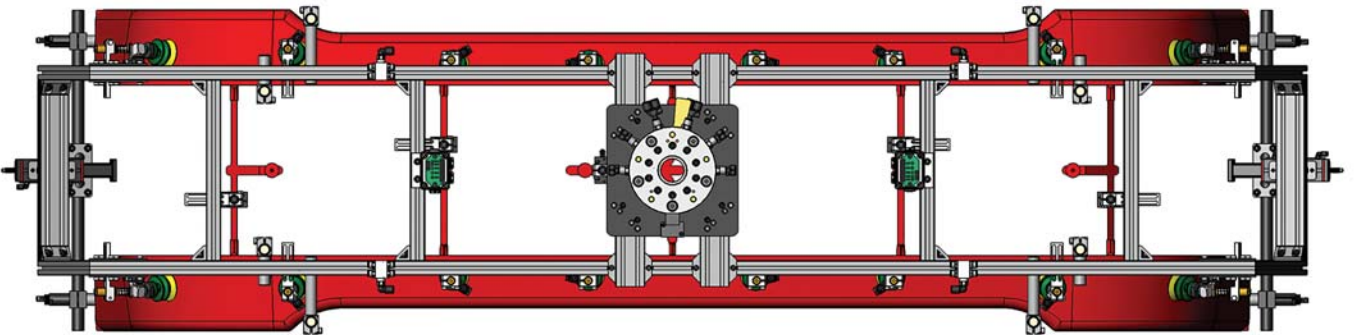
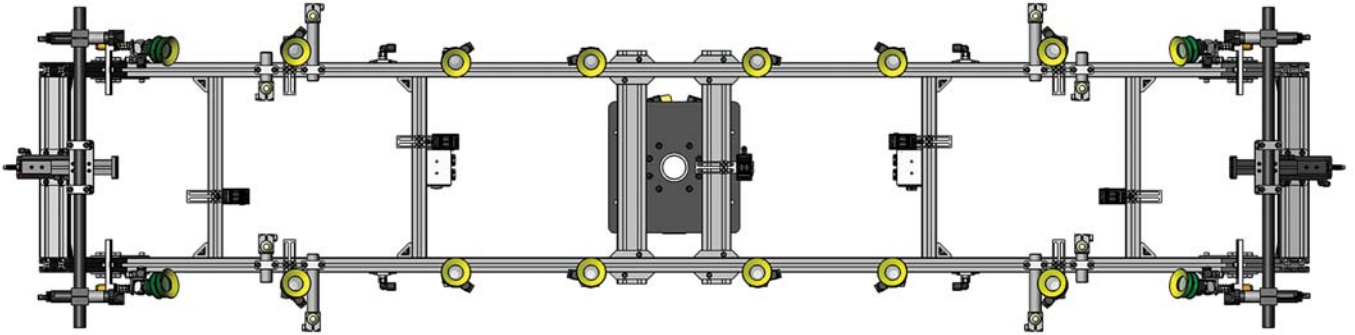

Degating on the EOAT

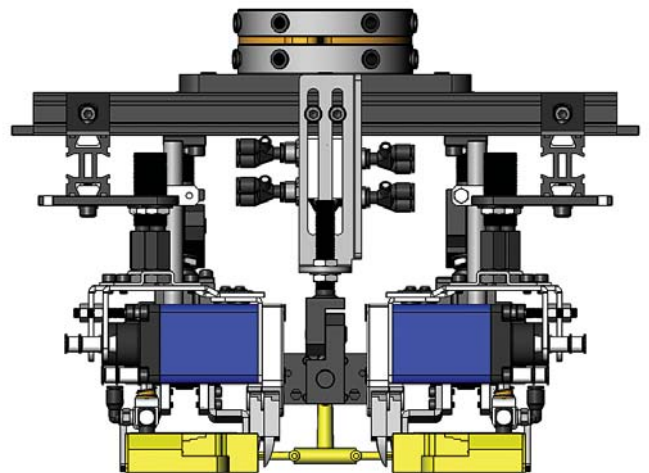
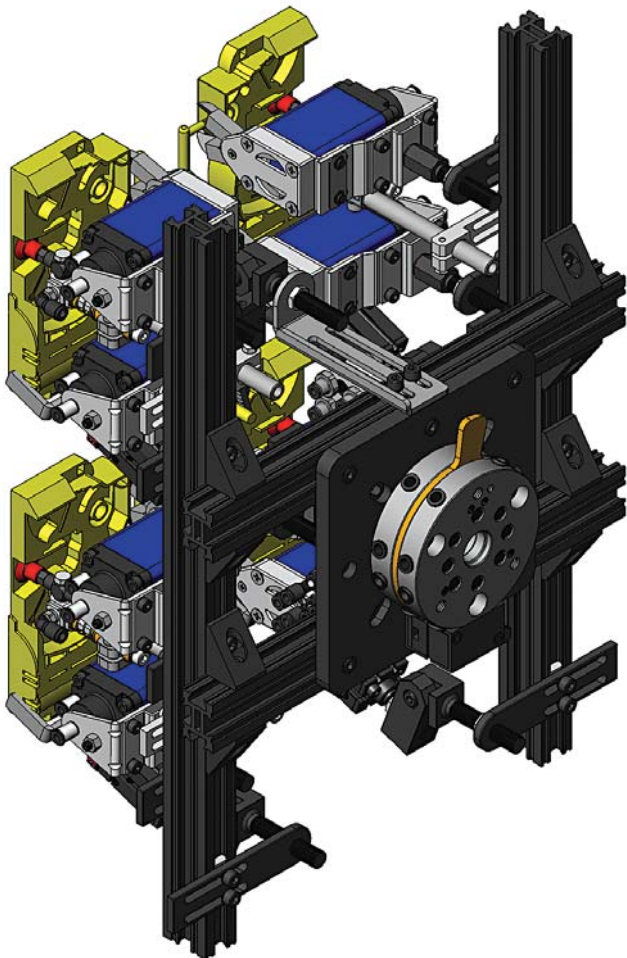
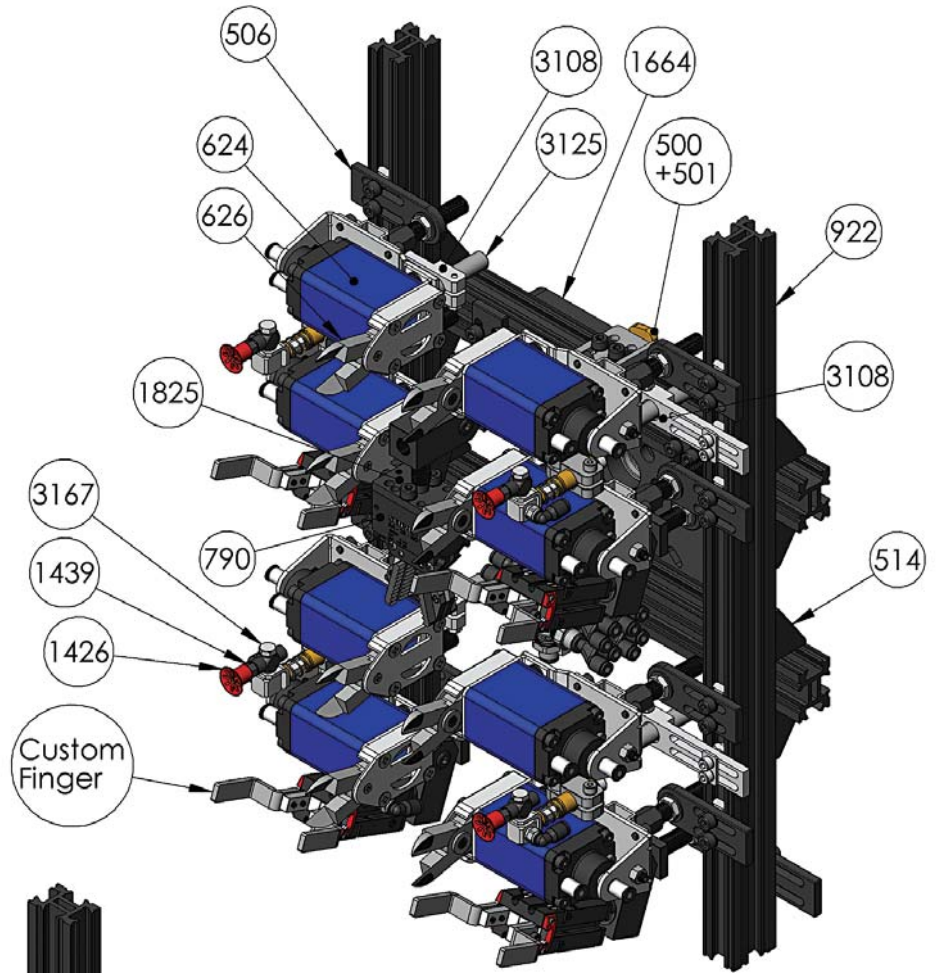

Degating on the EOAT

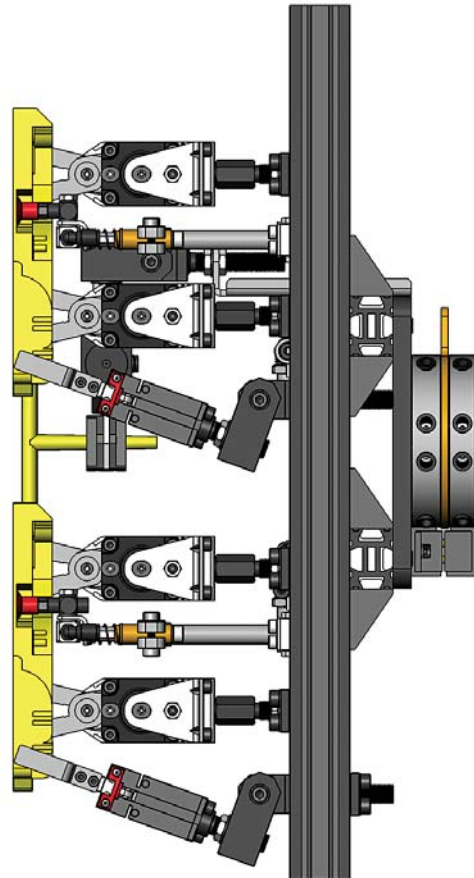
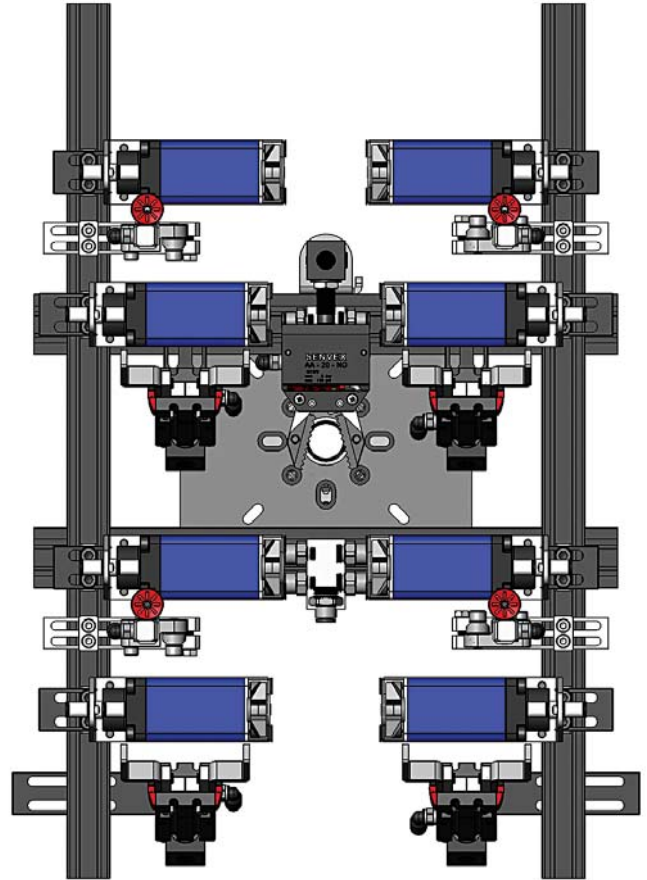
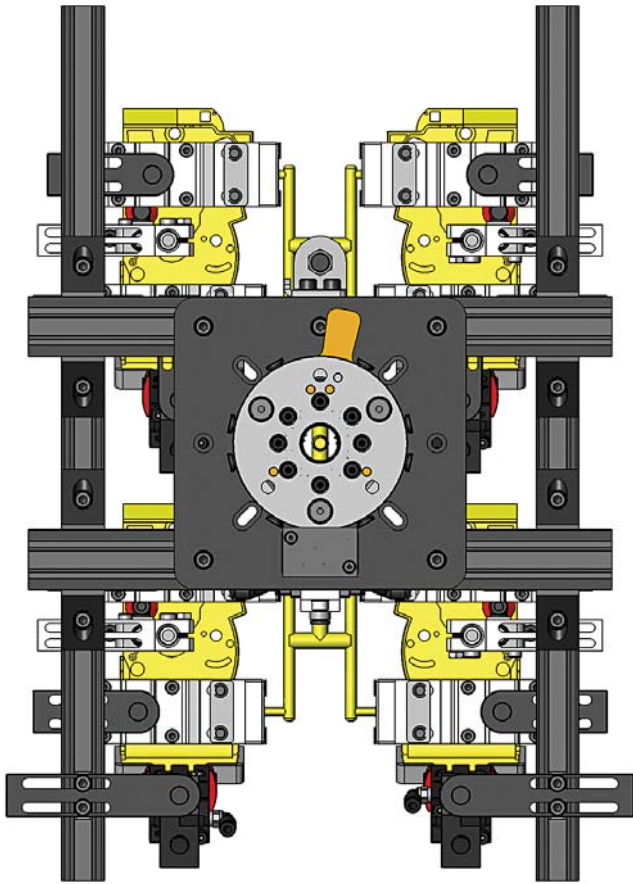

Family mold with nipping and sprue gripping

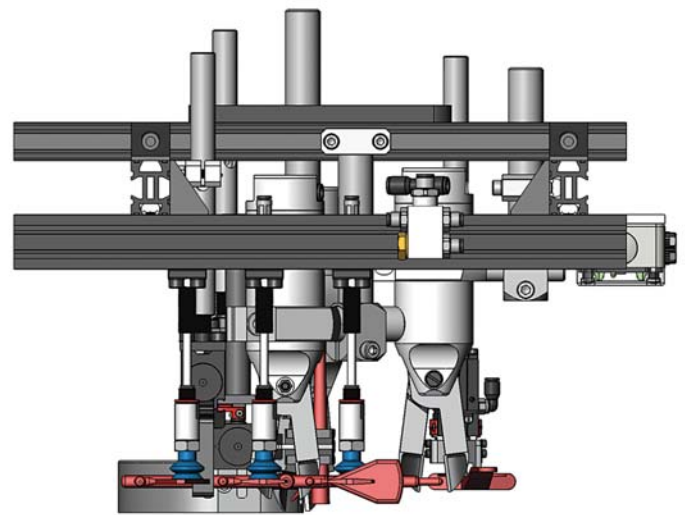
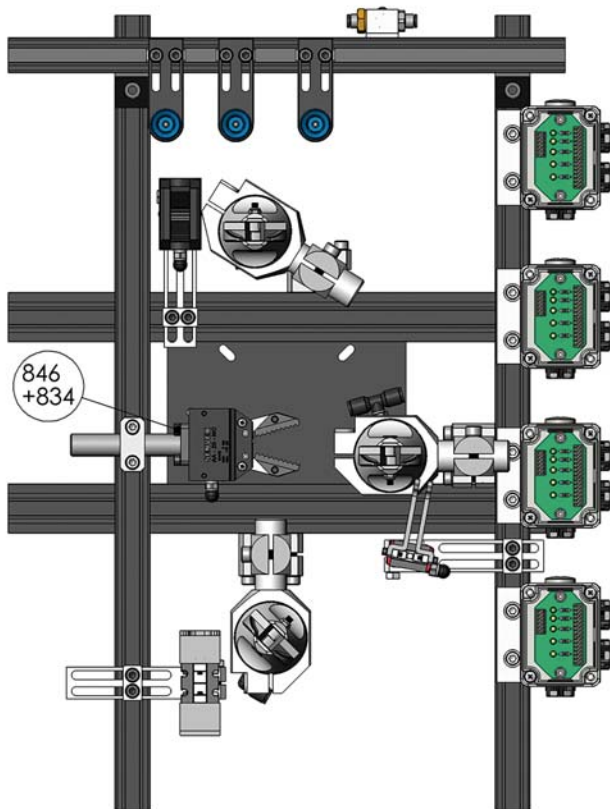
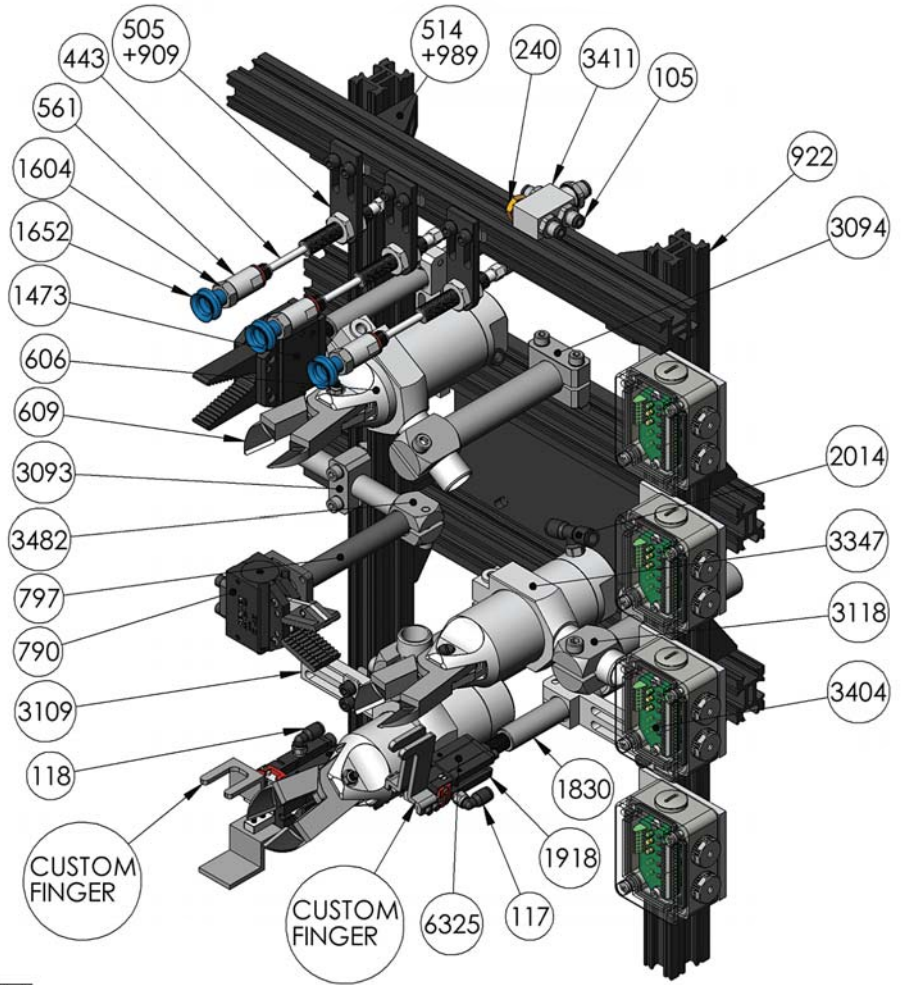

Family mold with nipping and sprue gripping

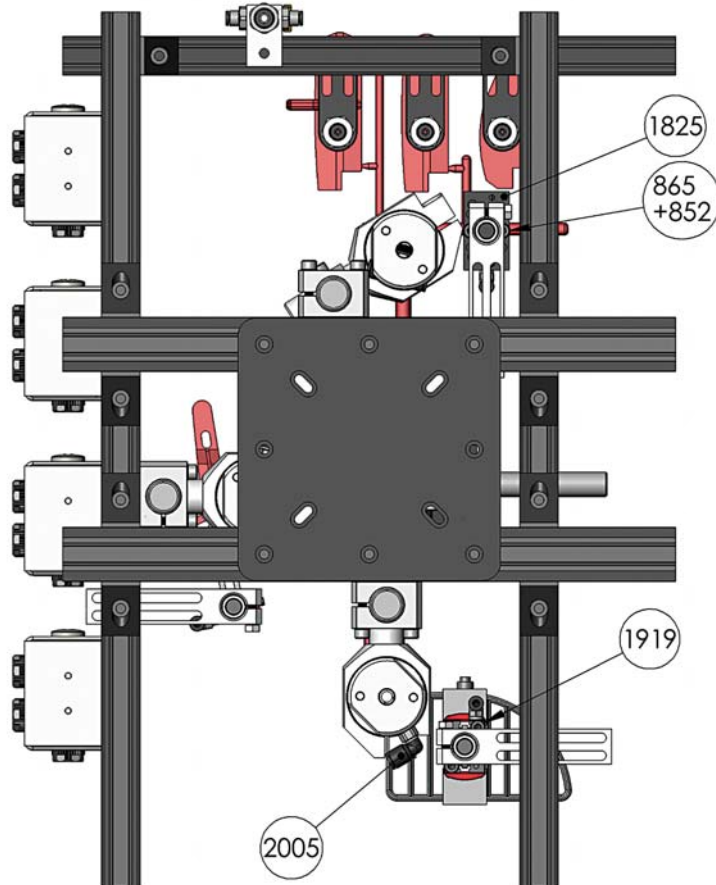
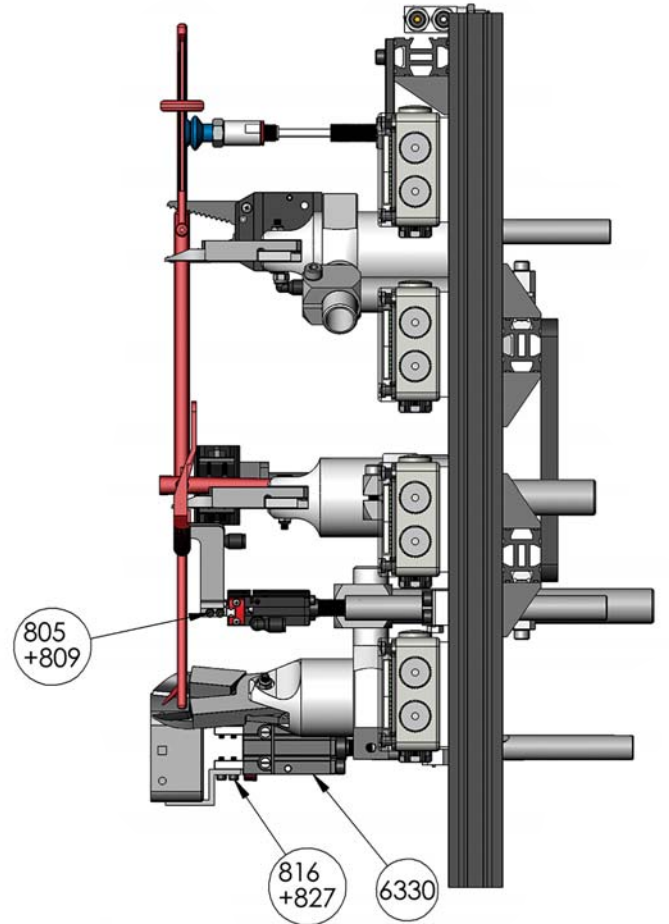
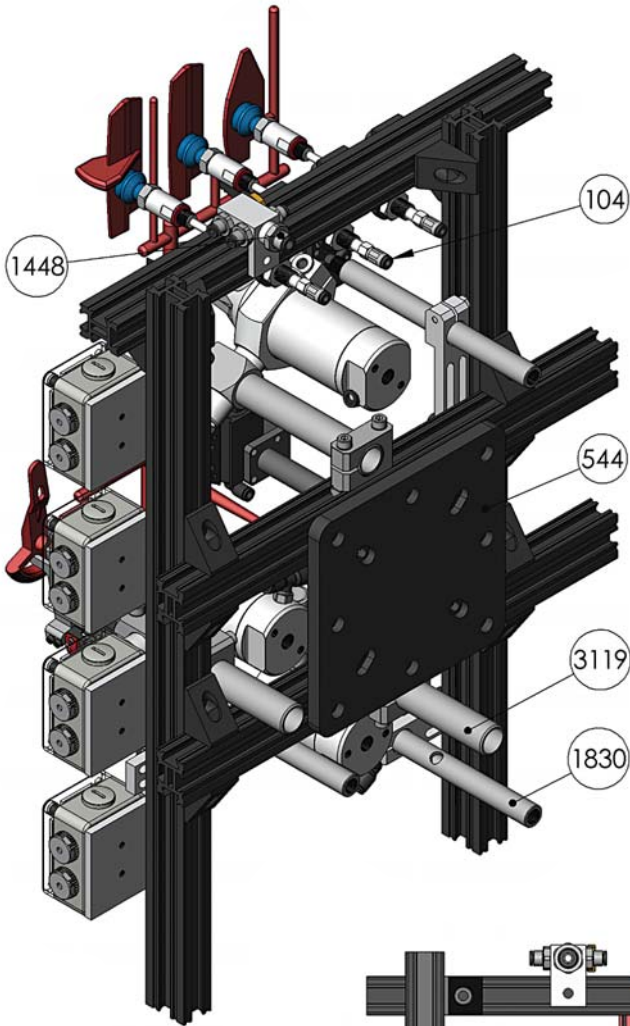

Degating using offset-reverse nipper blades

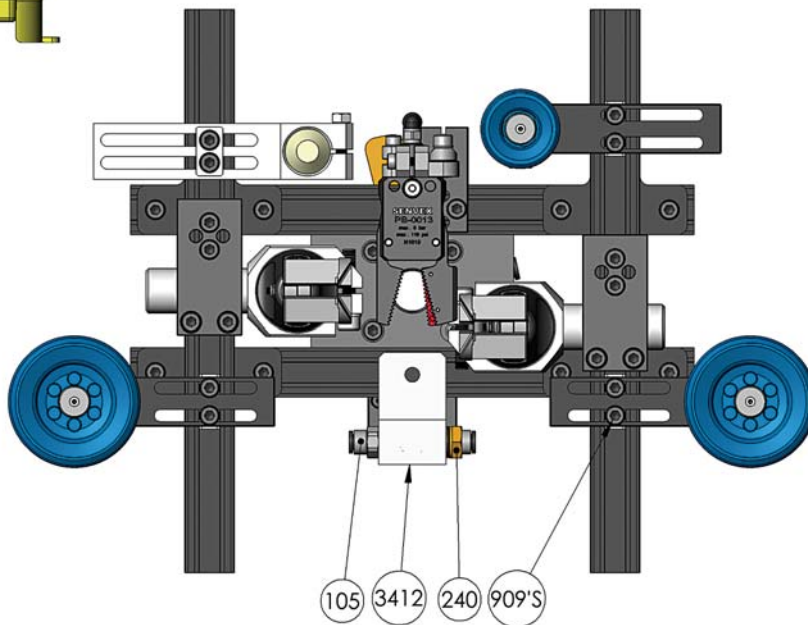
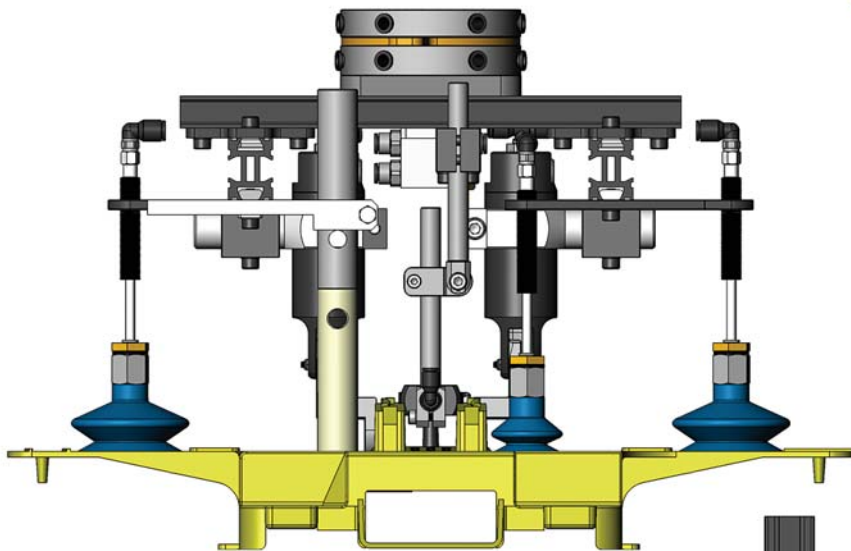
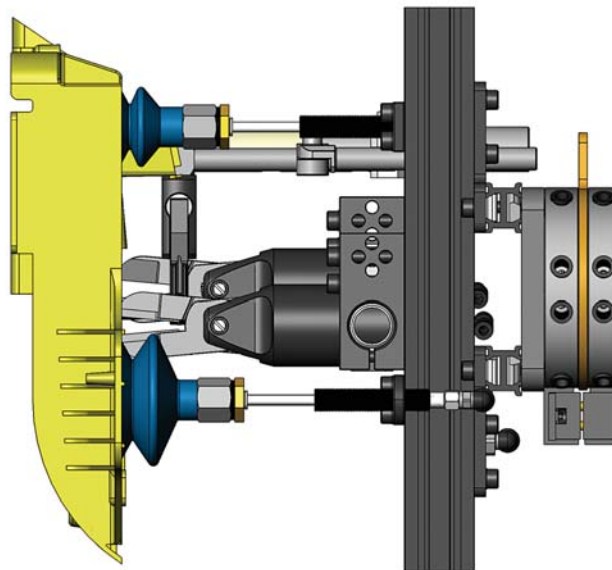
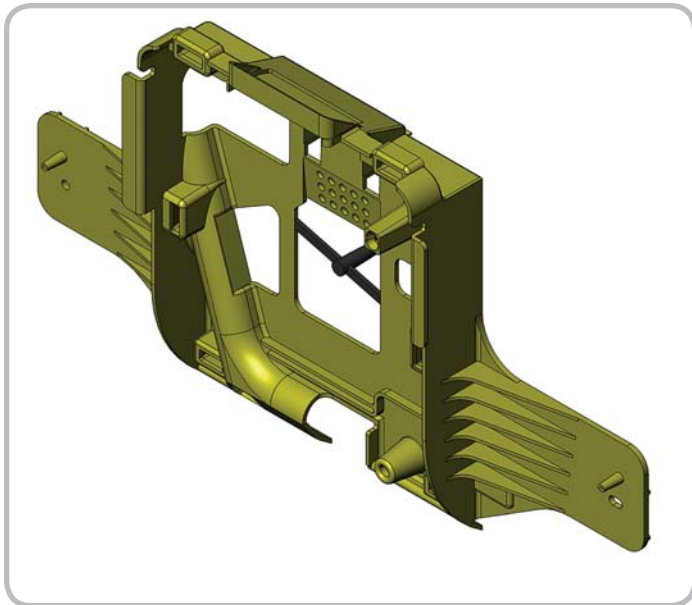

Degating using offset-reverse nipper blades

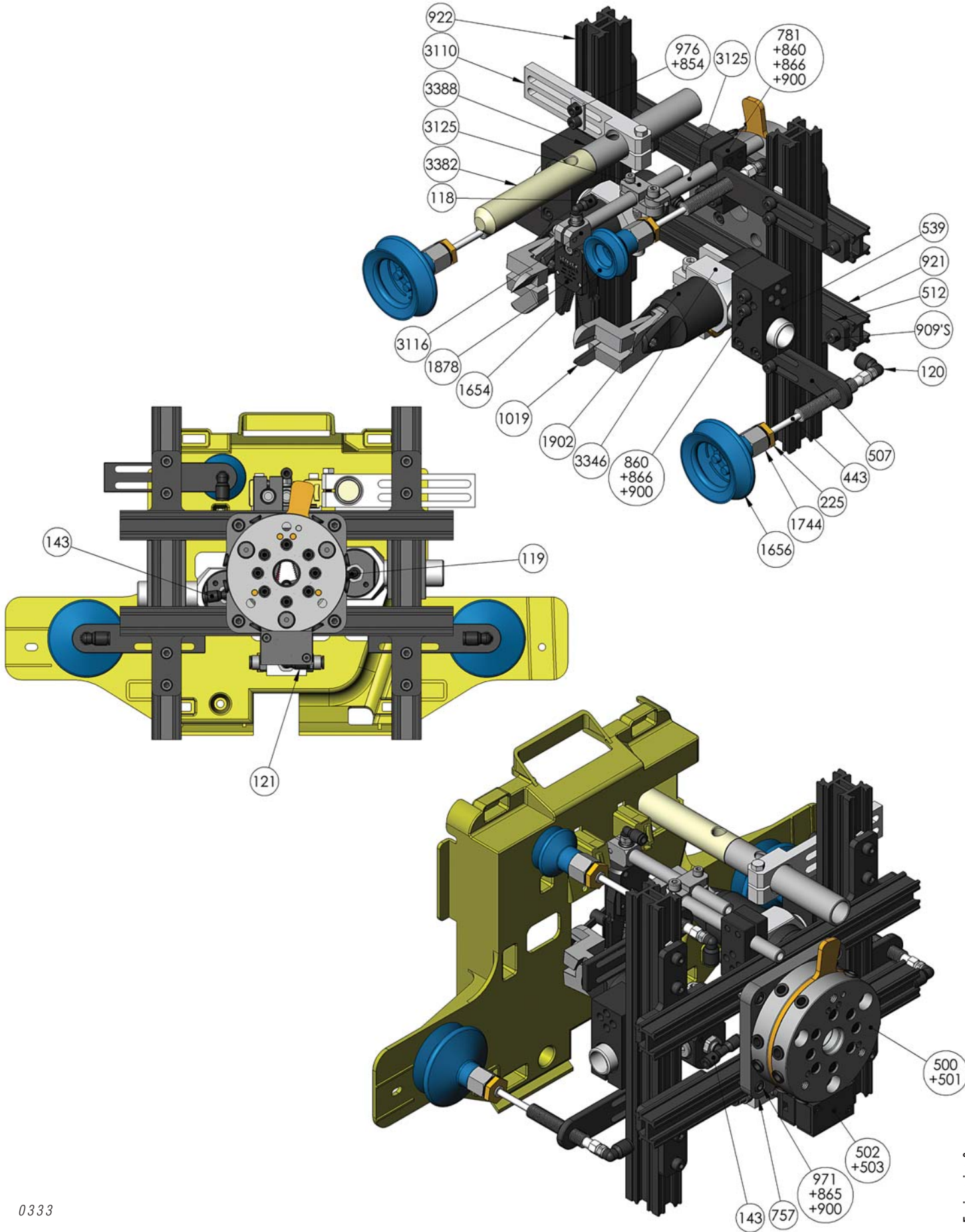

Lightweight cylinders to grip the part, vacuum cups to stabilize it

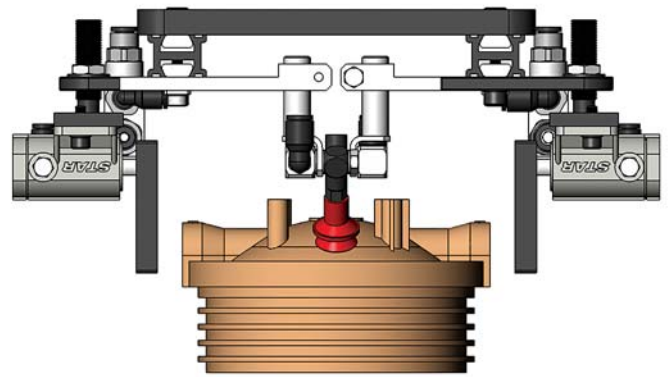
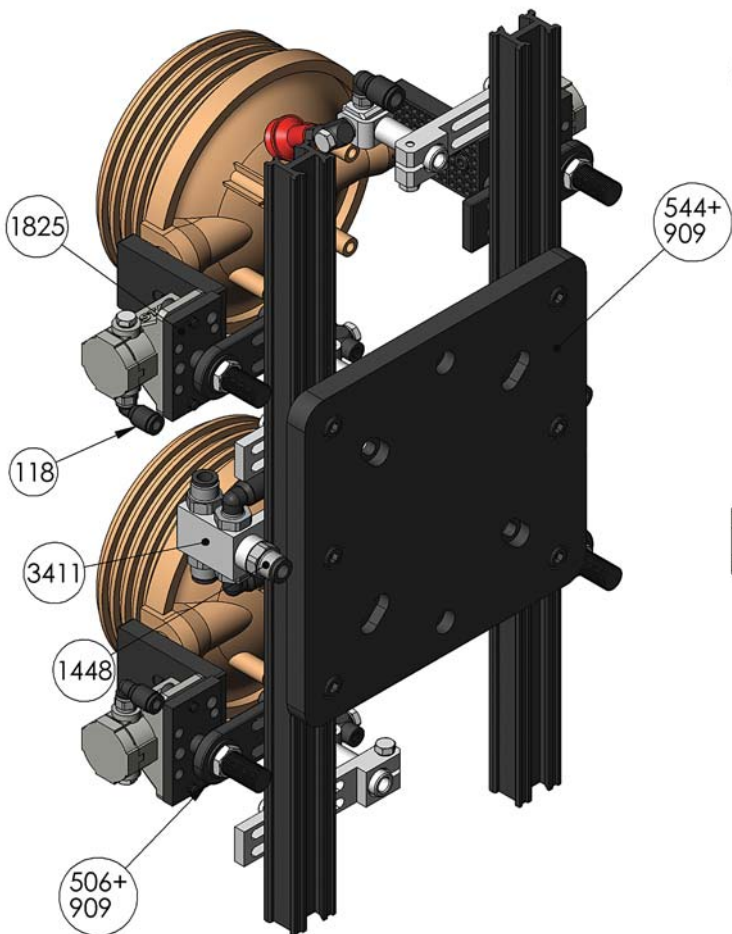
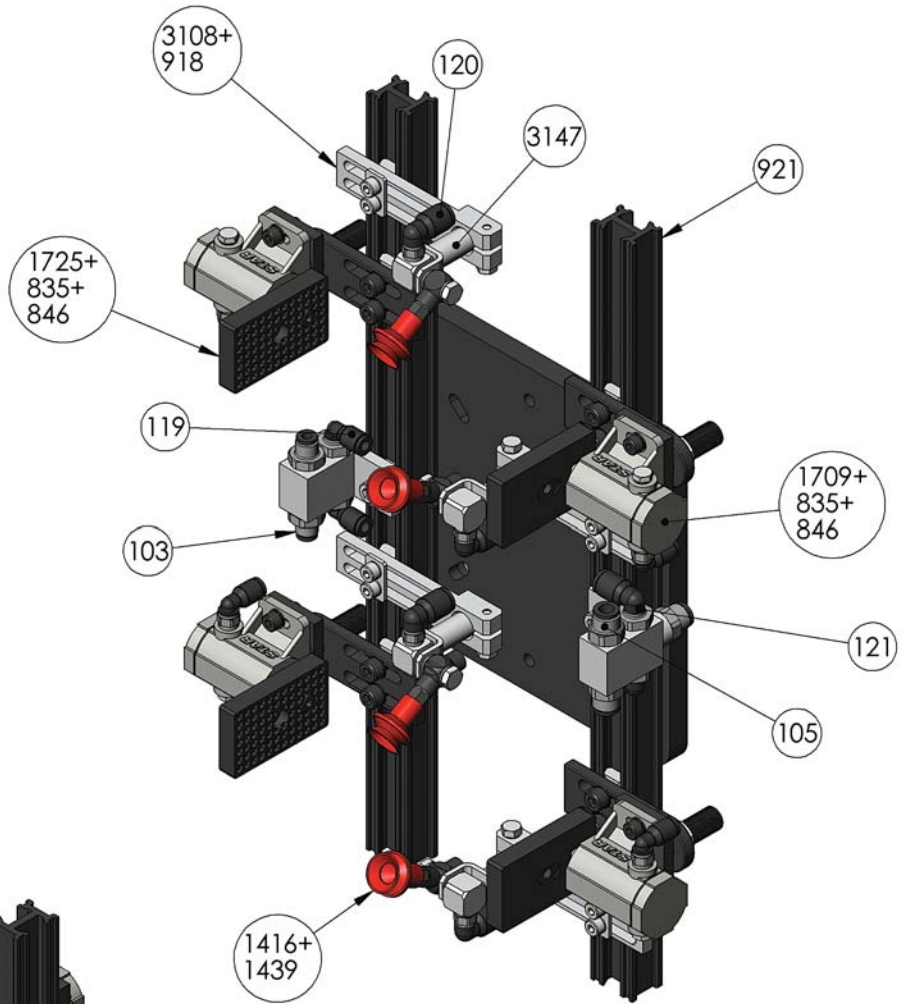
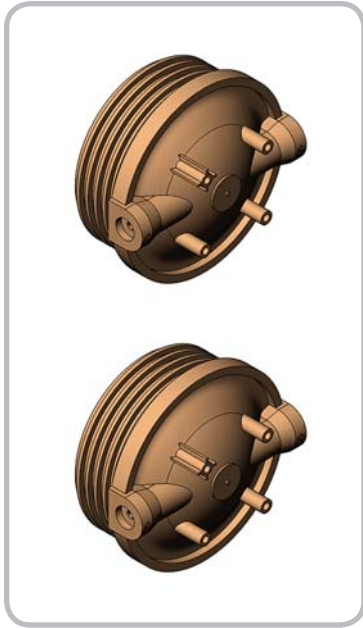

Lightweight cylinders to grip the part, vacuum cups to stabilize it

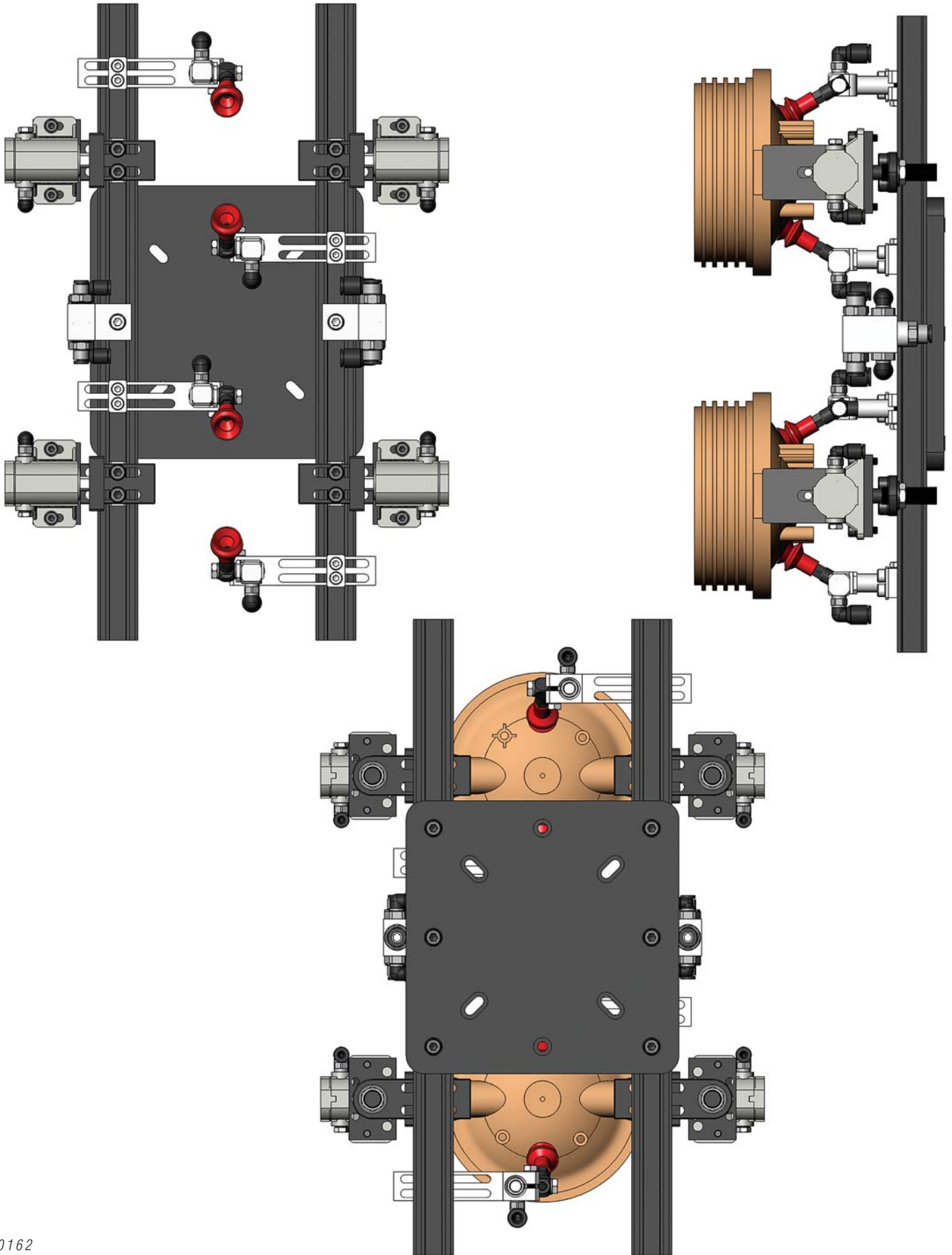

EOAT for a 6½" mold opening

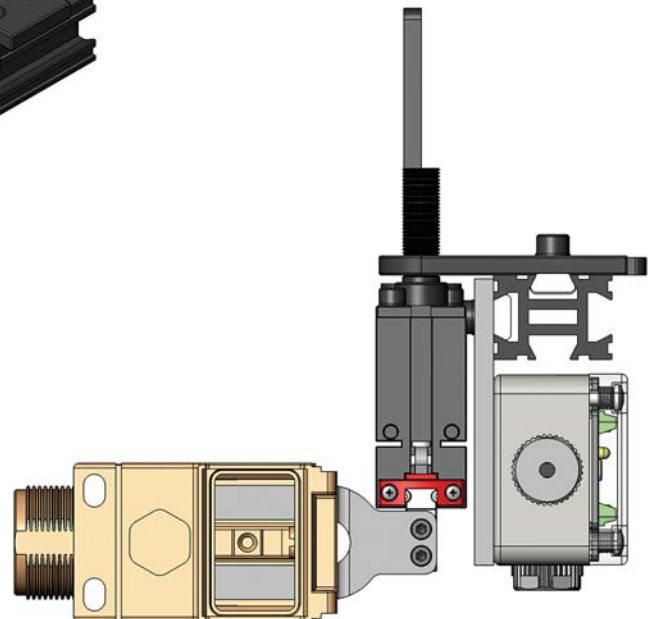
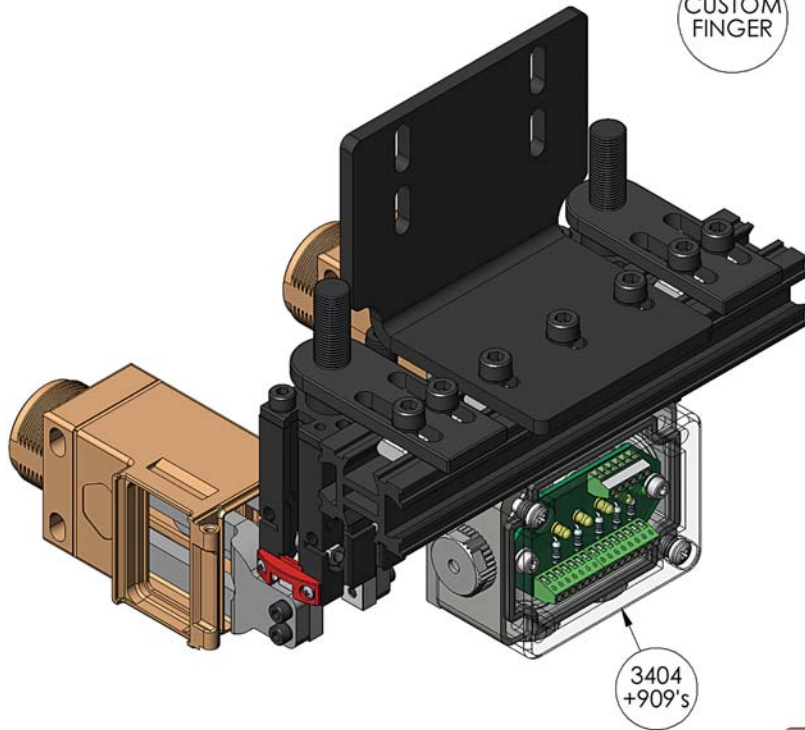
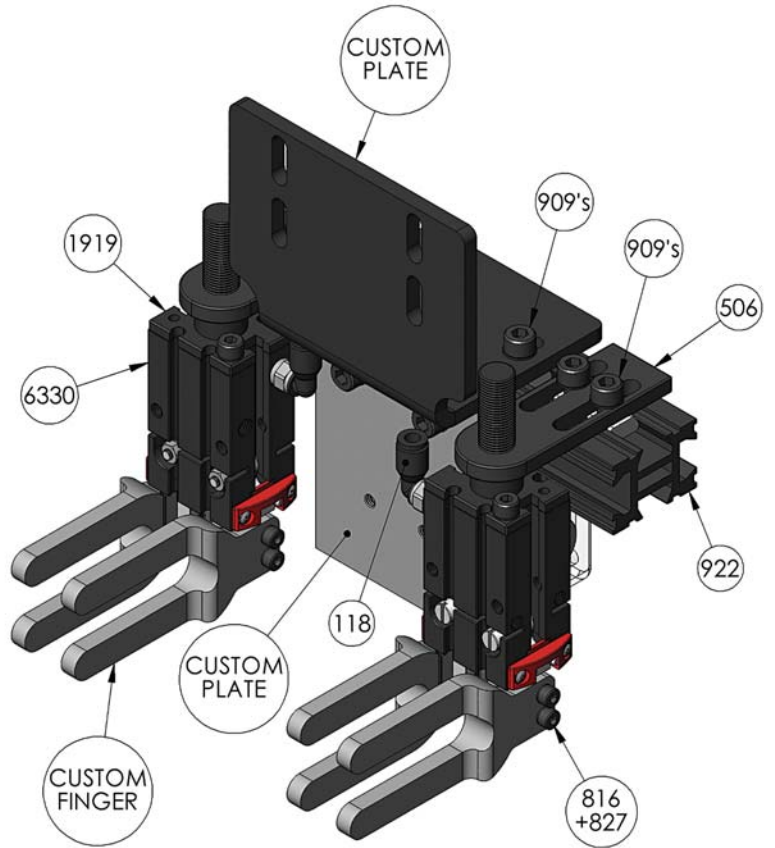
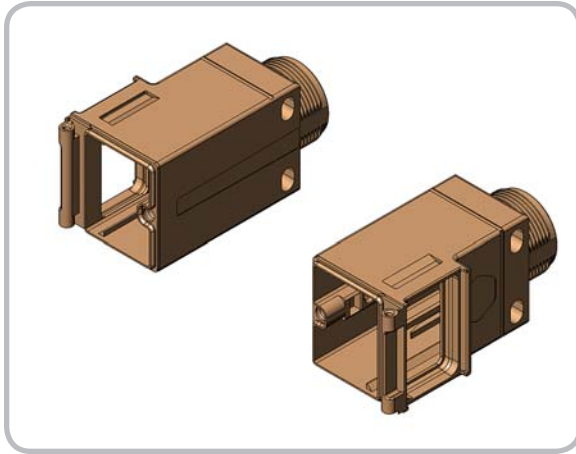

EOAT for a 6½" mold opening

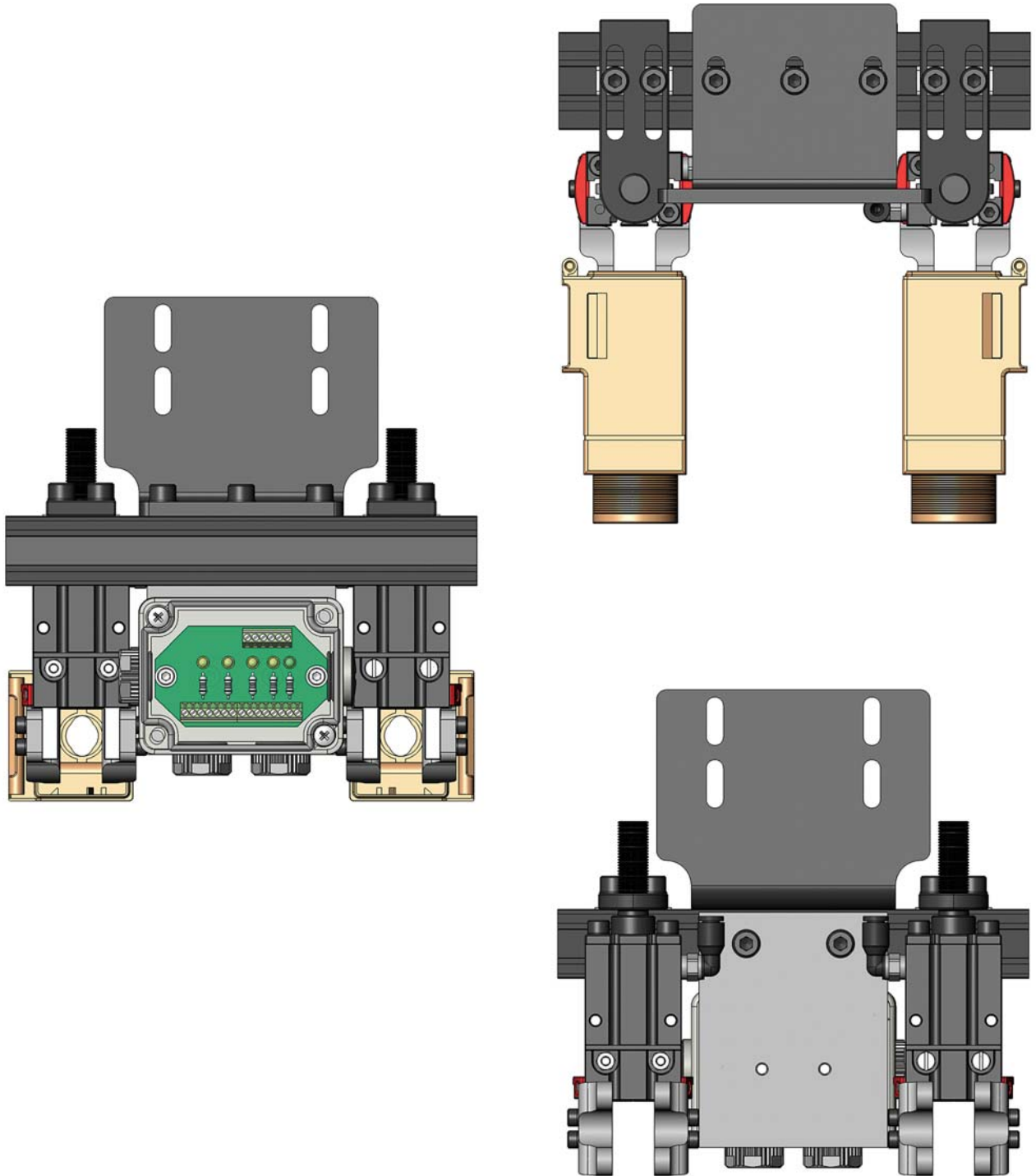

Radial grippers to pull parts from mold then set parts upright on conveyor

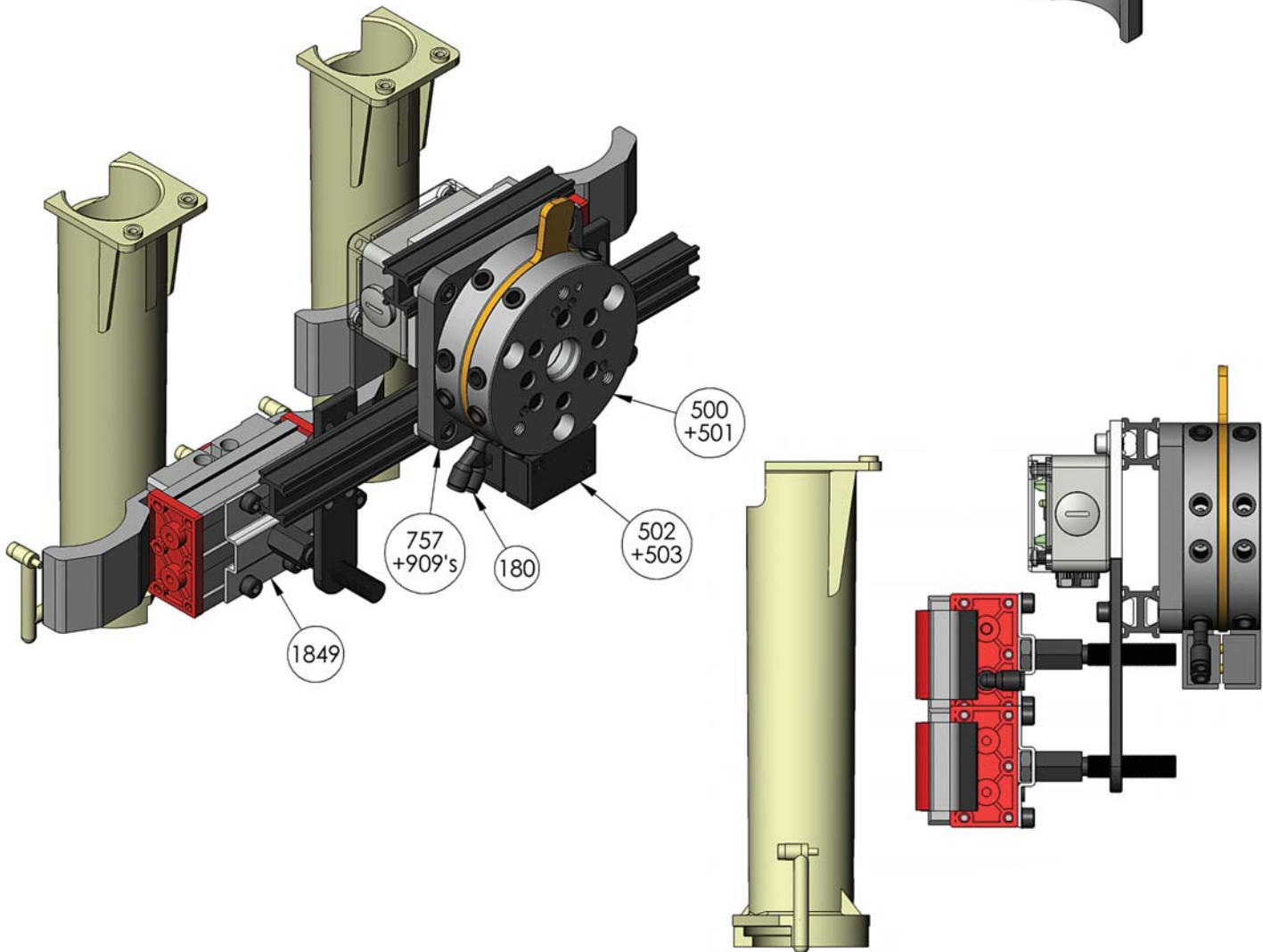
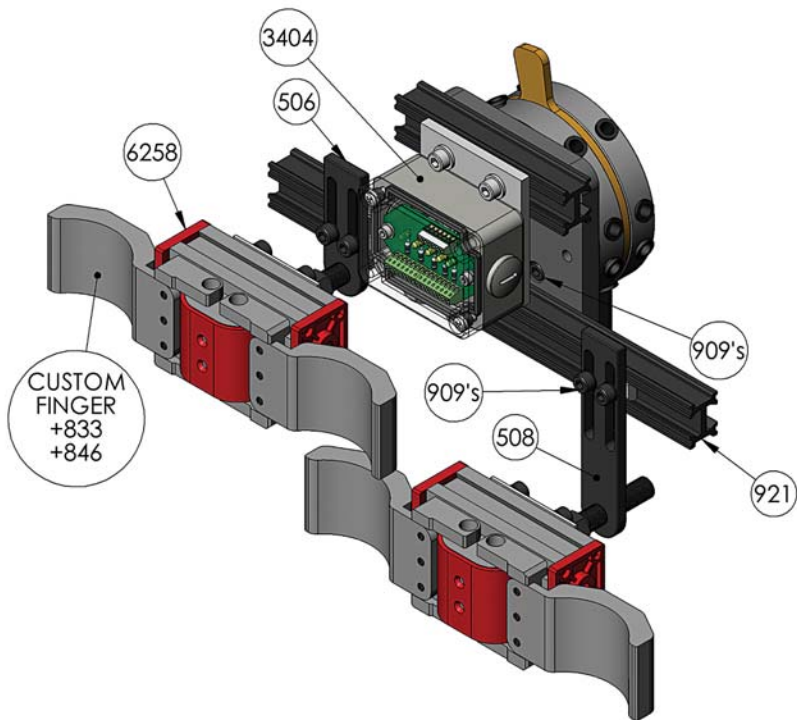
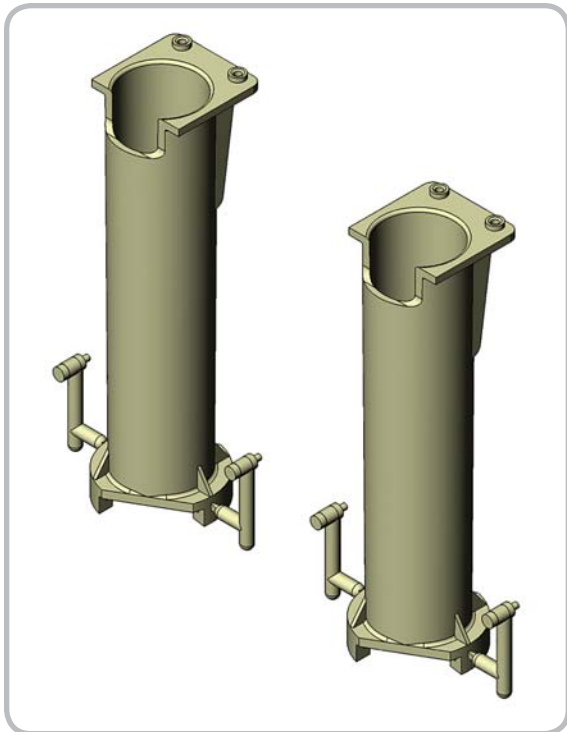

Radial grippers to pull parts from mold then set parts upright on conveyor

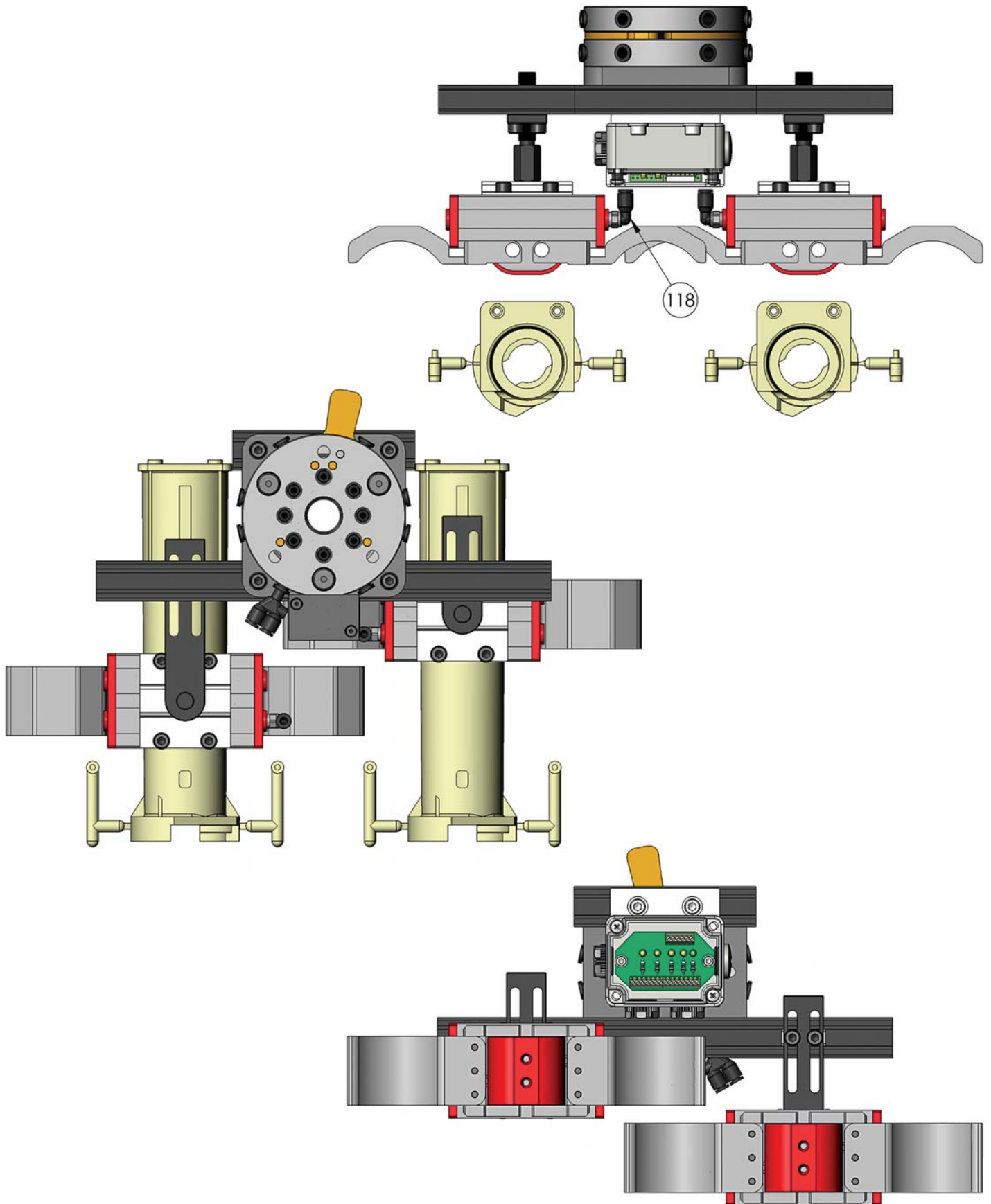

Oval vacuum cup use

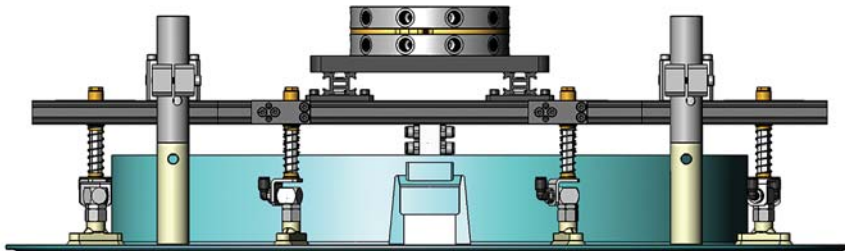
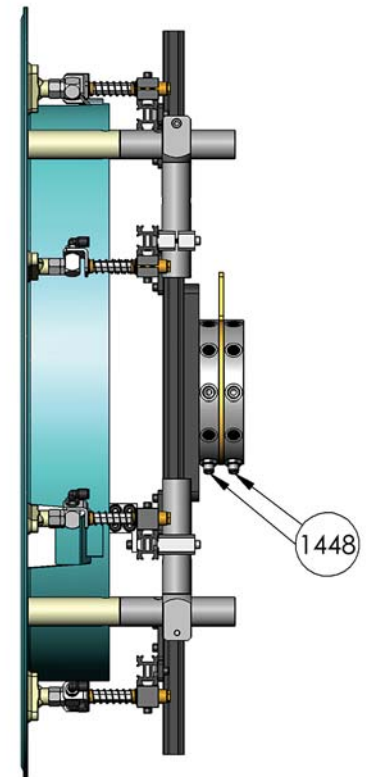
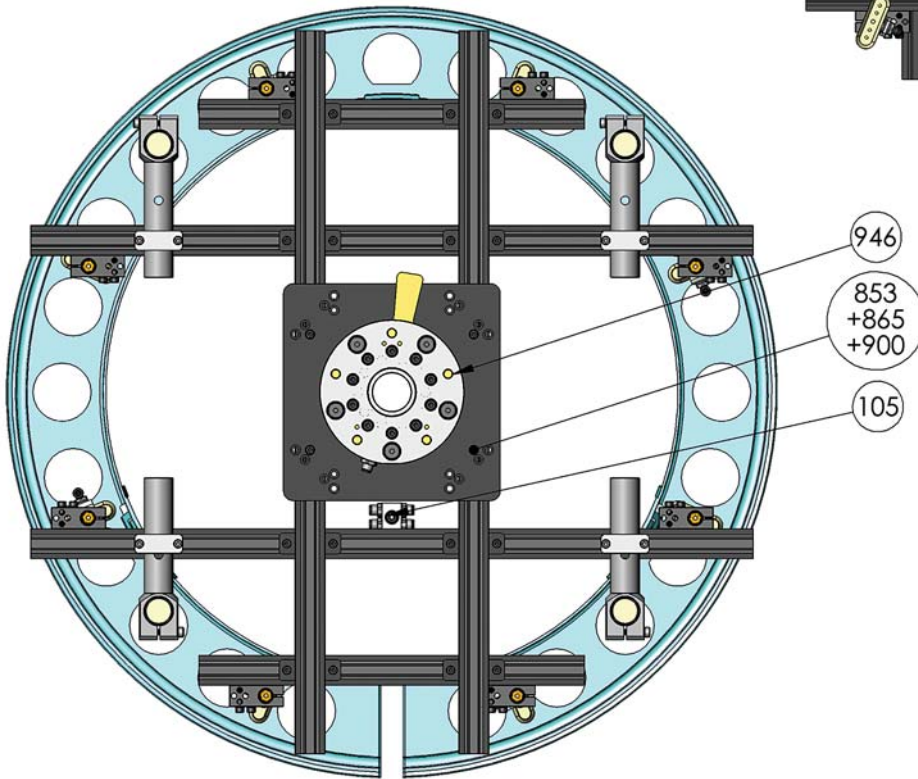
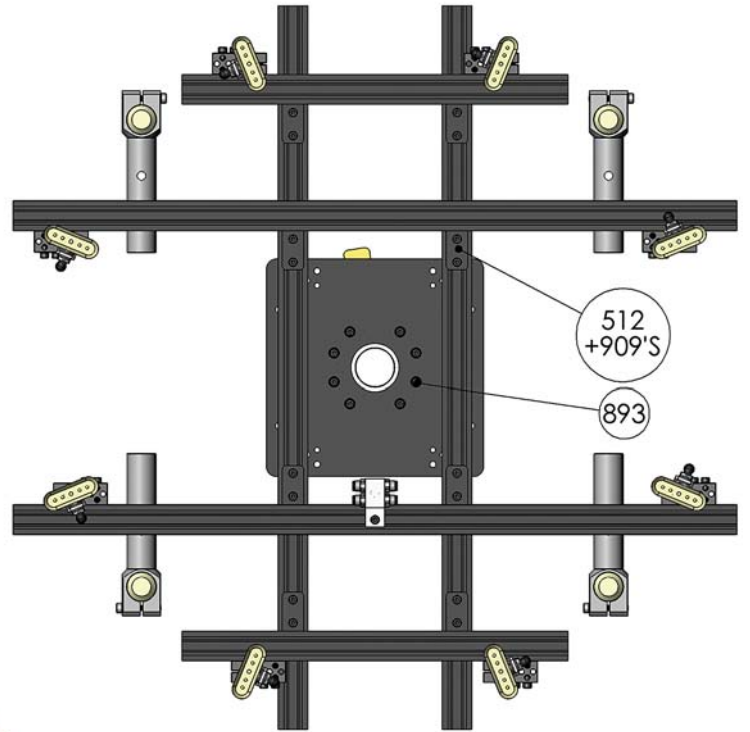

Oval vacuum cup use

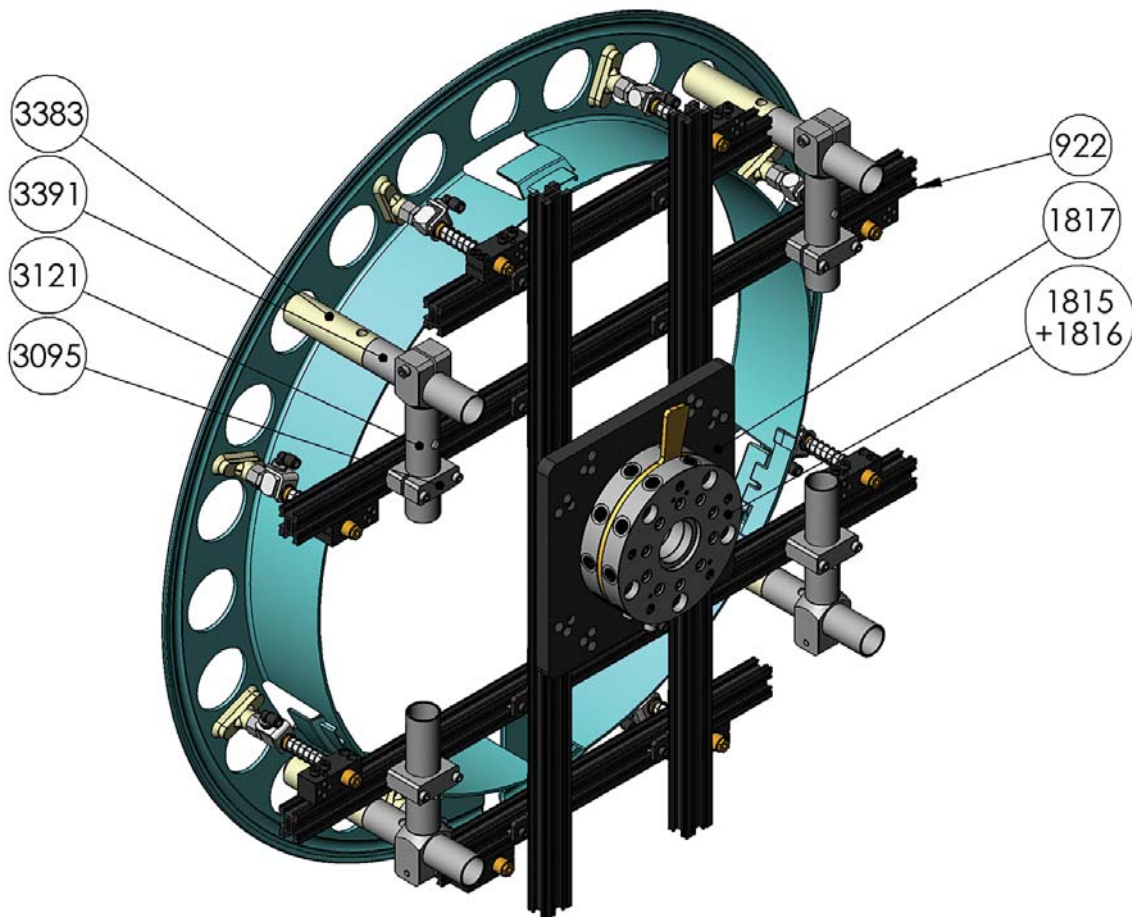
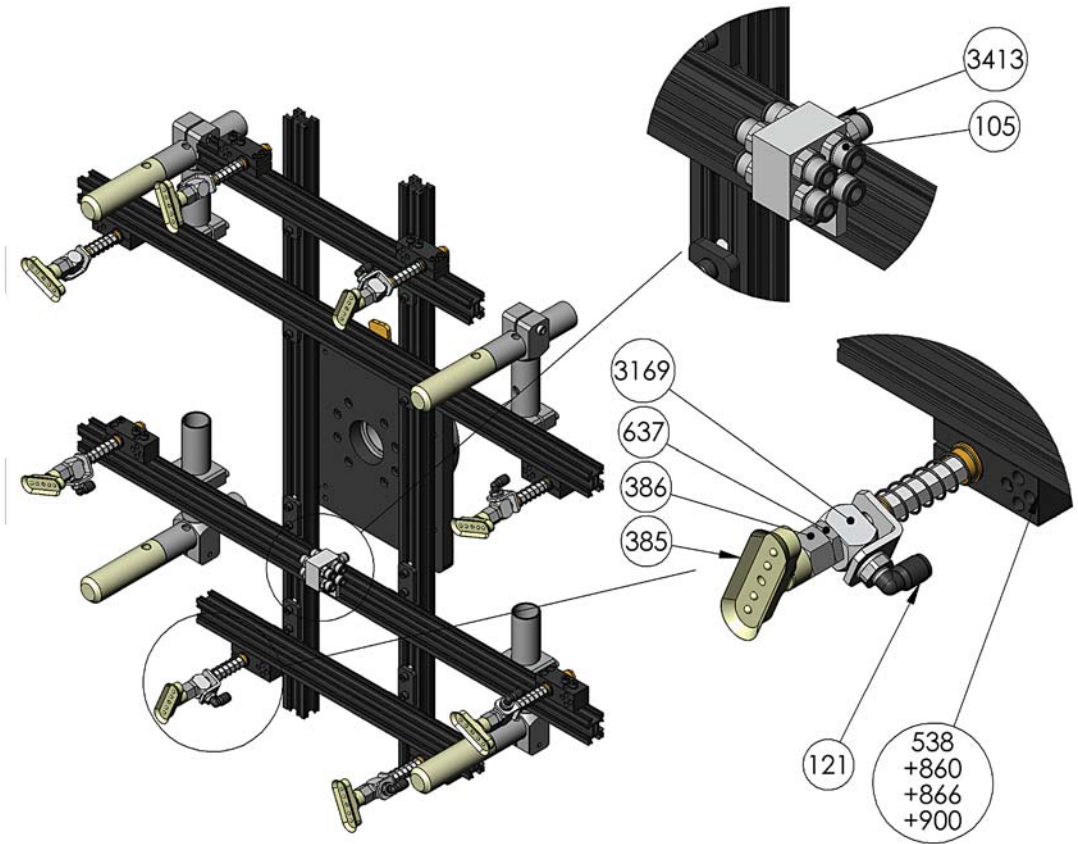

Simple EOAT using sprue grippers

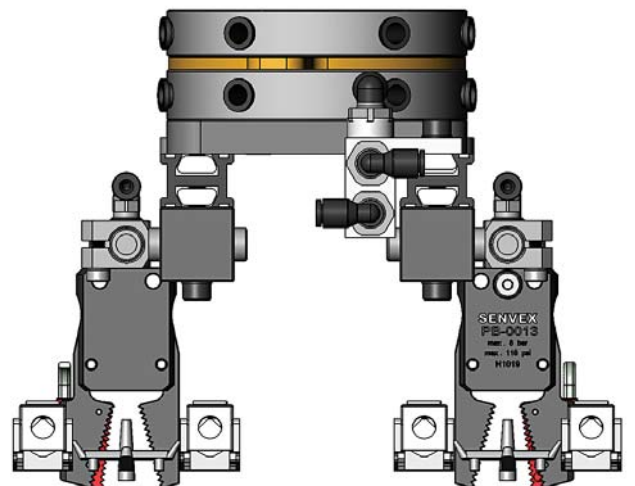
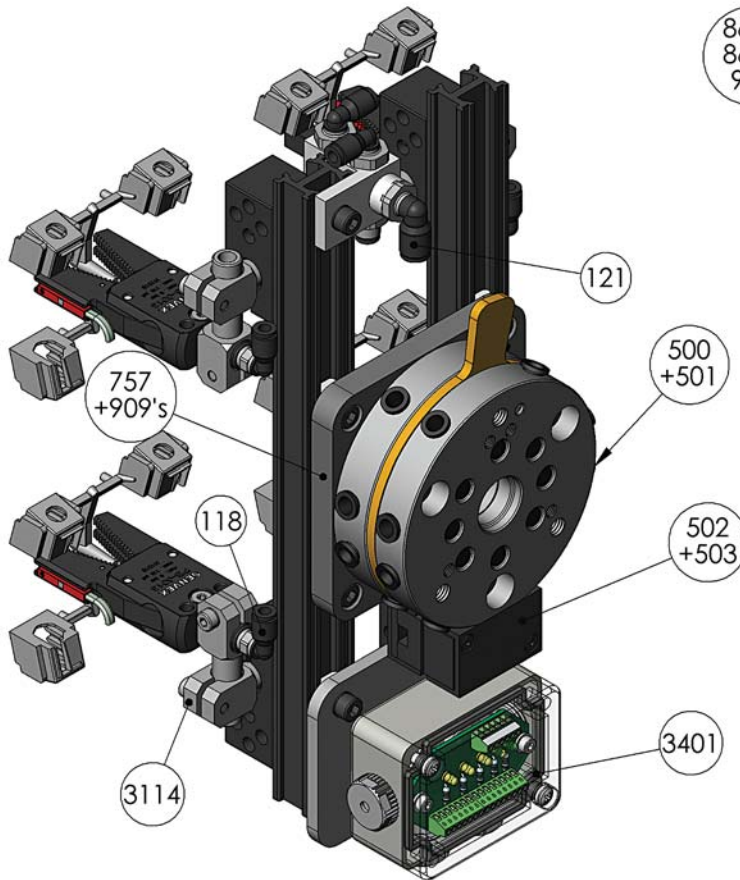
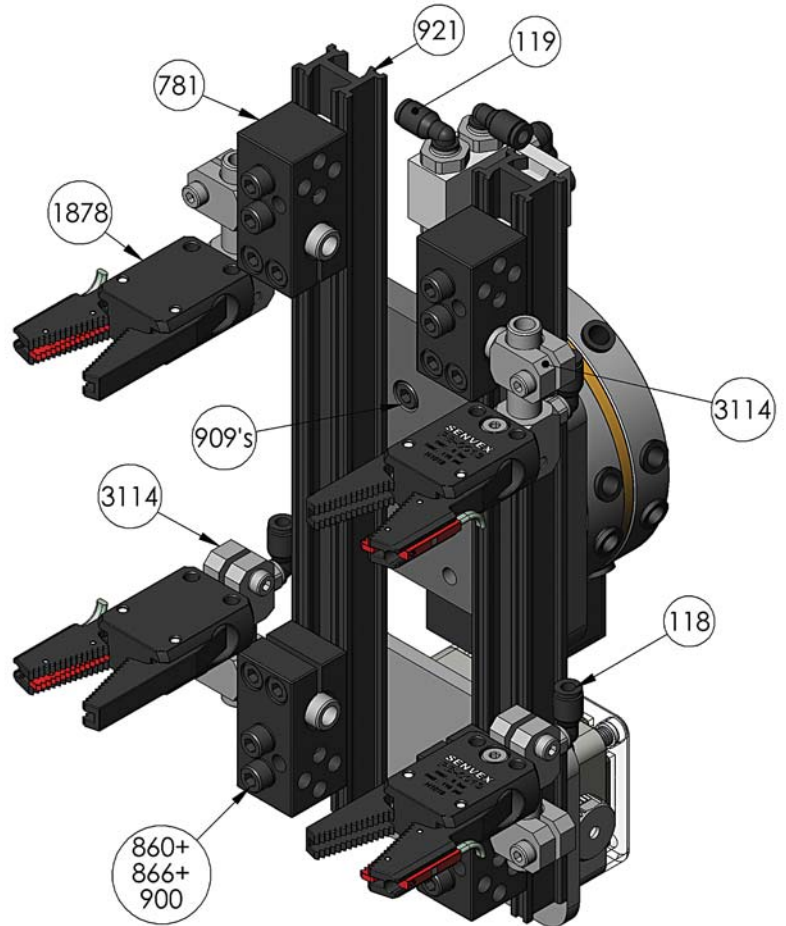

Simple EOAT using sprue grippers

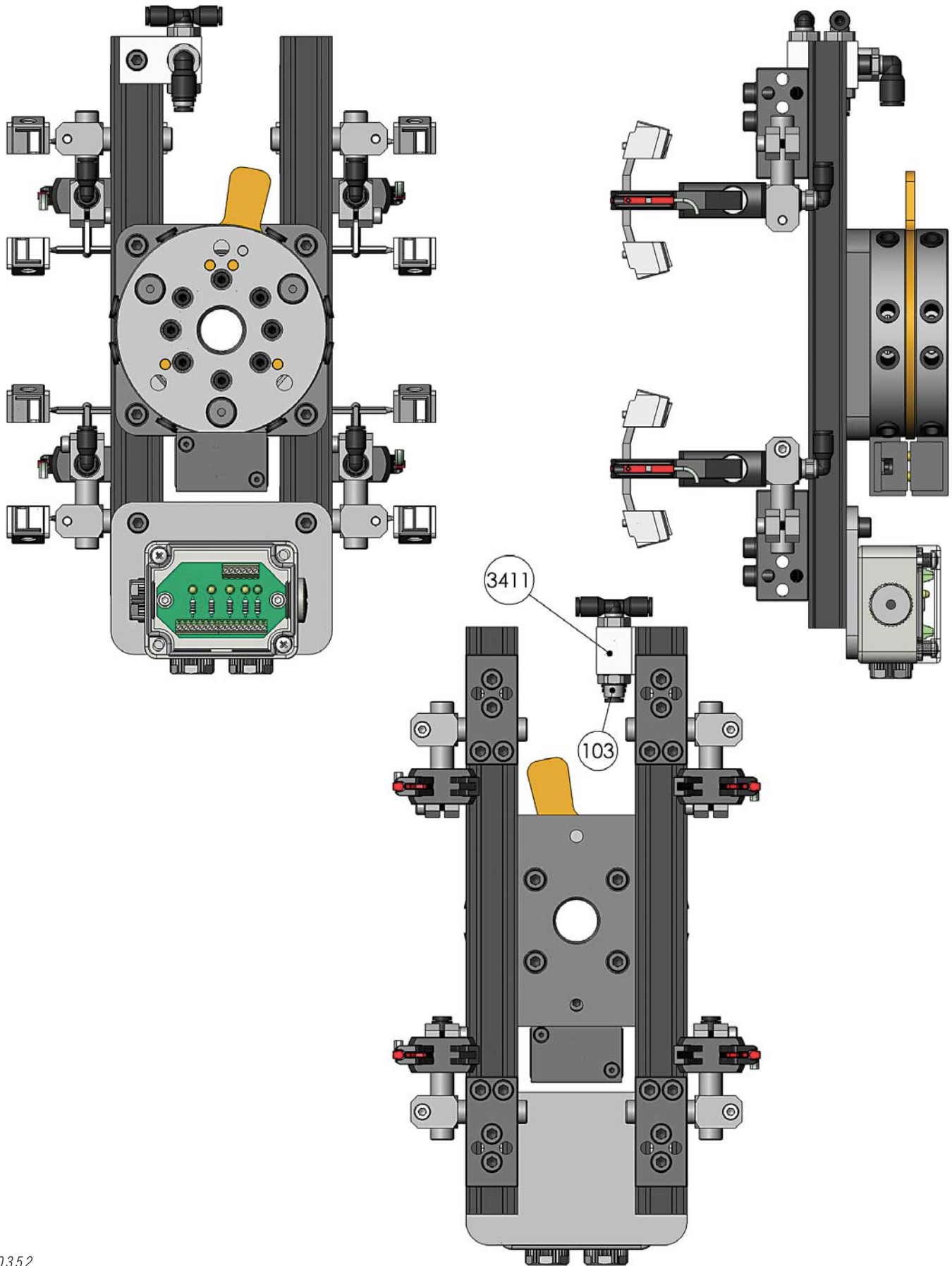

Offset nipper blade to degate inside of part

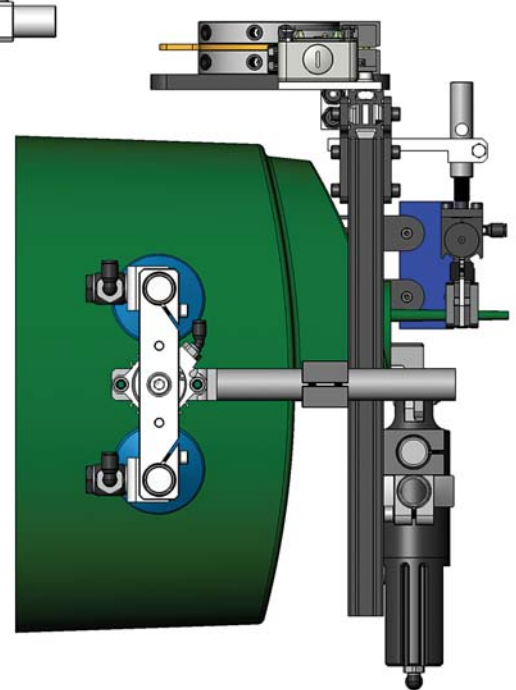
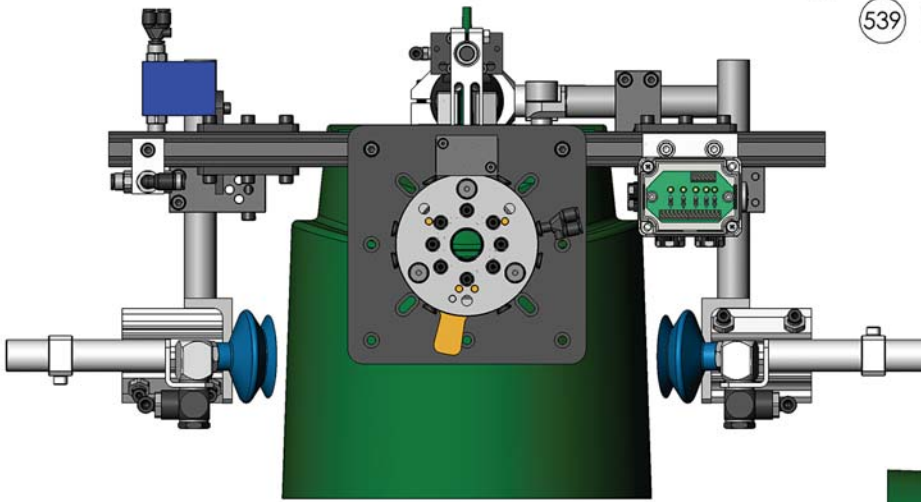
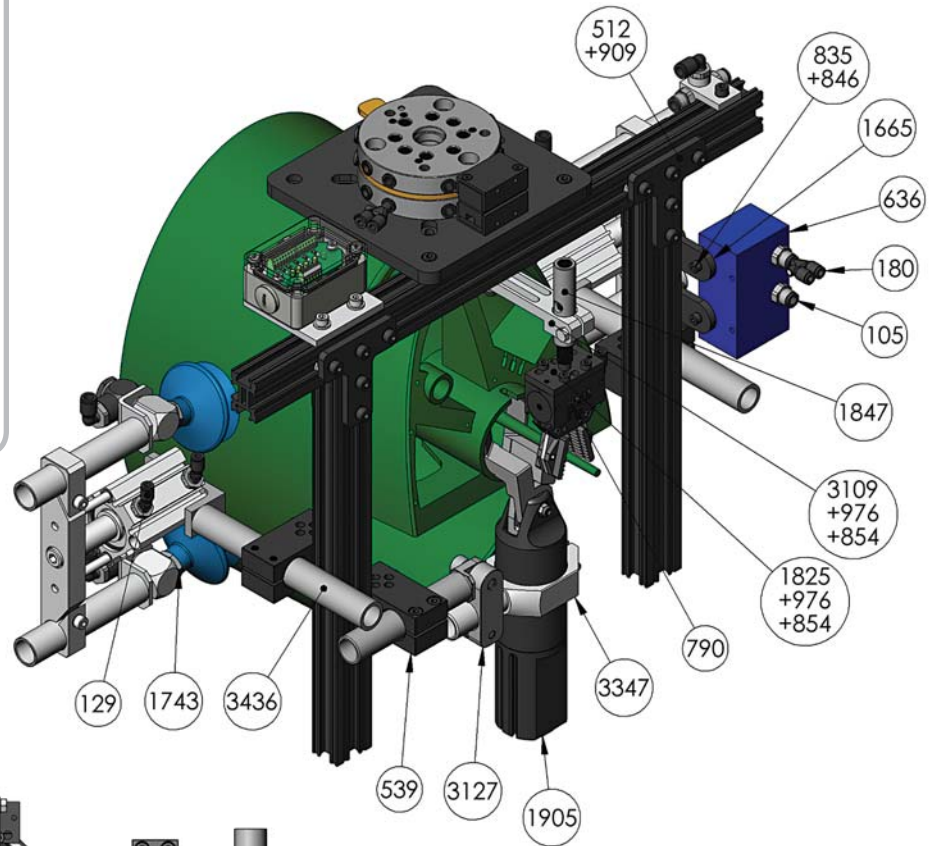
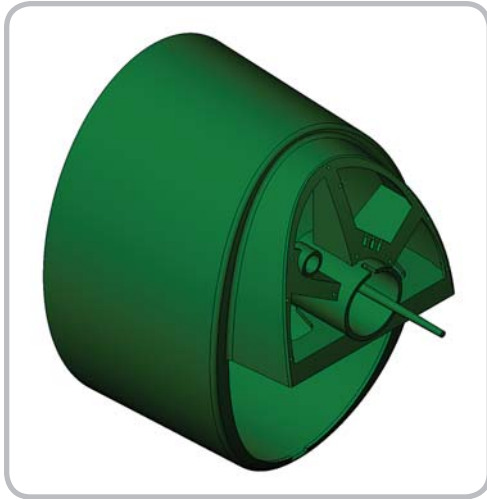

Offset nipper blade to degate inside of part

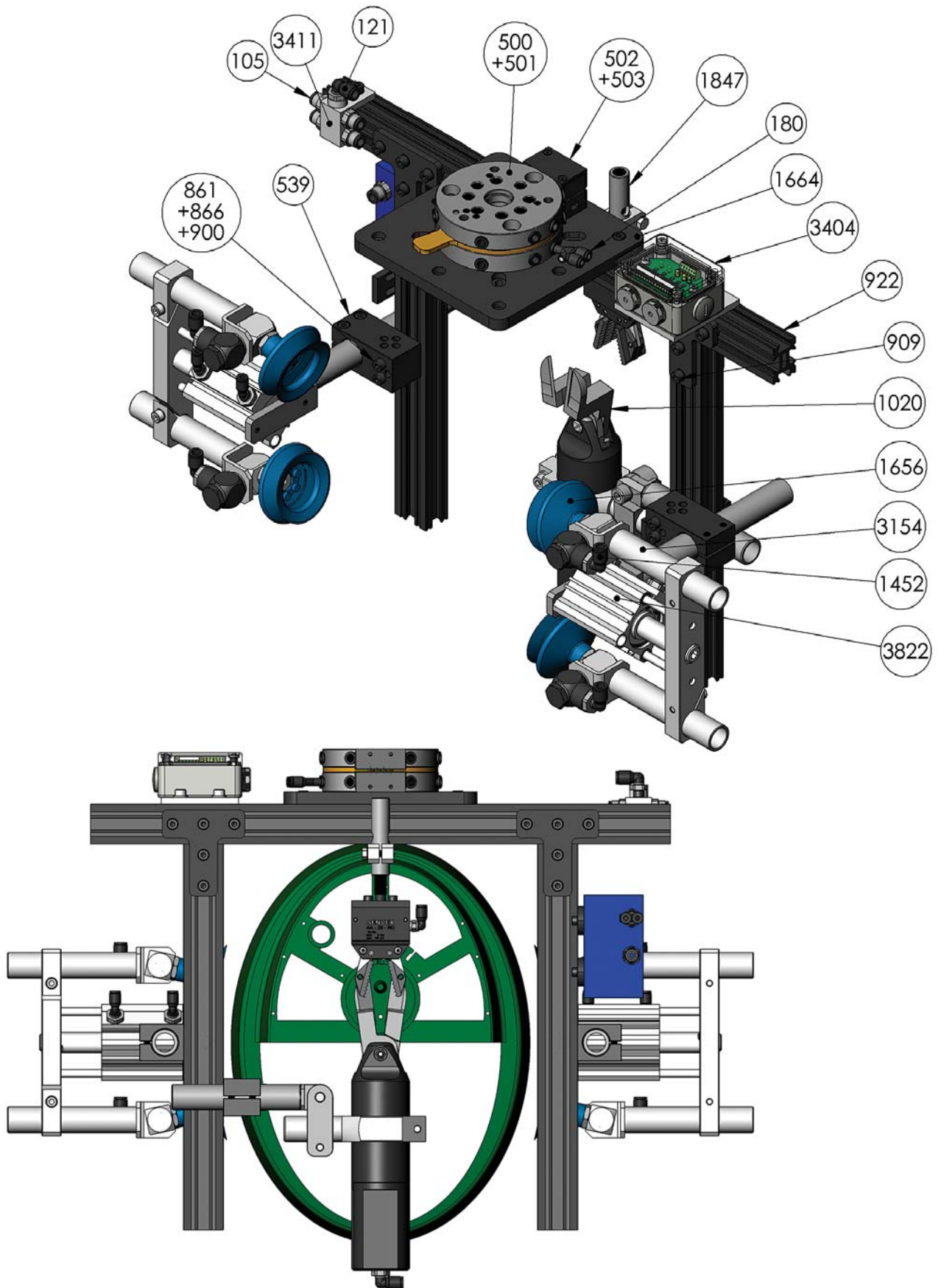

Only 3" of part exposed outside mold to grab onto—use finger grippers

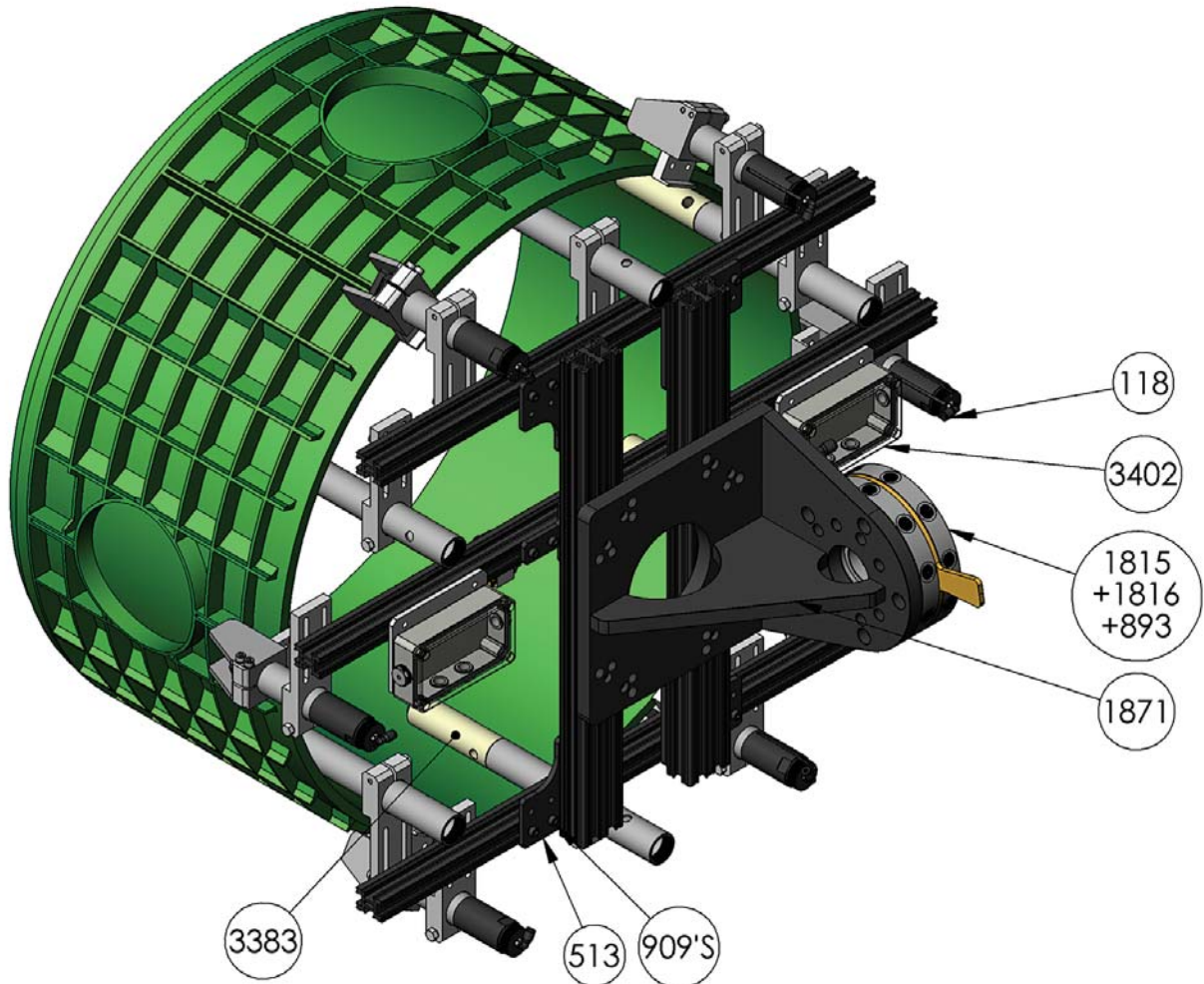
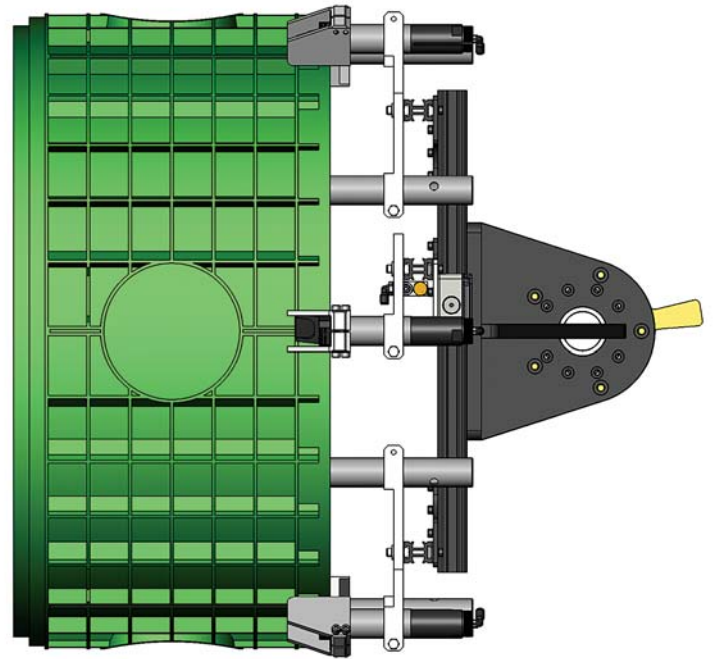

Only 3" of part exposed outside mold to grab onto—use finger grippers

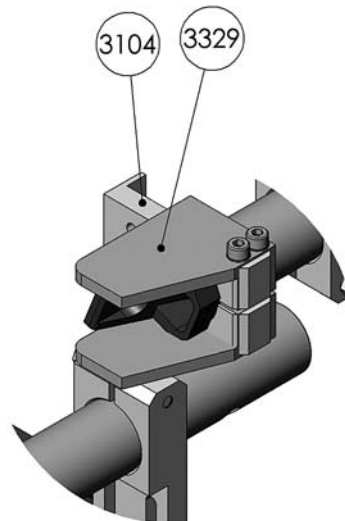
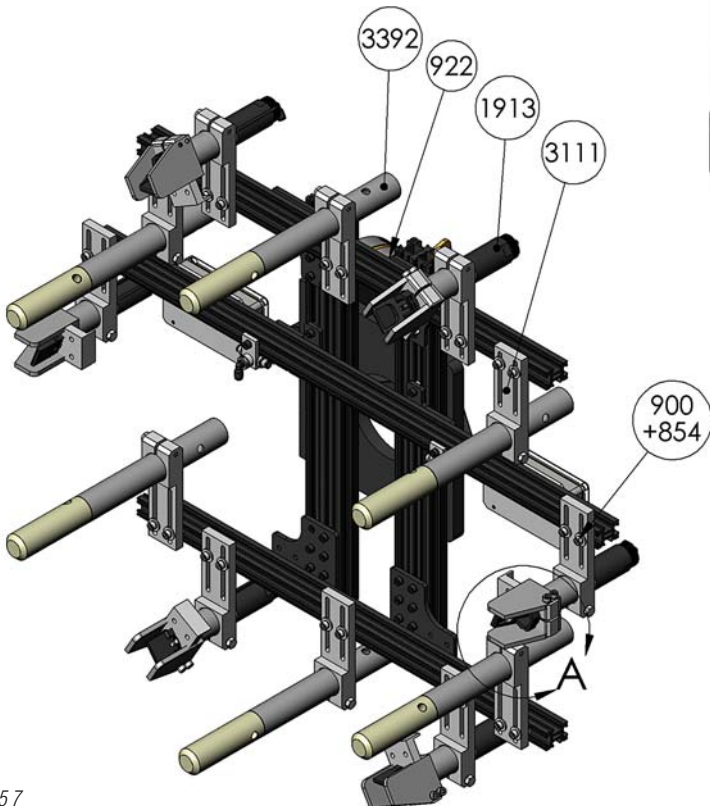
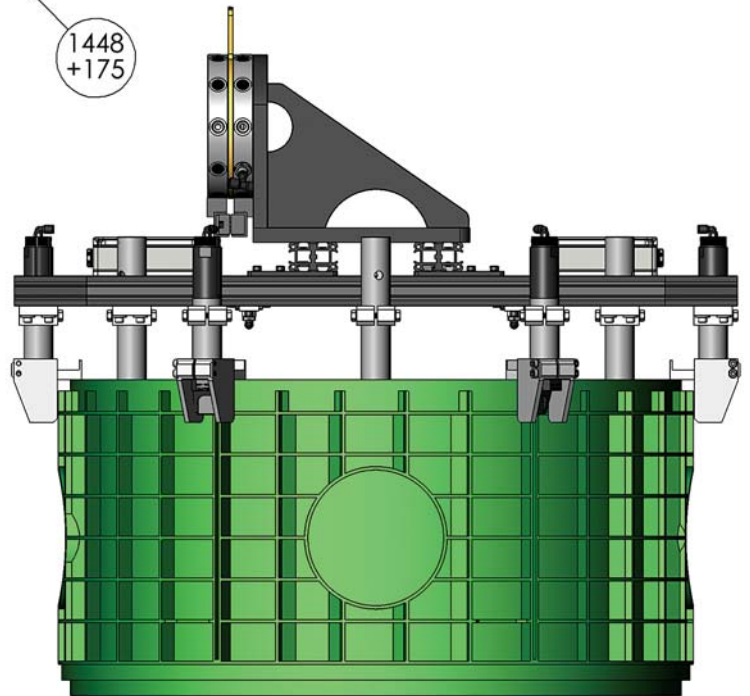
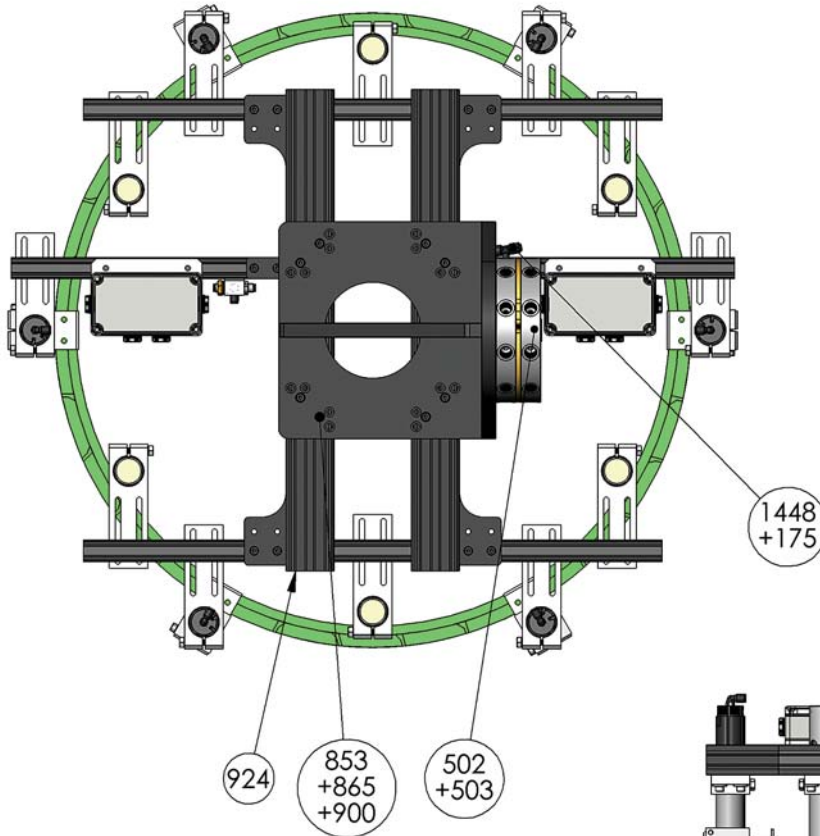

Using centering pins in combination with vacuum cups to provide part stability

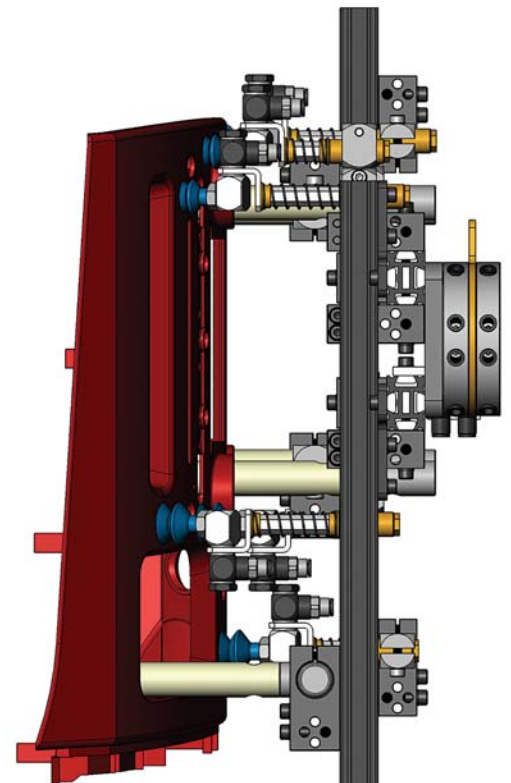
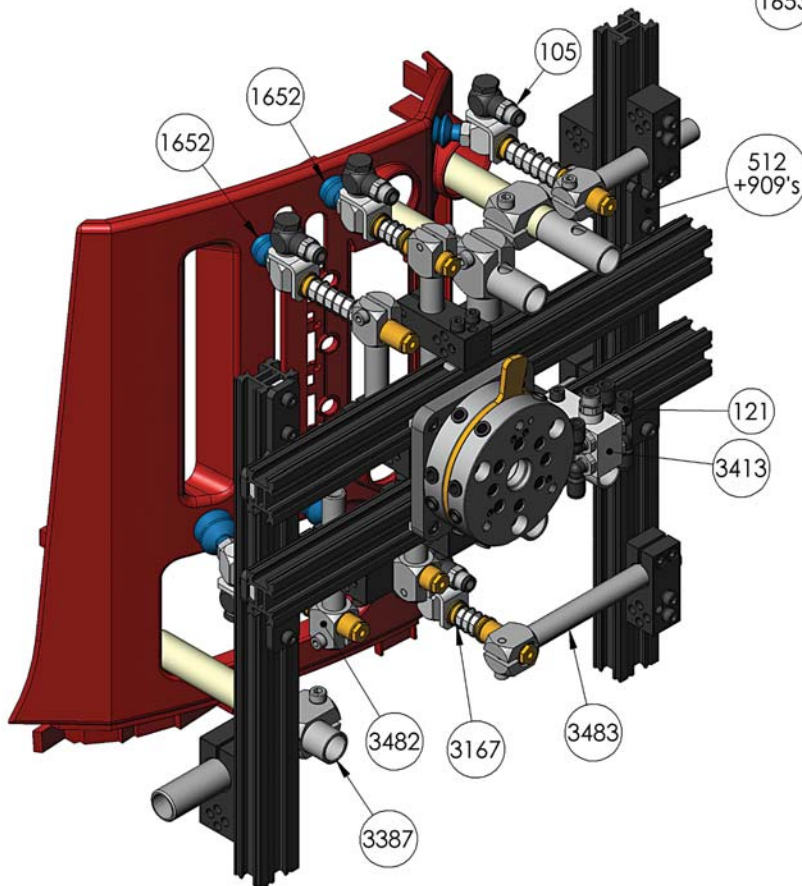
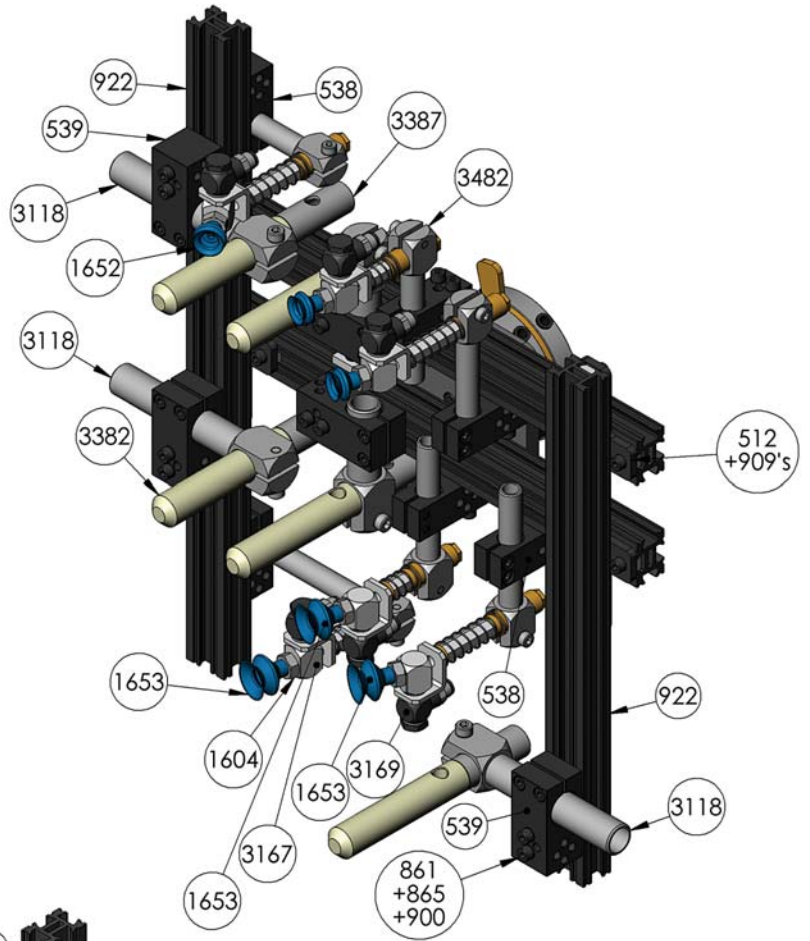

Using centering pins in combination with vacuum cups to provide part stability

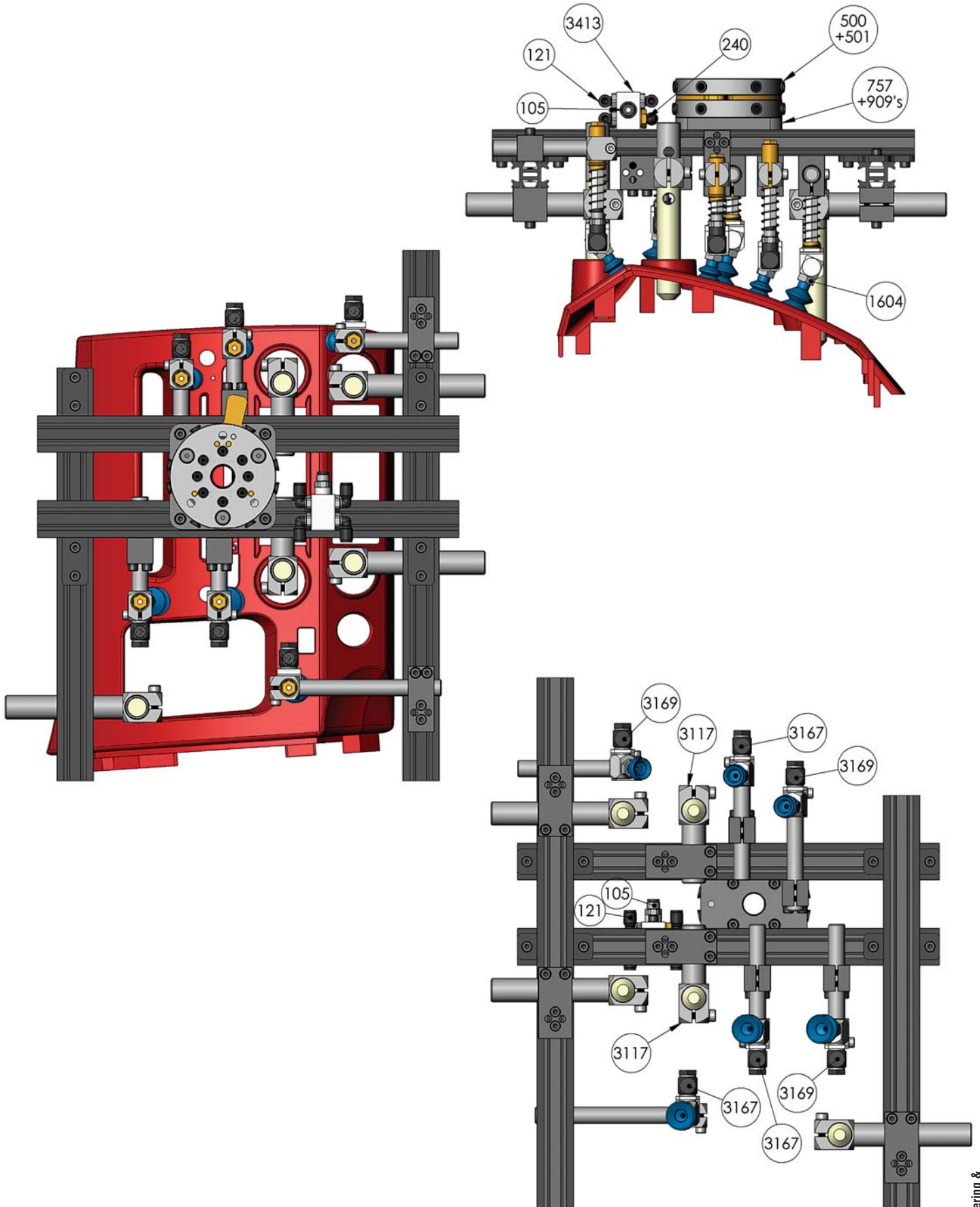

Degating using grippers to 'snap' parts from runners

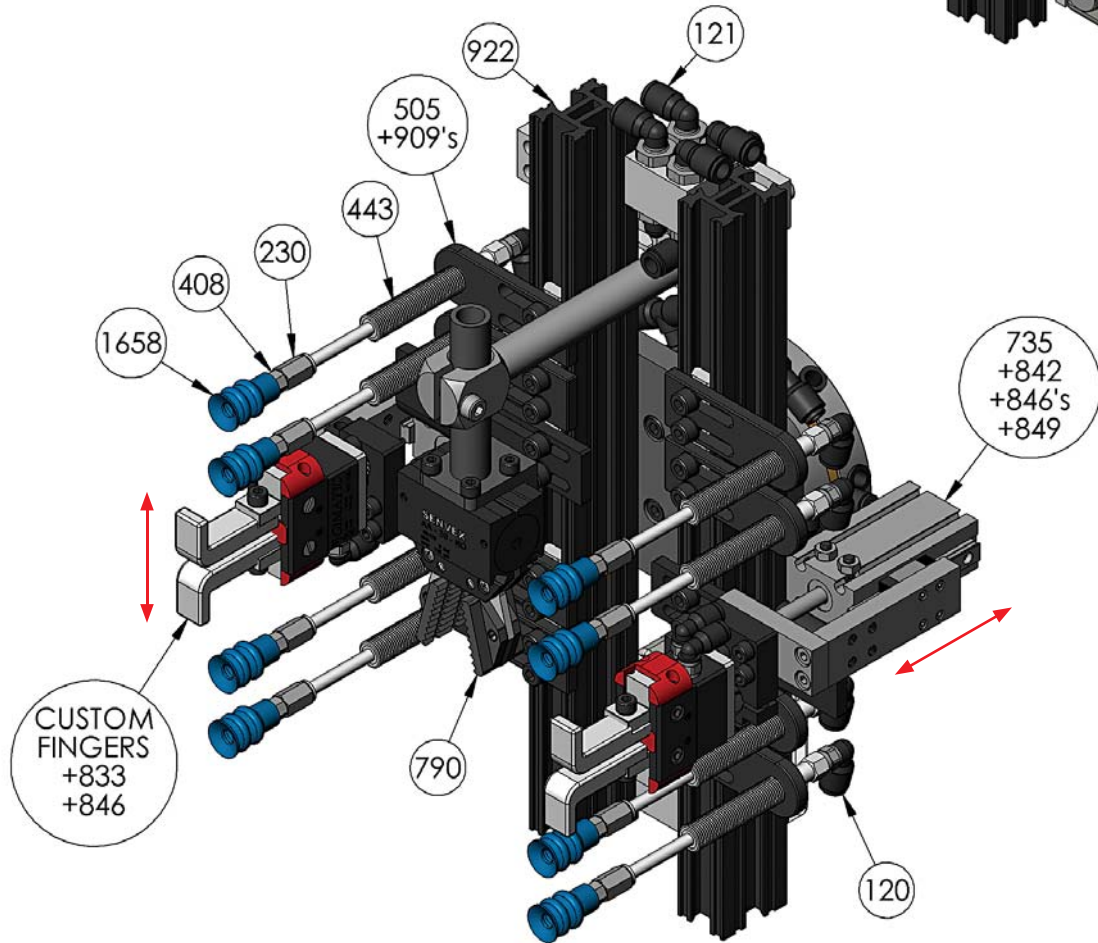
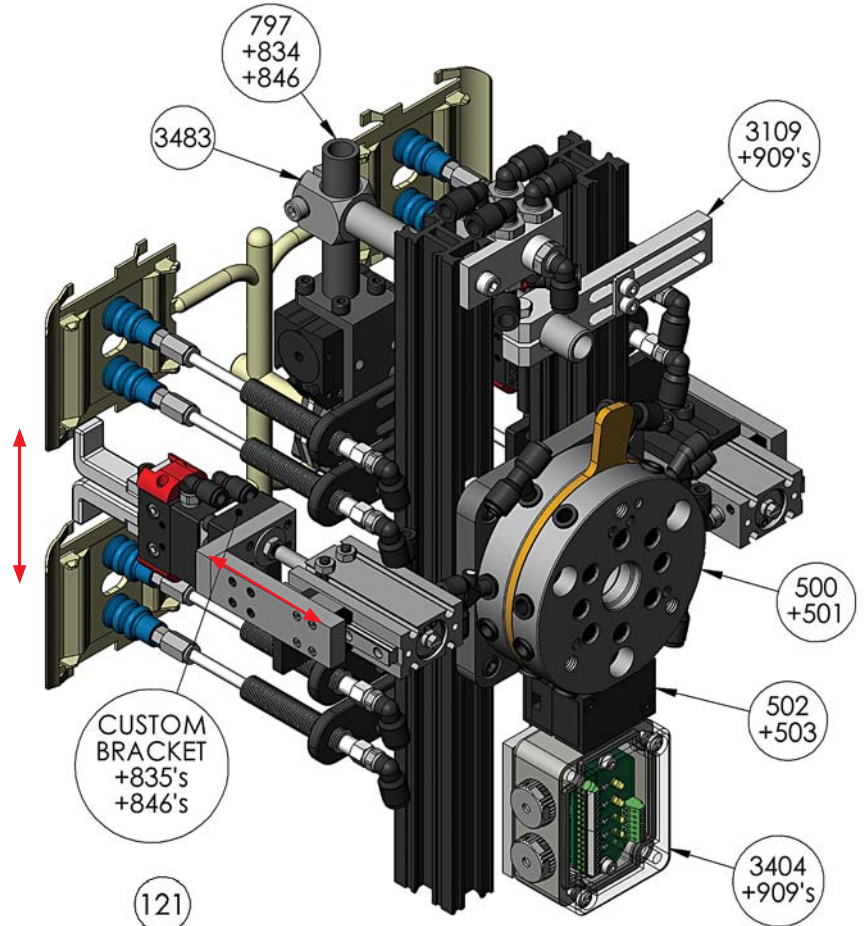
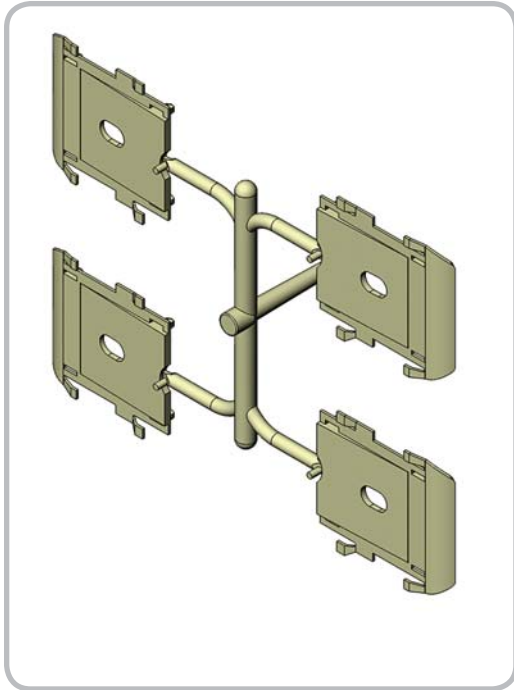

Degating using grippers to 'snap' parts from runners

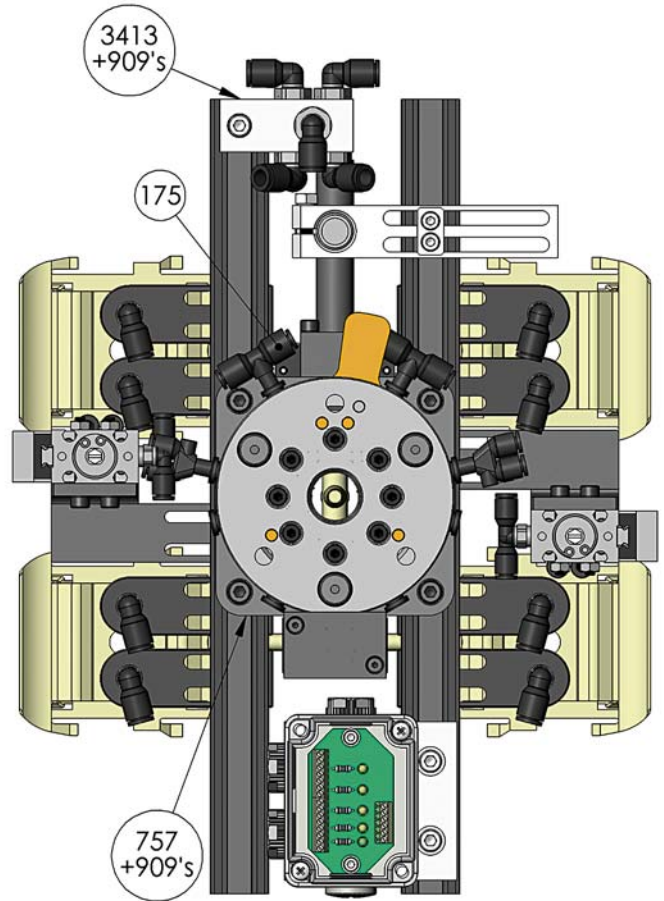
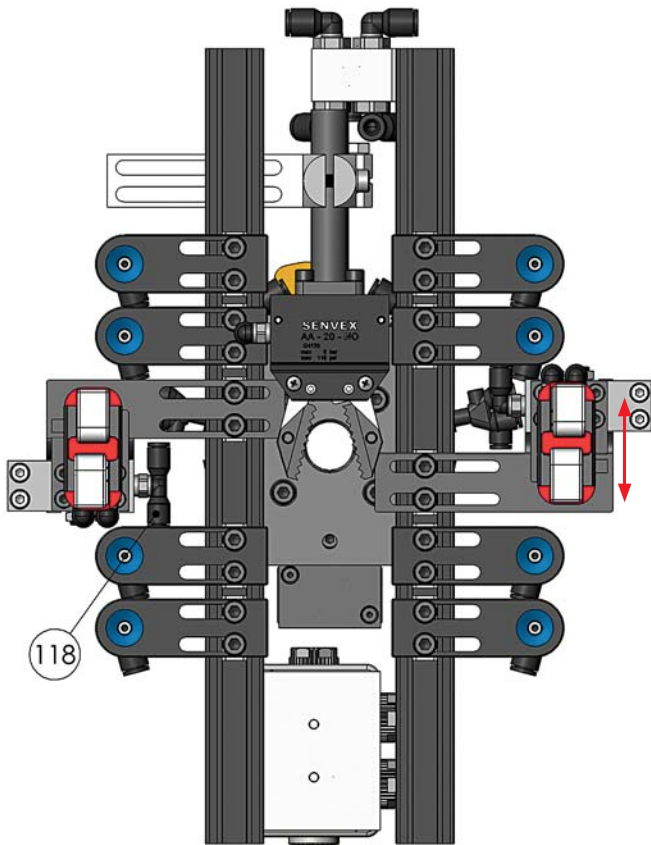
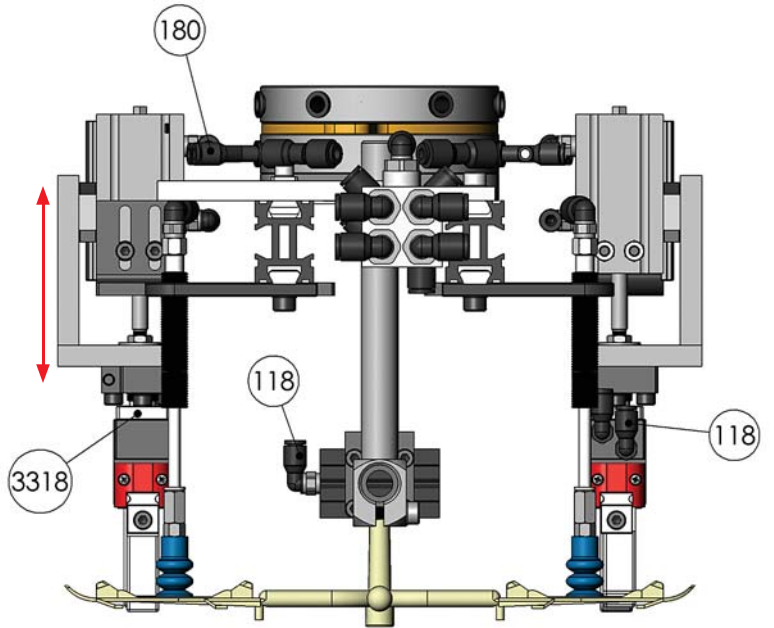
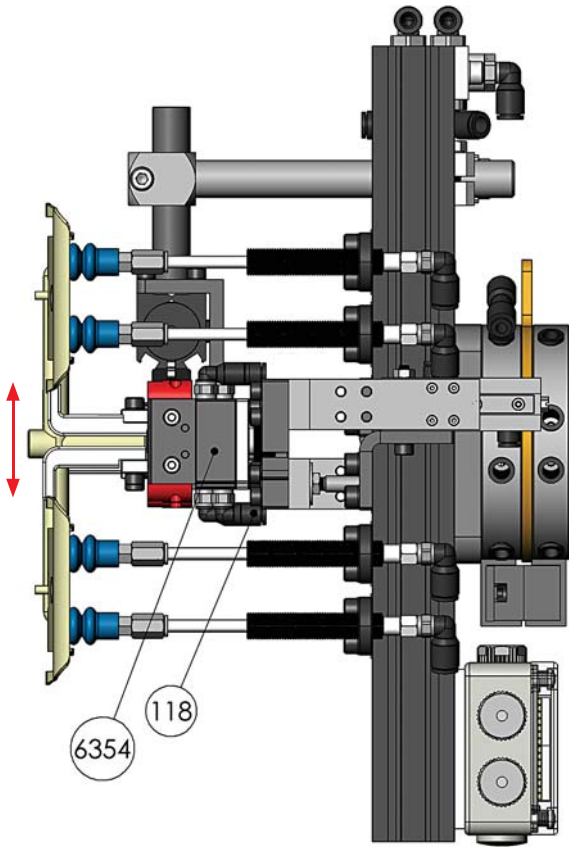

Degating on the EOAT

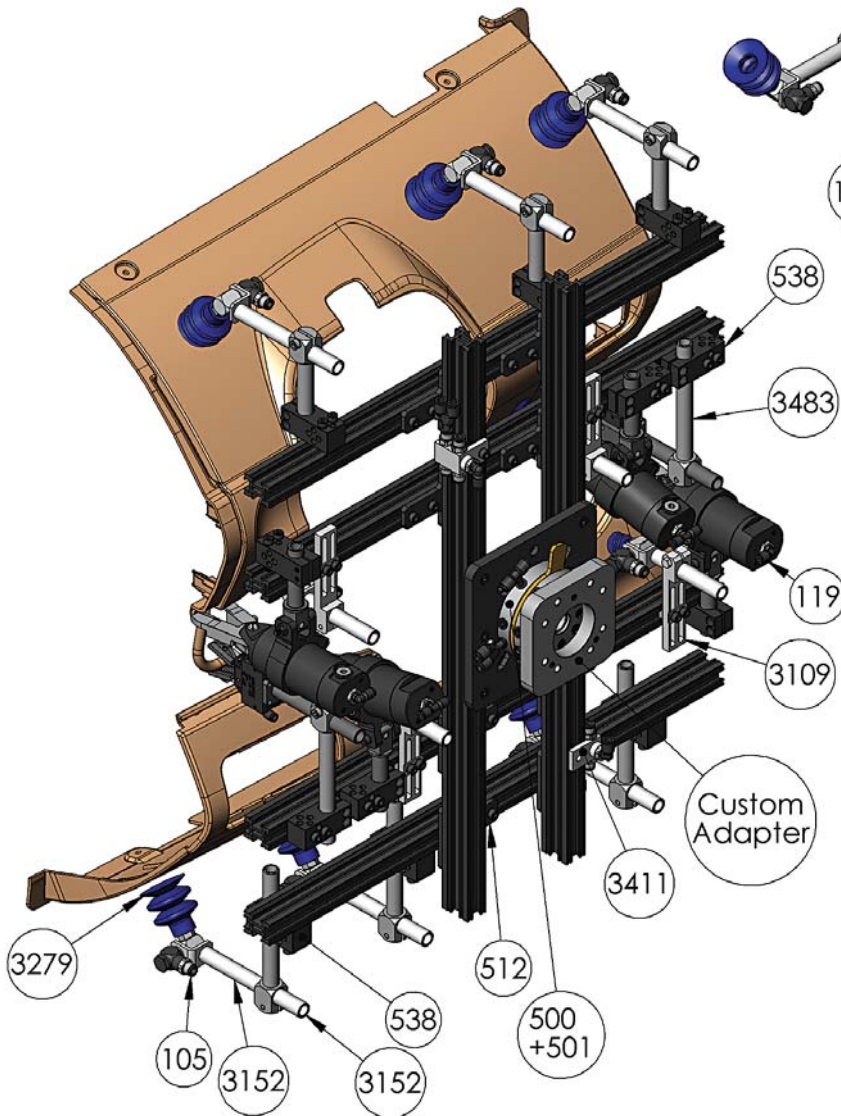
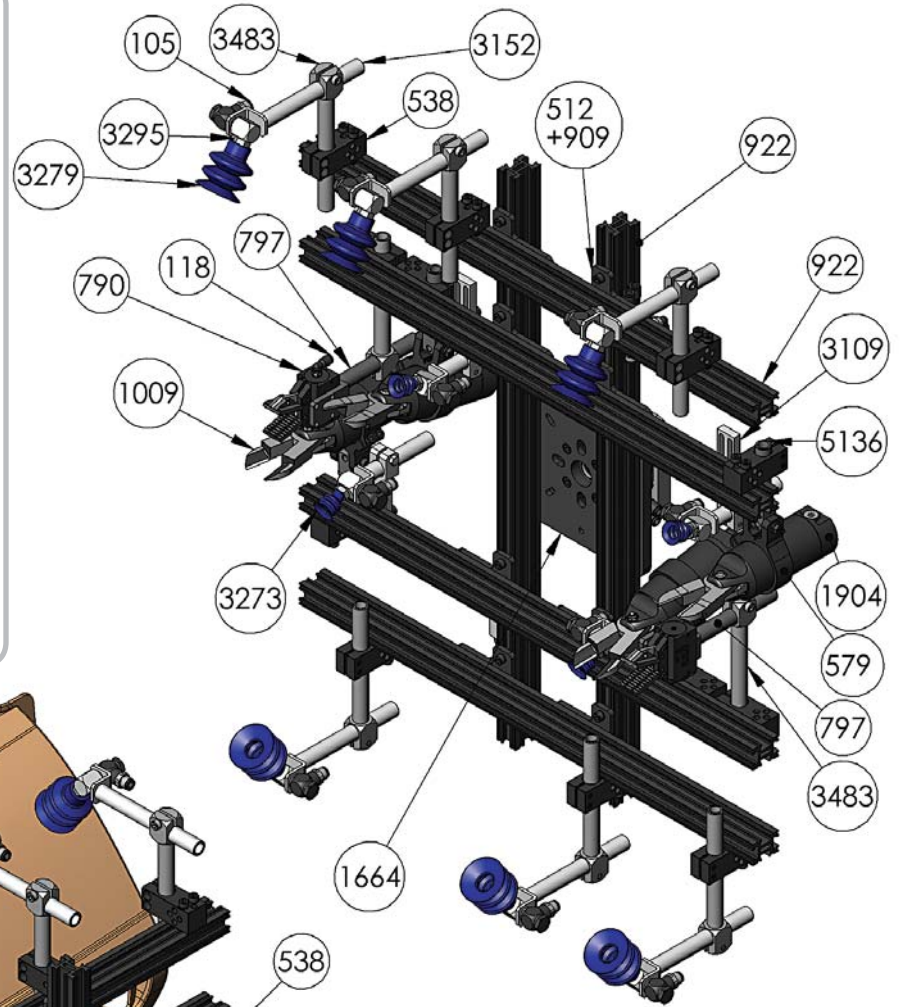
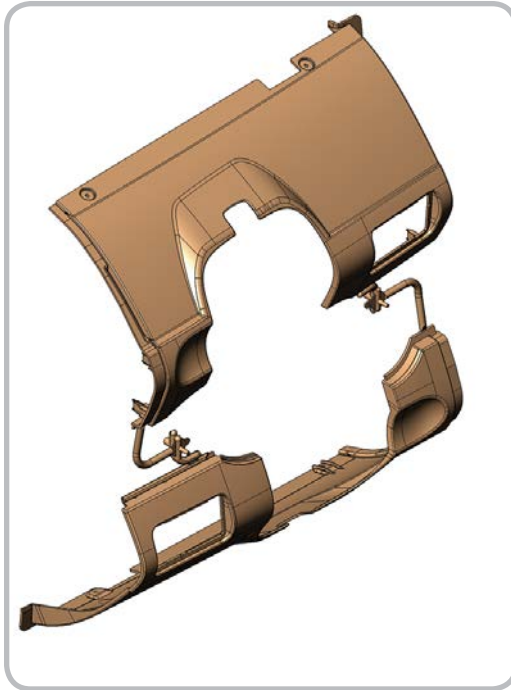

Degating on the EOAT

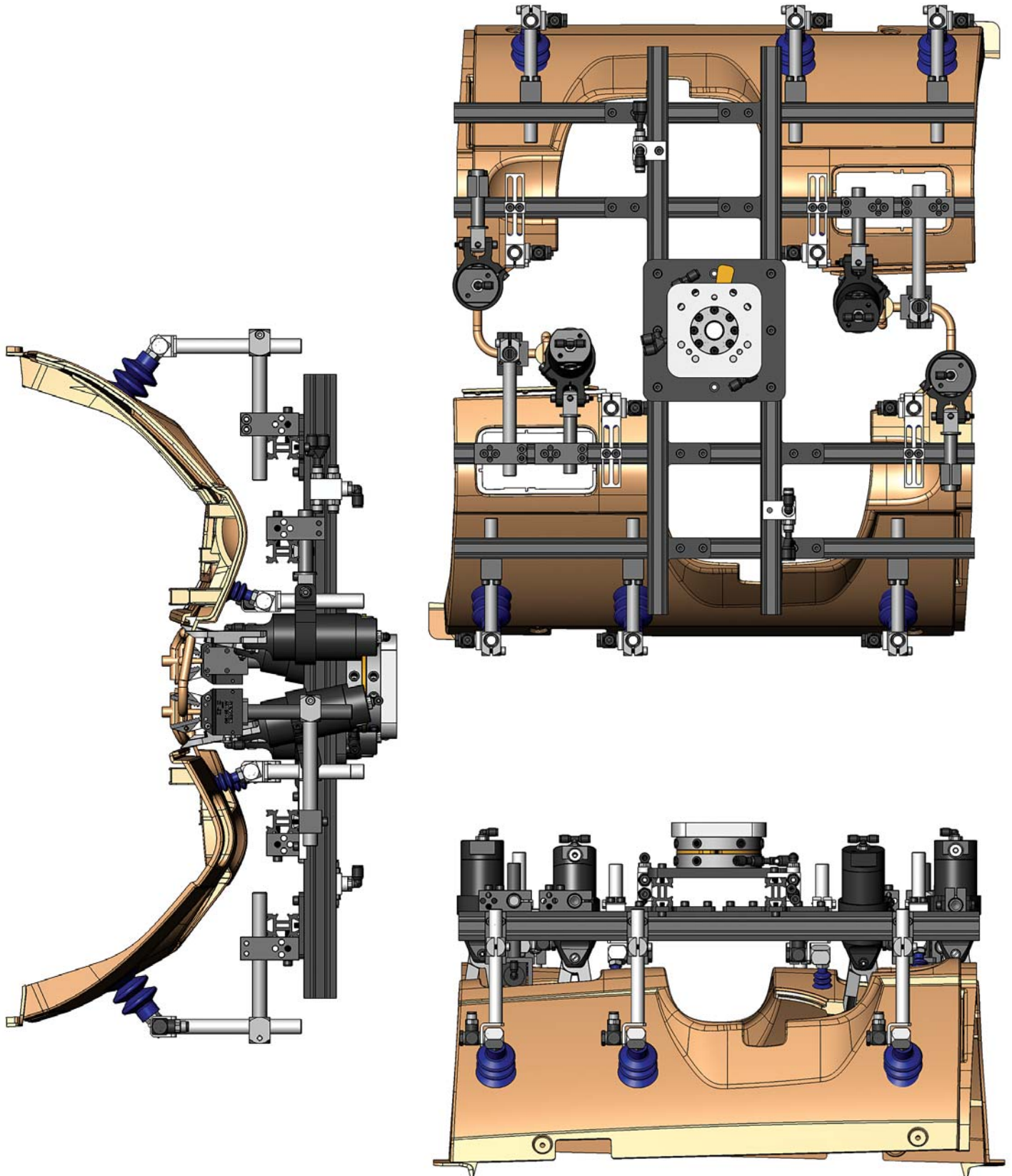

EOAT with 6-axis adaptor and quick changer

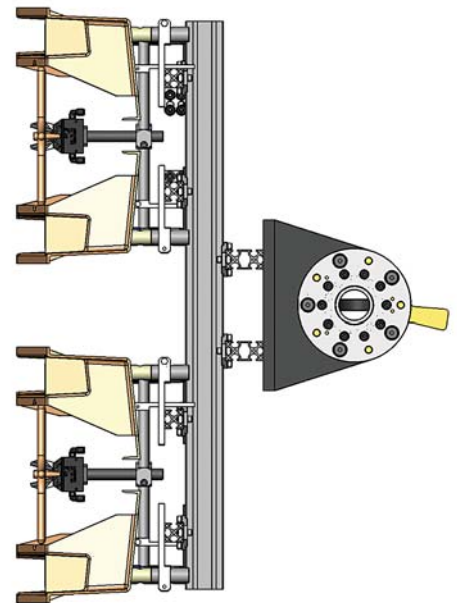
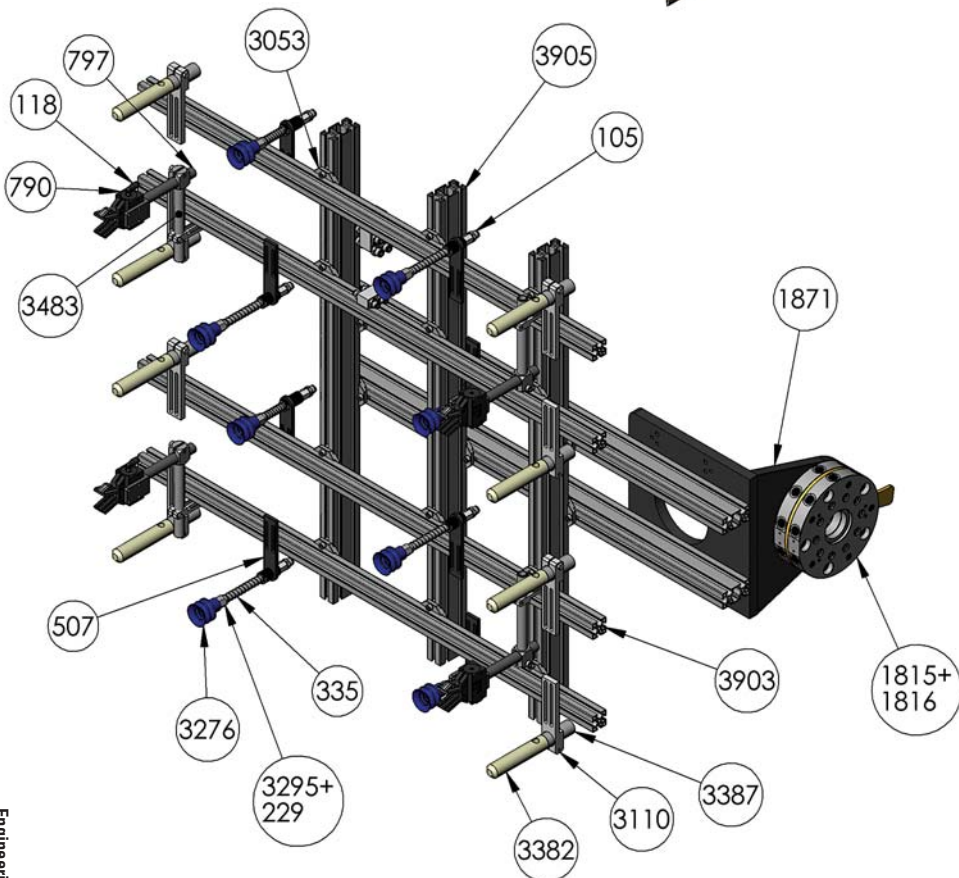
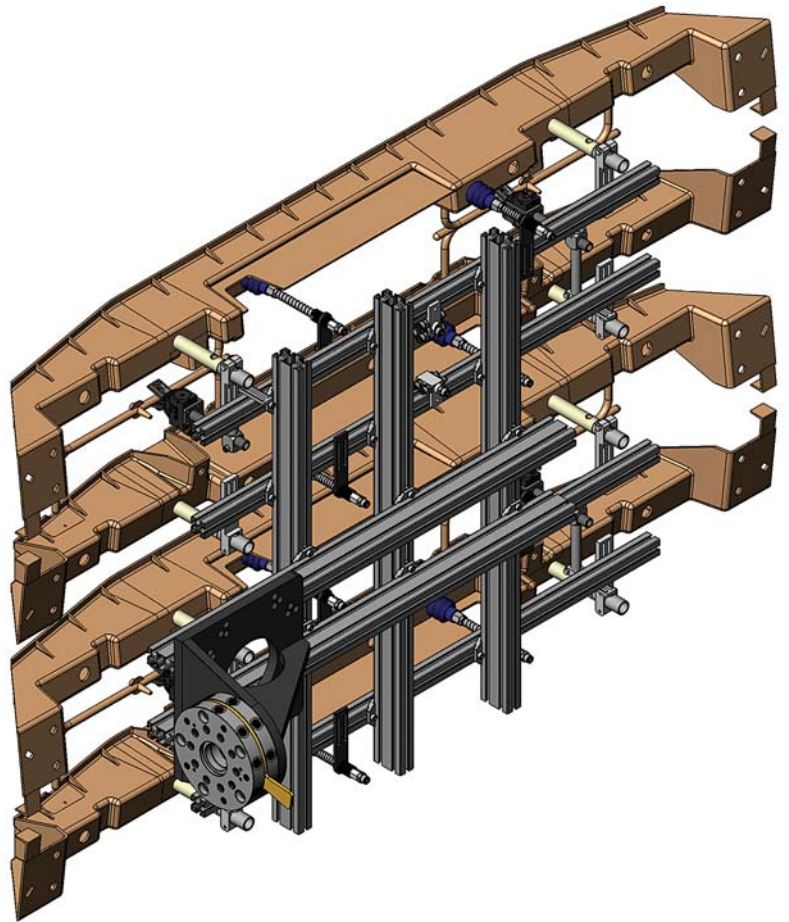

EOAT with 6-axis adaptor and quick changer

