

Angular Gripper – AA

(Dimensioned drawings shown full scale)

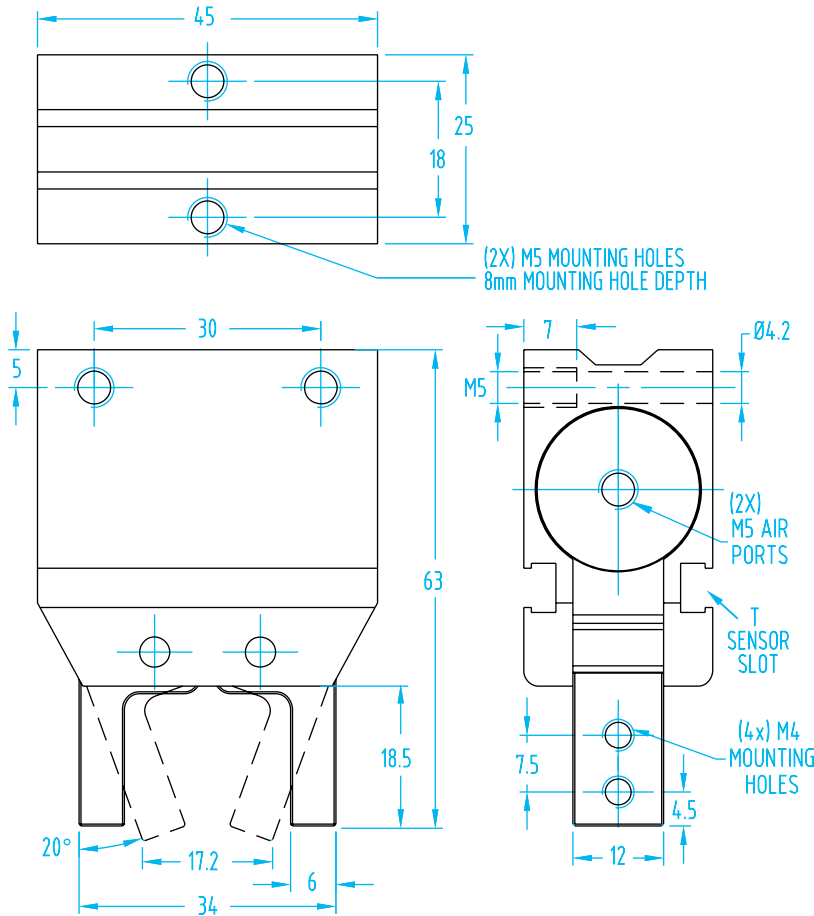

- This is the same gripper body as the #1473 and #1474 sprue grippers. It has excellent grip force, dual sensor grooves, and jaws with M4 threads to mount your own fingers.
- Mounting Brackets available on page 458–459.



AA-23 - Angular Gripper

Quick#	Part#	Price	Weight	Style	lbs. Force at 25mm Tooling Length*	lbs. Force at 35mm Tooling Length*
1753	GSG-AA-23-NO	\$205.00	102g	Spring Open	22.5 lbf	16.0 lbf
1754	GSG-AA-23	\$205.00	100g	Double Acting	27.0 lbf	19.5 lbf
<i>Order sensors separately</i>						
792	SL4N225G	\$27.20	PNP	T-slot, 3-wire with lead, 2.5m long		
6274	SL3N203G	\$31.16	PNP	T-slot, 3-wire with M8 male connector, 0.3m long*		
793	SL4M225G	\$27.20	NPN	T-slot, 3-wire with lead, 2.5m long		
6456	SL3M203G	\$31.16	NPN	T-slot, 3-wire with M8 male connector, 0.3m long*		

* Force when compressed air is supplied at 87psi. Tooling length is measured from jaw pivot point.

See Sensor Reference Guide on page 1010 for a complete list of compatible sensors.

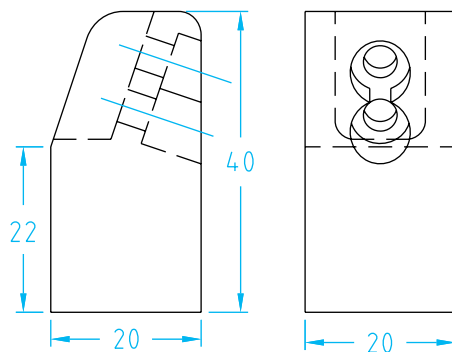
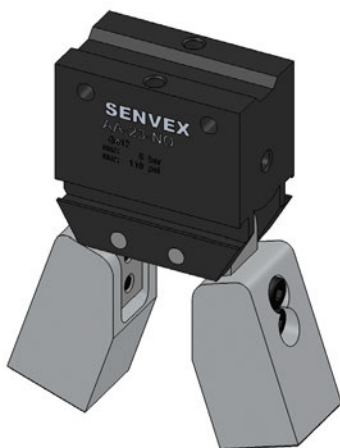

Don't want to machine custom fingers from scratch? Start with these aluminum finger blanks. They are easy to shape to your particular part.

AA-23 - Finger Blanks - priced per pair

Quick#	Part#	Material	Price
1859	GSG-FB-AA23	Aluminum	\$29.76

Includes fasteners.