

## Three-Jaw Electric Grippers – MPTM

- Self-centering jaw system (patented).
- 3-jaw parallel jaw movement.
- T-slot style jaws for heavy loads.
- Optional Gimatic C-slot sensors on page 1002.
- Cables for direct connection to cobots on page 181.



Quick#	6992	6993	6994
Part#	MPTM1606	MPTM2508	MPTM3210
Price	\$1,059.00	\$1,126.00	\$1,193.00
Total gripping force	11 lbf	22 lbf	54 lbf
Stroke	3x3mm	3x4mm	3x5mm
Max frequency	0.95 Hz	0.83 Hz	0.85 Hz
Jaw closing time	0.08s	0.12s	0.16s
Working gripper time	0.19s	0.31s	0.26s
Duty cycle	36%	52%	44%
Peak current	0.9 A	1.2 A	3.8 A
Brushless motor power	6W	11W	23W
Noise level		<70dB	
Weight (motor included)	183g	430g	693g
Environmental Degree		IP54	

Use Quick#s for easy online ordering.

### Continuous Flex Cables

Quick#	Part#	Description	Price
7160	CFGM800325P	2.5m cable 3-Wire with Straight M8 Connector	\$13.00
7161	CFGM890325P	2.5m cable 3-Wire with 90° M8 Connector	\$13.00

# Three-Jaw Electric Grippers – MPTM

### Reference

1. Sensor C-slot - Use Gimatic SS & SN sensors
2. Through hole for gripper fastening
3. Electric connection
4. Centering sleeves

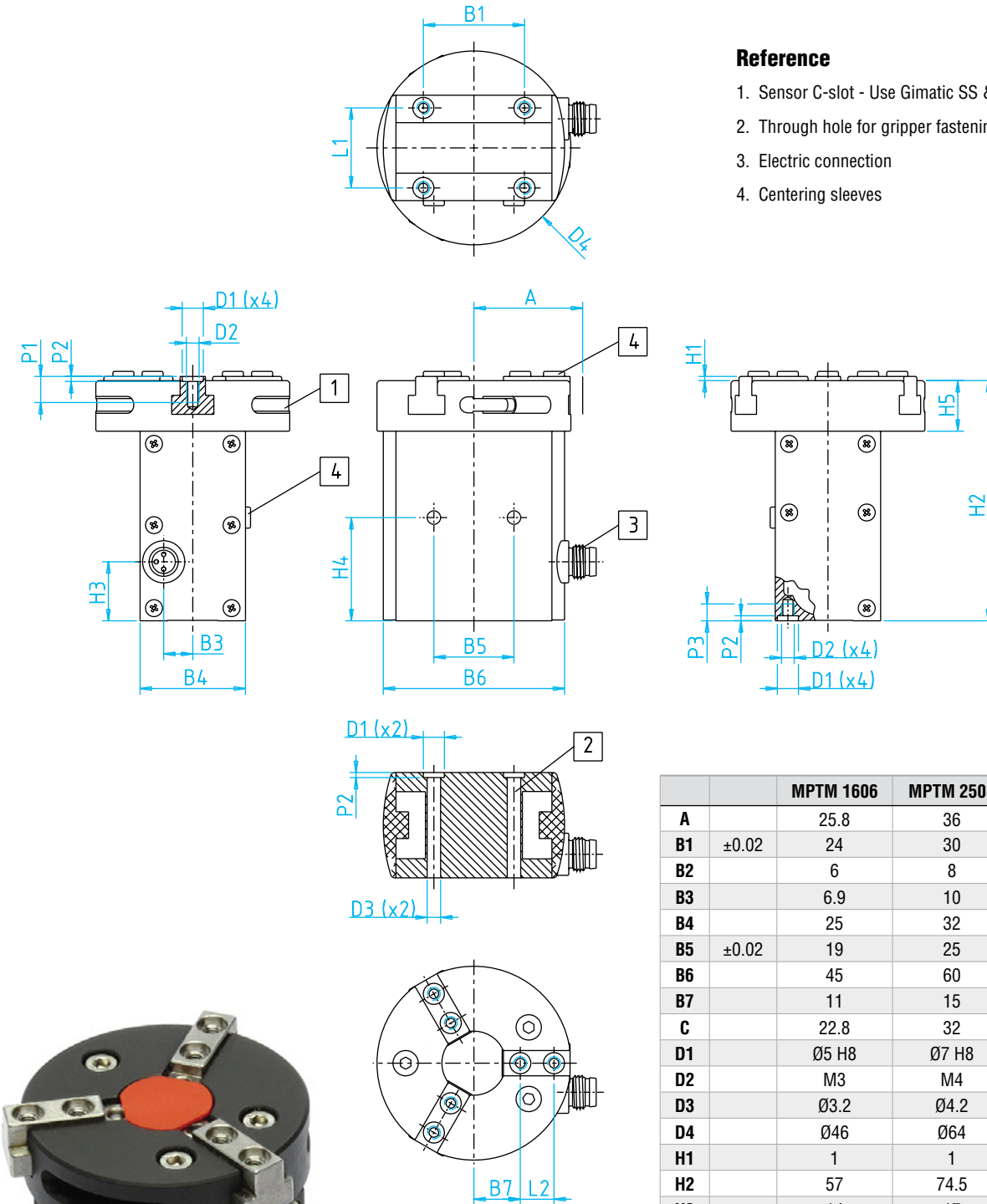

	MPTM 1606	MPTM 2508	MPTM 3210
<b>A</b>	25.8	36	44
<b>B1</b>	±0.02 24	30	36
<b>B2</b>	6	8	9
<b>B3</b>	6.9	10	11
<b>B4</b>	25	32	35
<b>B5</b>	±0.02 19	25	30
<b>B6</b>	45	60	73
<b>B7</b>	11	15	18.5
<b>C</b>	22.8	32	39
<b>D1</b>	Ø5 H8	Ø7 H8	Ø7 H8
<b>D2</b>	M3	M4	M5
<b>D3</b>	Ø3.2	Ø4.2	Ø5.2
<b>D4</b>	Ø46	Ø64	Ø78
<b>H1</b>	1	1	1
<b>H2</b>	57	74.5	85.5
<b>H3</b>	14	17	19
<b>H4</b>	±0.02 24.5	32	38
<b>H5</b>	12	15	17
<b>L1</b>	±0.02 19	24	26
<b>L2</b>	±0.02 8	12	14
<b>P1</b>	6.2	8	8.5
<b>P2</b>	+0.1 1.2	1.5	1.5
<b>P3</b>	4	6	8