

Compact-Body Sensor Sprue Gripper – DD20-16

(Dimensioned drawing shown full scale)

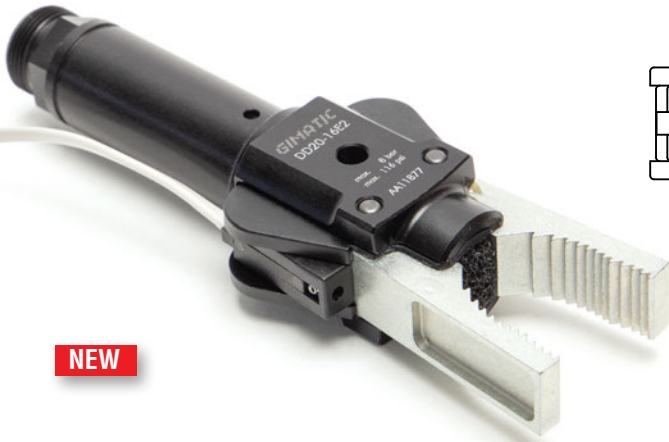

NEW

- New Sensor Slot position provides sensing without interfering with the part being gripped.
- Angular, self-centering.
- Gripper has a G1/8" air port.
- Higher grip force than GRZ20-16 grippers.
- Clampable along full length of Ø20mm body.
- Diamond-textured fingers provide excellent gripping of small to large sprues. This design is also excellent for sprues that need to be pulled or stripped from a mold cavity.
- 20mm diameter mounting body allows this gripper to be used with standard mounting components.
- Replacement parts available online.

SET-UP NOTE: The sensor will only send a signal when the gripper is actuated with compressed air.

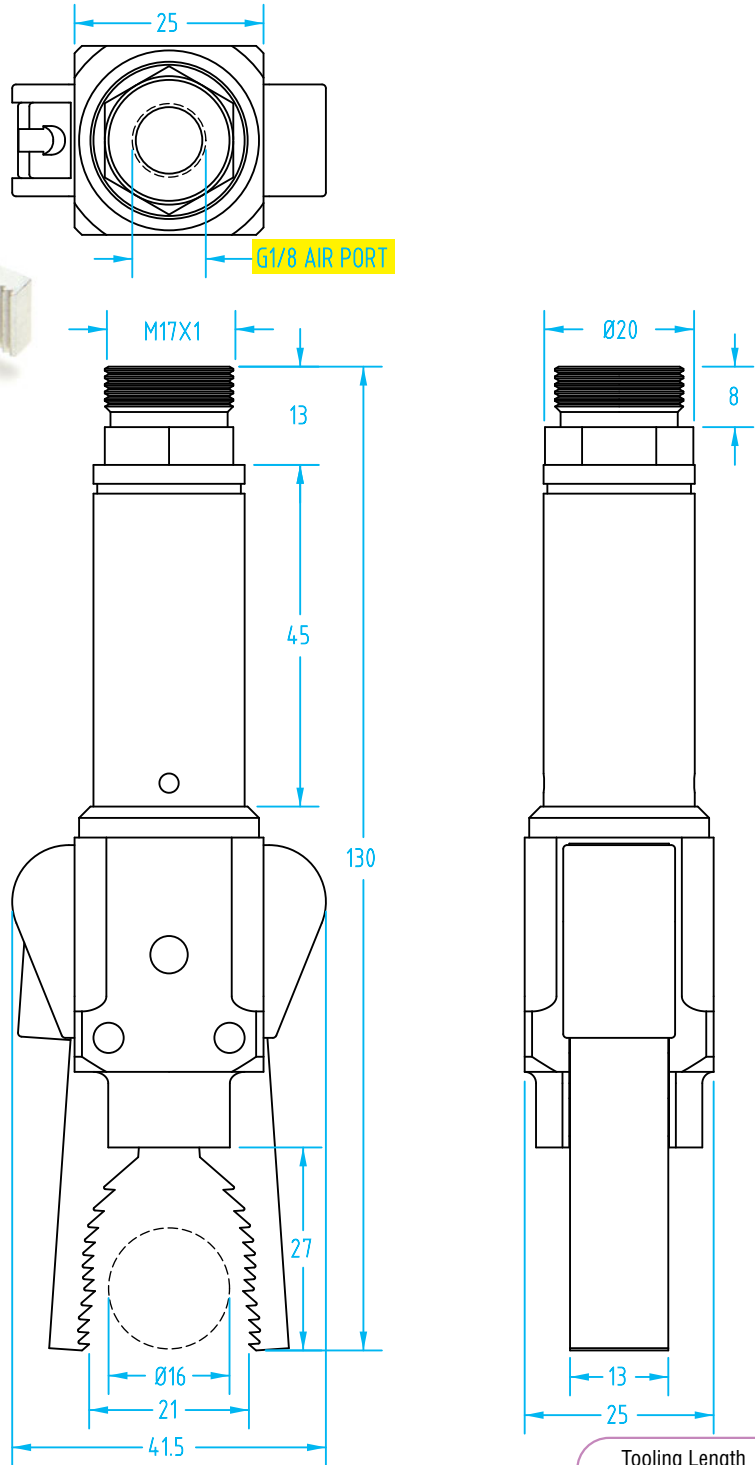

Quick#	Part#	Price	Style	Applicable Sprue Ø	Ibs. Force at 30mm Tooling Length*	Weight
7554	DD20-16E2	\$179.00	Concave Diamond Texture	3–12mm	45.0 lbf	138g
Order sensors separately See Sensor Reference Guide on page 1008 for a complete list of sensors for DD Grippers.						
1882	SS4N225G	\$27.20	PNP sensor	with lead, 2.5m long		6–30 Vdc
6282	SS3N203G	\$31.16	PNP sensor	M8 male connector, 0.3m long**		6–30 Vdc
1883	SS4M225G	\$27.20	NPN sensor	with lead, 2.5m long		6–30 Vdc
1884	SS3M203G	\$31.16	NPN sensor	M8 male connector, 0.3m long**		6–30 Vdc

Note: 2-wire reed sensors are not recommended for grippers.

* The Closing Force listed is both jaws combined when supplied at 87psi. Tooling length is measured from jaw pivot point.

** M8 Extension cables Quick#'s 2582 & 2583 available on page 985.

