

Mini Sprue Gripper with Custom Jaws – PB-0017

(Dimensioned drawings shown full scale)

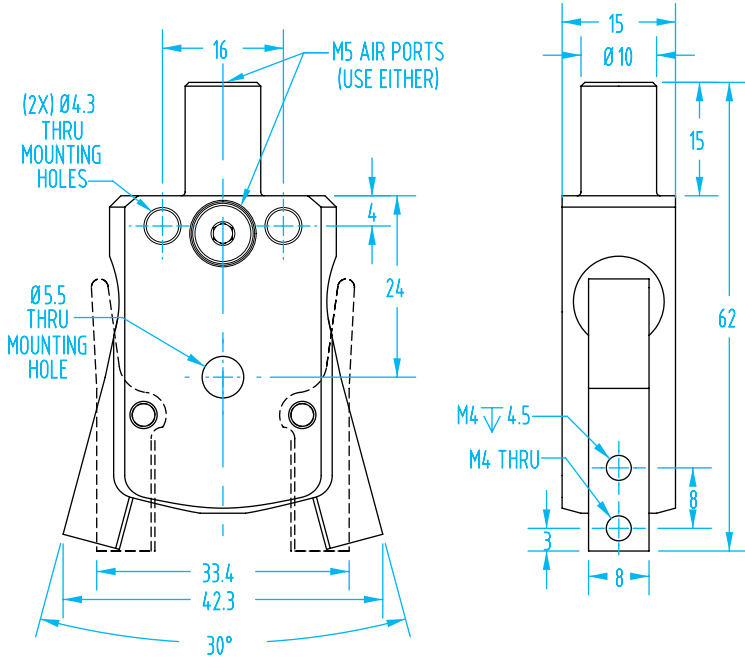

- Single-acting with protected opening spring.
- Higher grip force than other similarly sized sprue grippers.
- Angular, non-self-centering.
- Ø10mm diameter mounting post with M5 air port allows this gripper to be used with standard mounting and air connection components. Alternate M5 air port on front of gripper can be used.
- Replacement parts available online.

| Quick# | Part# | Price | Style | Closing Force at 25mm Tooling Length* | Weight |
|--------|---------|----------|-----------------|---------------------------------------|--------|
| 7116 | PB-0017 | \$121.00 | For custom jaws | 11.0 lbf | 45g |

* The Closing Force listed is both jaws combined when supplied at 87psi. Tooling length is measured from jaw pivot point.



#1236

Finger Blanks - priced per PAIR

| Quick# | Part# | Description | Price |
|--------|-------------|----------------------|---------|
| 1236 | PB-0017-FBA | Aluminum, 15mm thick | \$21.83 |
| 1237 | PB-0017-FBP | Acetal, 15mm thick | \$21.83 |

Includes fasteners.

Gripper shown fully open:

- Part to be gripped (example)
- Material to be machined away (example)

Gripper shown fully closed:

- Overlapping area when gripper is fully closed



Example Custom Finger

