

Suction cups / Polyurethane

VG.MF30P flat suction cup with non-slip tread pattern in polyurethane

- Ideal for handling oiled sheet metal in stamping processes
- Special tread pattern that increases friction on lubricated surfaces
- Excellent stability

Introduction

Vacuum theory

Suction cups



Application example

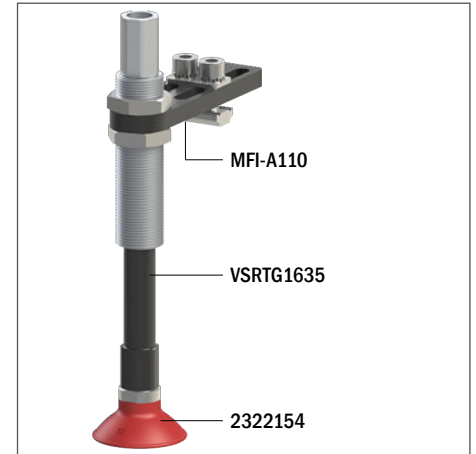

Vacuum pumps

Customised solutions

Suspensions

System accessories

Technical data

Material	Lifting force [N] perpendicular to the surface, at various vacuum levels			Lifting force [N] parallel to the surface, at various vacuum levels			Volume [cm ³]	Min curve radius [mm]	Max vertical movement [mm]	Suction cup weight [g]
	-20 kPa	-60 kPa	-90 kPa	-20 kPa	-60 kPa	-90 kPa				
PU40	10	33	48	26	40	49	4.8	30	5.3	2.3

Technical features

Material	Color	Hardness	Temperature range
Polyurethane PU40 Shore	Red	40 Shore	+50 - +113 °F

Identification codes

Drawing	Alphanumeric code	Suction cups with fitting	Order code
A	VG.MF30P.40.G18M	VG.MF30 suction cup, polyurethane, 40 Shore, G1/8" male	2322154
B	VG.MF30P.40.G18F	VG.MF30 suction cup, polyurethane, 40 Shore, G1/8" female	2322156

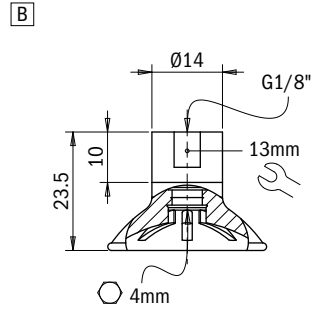
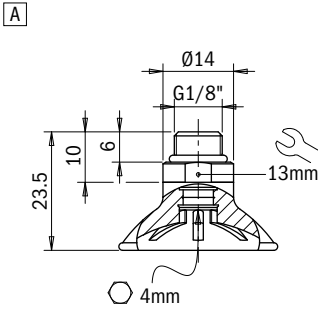

Identification codes

Drawing	Alphanumeric code	Suction cups	Order code
A	VG.MF30P.40	VG.MF30 suction cup, polyurethane, 40 Shore	2322155

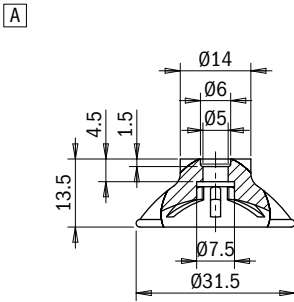

Identification codes

Drawing	Alphanumeric code	Fittings	Order code
A	FT.G18M.20	G1/8" male fitting	2000018
B	FT.G18F.20	G1/8" female fitting	2000019

