

## KIT-UR-V

End Of The Arm Tool (EOAT) for vacuum based pick & place operations. The system can be assembled on the UR3, UR5 or UR10 collaborative robots and the included pneumatic actuator and components allow for a direct connection to the robot wrist and to the pneumatic power source.

### Main features

- A unique design for UR3, UR5 and UR10.
- No electric cables along the robot arm: direct connection to M8 plug connector of the robot.
- Easy to install and without any configuration (plug & play solution).
- Embedded vacuum generator, valve and solenoid.

[Click for Pricing & Add to Cart](#)

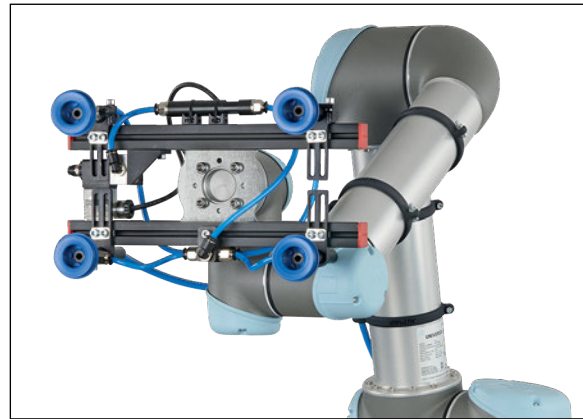

### How does it work?

Mount the system with the included mechanical flange to the wrist of the robot and connect the main valve inlet to the pneumatic power source. The system can be electrically connected directly to the M8 plug connector at the wrist of the robot (not cables along the robot arm). The system can be operated via digital output from the tool interface of the UR robot.

### Dimensions (mm)

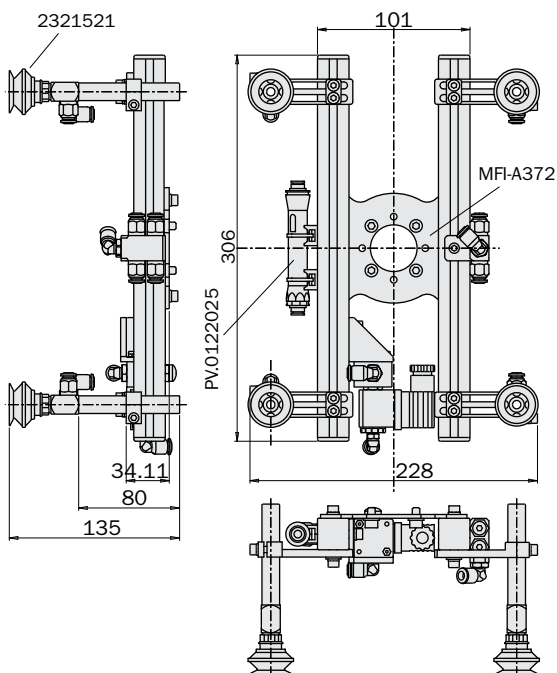

### Adjustments (mm)

