

One finger, perpendicular acting, pneumatic grippers for clamping, series OFX

- Single-acting pneumatic piston drive.
- Finger linear motion, perpendicular to the piston.
- Finger with through hole, to provide vacuum to a cup (1).
- Removable HNBR rubber pad (2) on the finger, for a soft touch.
- Optional sensors and clamps (3).
- FDA-H1 food-grade grease.

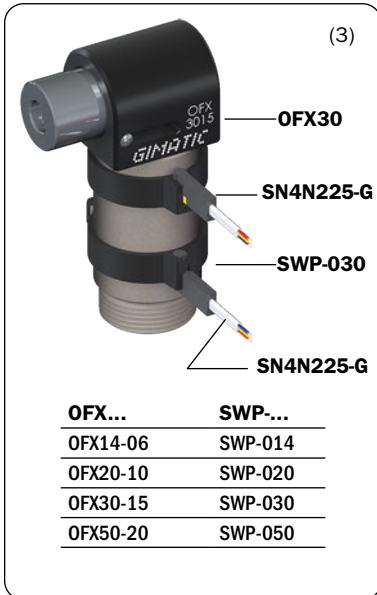

	OFX14-06	OFX20-10	OFX30-15	OFX50-20
Medium	Compressed air in compliance with ISO 8573-1:2010 [7:4:4]			
Pressure range	2.5 ÷ 8 bar			
Temperature range	5° ÷ 60 °C.			
Opening gripping force at 6 bar	13 ÷ 63 N	20 ÷ 115 N	44 ÷ 230 N	100 ÷ 900 N
Total stroke	6 mm	10 mm	15 mm	20 mm
Maximum working frequency	1 Hz	1 Hz	1 Hz	1 Hz
Cycle air consumption	0.5 cm ³	3.5 cm ³	15 cm ³	50 cm ³
Weight	30 g	65 g	190 g	740 g

Dimensions (mm)

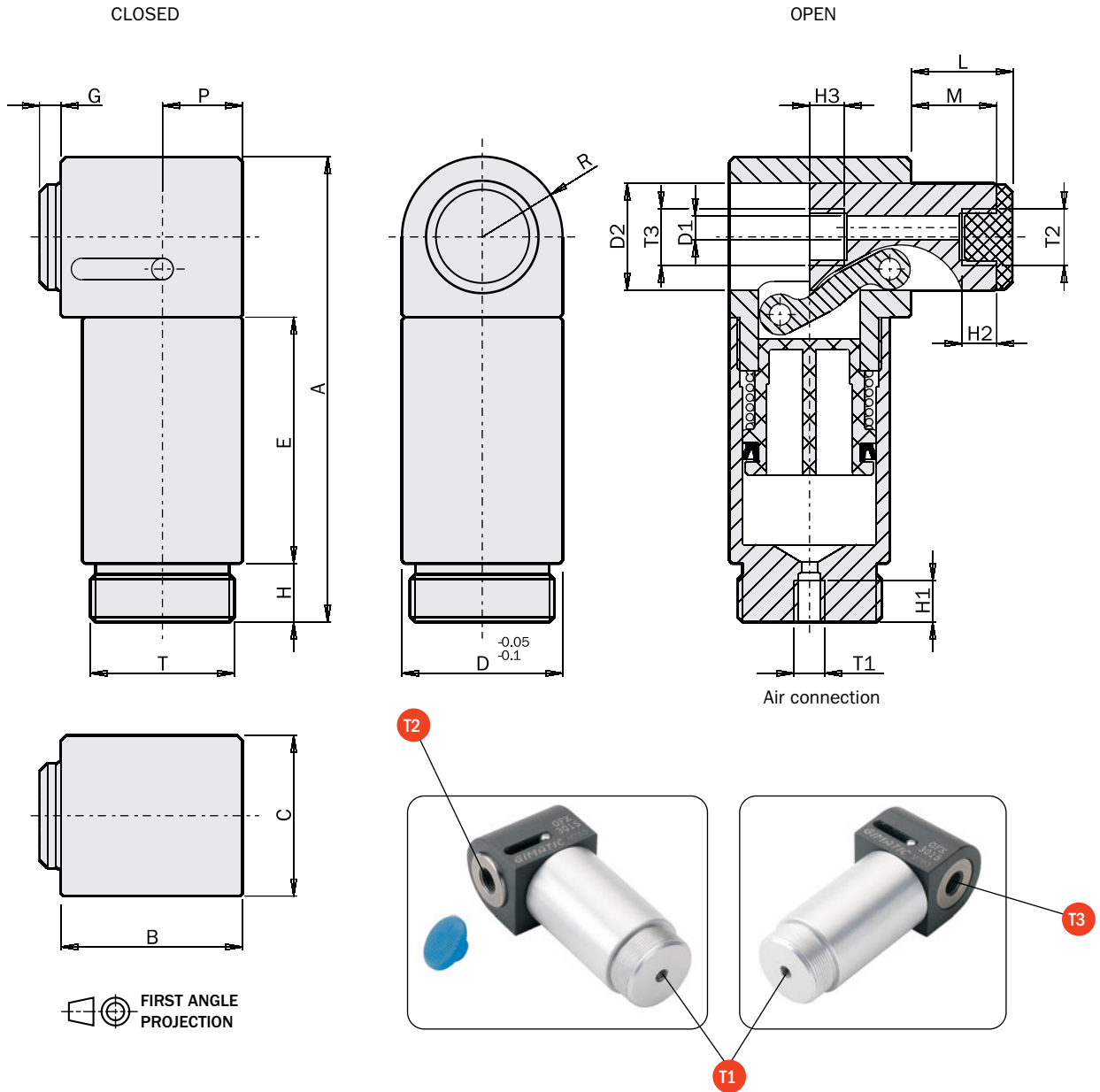

	OFX14-06	OFX20-10	OFX30-15	OFX50-20
A	52	62.5	87	143
B	23	25	34	60
C	14	20	30	50
D	Ø14	Ø20	Ø30	Ø50
D1	Ø1.5	Ø2.4	Ø4.5	Ø9
D2	Ø10	Ø14	Ø20	Ø35
E	30	34.5	46	68
G	3.5	3.5	4	4
H	8	8	11	25
H1	7	7	7	10
H2	5	5	6	9
H3	5	5	6	9
L	9.5	13.5	19	24
M	7	11	16	21
P	9	10	15	25
R	R7	R10	R15	R25
T	M12x1	M17x1	M27x1	M45x1.5
T1	M5	M5	M5	G1/8"
T2	M5	M5	G1/8"	G1/4"
T3	M5	M5	G1/8"	G1/4"