

Double stroke slide for large sprue grippers

- Double-effect main cylinder with piston bore 32mm and stroke 35mm.
- Single-acting intermediate stopper (1).
- Dia. 36mm clamp for GN-10 actuator (2).
- Used for car bumpers extracting.
- Optional magnetic sensors.
- Stroke reduction spacer included.

	ZJ-3235
Medium	Compressed air in compliance with ISO 8573-1:2010 [7:4:4]
Pressure range	2 ÷ 8 bar
Temperature range	5° ÷ 60 °C
Main stroke without spacer	35 mm
Intermediate stroke without spacer	10 ÷ 20 mm
Main stroke with spacer	25 mm
Intermediate stroke with spacer	0 ÷ 10 mm
Pulling force at 6 bar	450 N
Weight	1330 g

Dimensions (mm)

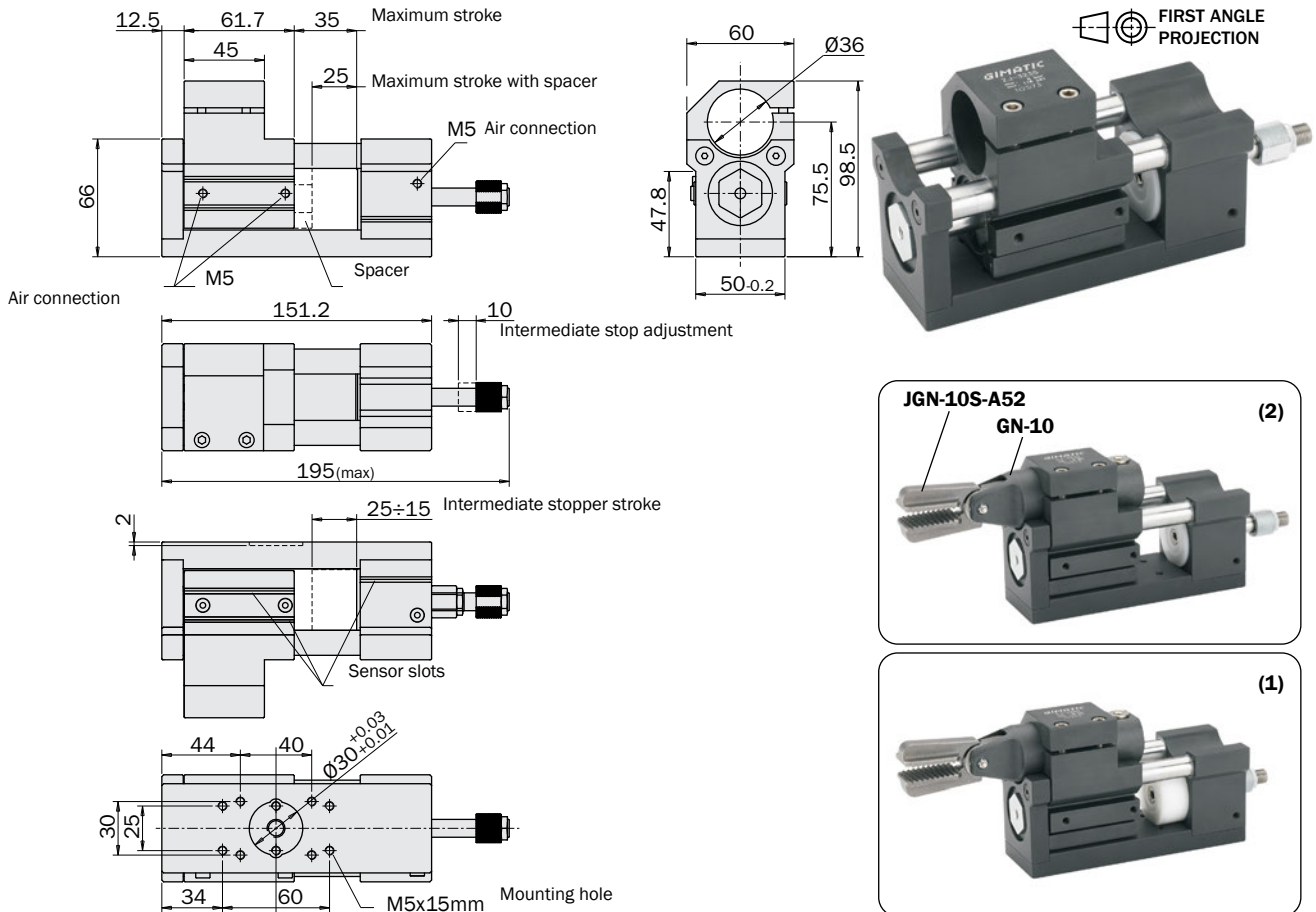

Application example

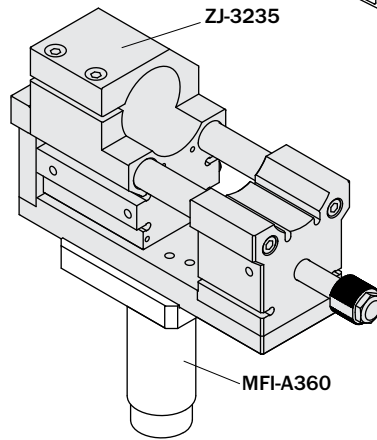
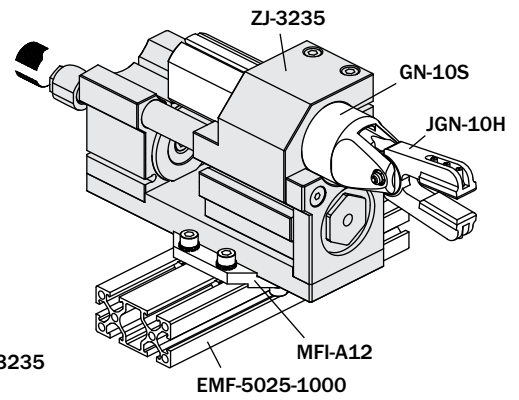
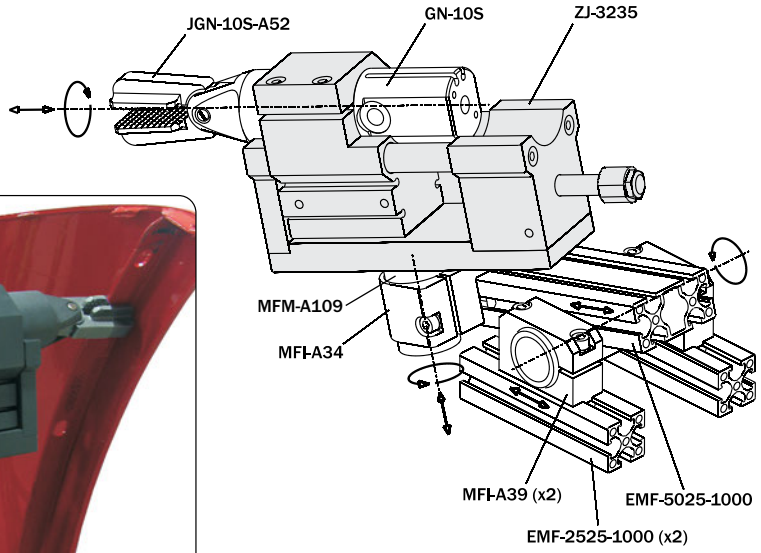
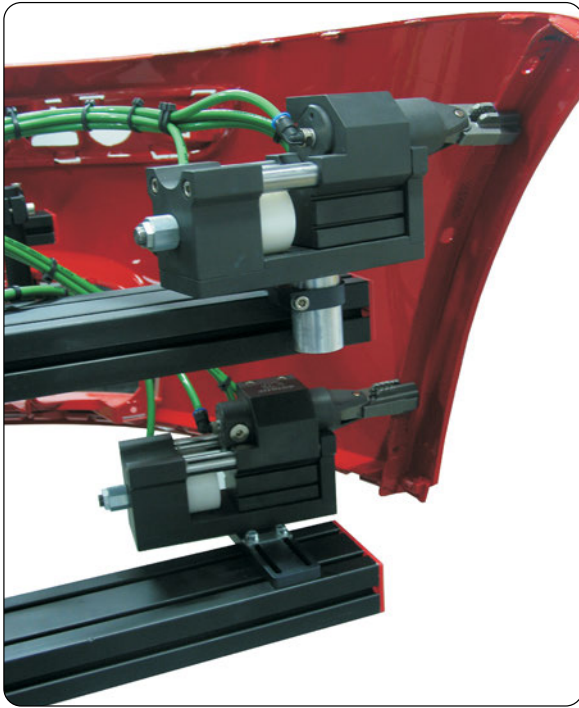

Spacer mounting

