



VACUUM
SOLUTIONS

2022



How to use this Gimatic from EMI Catalog:

Using this interactive catalog is easy - just like paging through the paper catalog – but with added benefits. Hotlinks in the table of contents and product sections make navigation easy and fast. You can also search by keyword or part number. Bookmark your favorite items, add comments, print, and share pages. Once you find the item you want, click the part number and an e-commerce pop-up will let you login and add items to your cart.



Clicking this logo on the right hand pages directs you back to the front index.

Clicking the side tabs direct you back to that section's index page.

Part description	Order code
Suction cup, silicone, 50 Shore, M5 female, 8 mm hex	2321662
Suction cup, silicone, 50 Shore, M5 male, 8 mm hex	2321664
Suction cup, silicone, 50 Shore, G1/8" female, 13 mm hex	2321665
Suction cup, silicone, 50 Shore, G1/8" male, 13 mm hex	2321666

C

D

Part description	Order code
Suction cups	2321663

Introduction

Vacuum theory

Suction cups

Pricing for all components that EMI offers are found online. Interactive links have been added that direct you to EMI e-commerce where you can add the item to your cart. Product pages include additional information, 360° views and CAD file downloads.

Identification codes			
Drawing	Alphanumeric code	Suction cups with fitting	Order code
A	VG.U16S.50.M5F.E8	VG.U16 suction cup, silicone, 50 Shore, M5 female, 8 mm hex	2321662
B	VG.U16S.50.M5M.E8	VG.U16 suction cup, silicone, 50 Shore, M5 male, 8 mm hex	2321664

Product Detail

V1412 Gimatic 16.2mm Silicone Flat Suction Cup with M5 Male Nipple, 8mm Hex
VG.U16S.50.M5M.E8

Item #: GOC 2321664
 \$5.84 Each

Quantity:

[Add To Cart](#)

[+ Supply List](#)

Available: In Stock
[Technical Specifications](#)
[CAD File Download](#)

Overview | Dimensional Drawing

Material	Lifting force [N] perpendicular to the surface, at various vacuum levels			Lifting force [N] parallel to the surface, at various vacuum levels			Volume [cm ³]	Min curve radius [mm]	Max vert. movement [mm]	Suction cup weight [g]
	-20 kPa	-60 kPa	-90 kPa	-20 kPa	-60 kPa	-90 kPa				
SIL 50	3	8.5	11	3	8.5	11	0.5	8	1.5	0.6



CONTENTS

Contents	4
About Gimatic	12
Vacuum theory	18
Suction cups	34
Multistage cartridges for integration	322
Vacuum pumps	358
Customised solutions	432
Suspensions and System accessories	436







Click for Quick Navigation





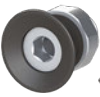

Contents

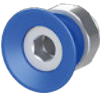

STANDARD SUCTION CUPS



VG.U	SIL 50		VG.U6S	40
			VG.U9S	42
			VG.U11S	44
			VG.U16S	46
			VG.U22S	48
			VG.U33S	50
			VG.U42S	52
			VG.U53S	54

VG.U	EPDM 50		VG.U6E	56
			VG.U9E	58
			VG.U11E	60
			VG.U16E	62
			VG.U22E	64
			VG.U33E	66
			VG.U42E	68
			VG.U53E	70

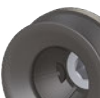

VG.U	HNBR 60		VG.U6H	56
			VG.U9H	58
			VG.U11H	60
			VG.U16H	62
			VG.U22H	64
			VG.U33H	66
			VG.U42H	68
			VG.U53H	70



VG.B	SIL 50		VG.B6S	72
			VG.B9S	74
			VG.B11S	76
			VG.B16S	78
			VG.B22S	80
			VG.B33S	82
			VG.B42S	84
			VG.B53S	86
			VG.B77S	88



VG.B	EPDM 50		VG.B6E	90
			VG.B9E	92
			VG.B11E	94
			VG.B16E	96
			VG.B22E	98
			VG.B33E	100
			VG.B42E	102
			VG.B53E	104



VG.B	HNBR 60		VG.B6H	90
			VG.B9H	92
			VG.B11H	94
			VG.B16H	96
			VG.B22H	98
			VG.B33H	100
			VG.B42H	102
			VG.B53H	104



VG.B	NBR 60		VG.B77N	106
-------------	---------------	---	---------	-----

VG.CF	SIL 50		VG.CF16S	108
			VG.CF22S	110
			VG.CF27S	112
			VG.CF33S	114
			VG.CF42S	116
			VG.CF53S	118
			VG.CF77S	120
			VG.CF112S	122
			VG.CF152S	124

VG.CF	HNBR 60		VG.CF16H	126
			VG.CF22H	128
			VG.CF27H	130
			VG.CF33H	132
			VG.CF42H	134
			VG.CF53H	136
			VG.CF77H	138
			VG.CF112H	140
			VG.CF152H	142

VG.CF	NBR 60		VG.CF16N	126
			VG.CF22N	128
			VG.CF27N	130
			VG.CF33N	132
			VG.CF42N	134
			VG.CF53N	136
			VG.CF77N	138
			VG.CF112N	140
			VG.CF152N	142

VG.LB	HNBR 60		VG.LB6H	144
			VG.LB9H	146
			VG.LB11H	148
			VG.LB16H	150
			VG.LB22H	152
			VG.LB33H	154
			VG.LB42H	156
			VG.LB53H	158

VG.LB	NBR 50		VG.LB6N	144
			VG.LB9N	146
			VG.LB11N	148
			VG.LB16N	150
			VG.LB22N	152
			VG.LB33N	154
			VG.LB42N	156
			VG.LB53N	158

STANDARD SUCTION CUPS

VG.FP	SIL 50		
		VG.FP15S	160
		VG.FP20S	162
		VG.FP30S	164
		VG.FP40S	166

VG.SBC	SIL 40		
		VG.SBC40S	168
		VG.SBC50S	170
		VG.SBC63S	172

VG.BC	SIL 40		
		VG.BC40S	174
		VG.BC50S	176

VG.MB	NBR 60		
		VG.MB52N	178
		VG.MB63N	179
		VG.MB83N	180
		VG.MB103N	181

VG.PAAT	PTFE		
		VG.PAAT.16R	182
		VG.PAAT.20R	182
		VG.PAAT.30R	182
		VG.PAAT.40R	182



POLYURETHANE SUCTION CUPS

VG.IS	PU30/60		
		VG.IS20P	184
		VG.IS25P	186
		VG.IS35P	188
		VG.IS45P	190
		VG.IS55P	192
		VG.IS70P	194

VG.BR	PU50		
		VG.BR20X45	196
		VG.BR30X55	197

VG.LBR	PU50		
		VG.LBR20X45	198
		VG.LBR30X55	199

VG.MF	PU40		
		VG.MF20P	200
		VG.MF30P	202
		VG.MF45P	204
		VG.MF60P	206
		VG.MF80P	207
		VG.MF100P	208
	VG.MF120P	209	

Contents

FOOD-GRADE SUCTION CUPS (FDA-COMPLIANT)

	VG.BPG SIL 50 FDA		
		VG.BPG30F	210
		VG.BPG41F	212
		VG.BPG48F	214
		VG.BPG55F	216

	VG.B.SFO SIL 50 FDA		
		VG.B16F.SFO	270
		VG.B22F.SFO	272
		VG.B33F.SFO	274
		VG.B42F.SFO	276
	VG.B53F.SFO	278	

	VG.BPG SIL 50 FDA		
		VG.BPG30FSI	218
		VG.BPG41FSI	220
		VG.BPG48FSI	222
		VG.BPG55FSI	224

	VG.LB SIL 50 FDA		
		VG.LB6F	280
		VG.LB9F	282
		VG.LB11F	284
		VG.LB16F	286
		VG.LB22F	288
		VG.LB33F	290
		VG.LB42F	292
	VG.LB53F	294	

	VG.LPG SIL 50 FDA		
		VG.LPG30F	226
		VG.LPG41F	228
		VG.LPG48F	230

	VG.LB.SFO SIL 50 FDA		
		VG.LB16F.SFO	296
		VG.LB22F.SFO	298
		VG.LB33F.SFO	300
		VG.LB42F.SFO	302
	VG.LB53F.SFO	304	

	VG.LPG SIL 50 FDA		
		VG.LPG30FSI	232
		VG.LPG41FSI	234
		VG.LPG48FSI	236

	VG.FP SIL 50 FDA		
		VG.FP15F	306
		VG.FP20F	308
		VG.FP30F	310
	VG.FP40F	312	

	VG.U SIL 50 FDA		
		VG.U6F	238
		VG.U9F	240
		VG.U11F	242
		VG.U16F	244
		VG.U22F	246
		VG.U33F	248
		VG.U42F	250
	VG.U53F	252	

	VG.FO SIL 50 FDA		
		VG.FO26F	314
		VG.FO33F	316

	VG.B SIL 50 FDA		
		VG.B6F	254
		VG.B9F	256
		VG.B11F	258
		VG.B16F	260
		VG.B22F	262
		VG.B33F	264
		VG.B42F	266
	VG.B53F	268	

	VG.BDT SIL 40 FDA, Detectable		
		VG.BDT40	318

EJ CARTRIDGES FOR INTEGRATION

EJ-SMALL



EJ-SMALL-LP-2	328
EJ-SMALL-HF-2	330
EJ-SMALL-HV-2	332



Click for Quick Navigation

EJ-MEDIUM



EJ-MEDIUM-LP-2	334
EJ-MEDIUM-LP-3	336
EJ-MEDIUM-HF-2	338
EJ-MEDIUM-HF-3	340
EJ-MEDIUM-HV-2	342
EJ-MEDIUM-HV-3	344

EJ-LARGE



EJ-LARGE-LP-2	346
EJ-LARGE-LP-3	348
EJ-LARGE-HF-2	350
EJ-LARGE-HF-3	352
EJ-LARGE-HV-2	354
EJ-LARGE-HV-3	356

VACUUM PUMPS

EJ-BA



EJ-BA-MEDIUM	368
EJ-BA-MEDIUMX2	372

EJ-LINE



EJ-LINE-SMALL	376
EJ-LINE-MEDIUM	378

EJ-SYS



EJ-SYS-SMALL	380
EJ-SYS-MEDIUM	382
EJ-SYS-LARGE	384

EJ-SLG



EJ-SLG-MEDIUM	388
EJ-SLG-LARGE	392

VACUUM PUMPS

EJ-ATM



EJ-ATM-LINE-SMALLX2-LP-2	398
EJ-ATM-MEDIUM-HV-2	400

EJ-MLG



EJ-MLG-LARGE	418
--------------	-----

EJ-BLOWOFF



EJ-BLOWOFF-MEDIUM-HF-2	402
EJ-BLOWOFF-MEDIUMX2-HF-2	404
EJ-BLOWOFF-LARGE	406

EJ-CEN



EJ-CEN-LARGE	422
--------------	-----

EJ-BSV



EJ-BSV-MEDIUM	410
---------------	-----

EJ-XPRO



EJ-XPRO	426
---------	-----

EJ-BSVLG

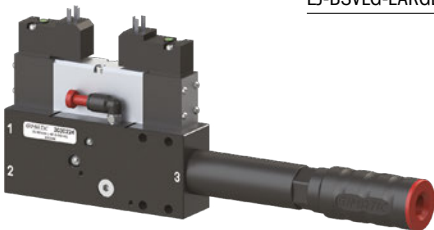

EJ-BSVLG-LARGE	414
----------------	-----

EJ-BBT



EJ-BBT10	430
EJ-BBT20	430
EJ-BBT30	430
EJ-BBT40	430

Contents

SUSPENSIONS

VSRT 440



VSRT1010
VSRT1025
VSRT1420
VSRT1435
VSRT1620
VSRT1635
VSRT2025
VSRT2050

VSET 442



VSET1010F05
VSET1025F05
VSET1620F18
VSET1635F18
VSET2025F18
VSET2025F14
VSET2050F18
VSET2050F14

VSNTG 444



VSNTG1010
VSNTG1025
VSNTG1210
VSNTG1225
VSNTG1420
VSNTG1435
VSNTG1620
VSNTG1635
VSNTG2025F18
VSNTG2025F14
VSNTG2050F18
VSNTG2050F14
VSNTG2540
VSNTG2580

VSNTF 446



VSNTF2050-NC
VSNTF2050-NO
VSNTF30100-NC
VSNTF30100-NO

VSRTF 448



VSRTF2050-NC
VSRTF2050-NO
VSRTF30100-NC
VSRTF30100-NO

BALL JOINTS

VAB 450



VAB18M18F-NC
VAB14M14F-NC
VAB18M18F-NO
VAB14M14F-NO

VACUUM ACTUATORS

VAQ 452



VAQ1820
VAQ1840
VAQN1820
VAQN1840

VACUUM SWITCHES

VACSD 454



VACSM 456



VACSW 458



VACSE 460



VACSP 462



AVG 463



RELEASE SYSTEMS

AQRV 464



BNRV 465



FILTERS

FILTR 466



Gimatic is a leading company that has operated in the industrial automation market for over 35 years. Thanks to its expertise, flexibility and extensive use of new technologies in systems design and implementation, Gimatic is able to offer specific solutions for any application.

Successfully present in the automation sector since its origins, the company boasts today a wide range of products with more than 3500 product codes on catalogue and 180 patents registered.

Gimatic has always had automation in its DNA. In order to achieve an even higher competitive edge in the market, Gimatic started to dedicate itself to pneumatic grippers and combined sensors, first as a technological exploration. Looking firmly towards the future, Gimatic decided in 2001 to actively collaborate with manufacturers and installers of plastic moulding machines and soon became the undisputed leader in EOAT (End Of Arm Tooling) systems.

The expertise in precision mechanics – gained through a successful presence in the handling market – combined with the know-how in sensor electronics made possible the birth of mechatronics in 2012. This is how the first products of the mechatronics range were born (2- and 3-jaw electric parallel grippers and electric actuators), a range that in 2013 already counted over 50 products.

What makes a company competitive is its continuous desire to grow. Gimatic has demonstrated this again by investing in the industrial vacuum sector, which therefore allows to provide its customers with complete gripping solutions, with advanced control systems and high quality components.

Always attentive to technological innovation, Gimatic has made it possible to achieve a high level of integration of its products, services (for example 3D printing and laser cutting) and technologies in an Information Technology perspective. Integration also made possible by the presence of a production plant consisting of more than 70 CNC machining centers in view of Industry 4.0, able to process any type of material: stainless steel, tempered steel, aluminium, titanium, technopolymers and zamak...



Gimatic designs and builds bespoke solutions for its customers' applications.

PARTNERS OF EXCELLENCE

Gimatic's highly qualified staff develops and designs solutions for specific vacuum applications, also thanks to the support of a global network of subsidiaries, some of which play the important role of Competence Center. This makes it possible to centralise new experiences, to enable technology transfer and training on advanced technologies, as well as to have a unified approach and a global quality standard.

Gimatic has always been quality-oriented in its internal processes and in the products and services offered, a natural vocation for quality that has led to the ISO 9001 and ISO 14001 certifications.



+35

YEARS OF EXPERIENCE

+3500

CODES ON CATALOGUE

+180

PATENTS REGISTERED

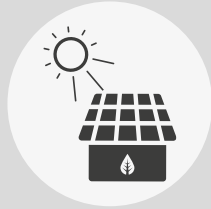

ECO-FRIENDLY PRODUCTION



VERTICAL PRODUCTION



INTERNSHIPS / COLLABORATIONS WITH UNIVERSITIES



EOAT TRACEABILITY



CENTRE OF COMPETENCE



+35 YEARS OF SUCCESS



PRODUCT WARRANTY



BESPOKE APPROACH

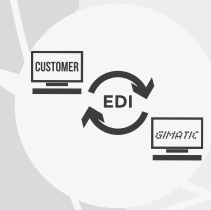

DEDICATED ELECTRONIC INTERFACE

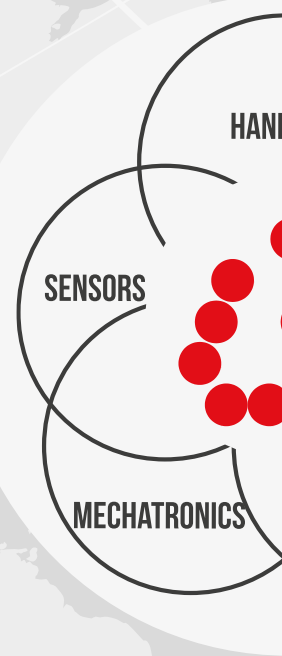

EXPANSIVE INNOVATION

Customers can count on a widespread, organised and reliable network of 30 distributors and 20 subsidiaries, essential to ensure a continuous flow of new products. Thanks to Gimatic's efficient processes, products are shipped within 24 hours from the order with official warranty. Efficiency, in view of Industry 4.0, also in terms of after-sales and preventive maintenance thanks to the traceability of systems through RFID technology, dedicated electronic interfaces, parts documentation and CAD files.

Not only does the sales network sell Gimatic's products, it also serves the important function of collecting users' requests. This, in turn, helps to build specific solutions for the required applications and to continuously improve the products offered.

Gimatic's latest challenge is its internationalisation pushed to the highest levels. The direct and indirect distribution network is an important factor that drives large international groups to collaborate with Gimatic. For this reason the opening of new branches is not only the result of local opportunities but follows a much larger project of support and dissemination of quality standards.

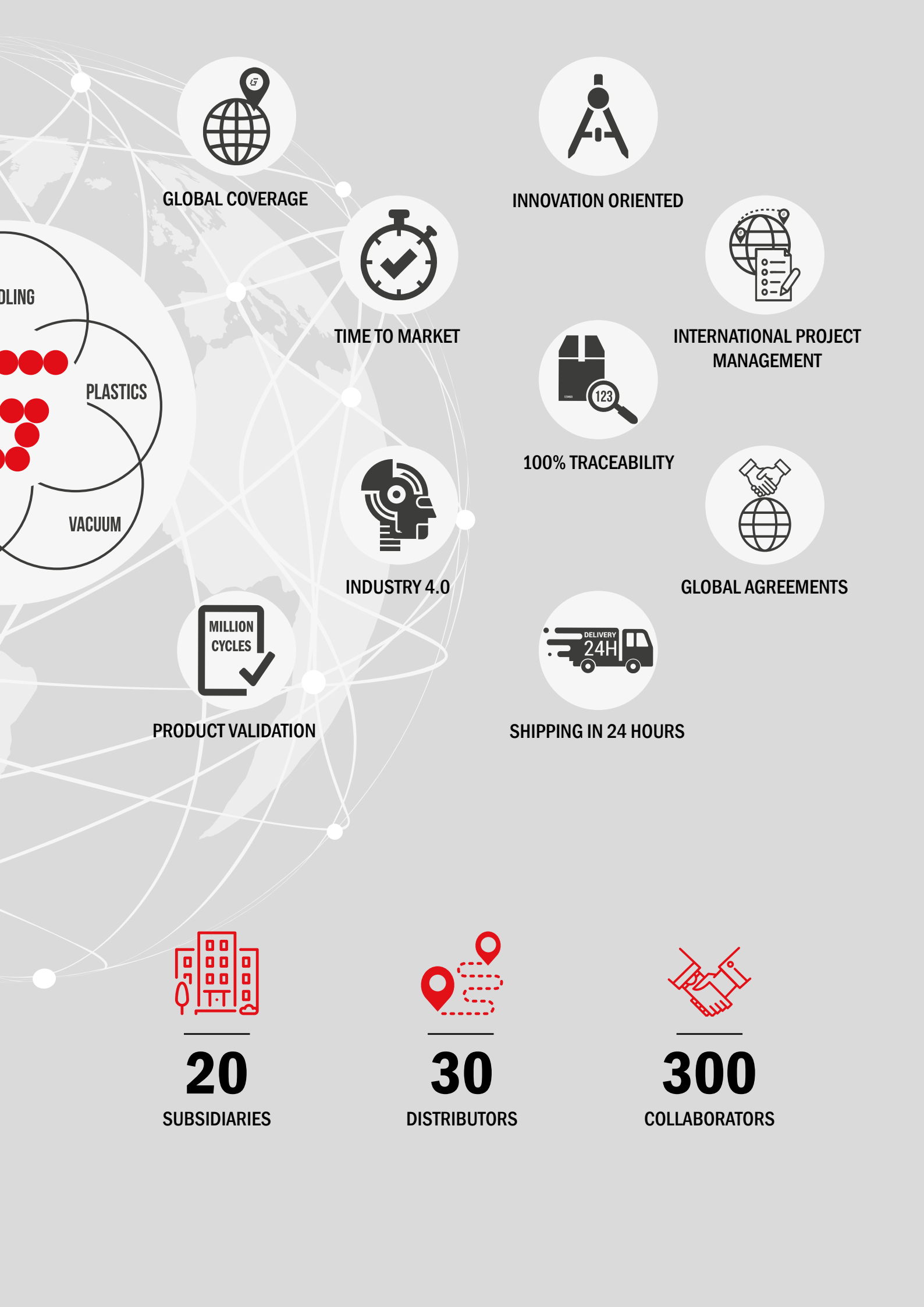

GLOBAL COVERAGE



INNOVATION ORIENTED



INTERNATIONAL PROJECT MANAGEMENT



TIME TO MARKET



100% TRACEABILITY



INDUSTRY 4.0



GLOBAL AGREEMENTS

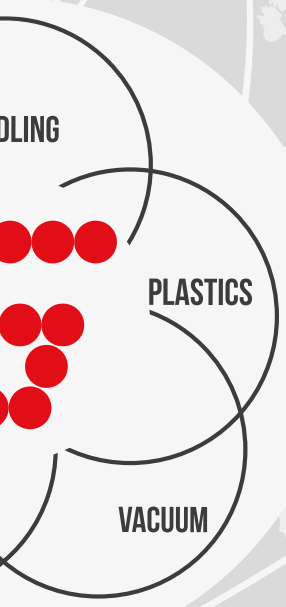

PRODUCT VALIDATION



SHIPPING IN 24 HOURS



20

SUBSIDIARIES



30

DISTRIBUTORS



300

COLLABORATORS

INDUSTRIES

Thanks to its extreme versatility and a wealth of experiences acquired in over thirty-five years, Gimatic is able to fully satisfy all needs in the most innovative industrial sectors.

Gimatic has always been particularly attentive to the training of its staff and of its sales network. For this reason training courses dedicated to the vacuum technologies for industrial automation are organised. Moreover, Gimatic maintains close relationships with research institutes and universities in order attract young talents, offering them job opportunities at the end of their studies.

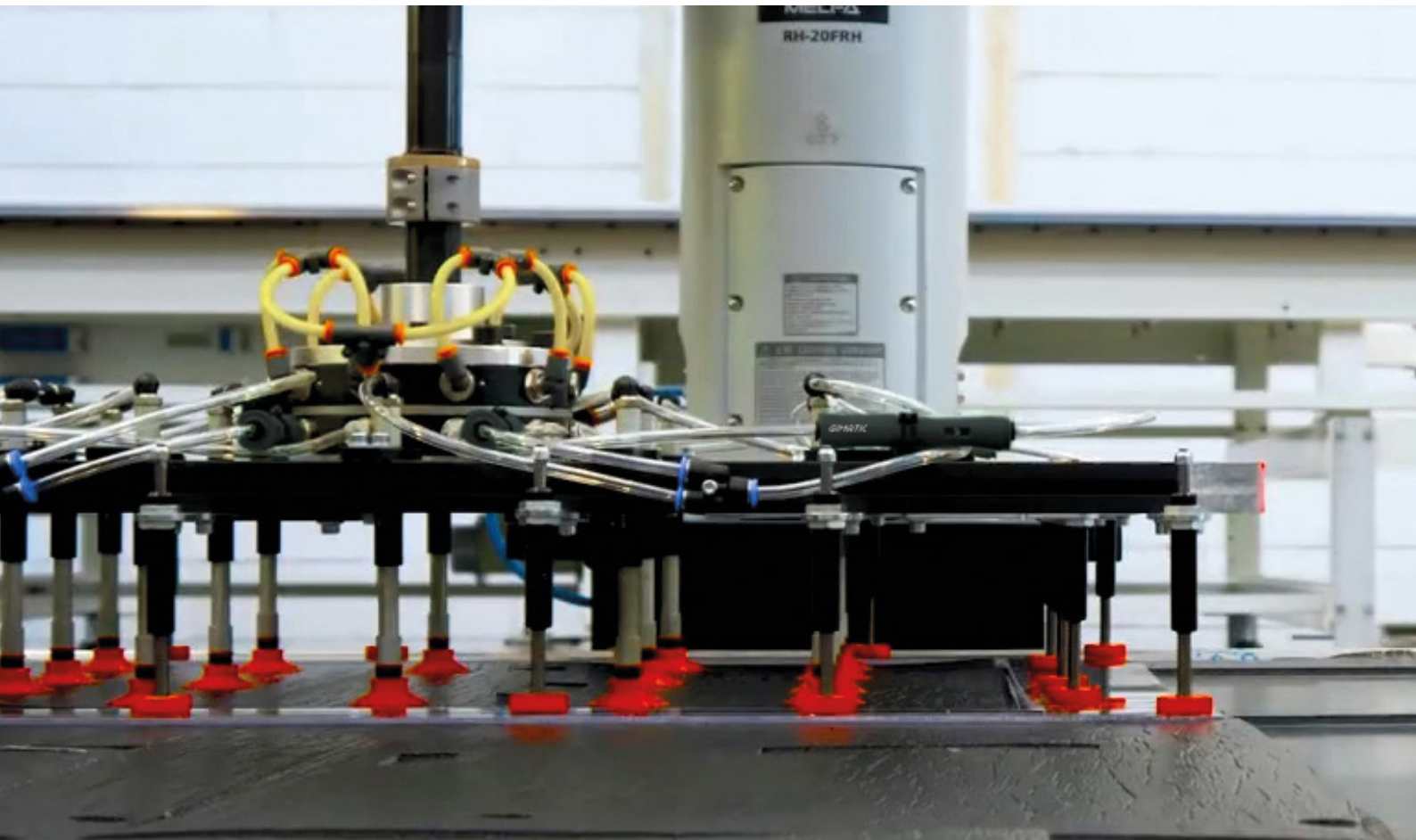

Gimatic maintains close relationships with research institutes and universities



AUTOMOTIVE



ASSEMBLY



PACKAGING



FOOD & BEVERAGE



SHEET METAL



**PHARMACEUTICAL AND
MEDICAL**



ELECTRONIC



WOOD



GLASS



HOUSEHOLD APPLIANCES



COBOTS



LOGISTICS



DEFINITION OF ATMOSPHERIC PRESSURE

Before defining what Vacuum is and what is the correct terminology to be used in this field it is important to know the meaning of atmospheric pressure.

The earth is surrounded by layers of gas mixtures (atmosphere).

The atmosphere surrounding the earth has its own weight.

Atmospheric pressure is defined as the force per unit area exerted against a surface by the weight of the air above that surface. And that is exactly the force magnitude we work with when we use the vacuum. It is a limited magnitude: atmospheric pressure cannot be increased.

It is measured in the International System in Pascal and with a measuring instrument called barometer.

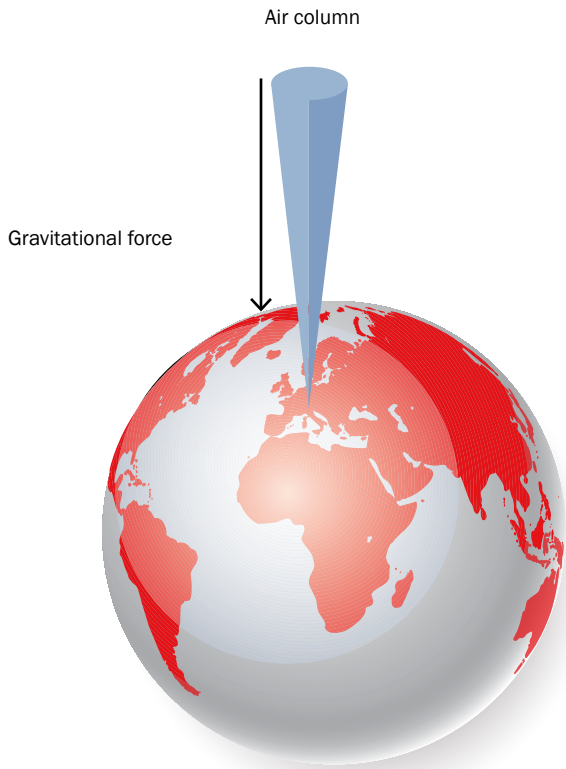

The atmospheric pressure is higher at sea level than at a point on top of a mountain, because the air mass above the point on the mountain is lower than the air mass above the point at sea level.

Airplane
10,000 m 26 kPa

Mount Everest
8,848 m 33 kPa

Mountain
600 m 93.8 kPa

Sea level
0 m 101.3 kPa

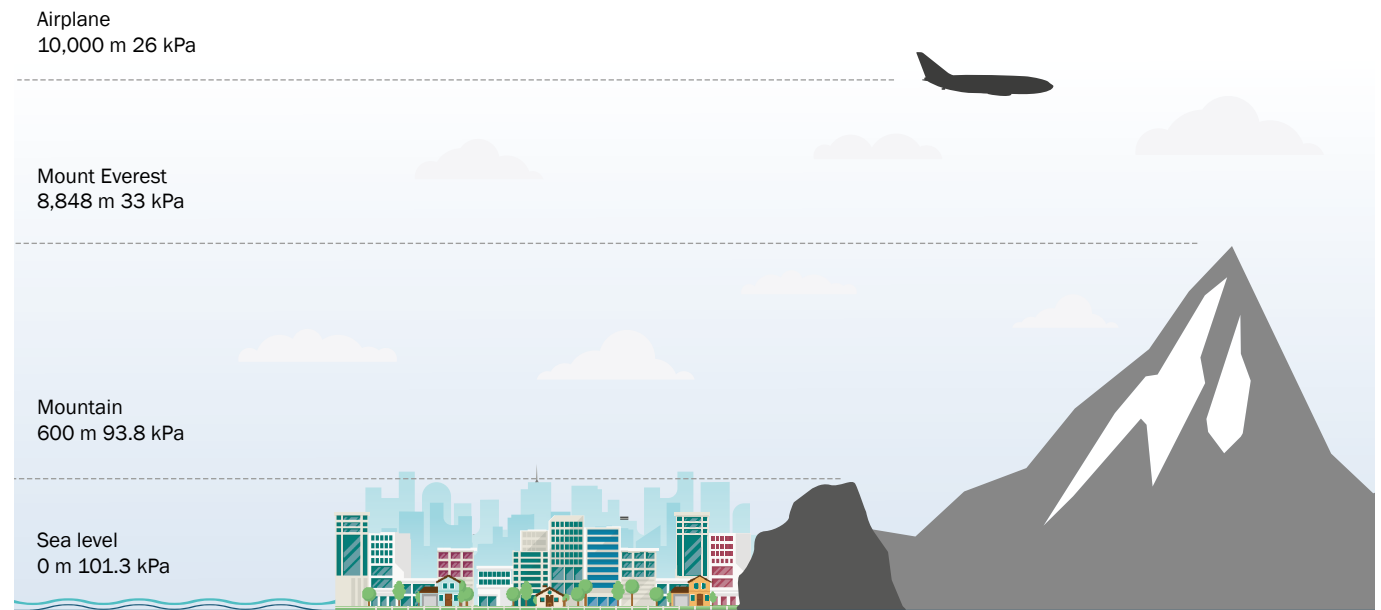

DEFINITION OF VACUUM

In the industrial vacuum sector, different terms and units of measurement are used with regard to pressure and air flow rate. To this end, the meaning of these quantities should be clarified.

VACUUM AS RELATIVE VALUE

In the field of vacuum technology, vacuum is indicated as a relative value, which means that the depression is indicated in relation to the ambient pressure. The vacuum value indicated is preceded by a negative sign because the ambient pressure is indicated with 0 mbar as a reference point.

VACUUM AS ABSOLUTE VALUE

In the scientific field vacuum is indicated as an absolute value. In this case, the absolute zero is used as a reference point, i.e. space without air (e.g. cosmic space). In such a way the vacuum value always has a positive sign. The "absolute vacuum" is intended as the absence of matter in a volume, but this cannot be achieved as it is not possible to completely eliminate all gases. Since a zero pressure value is practically unreachable, the vacuum level value will be a decimal number with the more zeros after the decimal point the lower the pressure value is, i.e. the higher the vacuum level value is.

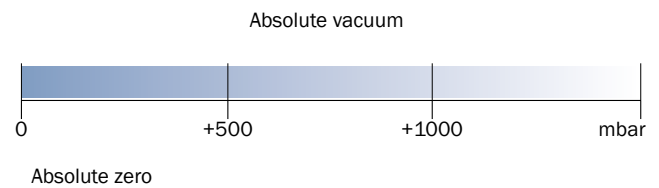
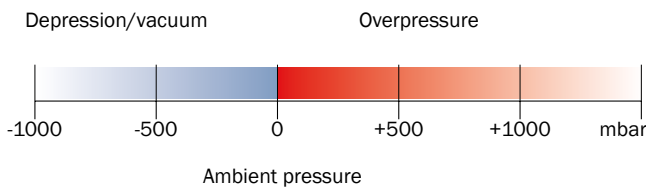

The diagram shows the relationship between absolute, relative and negative pressure. This shows that if the type of pressure one refers to is not specified, serious mistakes can ensue. The 40 kPa value can indicate three different situations.

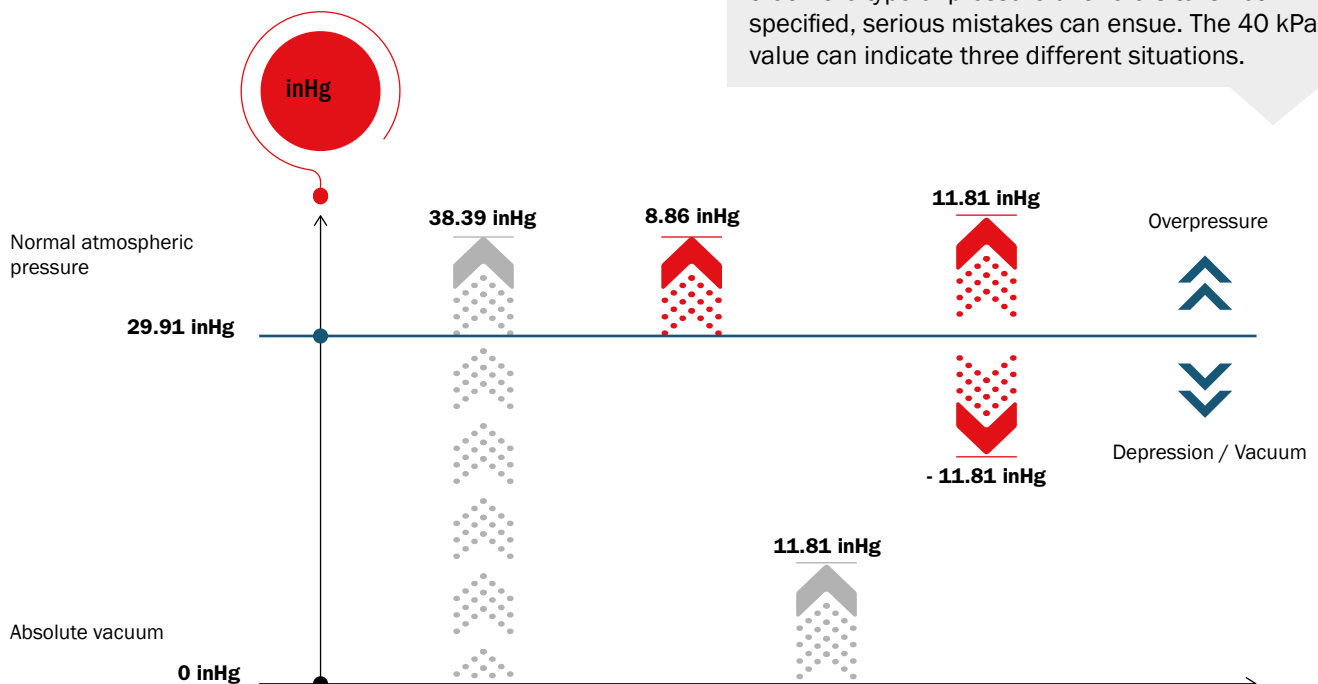

DEFINITION OF PRESSURE

Pressure is defined as the amount of force per unit area applied perpendicularly to the surface of an object.

Gases are made up of a large number of particles, which are constantly moving. When these particles collide on a surface, such collisions generate a thrust, measurable as force. The pressure is the sum of all the forces produced by the particles, per unit area. The particles that make up the gases, when in thermodynamic equilibrium, are uniformly distributed in space, so the gas pressure and composition are uniform at every point of the reference area. It should therefore be noted that there is only one type of pressure, whose starting value is 0 (absolute vacuum). All values above 0 are indicated as absolute pressure. As mentioned above, the value of atmospheric pressure at sea level is 101.3 kPa and is used as a reference point when talking about relative pressure, which can be either negative (depression) or positive (overpressure).

UNIT FOR MEASUREMENT OF PRESSURE

The unit of measurement of pressure in the US Customary System is the pound per square inch (psi):

1 psi is the pressure resulting from a force of one pound-force applied to an area of one square inch. Psi multiples are kilopound per square inch (ksi) and megapound per square inch (Mpsi).

Let us consider a surface S , arranged horizontally, and a force F acting perpendicular to it. Pressure is defined as the ratio between the force F and the surface on which it acts:

$$p = F / S$$

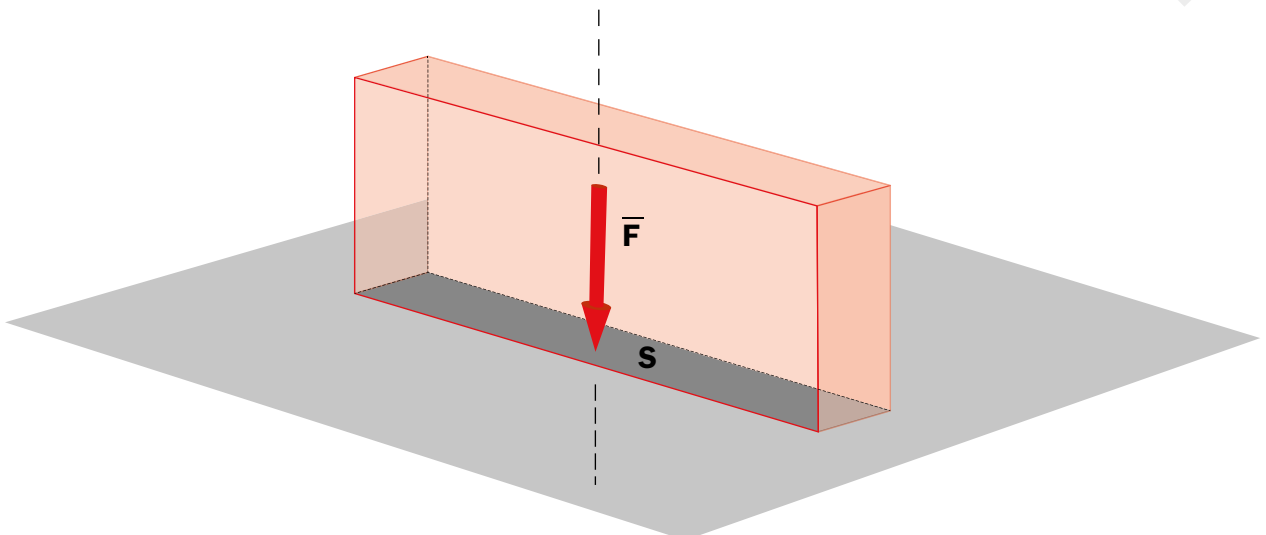

UNITS FOR MEASUREMENT OF VACUUM

In the industrial vacuum sector, different terms and units of measurement are used with regard to pressure and air flow rate.

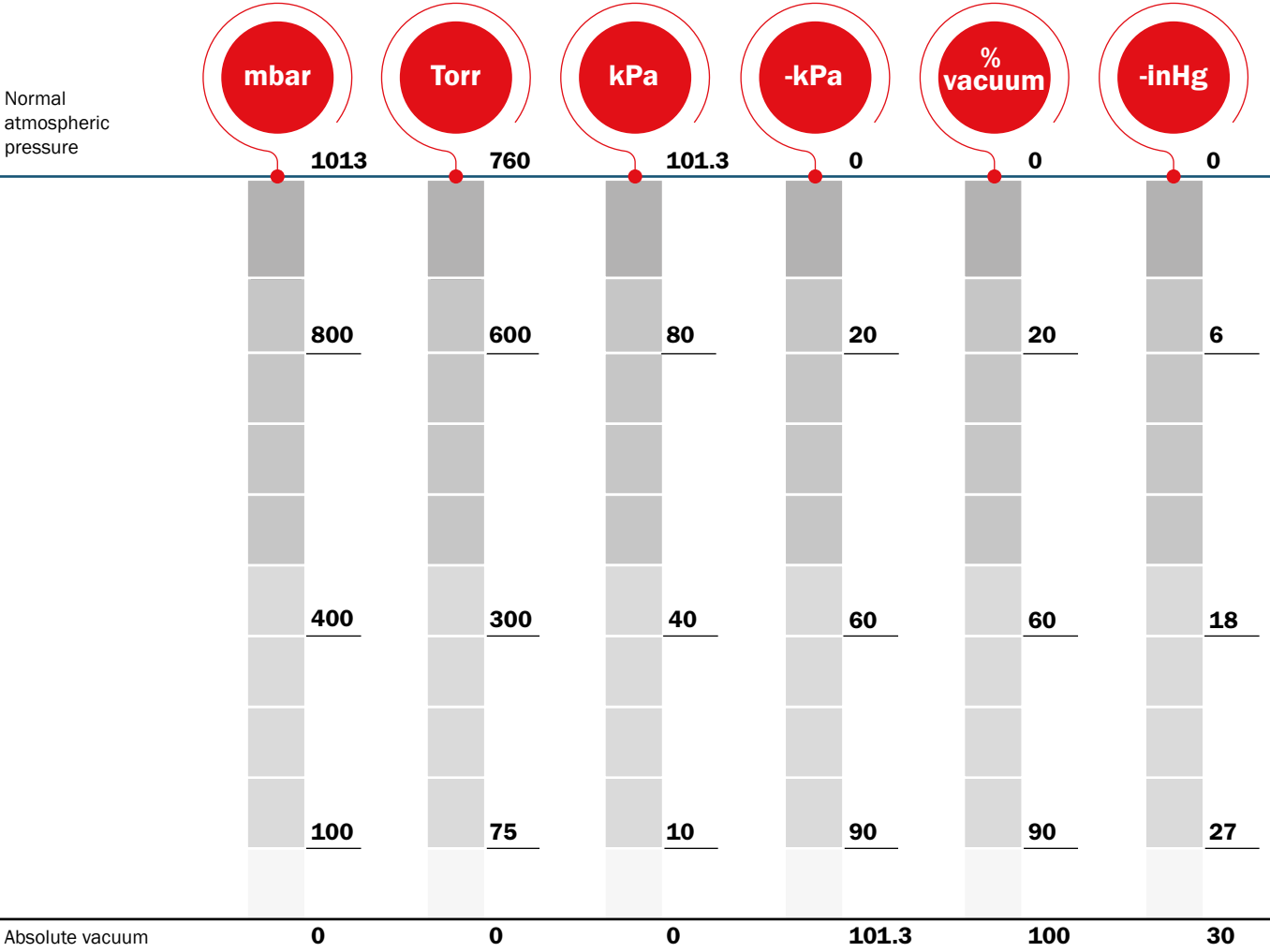

CORRECT TERMINOLOGY TO BE ADOPTED IN INDUSTRIAL VACUUM

The terminology used in the vacuum sector must be consistent in the case of either electromechanical or compressed air systems. Only by speaking the same language can real comparisons be made. The most important terms to understand and use when performing a vacuum circuit are the following:

FLOW RATE

The rate at which atmospheric pressure is evacuated within a system, or the amount of air flowing through a pump. $Q = V/t$

The flow rate also determines the ability to compensate for any leaks. The evacuation speed is inversely proportional to the vacuum level.

FREE AIR FLOW RATE

Determines the amount of air evacuated at a pressure equal to atmospheric pressure. The term is often used by manufacturers of vacuum pumps to indicate their characteristics.

VACUUM LEVEL

The term defines the pressure level within a circuit, which is usually measured in kPa.

The vacuum level determines the lifting force of a suction cup, or the amount of residual atmosphere.

As the vacuum level increases, the evacuation rate decreases.

COMPRESSED AIR

It is the energy source that powers a pneumatic vacuum pump. Compressed air is comparable to the electricity that powers an electromechanical vacuum pump.

It is supplied by a compressor and is distributed by means of suitably dimensioned pipes.

COMPRESSED AIR PRESSURE

The compressed air pressure is measured in bar.

The optimum performance of a compressed air pump is achieved by balancing the pressure delivered by the compressor with the required vacuum level.

EVACUATION TIME

The time required to evacuate a given volume of air at a specific vacuum level measured in s/l.

$$\text{Evacuation time} = \frac{\text{Required gripping time}}{\text{System volume}}$$

CONSUMPTION

In industrial vacuum, the consumption of an air pump is measured in standard cubic feet per minute (scfm) or standard cubic feet per second (scfs)

STANDARD CUBIC FOOT (SCF)

The standard cubic foot is the volume that a certain amount (mass) of gas would occupy if it were returned to atmospheric pressure.

We can therefore say that the standard cubic foot is the unit used to measure the mass of a gas.

The gases are compressible, therefore their quantity cannot be indicated by simply indicating the volume they occupy, but the pressure at which they are must also be indicated.

The standard cubic foot is useful to compare gas volumes at different pressures.

In the case of mechanical vacuum pumps it is used to clearly indicate the suction air flow rate.

In the case of pneumatic vacuum pumps, it also serves to correctly indicate the consumption of compressed air that generates the vacuum.

LIFTING FORCE

The lifting capacity of a suction cup is determined by the ratio between the pressure and the contact surface area.

VOLUME

The total area of a circuit including all spaces as well as the application area.

VACUUM CLASSIFICATION

The vacuum is usually divided into three application areas, which depend on the vacuum level required.

LOW VACUUM LEVEL

Used in all those applications where a high air flow rate is required. The vacuum level is usually between 0 and -5.91 inHg.

Electromechanical impeller pumps are usually used in this segment. Screen printing on fabrics is one of the typical applications that require a low vacuum level and a high suction flow rate. (Application for ventilation, cooling or cleaning).

INDUSTRIAL VACUUM

The term industrial vacuum means a vacuum between -5.91 and -29.94 inHg. This range covers most applications. Industrial vacuum is used in applications that require material handling, lifting and sealing.

PROCESS VACUUM

These are applications where the vacuum level reached can exceed -29.24 inHg. The unit of measurement used is normally the Torr. The suction flow rate is minimal and scientific applications include space simulations. (Coating with molecular deposit)

The highest vacuum level reached on earth deviates significantly from the absolute vacuum value, which remains a purely theoretical value. Even in space and therefore in the absence of atmosphere there is a minimal presence of atoms.

VACUUM PRODUCTS

HOW TO CREATE A VACUUM

Although there are several ways to create vacuum, two are the main methods used to generate it, and they employ:

PNEUMATIC EJECTOR PUMPS

COMPRESSED AIR PUMPS

Vacuum pumps, usually defined as vacuum generators, use the Bernoulli's principle which states that a relationship exists between pressure and speed: as the speed of a moving fluid (air or water) increases, the pressure within the fluid decreases and vice versa.

EJECTOR

The principle of operation of air vacuum generators consists of injecting compressed air into a conical nozzle called ejector. The compressed air through the conical nozzle reaches a supersonic speed that attracts low pressure molecules.

The external atmospheric pressure will flow, trying to restore balance to the system. The mix of compressed air passing through the ejector and the air at external atmospheric pressure flows through the exhaust.

The vacuum level that an ejector can reach depends on the ejector configuration.

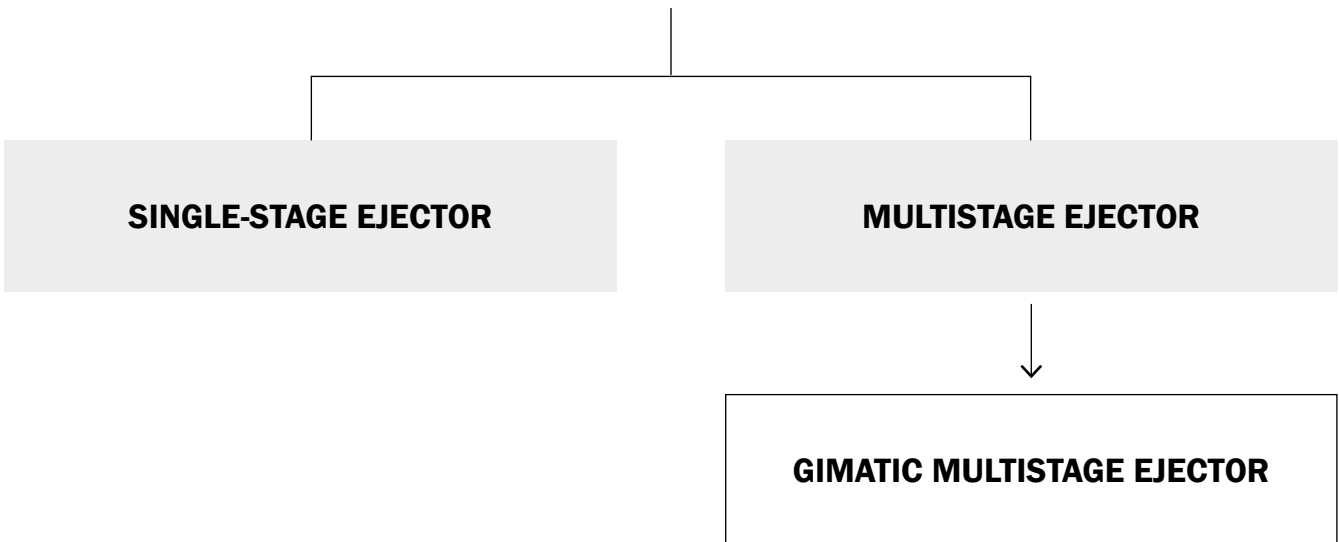

Gimatic develops and produces (in Italy) multistage ejectors, identified with the acronym EJ. Our cartridge ejectors are available in three sizes (EJ-SMALL, EJ-MEDIUM, EJ-LARGE). These ejectors ensure excellent performance at both high and low feed pressures.

MECHANICAL PUMPS

The fundamental characteristic, common to all mechanical pumps, is that they convey a certain volume of air from the suction area to the discharge area, thus creating a depression. Mechanical pumps are generally driven by an electric motor, sometimes by an internal combustion engine, hydraulic or pneumatic.

VOLUMETRIC PUMPS

Volumetric pumps mechanically move the trapped fluid volumes through the system. On the inlet side the volume expands, while on the outlet side (exhaust) the volume contracts. Therefore the volume per revolution is fixed, and in theory is constant, regardless of outlet pressure, inlet depression or fluid properties. The volumetric pumps are self-priming, i.e. they create strong depressions at the inlet. The behaviour of volumetric pumps is different from that of centrifugal pumps, as the latter rely on the pulse of the accelerated fluid to provide flow rate to the pressure and are very sensitive to pressure changes. Volumetric pumps include vane pumps and lobe pumps.

BLOWER PUMPS

The centrifugal blower pump is composed of a suction pipe that conveys the gas sucked at the inlet. The pump contains a closed impeller with axial inlet and radial outlet. A radial diffuser, located inside, converts the impeller's output kinetic energy into pressure energy. These pumps work at very low vacuum levels, are able to move large masses of air and have a high suction flow rate.

VANE

LOBE

VACUUM PRODUCTS

PRINCIPLES OF OPERATION

GIMATIC MULTISTAGE EJECTOR

The Gimatic "EJ" ejectors are composed of several De Laval nozzles arranged in series that use the exhaust air from the previous nozzle for their feeding, thus reducing noise and increasing pump efficiency.

The diameter of the nozzle is proportional to the air suction capacity and is inversely proportional to the vacuum level generated.

The better performance resulting from a higher number of stages with relevant ejector, allows to optimise the performance of the pump. Every stage can reach a different level of vacuum. When, due to the combined action of the various ejectors, the pressure present in the common stage reaches a value higher than the reference ejector, this causes the closure of the individual rubber membranes (flaps) in sequence, leaving only the high vacuum stage open. The external atmosphere flows through the common stage in an attempt to rebalance the pressure in the system. Compressed air and external atmosphere are mixed and flow through the exhaust.

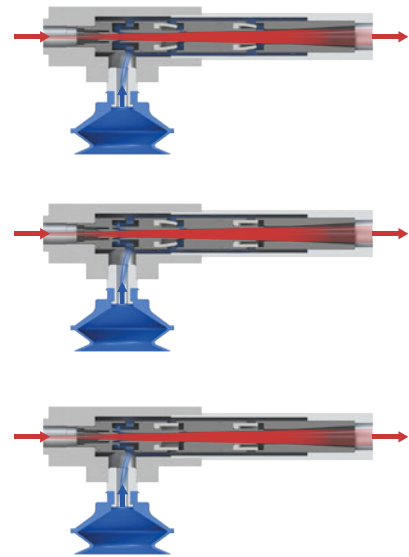

SINGLE-STAGE EJECTOR



GIMATIC EJ MULTISTAGE EJECTOR

COMPRESSED AIR CONSUMPTION

The ratio of air consumed to suction flow rate is rarely higher than 1:1. Historically, this has led to considering the system to be inefficient.

NOISE LEVEL

90 decibel.

COMPRESSED AIR CONSUMPTION

It exploits the kinetic energy of compressed air that passes through De Laval nozzles. The passage of compressed air through a series of suitably sized ejectors allows a gradual expansion of the air.

In this case the ratio of consumption to suction air flow rate is on average three times more efficient, with an efficiency equal to 3:1.

NOISE LEVEL

In the case of the Gimatic multi-stage ejector, the noise level is reduced to values between 55 and 75 decibels.

MECHANICAL PUMPS

VOLUMETRIC VANE PUMPS

Vane pumps have only one rotating element pointing in an eccentric direction with respect to the pump cavity. The rotating element contains several vanes that can slide or deform to fit the profile of the cavity wall. The vanes form a sliding seal positioned against the cavity wall, holding the volume of the fluid at the inlet and allowing it to flow out towards the outlet. Vane pumps are particularly insensitive to pressure changes, as the vanes are in contact with the cavity wall. However, the sliding movement between the vanes and the wall creates noise, risk of pollution of the conveyed fluid and a frequent need for maintenance. (Figure 1)

BLOWER PUMPS

In this type of pumps, the gas is sucked into the chamber from the loading opening. When the gas enters through the side channel the movement of the impeller transmits a certain speed to the gas in the direction of rotation. The centrifugal force of the impeller vanes accelerates the gas outwards and the pressure increases. Each rotation increases the kinetic energy, with a further increase of the pressure in the side channel. The channel narrows towards the rotor, dragging the gas away from the impeller vanes to discharge it through the exhaust silencer. (Figure 3)

VOLUMETRIC LOBE PUMPS

These pumps have lobe-shaped elements instead of gears. Each lobe-shaped element is driven by a motor. This eliminates contact between the two lobes, reducing wear and minimising fluid friction. Usually this type of pumps are characterised by high heat emissions and high noise levels. (Figure 2)

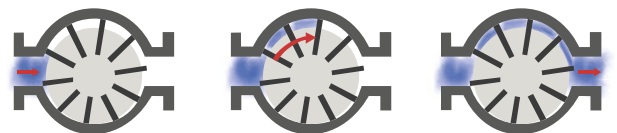

1. Volumetric vane pump operation

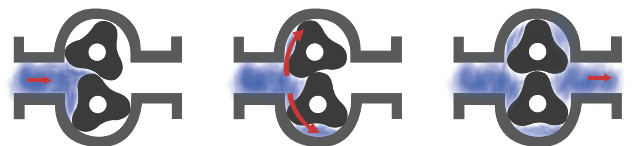

2. Volumetric lobe pump operation

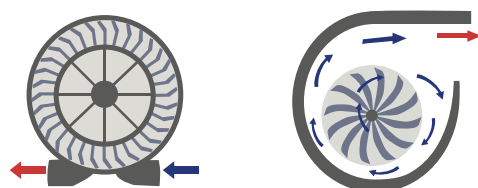

3. Blower pump operation

SIZING OF VACUUM SYSTEMS

In order to achieve greater efficiency and good energy savings, it is important that the systems are expressly designed for the specific application. Likewise, suction cups and their fittings, the model, the size of the vacuum pumps, and relevant accessories and piping, must also be chosen according to the application.

It is extremely important to fix the safety factor during the dimensioning of a vacuum system as well as the type of circuit to be adopted.

FACTOR OF SAFETY

When handling any type of object, the most important condition to be met is the safety of the grip. It is necessary to be sure that the object does not detach from the suction cups before the set release point. For this reason it is always necessary to multiply the weight (plus any inertia force) of the object to be moved by an appropriate safety coefficient:

- 2 in the case of static applications or low-speed handling applications.
- 2.5 or more in the case of medium- and high-speed handling applications.

A parameter that is frequently underestimated when sizing a vacuum system is the choice of the suction cup. It is the device that physically "connects" the object to be manipulated to the gripping system.

TYPE OF CIRCUIT

SEALED SYSTEMS

When designing this circuit it is necessary to consider the volume, the vacuum level and the evacuation time. In sealed systems, the pump capacity is determined by the speed at which the circuit is evacuated at a certain vacuum level.

This capacity is called evacuation time and is normally specified in s/l.

By multiplying this value by the volume of the entire system, the evacuation time is obtained as a function of the desired vacuum level.

SYSTEMS WITH LEAKS

In systems with leaks, where it is necessary to handle cardboard boxes, perforated sheet metal or objects with micro-holes, the situation is different. To maintain the desired vacuum level, the pump must have a higher capacity to compensate for leaks. Once the leakage flow has been determined, the most suitable pump is chosen by checking the characteristic curves of the various pump models. In the case of leaks through a hole with a known cross-section, the extent of the leak can be determined. To obtain the total leak flow, multiply the value obtained by the total area. When porous materials have to be handled or when the geometry of the leak path is unknown, the flow rate can be determined by a practical test to be performed with a pump and a vacuum gauge.

GENERAL INFORMATION FOR CORRECT VACUUM SIZING

A vacuum circuit can be sized following a centralised or decentralised design.

CENTRALISED SYSTEM

DECENTRALISED SYSTEM

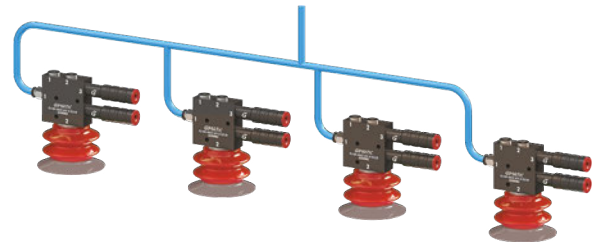

A centralised system is characterised by a vacuum pump connected to several suction cups. Often used to handle sealed materials such as sheet metal or glass.

A decentralised system is designed so that each suction cup has a dedicated vacuum generator, which means that all suction cups are independent of each other, usually used in applications with porous surfaces.

ADVANTAGES



- Single source of vacuum
- Simple blow-off arrangement
- Easy vacuum level control

ADVANTAGES

- Minimised volumes to be evacuated >High gripping and release speed
- Zeroing of pressure drops > Compact pump sizes
- Each suction cup is independent
- Smaller feed pipes

DISADVANTAGES



- Long pipes with larger diameter
- Risk of pressure drops
- Requires blow-off valve or vacuum breaker for release of the object

DISADVANTAGES

- More complex management of blow-off (non-return valves are required)
- More complex detection of object being picked up
- Possible problems resulting from dirt in the system

CHOICE OF THE PUMP

After selecting the components that precede it, the pump must be sized considering some of the following parameters:

IS THE CIRCUIT CENTRALISED OR DECENTRALISED?

WHAT IS THE SPEED OF THE APPLICATION?

POROSITY OF THE MATERIAL?

WHAT IS THE VOLUME TO BE EVACUATED?

WHAT IS THE REQUIRED VACUUM LEVEL?

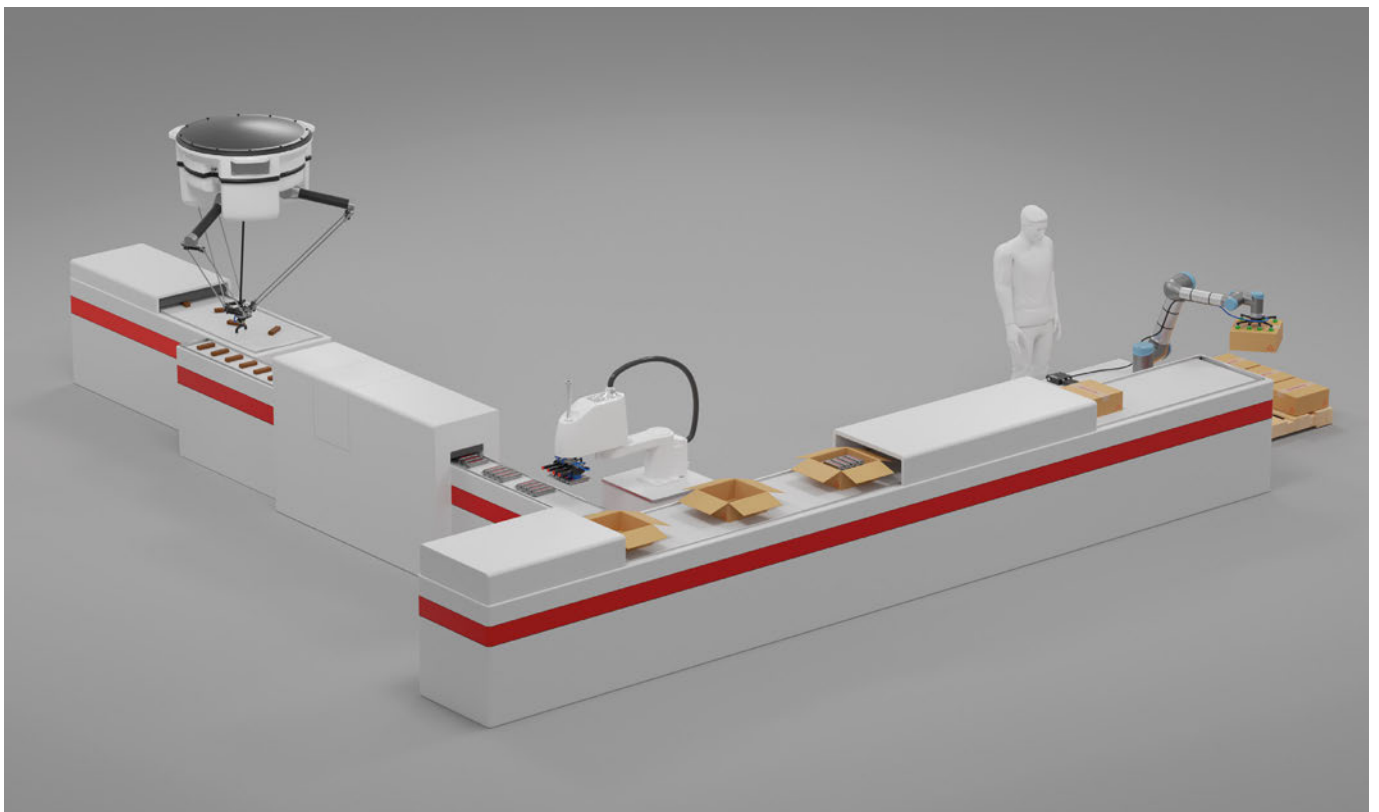

SUCTION CUPS

OPERATING PRINCIPLE OF THE SUCTION CUP



When a vacuum-based handling system is implemented, it is necessary to develop a magnitude of forces that will enable the safe handling of products. The suction cup plays a key role in this phase.

Two are the main factors to be considered:

- The shape of the suction cup;
- The characteristics of the lip.

A suction cup with the proper shape is necessary to match perfectly the morphology of the gripped object. The lip, on the other hand, must be able to follow with precision and repeatability the roughness and alterations that the surface of the object may present (the corrugations of a cardboard box or the roughness of a wooden panel).

The suction cup adheres to the surface when the pressure of the surrounding area (atmospheric pressure) is greater than the pressure between the suction cup and the surface. In order to create a depression inside the suction cup, the suction cup is connected to a vacuum pump. The higher is the vacuum level inside the suction cup, the higher is the force that the suction cup can exert.

Finally keep in mind the force of the suction cup will be higher:

- If the contact surface is large
- If the vacuum level is high
- If its shape can properly match with the object

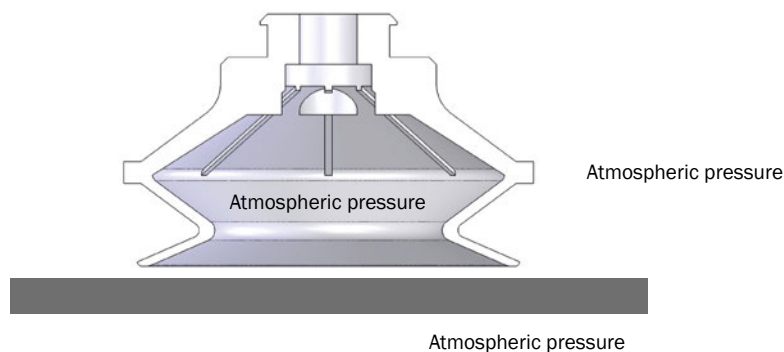

SIZING OF THE SUCTION CUPS



Besides being influenced by the vacuum level, the lifting force is also strongly influenced by the model of suction cup. To design the circuit it is necessary to start from the point of contact between the suction cup and the object and then go back to the vacuum pump. This method allows the proper sizing of the components and the best performance.

Before selecting a suction cup, the surface, structure, lifting direction, weight and porosity of the object must be considered.

THE HIGHER THE VACUUM LEVEL, THE GREATER THE ENERGY REQUIREMENT WILL BE



When vacuum is created inside a suction cup that rests on a surface, the suction cup adheres to the surface not just on its own account, but also thanks to the higher external pressure. The lifting force is proportional to the contact surface and the vacuum level. If the vacuum level increases from 60% to 90%, the lifting force increases by a maximum of 1.5 times. In order to limit the energy consumption, it is preferable to limit the vacuum level and instead increase the surface area of the suction cup.

SURFACE AND STRUCTURE



As well as highlighting the object's dimensions, a visual assessment identifies whether the object is curved or flat. Using the suction cup that best fits the surface is essential. A further contribution could come from the analysis of the structure of the object.

A more careful examination could reveal a certain roughness which, in addition to limiting the use of suction cups, represents a potential leak.

POROSITY

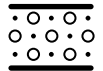

What is the porosity of the material? This question is very important for the definition of the suction cup format and for the sizing of the pump. Porosity is defined as the amount of air at atmospheric pressure passing through a material subjected to a depression. Glass does not allow air to pass through, while paper, for example, is full of tiny pores.

MATERIAL



It is often necessary to check the operating temperature required to perform that particular application. Too high temperatures, as in thermoforming, or too low, require the use of suction cups made with special compounds. Silicone is the best solution even if there is a risk of releasing small particles (halo), which makes it difficult to perform a subsequent painting. In this case our HNBR suction cups are the ideal solution.

SELECTION OF THE SUCTION CUP



Once the weight and size of the object have been determined, the type and diameter of the suction cup must be determined. The use of the largest possible suction cup allows to reduce the vacuum level. This solution offers a number of advantages including shorter evacuation time, reduced power consumption and longer suction cup life.

PARAMETERS

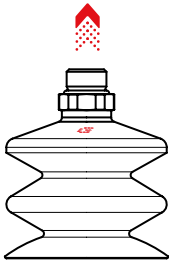
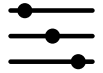

Lifting force [N]
perpendicular to the
surface, at various
vacuum levels

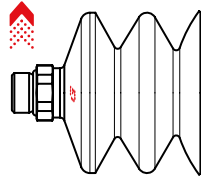

Lifting force [N]
parallel to the
surface, at various
vacuum levels

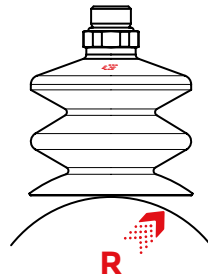

Min curve radius

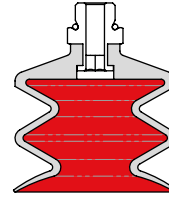

Volume

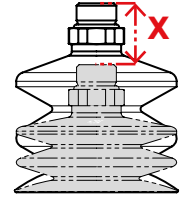

Max vertical
movement

USEFUL PARAMETERS TO VERIFY



- Use the suction cup that is suitable for the application
- Pay attention to the type of material and the structure of the surface
- Determine the type of suction cup material suitable for the application
- Design the system with a suitable safety factor
- Know the possible dynamic forces that could influence the application
- Distribute the suction cups in relation to the centre of gravity
- Use the appropriate accessories for the application
- Consider the type of finish of the surface

STANDARD & POLYURETHANE SUCTION CUPS

VG.U	Flat Silicone	
VG.U	Flat EPDM & HNBR	
VG.B	Bellow Silicone	
VG.B	Bellow EPDM & HNBR	
VG.B	Bellow NBR	
VG.CF	Flat-Ribbed Silicone	
VG.CF	Flat-Ribbed HNBR & NBR	
VG.LB	Multi-Bellow HNBR & NBR	
VG.FP	Multi-Bellow Silicone	
VG.SBC	Multi-Bellow Silicone	
VG.BC	Multi-Bellow Silicone	
VG.MB	Non-Slip Bellow NBR	
VG.PAAT	For Carbon Fiber PTFE	
VG.IS	Dual-Durometer PU	
VG.BR	Rectangle BellowPU	
VG.LBR	Rectangle Multi-Bellow PU	
VG.MF	Non-Slip Flat PU	

FOOD-GRADE SUCTION CUPS (FDA-COMPLIANT)

VG.BPG	Flat Silicone FDA	
VG.BPG	Flat Silicone FDA	
VG.LPG	Multi-Bellow Silicone FDA	
VG.LPG	Multi-Bellow Silicone FDA	
VG.U	Flat Silicone FDA	
VG.B	Bellow Silicone FDA	
VG.B.SFO	Foam Bellow Silicone FDA	
VG.LB	Multi-Bellow Silicone FDA	
VG.LB.SFO	Foam Multi-Bellow Silicone FDA	
VG.FP	Multi-Bellow Silicone FDA	
VG.FO	Non-Slip Silicone FDA	

FOOD-GRADE SUCTION CUPS (FDA-COMPLIANT, DETECTABLE)

VG.BDT	Multi-Bellow Silicone FDA	
---------------	---------------------------	---





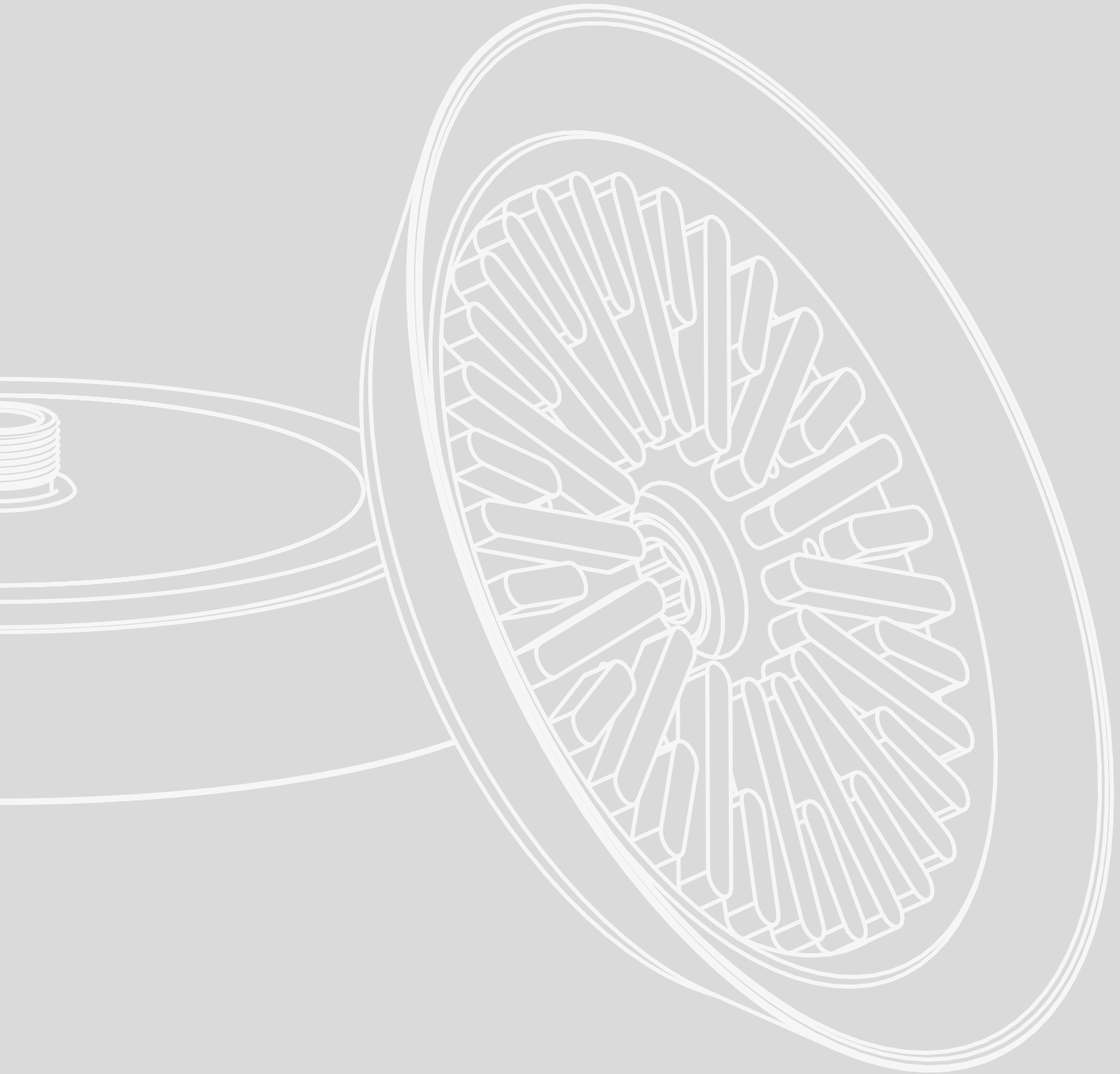











Click for Quick Navigation



SUCTION CUPS

SUCTION CUP SELECTION BY TYPE OF APPLICATION

Type of suction cup	EPDM	NBR	HNBR	SILICONE	FDA-COMPLIANT SILICONE	DETECTABLE FDA-COMPLIANT SILICONE	POLYURETHANE	PTFE
VG.U 	SHEET METAL, GLASS, PLASTIC	–	GLASS, PLASTIC, MARK-FREE	PLASTIC	FOOD-GRADE (FDA)	–	–	–
VG.B/SFO 	SHEET METAL, GLASS, WOOD, PLASTIC, CARDBOARD	–	GLASS, PLASTIC, MARK-FREE	CARDBOARD	FOOD-GRADE (FDA) UNEVEN AND POROUS SURFACES	–	–	–
VG.CF 	–	SHEET METAL, WOOD, MARBLE	GLASS, PLASTIC, MARK-FREE	CARDBOARD	–	–	–	–
VG.LB/SFO 	–	WOOD	SHEET METAL - PLASTIC - MARK-FREE	–	FOOD-GRADE (FDA)	–	–	–
VG.FP 	–	–	–	BAG OPENING, THIN FILMS/PAPER	FOOD-GRADE (FDA) BAG OPENING, THIN FILMS/PAPER	–	–	–
VG.BC/SBC 	–	–	–	BAGS, FLOW PACKS	–	–	–	–
VG.MB 	–	SHEET METAL, GLASS, OILY SHEET METAL	–	–	–	–	–	–
VG.PAAT 	–	–	–	–	–	–	–	PLASTIC, COMPOSITES, FIBERS
VG.IS 	–	–	–	–	–	–	UNEVEN AND POROUS SURFACES	–

Type of suction cup	EPDM	NBR	HNBR	SILICONE	FDA-COMPLIANT SILICONE	DETECTABLE FDA-COMPLIANT SILICONE	POLYURETHANE	PTFE
VG.BR/LBR 	-	-	-	-	-	-	THIN FILM/PAPER - BAGS, FLOW PACKS, OBLONG SNACKS	-
VG.MF 	-	-	-	-	-	-	OILY SHEET METAL	-
VG.BPG/LPG 	-	-	-	-	FOOD-GRADE (FDA) BAGS, FLOW PACKS	-	-	-
VG.FO 	-	-	-	-	FOOD-GRADE (FDA) BAG OPENING, FLOW PACKS, THIN FILMS/PAPER	-	-	-
VG.BDT 	-	-	-	-	-	BAKERY PRODUCTS WITH SEEDS. SILICONE COMPLIANT WITH FDA 21 CFR 177.2600 AND REGULATION (EC) NO. 1935/2004, DETECTABLE	-	-

SELECTION OF MATERIALS

Material	EPDM	NBR	HNBR	SILICONE/FDA-COMPLIANT SILICONE/ DETECTABLE FDA-COMPLIANT SILICONE	POLYURETHANE
Wear resistance	Fair	Excellent	Excellent	Good	Excellent
Oils	Poor	Excellent	Excellent	Poor	Excellent
Weather and ozone	Excellent	Poor	Excellent	Excellent	Excellent
Hydrolysis	Good	Good	Good	Fair	Poor
Petrol	Poor	Good	Excellent	Poor	Poor
Concentrated acids	Poor	Poor	Good	Poor	Poor
Alcohol	Excellent	Good	Good	Good	Good
Oxidation	Excellent	Good	Excellent	Excellent	Good

AVAILABILITY OF DIAMETERS, MATERIALS AND BELLOWS

Type of suction cup	Material	Diameter (in.)	Number of bellows
VG.U	EPDM, HNBR, SIL, SIL FDA	6, 9, 11, 16, 22, 33, 42, 53	0
VG.B	EPDM, HNBR, NBR, SIL, SIL FDA	6, 9, 11, 16, 22, 33, 42, 53, 77	1
VG.B.SFO	SIL FDA	16, 22, 33, 42, 53	1
VG.CF	NBR 60, HNBR, SIL	16, 22, 27, 33, 42, 53, 77, 112, 152	0
VG.LB	NBR, HNBR, SIL FDA	6, 9, 11, 16, 22, 33, 42, 53	2
VG.LB.SFO	SIL FDA	16, 22, 33, 42, 53	2
VG.FP	SIL, SIL FDA	15, 20, 30, 40	4
VG.BC	SIL	40, 50	3
VG.SBC	SIL	40, 50, 63	2
VG.MB	NBR 60	52, 63, 83, 103	1
VG.PAAT	PTFE	16, 20, 30, 40	0
VG.BP	PU50, PU30/70	10, 15, 20, 25, 35, 52, 75	1
VG.IS	PU30/60	20, 25, 35, 45, 55, 70	1
VG.BR	PU50	20x45, 30x55	1
VG.LBR	PU50	20x45, 30x55	2
VG.MF	PU40	20, 30, 45, 60, 80, 100, 120	0
VG.BPG	SIL FDA	30, 41, 48, 55	1
VG.LPG	SIL FDA	30, 41, 48	3
VG.FO	SIL FDA	26, 33	0
VG.BDT	SIL FDA, Detectable	40	4

Suction cups / Silicone

VG.U6S flat silicone suction cups

- Silicone compound
- Suitable for high working temperatures
- Suitable for objects with flat or slightly curved surfaces

Application example

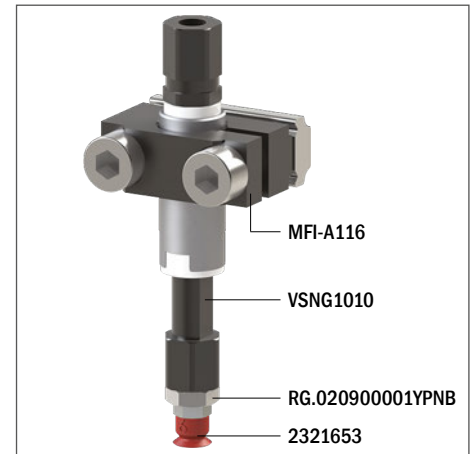

Technical data

Material	Lifting force [N] perpendicular to the surface, at various vacuum levels			Lifting force [N] parallel to the surface, at various vacuum levels			Volume [cm ³]	Min curve radius [mm]	Max vert. movement [mm]	Suction cup weight [g]
	-20 kPa	-60 kPa	-90 kPa	-20 kPa	-60 kPa	-90 kPa				
SIL 50	0.5	1.5	2.5	0.5	1.3	2.2	0.05	5	0.3	0.1

Technical features

Material	Color	Hardness	Temperature range
Silicone, SIL	Red	50 Shore	-94 - +392 °F

Ordering information

Drawing	Alphanumeric code	Suction cups with fitting	Order code
A	VG.U6S.50.M3M.E5	VG.U6 suction cup, silicone, 50 Shore, M3 male, 5 mm hex	2321653
B	VG.U6S.50.M5M.E8	VG.U6 suction cup, silicone, 50 Shore, M5 male, 8 mm hex	2321053



Click for Pricing & Add to Cart

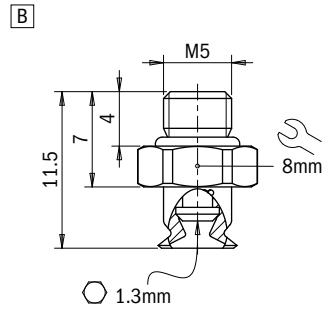
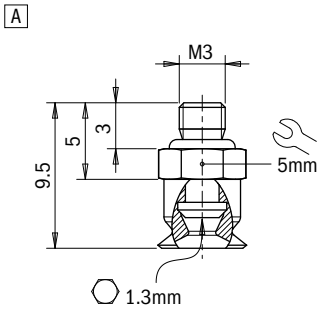

Ordering information

Drawing	Alphanumeric code	Suction cups	Order code
A	VG.U6S.50	VG.U6 suction cup, silicone, 50 Shore	2321654

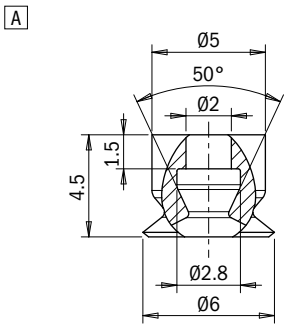

Ordering information

Drawing	Alphanumeric code	Fittings	Order code
A	FT.M3M.E5	M3 male fitting, 5 mm hex	2321402
B	FT.M5M.E8.06	M5 male fitting, 8 mm hex	2321005

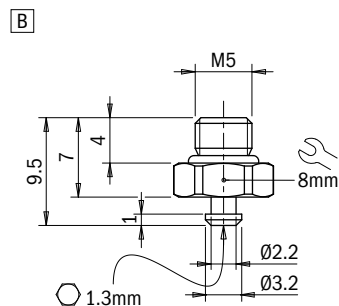
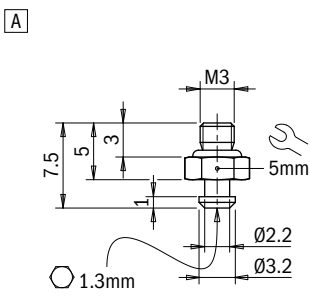

Suction cups / Silicone

VG.U9S flat silicone suction cups

- Silicone compound
- Suitable for high working temperatures
- Suitable for objects with flat or slightly curved surfaces



Application example

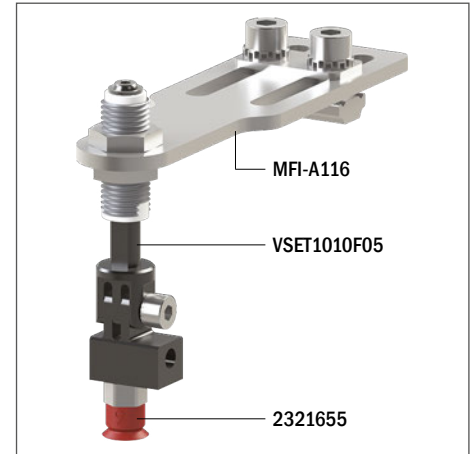

Technical data

Material	Lifting force [N] perpendicular to the surface, at various vacuum levels			Lifting force [N] parallel to the surface, at various vacuum levels			Volume [cm ³]	Min curve radius [mm]	Max vert. movement [mm]	Suction cup weight [g]
	-20 kPa	-60 kPa	-90 kPa	-20 kPa	-60 kPa	-90 kPa				
SIL 50	1	2.5	3.8	1	2.5	3.5	0.1	6	0.5	0.2

Technical features

Material	Color	Hardness	Temperature range
Silicone, SIL	Red	50 Shore	-94 - +392 °F

Ordering information			
Drawing	Alphanumeric code	Suction cups with fitting	Order code
A	VG.U9S.50.M5M.E8	VG.U9 suction cup, silicone, 50 Shore, M5 male, 8 mm hex	2321655

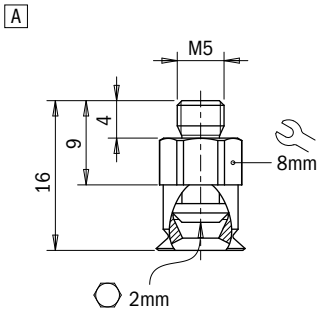

Ordering information			
Drawing	Alphanumeric code	Suction cups	Order code
A	VG.U9S.50	VG.U9 suction cup, silicone, 50 Shore	2321656

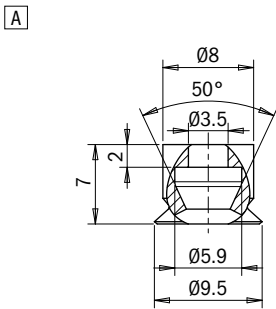

Ordering information			
Drawing	Alphanumeric code	Fittings	Order code
A	FT.M5M.E8.05	M5 male fitting, 8 mm hex	2321405

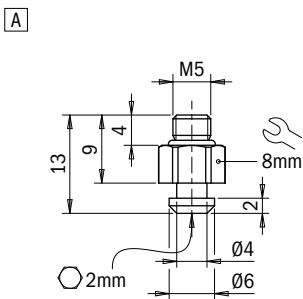

Suction cups / Silicone

VG.U11S flat silicone suction cups

- Silicone compound
- Suitable for high working temperatures
- Suitable for objects with flat or slightly curved surfaces

Introduction

Vacuum theory

Suction cups

Vacuum pumps

Customised solutions

Suspensions

System accessories



Application example

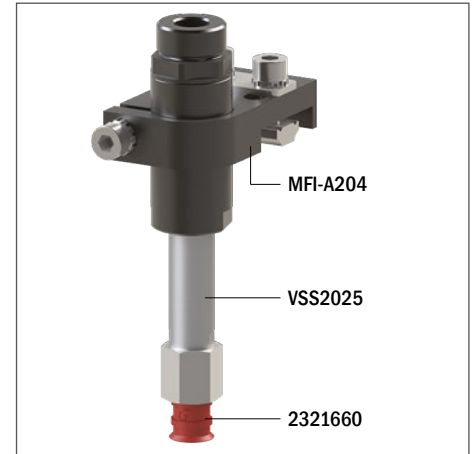

Technical data

Material	Lifting force [N] perpendicular to the surface, at various vacuum levels			Lifting force [N] parallel to the surface, at various vacuum levels			Volume [cm ³]	Min curve radius [mm]	Max vert. movement [mm]	Suction cup weight [g]
	-20 kPa	-60 kPa	-90 kPa	-20 kPa	-60 kPa	-90 kPa				
SIL 50	1.5	4.1	6.2	1.5	4.1	6.2	0.18	8	0.5	0.5

Technical features

Material	Color	Hardness	Temperature range
Silicone, SIL	Red	50 Shore	-94 - +392 °F

Ordering information			
Drawing	Alphanumeric code	Suction cups with fitting	Order code
A	VG.U11S.50.M5F.E8	VG.U11 suction cup, silicone, 50 Shore, M5 female, 8 mm hex	2321657
B	VG.U11S.50.M5M.E8	VG.U11 suction cup, silicone, 50 Shore, M5 male, 8 mm hex	2321659
C	VG.U11S.50.G18F.E13	VG.U11 suction cup, silicone, 50 Shore, G1/8" female, 13 mm hex	2321660
D	VG.U11S.50.G18M.E13	VG.U11 suction cup, silicone, 50 Shore, G1/8" male, 13 mm hex	2321661

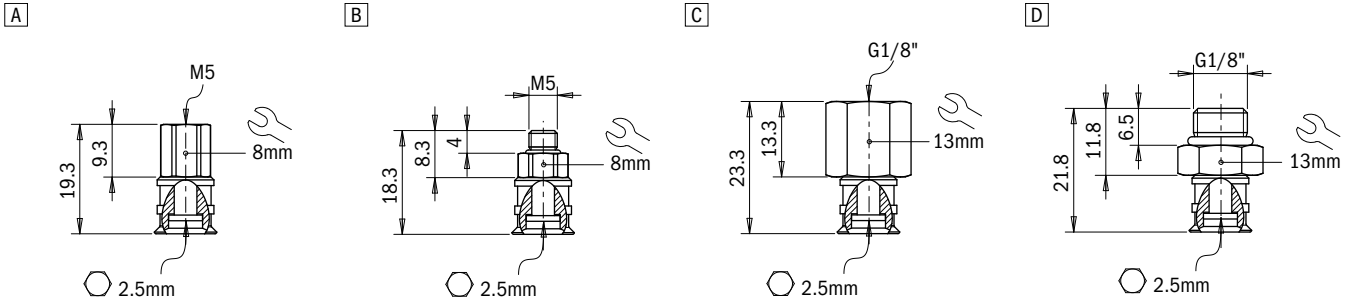

Ordering information			
Drawing	Alphanumeric code	Suction cups	Order code
A	VG.U11S.50	VG.U11 suction cup, silicone, 50 Shore	2321658

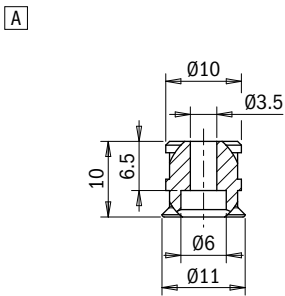

Ordering information			
Drawing	Alphanumeric code	Fittings	Order code
A	FT.M5F.E8	M5 female fitting, 8 mm hex	2321408
B	FT.M5M.E8	M5 male fitting, 8 mm hex	2321410
C	FT.G18F.E13	G1/8" female fitting, 13 mm hex	2321412
D	FT.G18M.E13	G1/8" male fitting, 13 mm hex	2321414

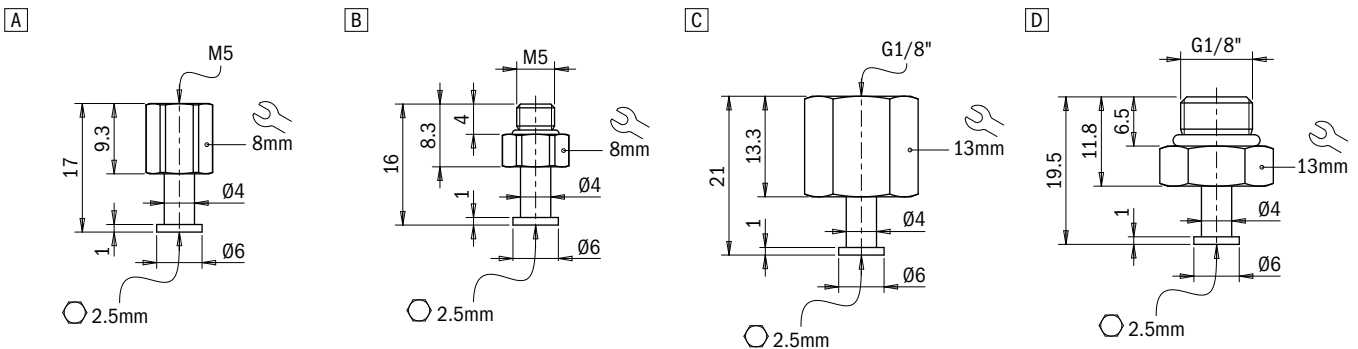

Suction cups / Silicone

VG.U16S flat silicone suction cups

- Silicone compound
- Suitable for high working temperatures
- Suitable for objects with flat or slightly curved surfaces



Application example



Technical data

Material	Lifting force [N] perpendicular to the surface, at various vacuum levels			Lifting force [N] parallel to the surface, at various vacuum levels			Volume [cm ³]	Min curve radius [mm]	Max vert. movement [mm]	Suction cup weight [g]
	-20 kPa	-60 kPa	-90 kPa	-20 kPa	-60 kPa	-90 kPa				
SIL 50	3	8.5	11	3	8.5	11	0.5	8	1.5	0.6

Technical features

Material	Color	Hardness	Temperature range
Silicone, SIL	Red	50 Shore	-94 - +392 °F

Ordering information

Drawing	Alphanumeric code	Suction cups with fitting	Order code
A	VG.U16S.50.M5F.E8	VG.U16 suction cup, silicone, 50 Shore, M5 female, 8 mm hex	2321662
B	VG.U16S.50.M5M.E8	VG.U16 suction cup, silicone, 50 Shore, M5 male, 8 mm hex	2321664
C	VG.U16S.50.G18F.E13	VG.U16 suction cup, silicone, 50 Shore, G1/8" female, 13 mm hex	2321665
D	VG.U16S.50.G18M.E13	VG.U16 suction cup, silicone, 50 Shore, G1/8" male, 13 mm hex	2321666

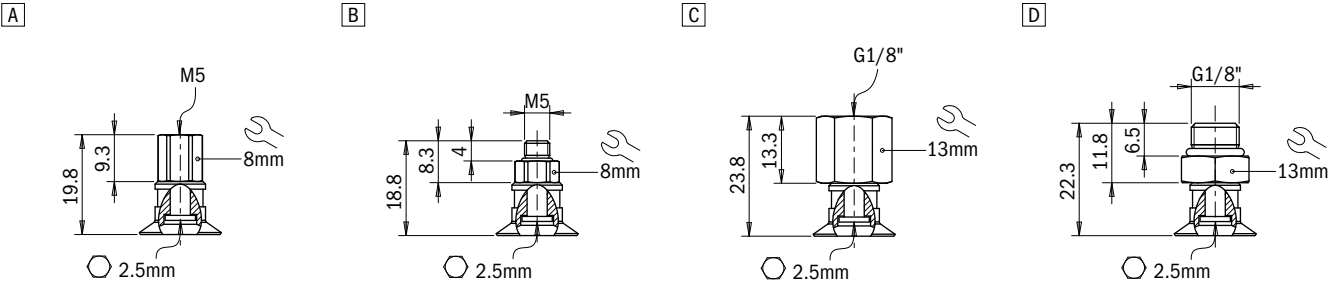

Identification codes

Drawing	Alphanumeric code	Suction cups	Order code
A	VG.U16S.50	VG.U16 suction cup, silicone, 50 Shore	2321663

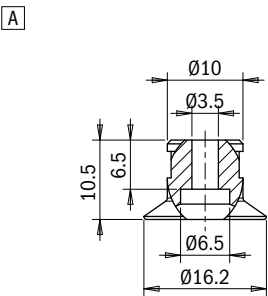

Identification codes

Drawing	Alphanumeric code	Fittings	Order code
A	FT.M5F.E8	M5 female fitting, 8 mm hex	2321408
B	FT.M5M.E8	M5 male fitting, 8 mm hex	2321410
C	FT.G18F.E13	G1/8" female fitting, 13 mm hex	2321412
D	FT.G18M.E13	G1/8" male fitting, 13 mm hex	2321414

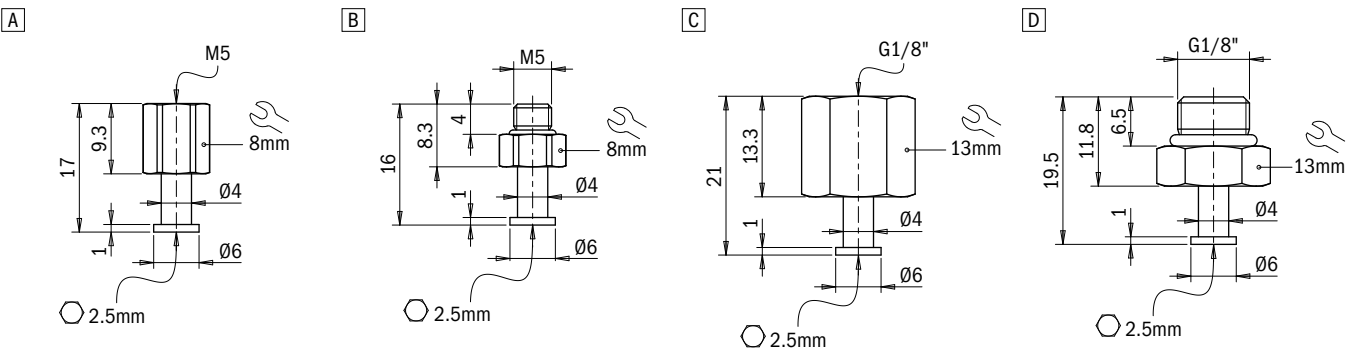

Suction cups / Silicone

VG.U22S flat silicone suction cups

- Silicone compound
- Suitable for high working temperatures
- Suitable for objects with flat or slightly curved surfaces



Application example



Technical data

Material	Lifting force [N] perpendicular to the surface, at various vacuum levels			Lifting force [N] parallel to the surface, at various vacuum levels			Volume [cm ³]	Min curve radius [mm]	Max vert. movement [mm]	Suction cup weight [g]
	-20 kPa	-60 kPa	-90 kPa	-20 kPa	-60 kPa	-90 kPa				
SIL 50	5.6	14	20	6	14	20	1	13	2.5	1.1

Technical features

Material	Color	Hardness	Temperature range
Silicone, SIL	Red	50 Shore	-94 - +392 °F

Ordering information

Drawing	Alphanumeric code	Suction cups with fitting	Order code
A	VG.U22S.50.G18F.E12	VG.U22 suction cup, silicone, 50 Shore, G1/8" female, 12 mm hex	2321667
B	VG.U22S.50.G18M.E12	VG.U22 suction cup, silicone, 50 Shore, G1/8" male, 12 mm hex	2321669
C	VG.U22S.50.G18F.E16	VG.U22 suction cup, silicone, 50 Shore, G1/8" female, 16 mm hex	2321670
D	VG.U22S.50.G18M.E16	VG.U22 suction cup, silicone, 50 Shore, G1/8" male, 16 mm hex	2321671
E	VG.U22S.50.G14F.E16	VG.U22 suction cup, silicone, 50 Shore, G1/4" female, 16 mm hex	2321672
F	VG.U22S.50.G14M.E17	VG.U22 suction cup, silicone, 50 Shore, G1/4" male, 17 mm hex	2321673

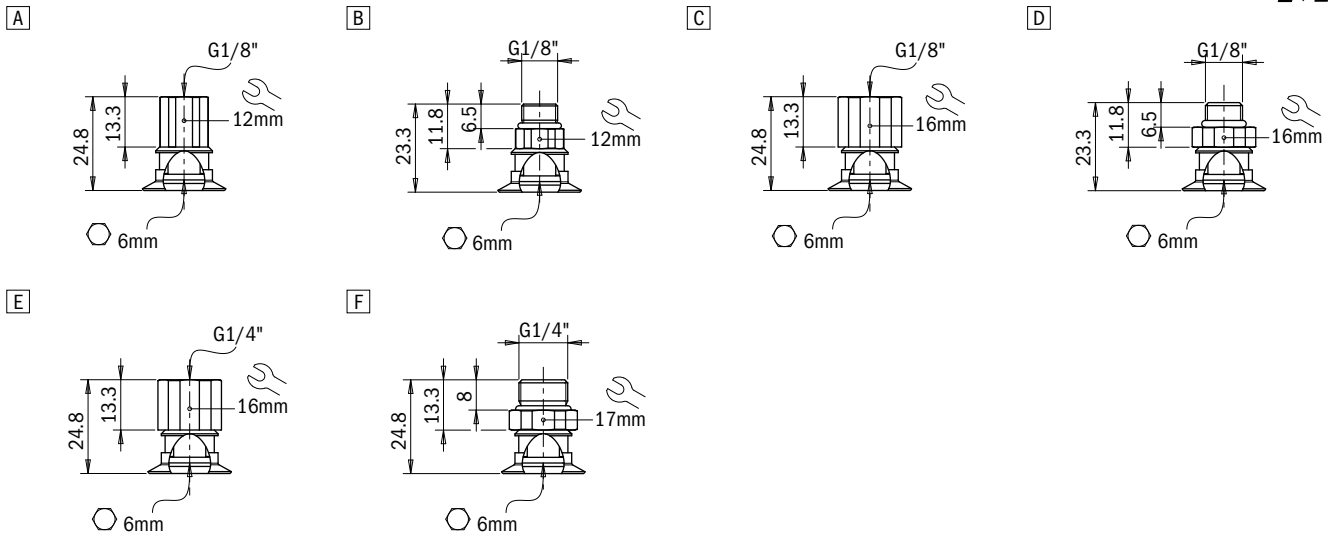

Ordering information

Drawing	Alphanumeric code	Suction cups	Order code
A	VG.U22S.50	VG.U22 suction cup, silicone, 50 Shore	2321668

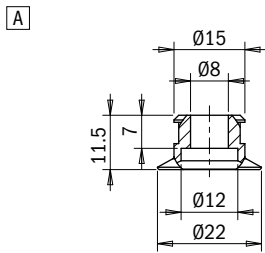

Ordering information

Drawing	Alphanumeric code	Fittings	Order code
A	FT.G18F.E12	G1/8" female fitting, 12 mm hex	2321422
B	FT.G18M.E12	G1/8" male fitting, 12 mm hex	2321424
C	FT.G18F.E16	G1/8" female fitting, 16 mm hex	2321426
D	FT.G18M.E16	G1/8" male fitting, 16 mm hex	2321428
E	FT.G14F.E16	G1/4" female fitting, 16 mm hex	2321430
F	FT.G14M.E17	G1/4" male fitting, 17 mm hex	2321432

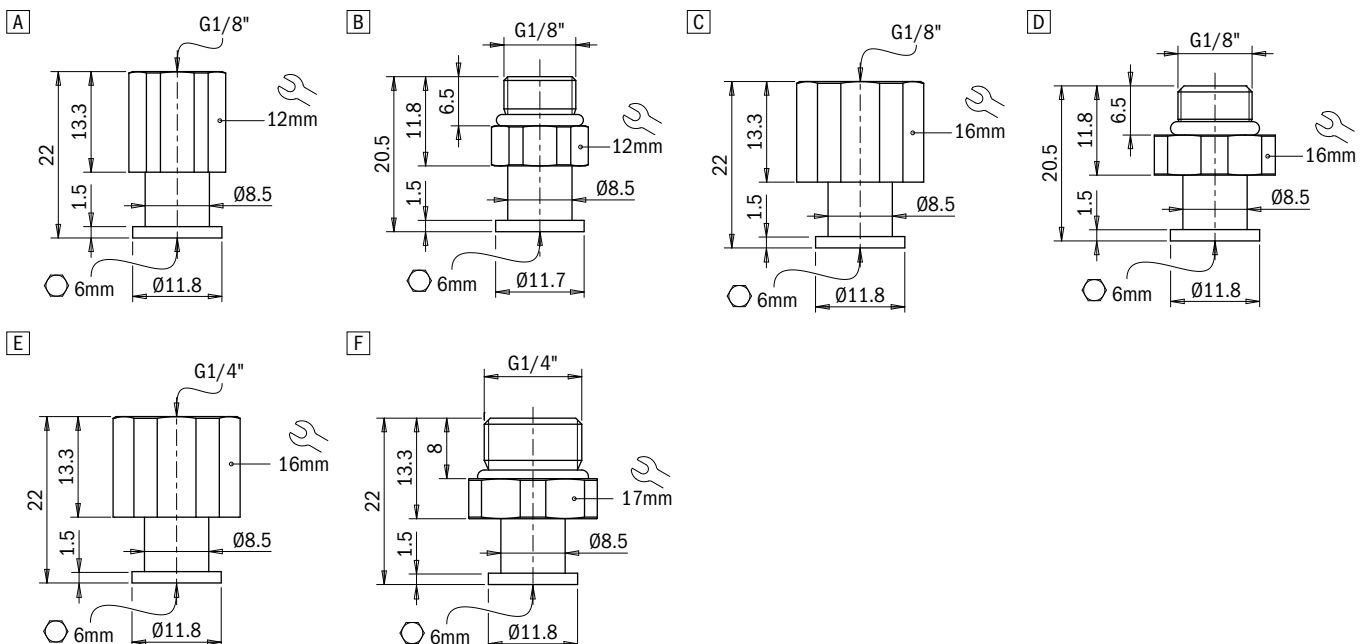

Suction cups / Silicone

VG.U33S flat silicone suction cups

- Silicone compound
- Suitable for high working temperatures
- Suitable for objects with flat or slightly curved surfaces

Application example

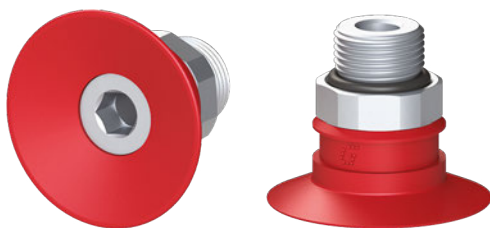
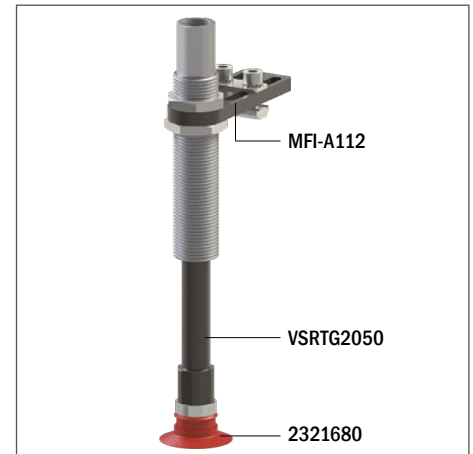

Technical data

Material	Lifting force [N] perpendicular to the surface, at various vacuum levels			Lifting force [N] parallel to the surface, at various vacuum levels			Volume [cm ³]	Min curve radius [mm]	Max vert. movement [mm]	Suction cup weight [g]
	-20 kPa	-60 kPa	-90 kPa	-20 kPa	-60 kPa	-90 kPa				
SIL 50	11	29	38	8.5	15	12.5	2	20	3.5	2.4

Technical features

Material	Color	Hardness	Temperature range
Silicone, SIL	Red	50 Shore	-94 - +392 °F

Ordering information

Drawing	Alphanumeric code	Suction cups with fitting	Order code
A	VG.U33S.50.G18F.E12	VG.U33 suction cup, silicone, 50 Shore, G1/8" female, 12 mm hex	2321674
B	VG.U33S.50.G18M.E12	VG.U33 suction cup, silicone, 50 Shore, G1/8" male, 12 mm hex	2321676
C	VG.U33S.50.G18F.E16	VG.U33 suction cup, silicone, 50 Shore, G1/8" female, 16 mm hex	2321677
D	VG.U33S.50.G18M.E16	VG.U33 suction cup, silicone, 50 Shore, G1/8" male, 16 mm hex	2321678
E	VG.U33S.50.G14F.E16	VG.U33 suction cup, silicone, 50 Shore, G1/4" female, 16 mm hex	2321679
F	VG.U33S.50.G14M.E17	VG.U33 suction cup, silicone, 50 Shore, G1/4" male, 17 mm hex	2321680

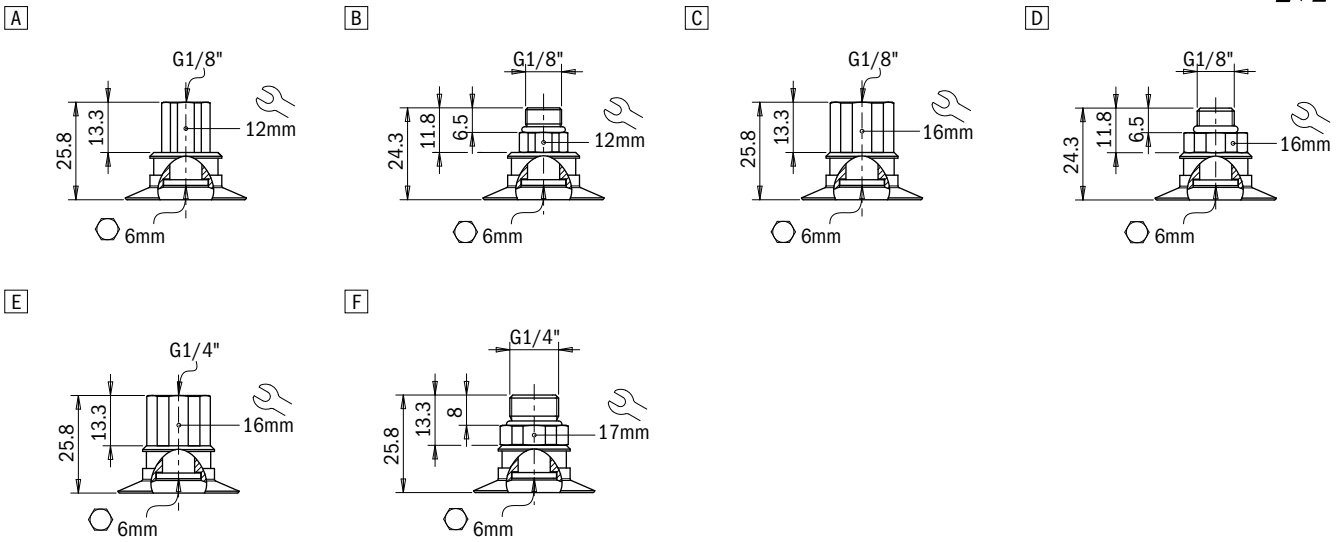

Ordering information

Drawing	Alphanumeric code	Suction cups	Order code
A	VG.U33S.50	VG.U33 suction cup, silicone, 50 Shore	2321675



Click for Pricing & Add to Cart

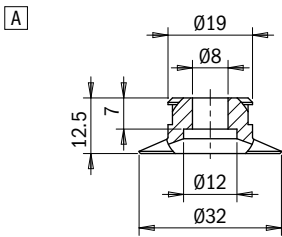

Ordering information

Drawing	Alphanumeric code	Fittings	Order code
A	FT.G18F.E12	G1/8" female fitting, 12 mm hex	2321422
B	FT.G18M.E12	G1/8" male fitting, 12 mm hex	2321424
C	FT.G18F.E16	G1/8" female fitting, 16 mm hex	2321426
D	FT.G18M.E16	G1/8" male fitting, 16 mm hex	2321428
E	FT.G14F.E16	G1/4" female fitting, 16 mm hex	2321430
F	FT.G14M.E17	G1/4" male fitting, 17 mm hex	2321432

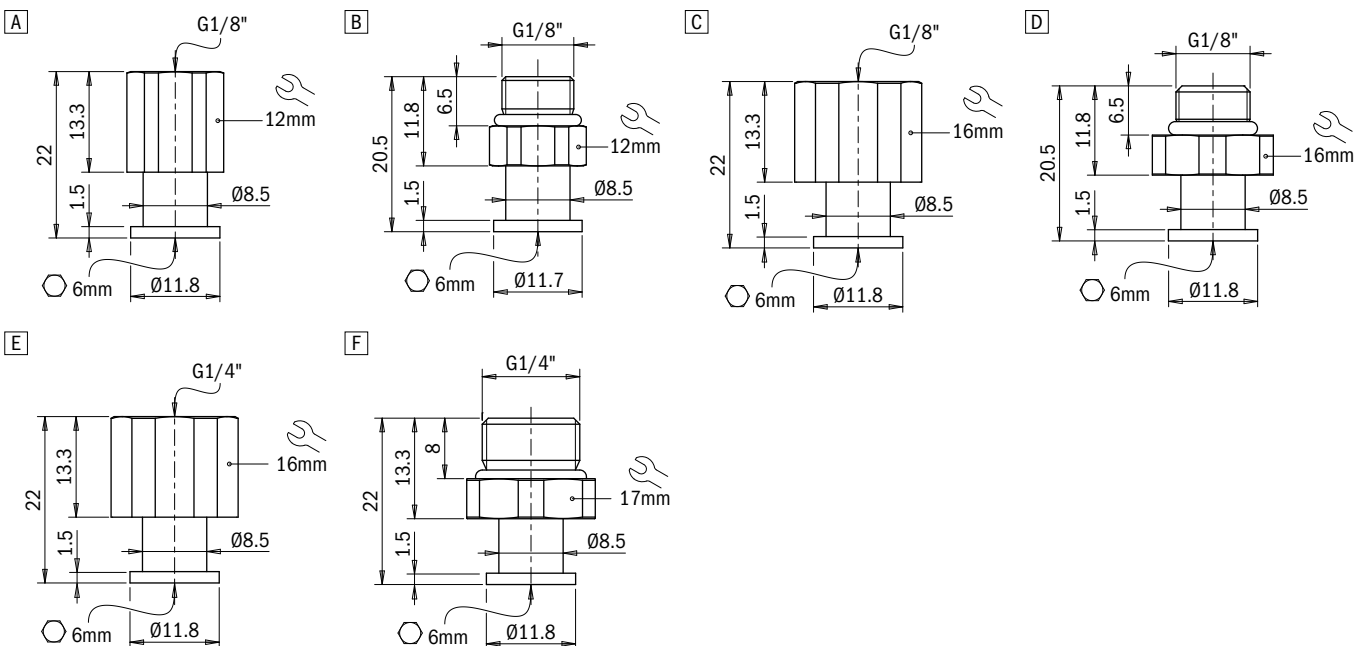

Suction cups / Silicone

VG.U42S flat silicone suction cups

- Silicone compound
- Suitable for high working temperatures
- Suitable for objects with flat or slightly curved surfaces



Application example

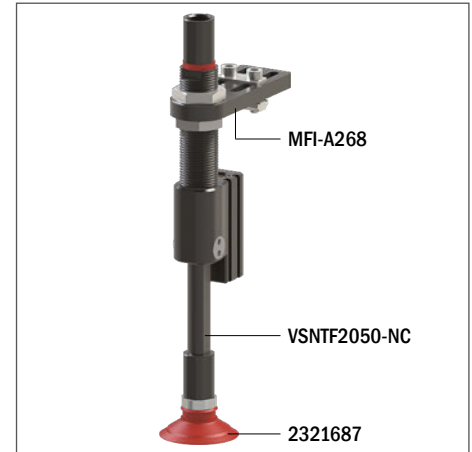

Technical data

Material	Lifting force [N] perpendicular to the surface, at various vacuum levels			Lifting force [N] parallel to the surface, at various vacuum levels			Volume [cm ³]	Min curve radius [mm]	Max vert. movement [mm]	Suction cup weight [g]
	-20 kPa	-60 kPa	-90 kPa	-20 kPa	-60 kPa	-90 kPa				
SIL 50	21	48.5	58	14	28	36	5.5	30	4.5	4.4

Technical features

Material	Color	Hardness	Temperature range
Silicone, SIL	Red	50 Shore	-94 - +392 °F

Ordering information

Drawing	Alphanumeric code	Suction cups with fitting	Order code
A	VG.U42S.50.G18F.E12	VG.U42 suction cup, silicone, 50 Shore, G1/8" female, 12 mm hex	2321681
B	VG.U42S.50.G18M.E12	VG.U42 suction cup, silicone, 50 Shore, G1/8" male, 12 mm hex	2321683
C	VG.U42S.50.G18F.E16	VG.U42 suction cup, silicone, 50 Shore, G1/8" female, 16 mm hex	2321684
D	VG.U42S.50.G18M.E16	VG.U42 suction cup, silicone, 50 Shore, G1/8" male, 16 mm hex	2321685
E	VG.U42S.50.G14F.E16	VG.U42 suction cup, silicone, 50 Shore, G1/4" female, 16 mm hex	2321686
F	VG.U42S.50.G14M.E17	VG.U42 suction cup, silicone, 50 Shore, G1/4" male, 17 mm hex	2321687

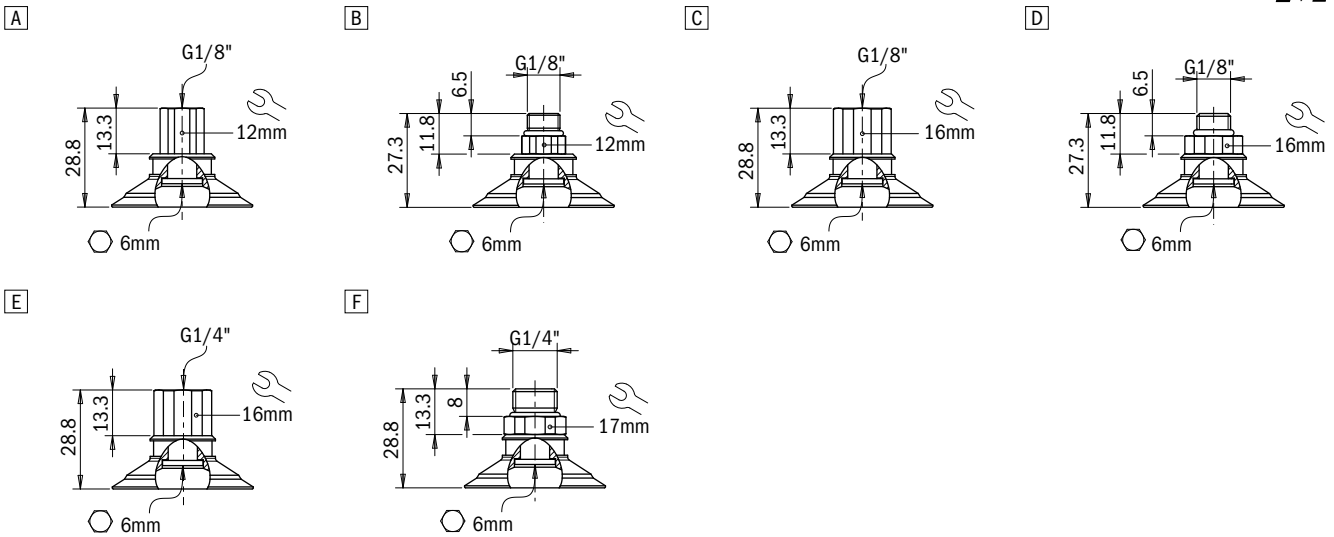

Ordering information

Drawing	Alphanumeric code	Suction cups	Order code
A	VG.U42S.50	VG.U42 suction cup, silicone, 50 Shore	2321682

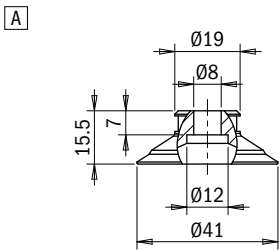

Ordering information

Drawing	Alphanumeric code	Fittings	Order code
A	FT.G18F.E12	G1/8" female fitting, 12 mm hex	2321422
B	FT.G18M.E12	G1/8" male fitting, 12 mm hex	2321424
C	FT.G18F.E16	G1/8" female fitting, 16 mm hex	2321426
D	FT.G18M.E16	G1/8" male fitting, 16 mm hex	2321428
E	FT.G14F.E16	G1/4" female fitting, 16 mm hex	2321430
F	FT.G14M.E17	G1/4" male fitting, 17 mm hex	2321432

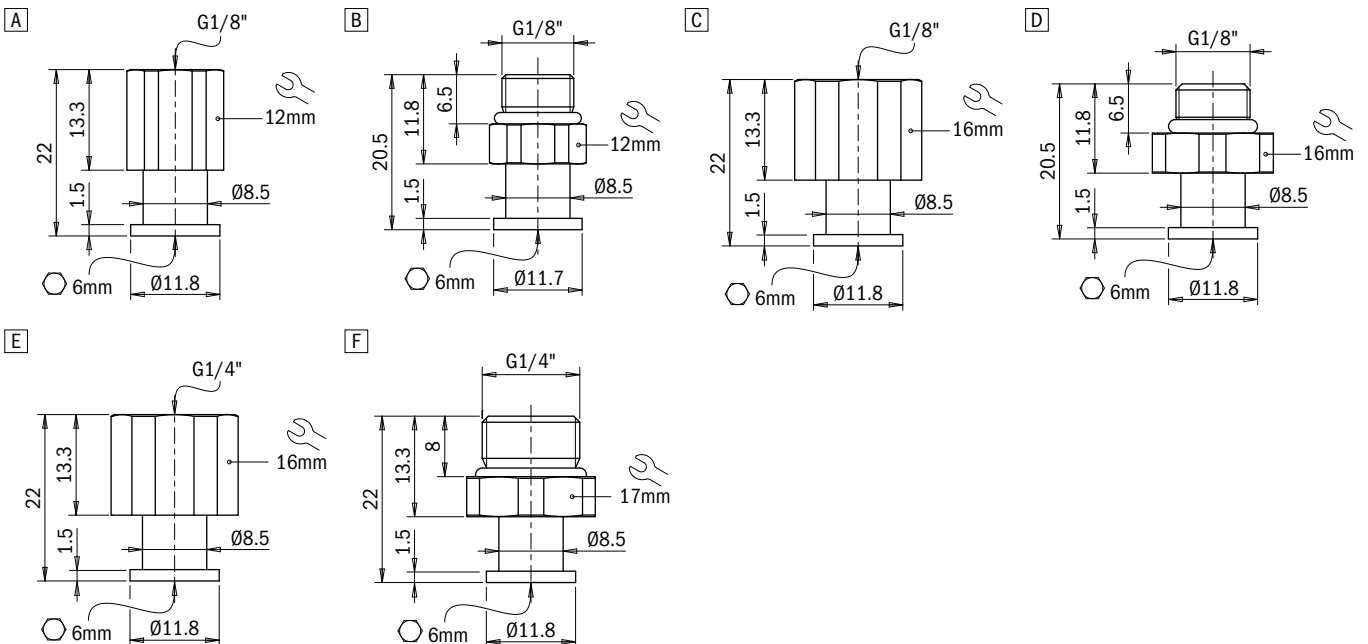

Suction cups / Silicone

VG.U53S flat silicone suction cups

- Silicone compound
- Suitable for high working temperatures
- Suitable for objects with flat or slightly curved surfaces

Application example



Technical data

Material	Lifting force [N] perpendicular to the surface, at various vacuum levels			Lifting force [N] parallel to the surface, at various vacuum levels			Volume [cm ³]	Min curve radius [mm]	Max vert. movement [mm]	Suction cup weight [g]
	-20 kPa	-60 kPa	-90 kPa	-20 kPa	-60 kPa	-90 kPa				
SIL 50	37	75	96	20	35	46	12	35	6	7.9

Technical features

Material	Color	Hardness	Temperature range
Silicone, SIL	Red	50 Shore	-94 - +392 °F

Ordering information

Drawing	Alphanumeric code	Suction cups with fitting	Order code
A	VG.U53S.50.G18F.E12	VG.U53 suction cup, silicone, 50 Shore, G1/8" female, 12 mm hex	2321688
B	VG.U53S.50.G18M.E12	VG.U53 suction cup, silicone, 50 Shore, G1/8" male, 12 mm hex	2321690
C	VG.U53S.50.G18F.E16	VG.U53 suction cup, silicone, 50 Shore, G1/8" female, 16 mm hex	2321691
D	VG.U53S.50.G18M.E16	VG.U53 suction cup, silicone, 50 Shore, G1/8" male, 16 mm hex	2321692
E	VG.U53S.50.G14F.E16	VG.U53 suction cup, silicone, 50 Shore, G1/4" female, 16 mm hex	2321693
F	VG.U53S.50.G14M.E17	VG.U53 suction cup, silicone, 50 Shore, G1/4" male, 17 mm hex	2321694

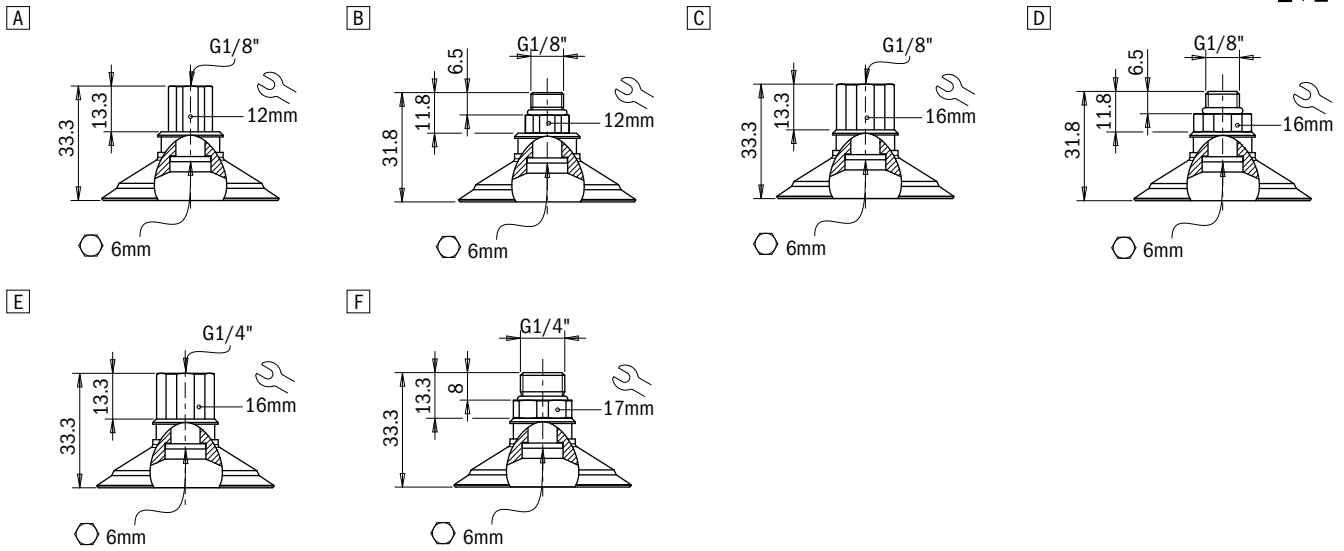

Ordering information

Drawing	Alphanumeric code	Suction cups	Order code
A	VG.U53S.50	VG.U53 suction cup, silicone, 50 Shore	2321689

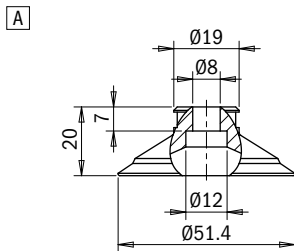

Ordering information

Drawing	Alphanumeric code	Fittings	Order code
A	FT.G18F.E12	G1/8" female fitting, 12 mm hex	2321422
B	FT.G18M.E12	G1/8" male fitting, 12 mm hex	2321424
C	FT.G18F.E16	G1/8" female fitting, 16 mm hex	2321426
D	FT.G18M.E16	G1/8" male fitting, 16 mm hex	2321428
E	FT.G14F.E16	G1/4" female fitting, 16 mm hex	2321430
F	FT.G14M.E17	G1/4" male fitting, 17 mm hex	2321432

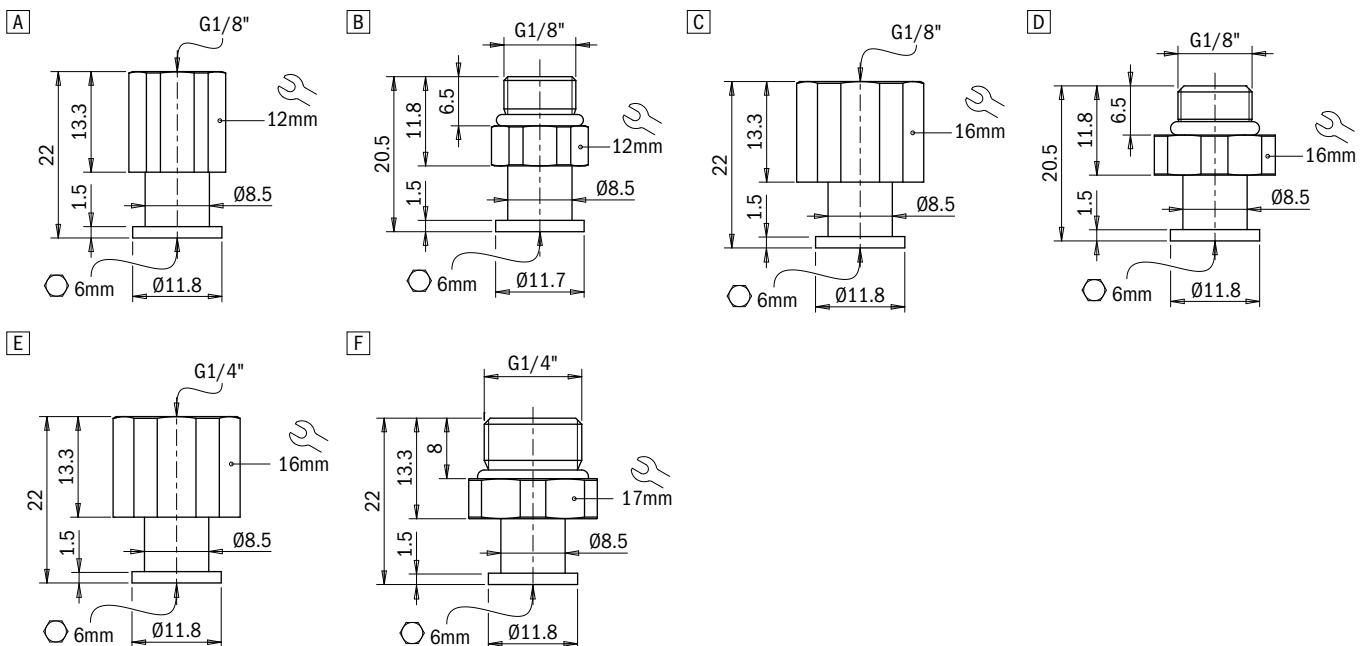

Suction cups / EPDM-HNBR

VG.U6 flat EPDM-HNBR suction cups

- Suitable for handling plastic parts
- Suitable for objects with flat or slightly curved surfaces
- The HNBR version enables to work at high temperatures, whereas silicone or other mixtures may release traces of material. Ideal for applications where contamination of the material must be avoided (PWIS)
- The HNBR compound is robust and wear resistant, suitable for the removal of hot plastic parts from the relevant moulds

Application example

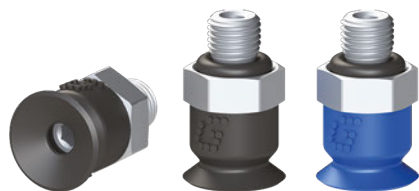
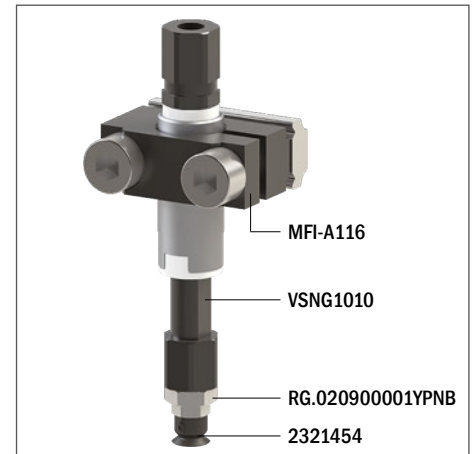

Technical data

Material	Lifting force [N] perpendicular to the surface, at various vacuum levels			Lifting force [N] parallel to the surface, at various vacuum levels			Volume [cm ³]	Min curve radius [mm]	Max vert. movement [mm]	Suction cup weight [g]
	-20 kPa	-60 kPa	-90 kPa	-20 kPa	-60 kPa	-90 kPa				
EPDM 50	0.5	1.5	2.5	0.5	1.3	2.2	0.05	5	0.3	0.1
HNBR 60	0.5	1.5	2.5	0.5	1.3	2.2	0.05	5	0.3	0.1

Technical features

Material	Color	Hardness	Temperature range
EPDM	Black	50 Shore	-40 - +212 °F
HNBR	Blue	60 Shore	-13 - +302 °F

Identification codes

Drawing	Alphanumeric code	Suction cups with fitting	Order code
A	VG.U6E.50.M3M.E5	VG.U6 suction cup, EPDM, 50 Shore, M3 male, 5 mm hex	2321454
A	VG.U6H.60.M3M.E5	VG.U6 suction cup, HNBR, 60 Shore, M3 male, 5 mm hex	2321456
B	VG.U6E.50.M5M.E8	VG.U6 suction cup, EPDM, 50 Shore, M5 male, 8 mm hex	2321054
B	VG.U6H.60.M5M.E8	VG.U6 suction cup, HNBR, 60 Shore, M5 male, 8 mm hex	2321056

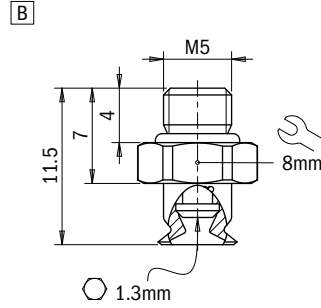
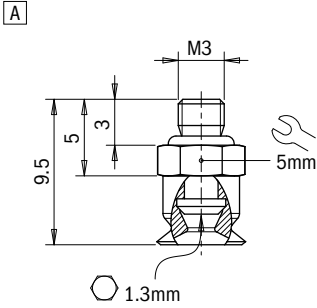

Identification codes

Drawing	Alphanumeric code	Suction cups	Order code
A	VG.U6E.50	VG.U6 suction cup, EPDM, 50 Shore	2321455
A	VG.U6H.60	VG.U6 suction cup, HNBR, 60 Shore	2321457

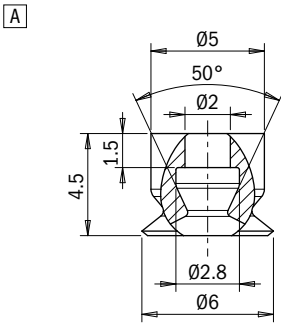

Identification codes

Drawing	Alphanumeric code	Fittings	Order code
A	FT.M3M.E5	M3 male fitting, 5 mm hex	2321402
B	FT.M5M.E8.06	M5 male fitting, 8 mm hex	2321005

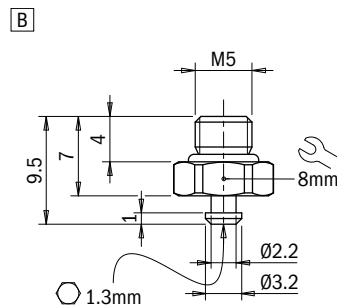
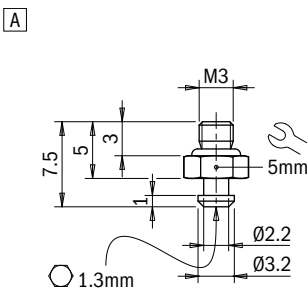

Suction cups / EPDM-HNBR

VG.U9 flat EPDM-HNBR suction cups

- Suitable for handling plastic parts
- Suitable for objects with flat or slightly curved surfaces
- The HNBR version enables to work at high temperatures, whereas silicone or other mixtures may release traces of material. Ideal for applications where contamination of the material must be avoided (PWIS)
- The HNBR compound is robust and wear resistant, suitable for the removal of hot plastic parts from the relevant moulds



Application example

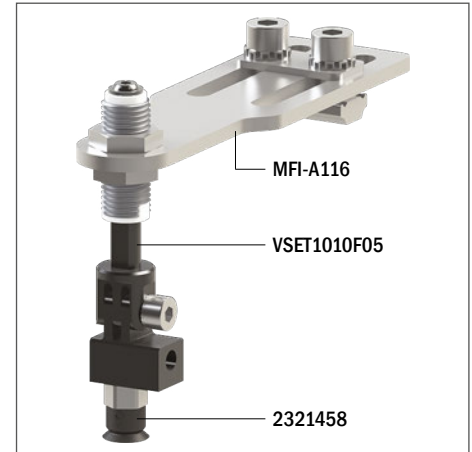

Technical data

Material	Lifting force [N] perpendicular to the surface, at various vacuum levels			Lifting force [N] parallel to the surface, at various vacuum levels			Volume [cm ³]	Min curve radius [mm]	Max vert. movement [mm]	Suction cup weight [g]
	-20 kPa	-60 kPa	-90 kPa	-20 kPa	-60 kPa	-90 kPa				
EPDM 50	1	2.5	3.8	1	2.5	3.5	0.1	6	0.5	0.2
HNBR 60	1	2.5	3.8	1	2.5	3.5	0.1	6	0.5	0.2

Technical features

Material	Color	Hardness	Temperature range
EPDM	Black	50 Shore	-40 - +212 °F
HNBR	Blue	60 Shore	-13 - +302 °F

Ordering information

Drawing	Alphanumeric code	Suction cups with fitting	Order code
A	VG.U9E.50.M5M.E8	VG.U9 suction cup, EPDM, 50 Shore, M5 male, 8 mm hex	2321458
A	VG.U9H.60.M5M.E8	VG.U9 suction cup, HNBR, 60 Shore, M5 male, 8 mm hex	2321460

A

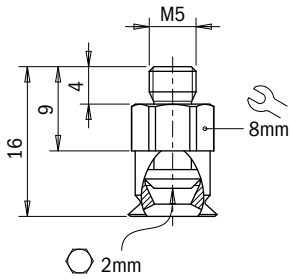

Ordering information

Drawing	Alphanumeric code	Suction cups	Order code
A	VG.U9E.50	VG.U9 suction cup, EPDM, 50 Shore	2321459
A	VG.U9H.60	VG.U9 suction cup, HNBR, 60 Shore	2321461

A

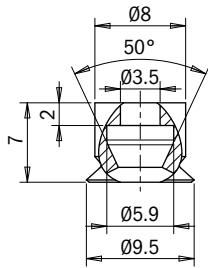

Ordering information

Drawing	Alphanumeric code	Fittings	Order code
A	FT.M5M.E8.05	M5 male fitting, 8 mm hex	2321405

A

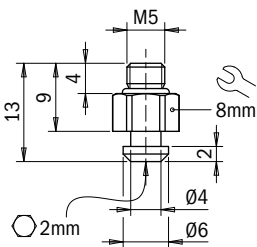

Suction cups / EPDM-HNBR

VG.U11 flat EPDM-HNBR suction cups

- Suitable for handling plastic parts
- Suitable for objects with flat or slightly curved surfaces
- The HNBR version enables to work at high temperatures, whereas silicone or other mixtures may release traces of material. Ideal for applications where contamination of the material must be avoided (PWIS)
- The HNBR compound is robust and wear resistant, suitable for the removal of hot plastic parts from the relevant moulds

Application example



Technical data

Material	Lifting force [N] perpendicular to the surface, at various vacuum levels			Lifting force [N] parallel to the surface, at various vacuum levels			Volume [cm ³]	Min curve radius [mm]	Max vert. movement [mm]	Suction cup weight [g]
	-20 kPa	-60 kPa	-90 kPa	-20 kPa	-60 kPa	-90 kPa				
EPDM 50	1.5	4.1	6.2	1.5	4.1	6.2	0.18	8	0.5	0.5
HNBR 60	1.5	4.1	6.2	1.5	4.1	6.2	0.18	8	0.5	0.5

Technical features

Material	Color	Hardness	Temperature range
EPDM	Black	50 Shore	-40 - +212 °F
HNBR	Blue	60 Shore	-13 - +302 °F

Ordering information

Drawing	Alphanumeric code	Suction cups with fitting	Order code
A	VG.U11E.50.M5F.E8	VG.U11 suction cup, EPDM, 50 Shore, M5 female, 8 mm hex	2321462
B	VG.U11E.50.M5M.E8	VG.U11 suction cup, EPDM, 50 Shore, M5 male, 8 mm hex	2321464
C	VG.U11E.50.G18F.E13	VG.U11 suction cup, EPDM, 50 Shore, G1/8" female, 13 mm hex	2321465
D	VG.U11E.50.G18M.E13	VG.U11 suction cup, EPDM, 50 Shore, G1/8" male, 13 mm hex	2321466
A	VG.U11H.60.M5F.E8	VG.U11 suction cup, HNBR, 60 Shore, M5 female, 8 mm hex	2321467
B	VG.U11H.60.M5M.E8	VG.U11 suction cup, HNBR, 60 Shore, M5 male, 8 mm hex	2321469
C	VG.U11H.60.G18F.E13	VG.U11 suction cup, HNBR, 60 Shore, G1/8" female, 13 mm hex	2321470
D	VG.U11H.60.G18M.E13	VG.U11 suction cup, HNBR, 60 Shore, G1/8" male, 13 mm hex	2321471

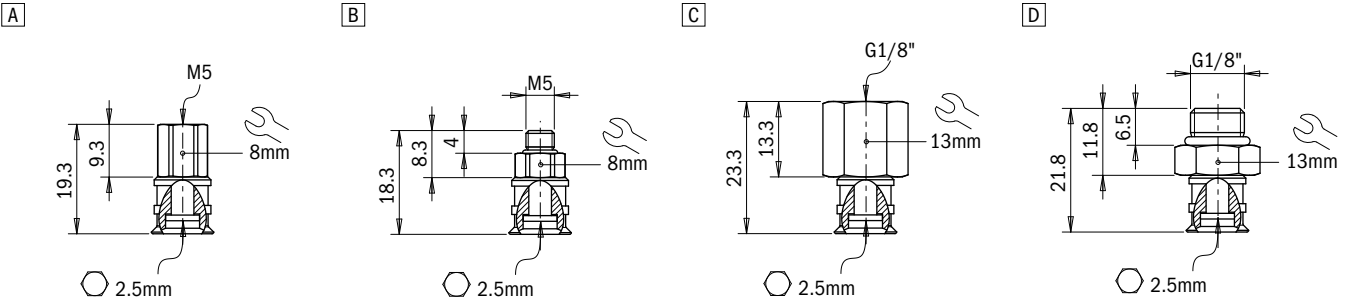

Ordering information

Drawing	Alphanumeric code	Suction cups	Order code
A	VG.U11E.50	VG.U11 suction cup, EPDM, 50 Shore	2321463
A	VG.U11H.60	VG.U11 suction cup, HNBR, 60 Shore	2321468

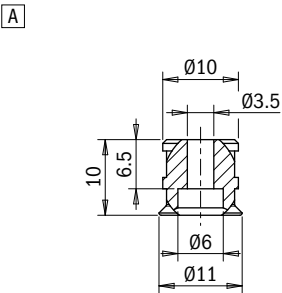

Ordering information

Drawing	Alphanumeric code	Fittings	Order code
A	FT.M5F.E8	M5 female fitting, 8 mm hex	2321408
B	FT.M5M.E8	M5 male fitting, 8 mm hex	2321410
C	FT.G18F.E13	G1/8" female fitting, 13 mm hex	2321412
D	FT.G18M.E13	G1/8" male fitting, 13 mm hex	2321414

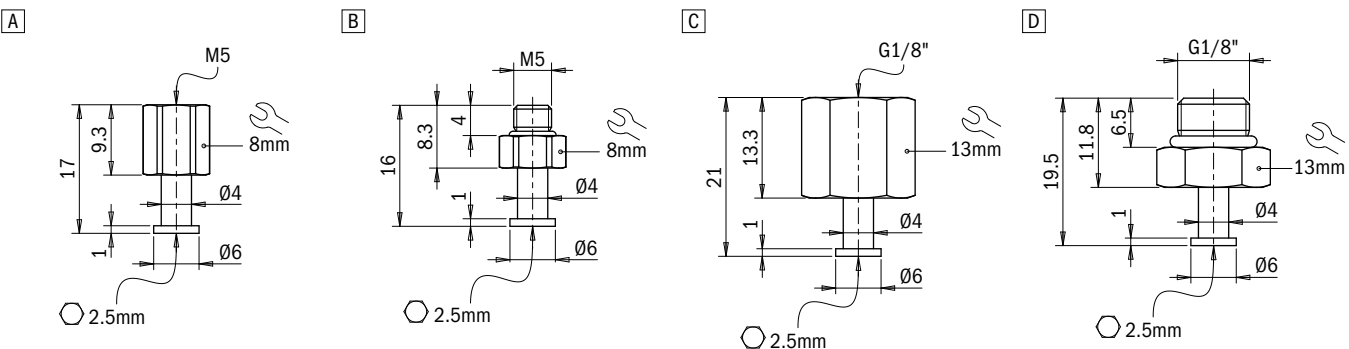

Suction cups / EPDM-HNBR

VG.U16 flat EPDM-HNBR suction cups

- Suitable for handling plastic parts
- Suitable for objects with flat or slightly curved surfaces
- The HNBR version enables to work at high temperatures, whereas silicone or other mixtures may release traces of material. Ideal for applications where contamination of the material must be avoided (PWIS)
- The HNBR compound is robust and wear resistant, suitable for the removal of hot plastic parts from the relevant moulds

Application example

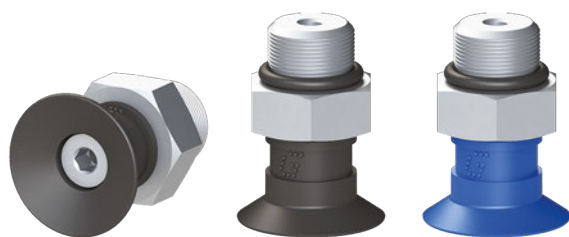

Technical data

Material	Lifting force [N] perpendicular to the surface, at various vacuum levels			Lifting force [N] parallel to the surface, at various vacuum levels			Volume [cm ³]	Min curve radius [mm]	Max vert. movement [mm]	Suction cup weight [g]
	-20 kPa	-60 kPa	-90 kPa	-20 kPa	-60 kPa	-90 kPa				
EPDM 50	3	8.5	11	3	8.5	11	0.5	8	1.5	0.6
HNBR 60	3	8.5	11	3	8.5	11	0.5	8	1.5	0.6

Technical features

Material	Color	Hardness	Temperature range
EPDM	Black	50 Shore	-40 - +212 °F
HNBR	Blue	60 Shore	-13 - +302 °F

Ordering information

Drawing	Alphanumeric code	Suction cups with fitting	Order code
A	VG.U16E.50.M5F.E8	VG.U16 suction cup, EPDM, 50 Shore, M5 female, 8 mm hex	2321472
B	VG.U16E.50.M5M.E8	VG.U16 suction cup, EPDM, 50 Shore, M5 male, 8 mm hex	2321474
C	VG.U16E.50.G18F.E13	VG.U16 suction cup, EPDM, 50 Shore, G1/8" female, 13 mm hex	2321475
D	VG.U16E.50.G18M.E13	VG.U16 suction cup, EPDM, 50 Shore, G1/8" male, 13 mm hex	2321476
A	VG.U16H.60.M5F.E8	VG.U16 suction cup, HNBR, 60 Shore, M5 female, 8 mm hex	2321477
B	VG.U16H.60.M5M.E8	VG.U16 suction cup, HNBR, 60 Shore, M5 male, 8 mm hex	2321479
C	VG.U16H.60.G18F.E13	VG.U16 suction cup, HNBR, 60 Shore, G1/8" female, 13 mm hex	2321480
D	VG.U16H.60.G18M.E13	VG.U16 suction cup, HNBR, 60 Shore, G1/8" male, 13 mm hex	2321481

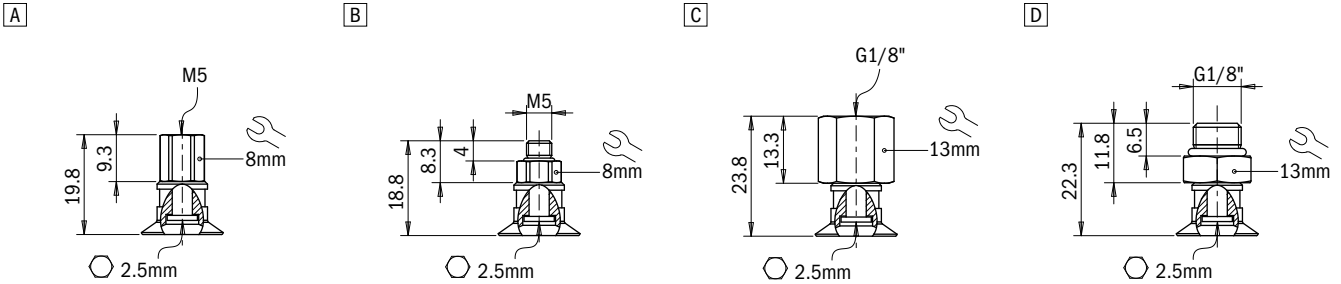

Ordering information

Drawing	Alphanumeric code	Suction cups	Order code
A	VG.U16E.50	VG.U16 suction cup, EPDM, 50 Shore	2321473
A	VG.U16H.60	VG.U16 suction cup, HNBR, 60 Shore	2321478



Click for Pricing & Add to Cart

Ordering information

Drawing	Alphanumeric code	Fittings	Order code
A	FT.M5F.E8	M5 female fitting, 8 mm hex	2321408
B	FT.M5M.E8	M5 male fitting, 8 mm hex	2321410
C	FT.G18F.E13	G1/8" female fitting, 13 mm hex	2321412
D	FT.G18M.E13	G1/8" male fitting, 13 mm hex	2321414

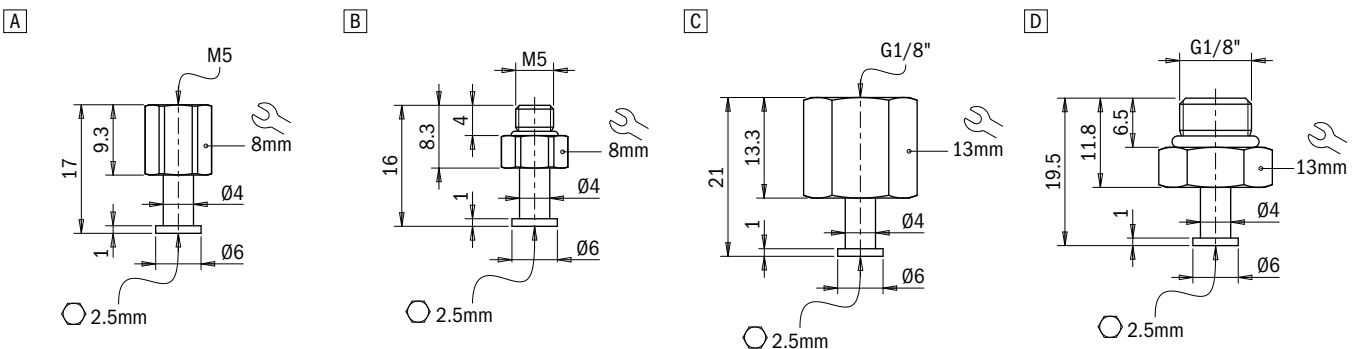

Suction cups / EPDM-HNBR

VG.U22 flat EPDM-HNBR suction cups

- Suitable for handling plastic parts
- Suitable for objects with flat or slightly curved surfaces
- The HNBR version enables to work at high temperatures, whereas silicone or other mixtures may release traces of material. Ideal for applications where contamination of the material must be avoided (PWIS)
- The HNBR compound is robust and wear resistant, suitable for the removal of hot plastic parts from the relevant moulds



Application example



Technical data

Material	Lifting force [N] perpendicular to the surface, at various vacuum levels			Lifting force [N] parallel to the surface, at various vacuum levels			Volume [cm ³]	Min curve radius [mm]	Max vert. movement [mm]	Suction cup weight [g]
	-20 kPa	-60 kPa	-90 kPa	-20 kPa	-60 kPa	-90 kPa				
EPDM 50	5.6	14	20	6	14	20	1	13	2.5	1.1
HNBR 60	5.6	14	20	6	14	20	1	13	2.5	1.1

Technical features

Material	Color	Hardness	Temperature range
EPDM	Black	50 Shore	-40 - +212 °F
HNBR	Blue	60 Shore	-13 - +302 °F

Ordering information

Drawing	Alphanumeric code	Suction cups with fitting	Order code
A	VG.U22E.50.G18F.E12	VG.U22 suction cup, EPDM, 50 Shore, G1/8" female, 12 mm hex	2321482
B	VG.U22E.50.G18M.E12	VG.U22 suction cup, EPDM, 50 Shore, G1/8" male, 12 mm hex	2321484
C	VG.U22E.50.G18F.E16	VG.U22 suction cup, EPDM, 50 Shore, G1/8" female, 16 mm hex	2321485
D	VG.U22E.50.G18M.E16	VG.U22 suction cup, EPDM, 50 Shore, G1/8" male, 16 mm hex	2321486
E	VG.U22E.50.G14F.E16	VG.U22 suction cup, EPDM, 50 Shore, G1/4" female, 16 mm hex	2321487
F	VG.U22E.50.G14M.E17	VG.U22 suction cup, EPDM, 50 Shore, G1/4" male, 17 mm hex	2321488
A	VG.U22H.60.G18F.E12	VG.U22 suction cup, HNBR, 60 Shore, G1/8" female, 12 mm hex	2321489
B	VG.U22H.60.G18M.E12	VG.U22 suction cup, HNBR, 60 Shore, G1/8" male, 12 mm hex	2321491
C	VG.U22H.60.G18F.E16	VG.U22 suction cup, HNBR, 60 Shore, G1/8" female, 16 mm hex	2321492
D	VG.U22H.60.G18M.E16	VG.U22 suction cup, HNBR, 60 Shore, G1/8" male, 16 mm hex	2321493
E	VG.U22H.60.G14F.E16	VG.U22 suction cup, HNBR, 60 Shore, G1/4" female, 16 mm hex	2321494
F	VG.U22H.60.G14M.E17	VG.U22 suction cup, HNBR, 60 Shore, G1/4" male, 17 mm hex	2321495

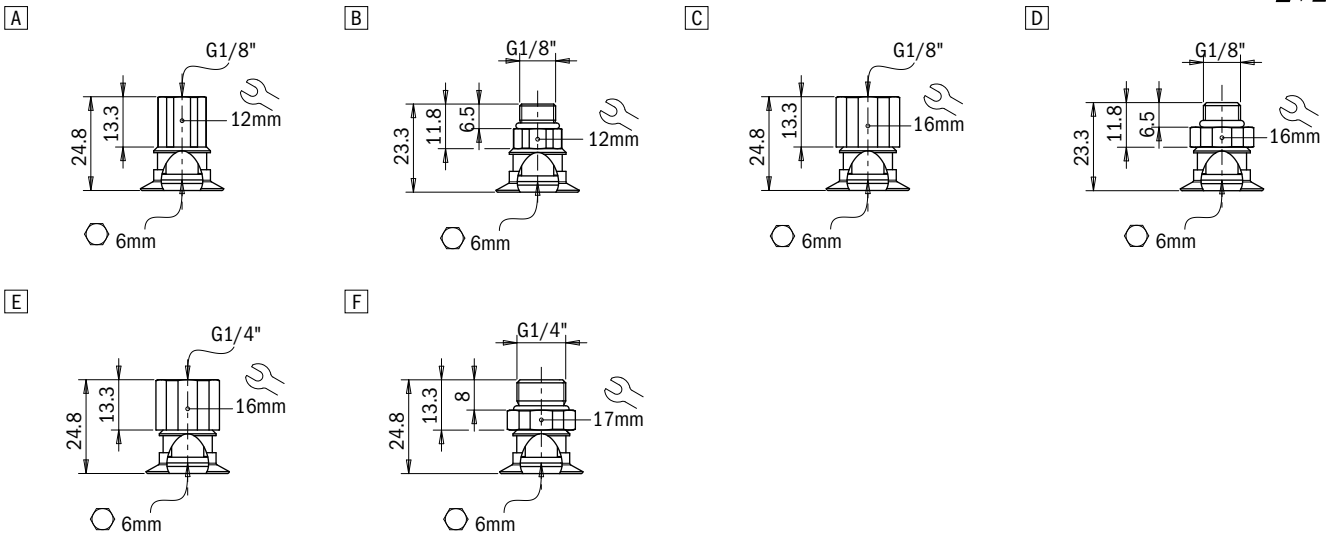

Ordering information

Drawing	Alphanumeric code	Suction cups	Order code
A	VG.U22E.50	VG.U22 suction cup, EPDM, 50 Shore	2321483
A	VG.U22H.60	VG.U22 suction cup, HNBR, 60 Shore	2321490

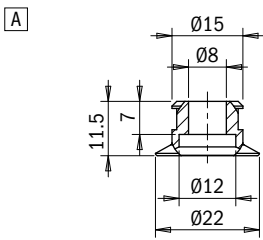

Ordering information

Drawing	Alphanumeric code	Fittings	Order code
A	FT.G18F.E12	G1/8" female fitting, 12 mm hex	2321422
B	FT.G18M.E12	G1/8" male fitting, 12 mm hex	2321424
C	FT.G18F.E16	G1/8" female fitting, 16 mm hex	2321426
D	FT.G18M.E16	G1/8" male fitting, 16 mm hex	2321428
E	FT.G14F.E16	G1/4" female fitting, 16 mm hex	2321430
F	FT.G14M.E17	G1/4" male fitting, 17 mm hex	2321432

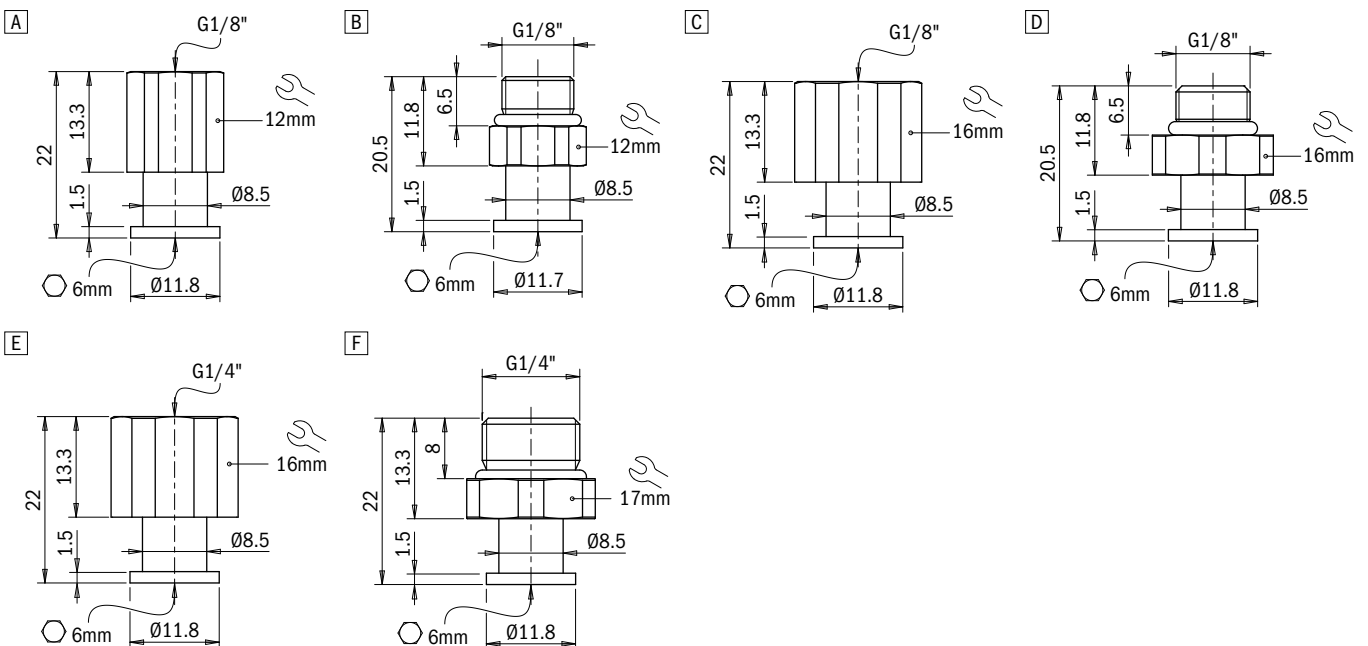

Suction cups / EPDM-HNBR

VG.U33 flat EPDM-HNBR suction cups

- Suitable for handling plastic parts
- Suitable for objects with flat or slightly curved surfaces
- The HNBR version enables to work at high temperatures, whereas silicone or other mixtures may release traces of material. Ideal for applications where contamination of the material must be avoided (PWIS)
- The HNBR compound is robust and wear resistant, suitable for the removal of hot plastic parts from the relevant moulds

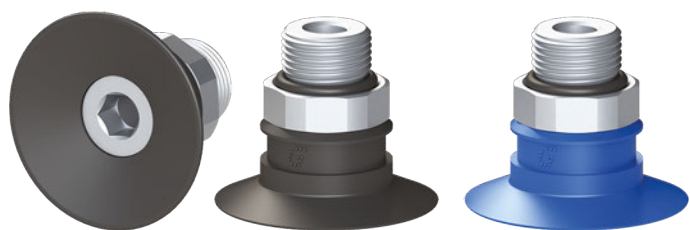

Application example



Technical data

Material	Lifting force [N] perpendicular to the surface, at various vacuum levels			Lifting force [N] parallel to the surface, at various vacuum levels			Volume [cm ³]	Min curve radius [mm]	Max vertical movement [mm]	Suction cup weight [g]
	-20 kPa	-60 kPa	-90 kPa	-20 kPa	-60 kPa	-90 kPa				
EPDM 50	11	29	38	8.5	15	12.5	2	20	3.5	2.4
HNBR 60	11	29	38	8.5	15	12.5	2	20	3.5	2.4

Technical features

Material	Color	Hardness	Temperature range
EPDM	Black	50 Shore	-40 - +212 °F
HNBR	Blue	60 Shore	-13 - +302 °F

Identification codes

Drawing	Alphanumeric code	Suction cups with fitting	Order code
A	VG.U33E.50.G18F.E12	VG.U33 suction cup, EPDM, 50 Shore, G1/8" female, 12 mm hex	2321496
B	VG.U33E.50.G18M.E12	VG.U33 suction cup, EPDM, 50 Shore, G1/8" male, 12 mm hex	2321498
C	VG.U33E.50.G18F.E16	VG.U33 suction cup, EPDM, 50 Shore, G1/8" female, 16 mm hex	2321499
D	VG.U33E.50.G18M.E16	VG.U33 suction cup, EPDM, 50 Shore, G1/8" male, 16 mm hex	2321500
E	VG.U33E.50.G14F.E16	VG.U33 suction cup, EPDM, 50 Shore, G1/4" female, 16 mm hex	2321501
F	VG.U33E.50.G14M.E17	VG.U33 suction cup, EPDM, 50 Shore, G1/4" male, 17 mm hex	2321502
A	VG.U33H.60.G18F.E12	VG.U33 suction cup, HNBR, 60 Shore, G1/8" female, 12 mm hex	2321503
B	VG.U33H.60.G18M.E12	VG.U33 suction cup, HNBR, 60 Shore, G1/8" male, 12 mm hex	2321505
C	VG.U33H.60.G18F.E16	VG.U33 suction cup, HNBR, 60 Shore, G1/8" female, 16 mm hex	2321506
D	VG.U33H.60.G18M.E16	VG.U33 suction cup, HNBR, 60 Shore, G1/8" male, 16 mm hex	2321507
E	VG.U33H.60.G14F.E16	VG.U33 suction cup, HNBR, 60 Shore, G1/4" female, 16 mm hex	2321508
F	VG.U33H.60.G14M.E17	VG.U33 suction cup, HNBR, 60 Shore, G1/4" male, 17 mm hex	2321509

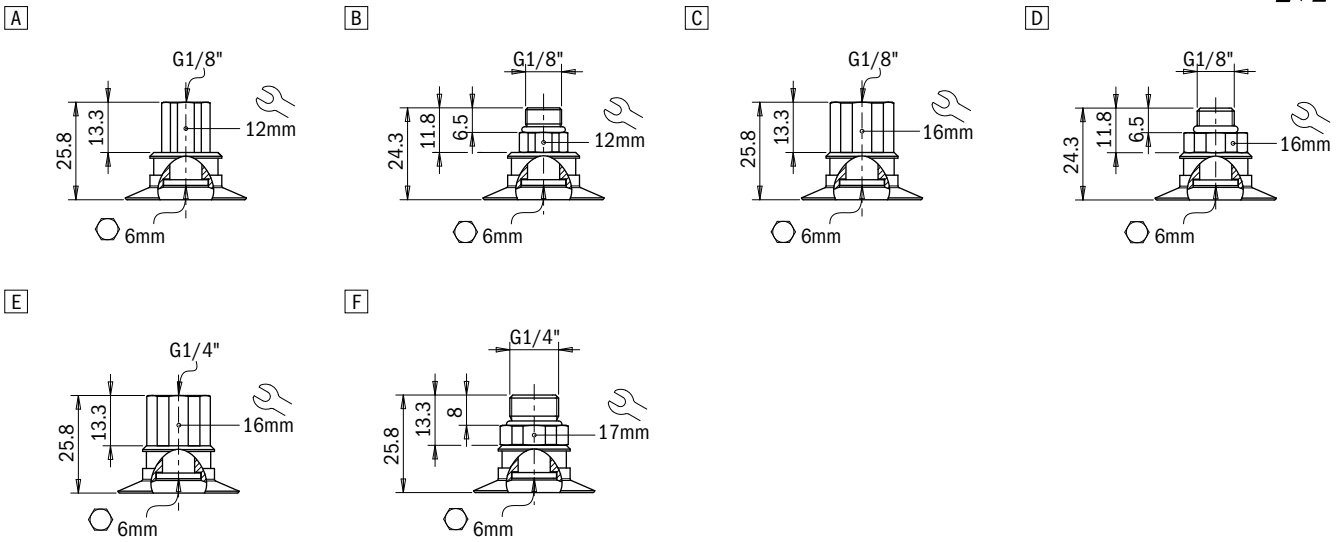

Identification codes

Drawing	Alphanumeric code	Suction cups	Order code
A	VG.U33E.50	VG.U33 suction cup, EPDM, 50 Shore	2321497
A	VG.U33H.60	VG.U33 suction cup, HNBR, 60 Shore	2321504

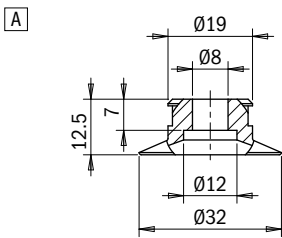

Identification codes

Drawing	Alphanumeric code	Fittings	Order code
A	FT.G18F.E12	G1/8" female fitting, 12 mm hex	2321422
B	FT.G18M.E12	G1/8" male fitting, 12 mm hex	2321424
C	FT.G18F.E16	G1/8" female fitting, 16 mm hex	2321426
D	FT.G18M.E16	G1/8" male fitting, 16 mm hex	2321428
E	FT.G14F.E16	G1/4" female fitting, 16 mm hex	2321430
F	FT.G14M.E17	G1/4" male fitting, 17 mm hex	2321432

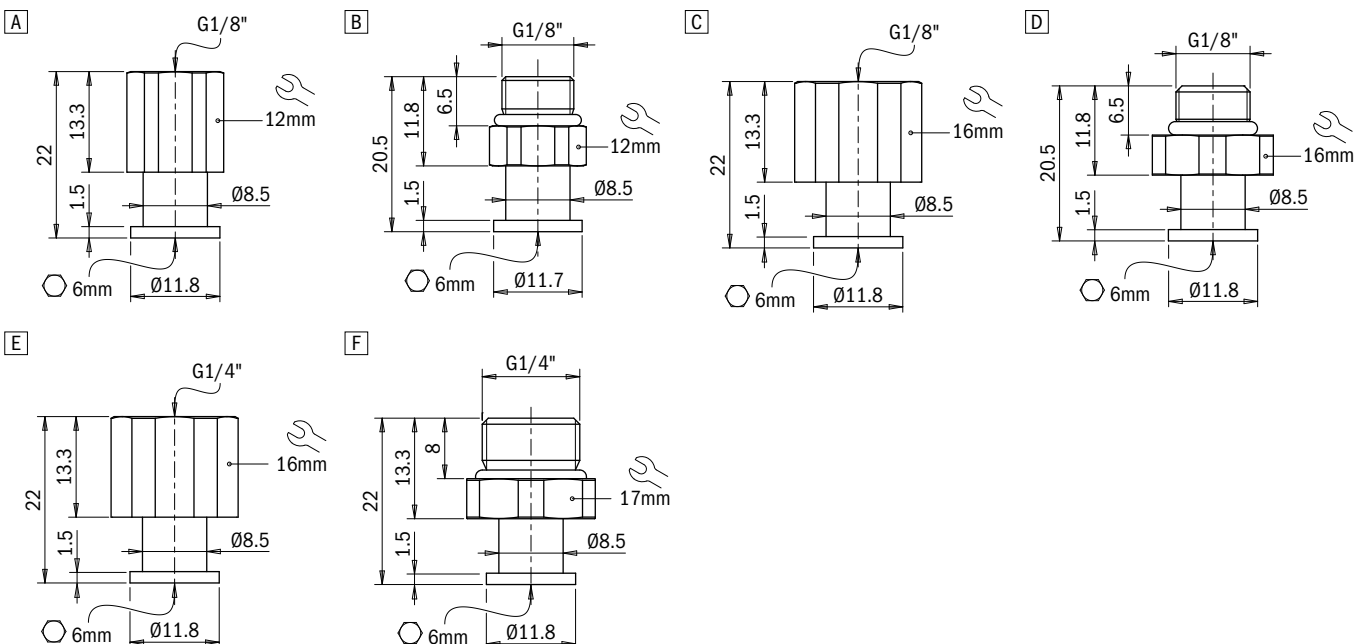

Suction cups / EPDM-HNBR

VG.U42 flat EPDM-HNBR suction cups

- Suitable for handling plastic parts
- Suitable for objects with flat or slightly curved surfaces
- The HNBR version enables to work at high temperatures, whereas silicone or other mixtures may release traces of material. Ideal for applications where contamination of the material must be avoided (PWIS)
- The HNBR compound is robust and wear resistant, suitable for the removal of hot plastic parts from the relevant moulds

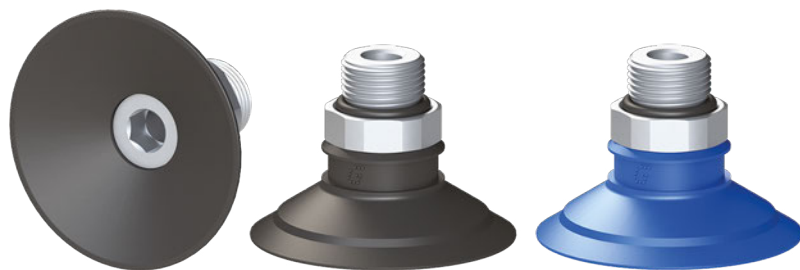

Application example

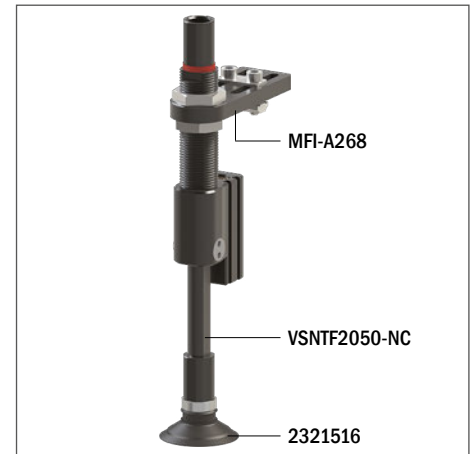

Technical data

Material	Lifting force [N] perpendicular to the surface, at various vacuum levels			Lifting force [N] parallel to the surface, at various vacuum levels			Volume [cm ³]	Min curve radius [mm]	Max vert. movement [mm]	Suction cup weight [g]
	-20 kPa	-60 kPa	-90 kPa	-20 kPa	-60 kPa	-90 kPa				
EPDM 50	21	48.5	58	14	28	36	5.5	30	4.5	4.4
HNBR 60	21	48.5	58	14	28	36	5.5	30	4.5	4.4

Technical features

Material	Color	Hardness	Temperature range
EPDM	Black	50 Shore	-40 - +212 °F
HNBR	Blue	60 Shore	-13 - +302 °F

Ordering information

Drawing	Alphanumeric code	Suction cups with fitting	Order code
A	VG.U42E.50.G18F.E12	VG.U42 suction cup, EPDM, 50 Shore, G1/8" female, 12 mm hex	2321510
B	VG.U42E.50.G18M.E12	VG.U42 suction cup, EPDM, 50 Shore, G1/8" male, 12 mm hex	2321512
C	VG.U42E.50.G18F.E16	VG.U42 suction cup, EPDM, 50 Shore, G1/8" female, 16 mm hex	2321513
D	VG.U42E.50.G18M.E16	VG.U42 suction cup, EPDM, 50 Shore, G1/8" male, 16 mm hex	2321514
E	VG.U42E.50.G14F.E16	VG.U42 suction cup, EPDM, 50 Shore, G1/4" female, 16 mm hex	2321515
F	VG.U42E.50.G14M.E17	VG.U42 suction cup, EPDM, 50 Shore, G1/4" male, 17 mm hex	2321516
A	VG.U42H.60.G18F.E12	VG.U42 suction cup, HNBR, 60 Shore, G1/8" female, 12 mm hex	2321517
B	VG.U42H.60.G18M.E12	VG.U42 suction cup, HNBR, 60 Shore, G1/8" male, 12 mm hex	2321519
C	VG.U42H.60.G18F.E16	VG.U42 suction cup, HNBR, 60 Shore, G1/8" female, 16 mm hex	2321520
D	VG.U42H.60.G18M.E16	VG.U42 suction cup, HNBR, 60 Shore, G1/8" male, 16 mm hex	2321521
E	VG.U42H.60.G14F.E16	VG.U42 suction cup, HNBR, 60 Shore, G1/4" female, 16 mm hex	2321522
F	VG.U42H.60.G14M.E17	VG.U42 suction cup, HNBR, 60 Shore, G1/4" male, 17 mm hex	2321523

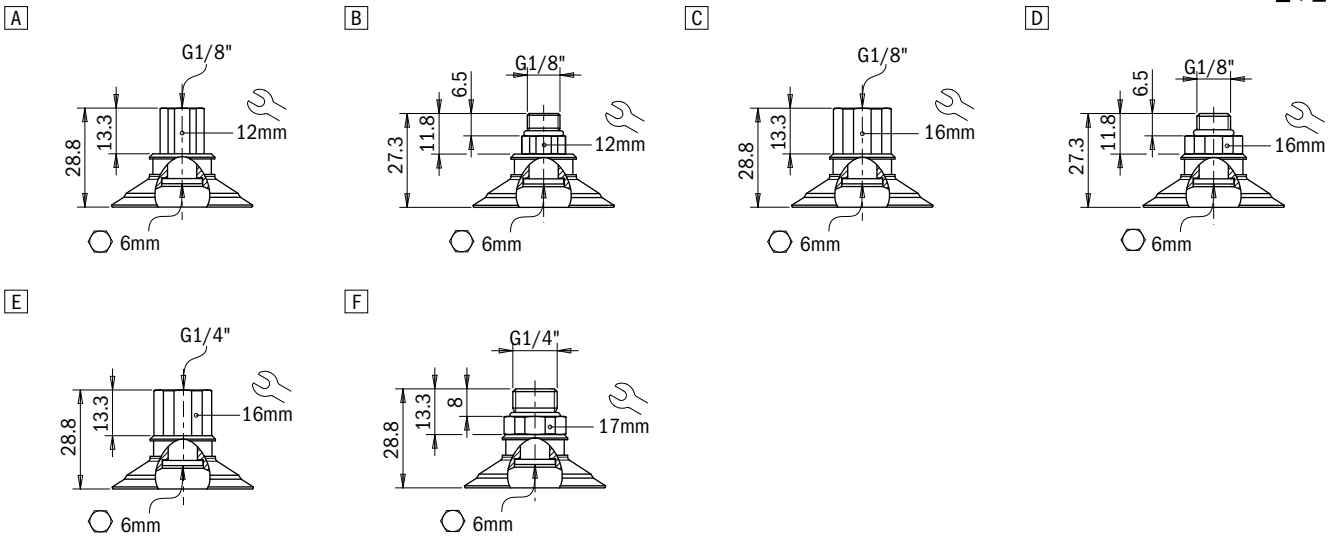

Ordering information

Drawing	Alphanumeric code	Suction cups	Order code
A	VG.U42E.50	VG.U42 suction cup, EPDM, 50 Shore	2321511
A	VG.U42H.60	VG.U42 suction cup, HNBR, 60 Shore	2321518

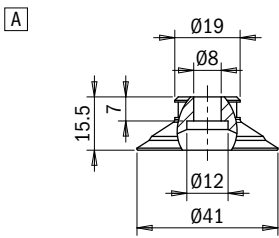

Ordering information

Drawing	Alphanumeric code	Fittings	Order code
A	FT.G18F.E12	G1/8" female fitting, 12 mm hex	2321422
B	FT.G18M.E12	G1/8" male fitting, 12 mm hex	2321424
C	FT.G18F.E16	G1/8" female fitting, 16 mm hex	2321426
D	FT.G18M.E16	G1/8" male fitting, 16 mm hex	2321428
E	FT.G14F.E16	G1/4" female fitting, 16 mm hex	2321430
F	FT.G14M.E17	G1/4" male fitting, 17 mm hex	2321432

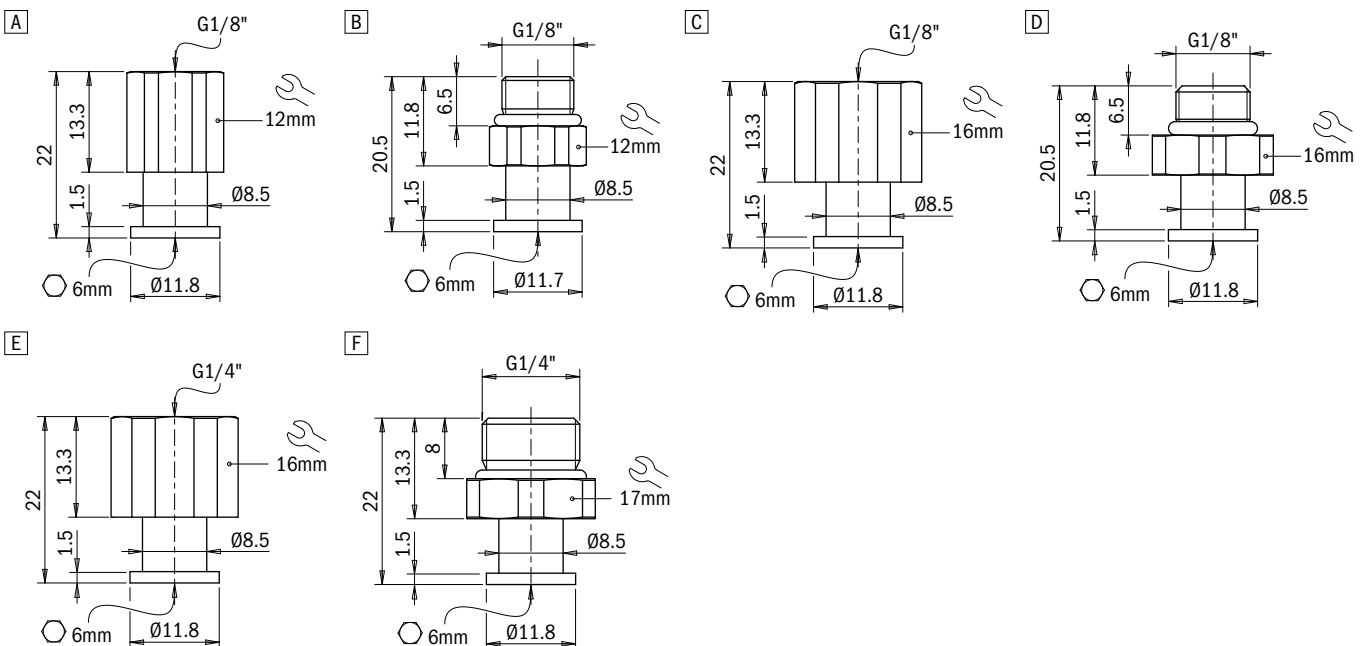

Suction cups / EPDM-HNBR

VG.U53 flat EPDM-HNBR suction cups

- Suitable for handling plastic parts
- Suitable for objects with flat or slightly curved surfaces
- The HNBR version enables to work at high temperatures, whereas silicone or other mixtures may release traces of material. Ideal for applications where contamination of the material must be avoided (PWIS)
- The HNBR compound is robust and wear resistant, suitable for the removal of hot plastic parts from the relevant moulds

Application example

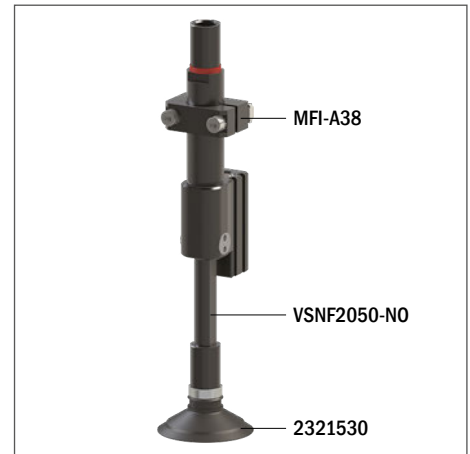

Technical data

Material	Lifting force [N] perpendicular to the surface, at various vacuum levels			Lifting force [N] parallel to the surface, at various vacuum levels			Volume [cm ³]	Min curve radius [mm]	Max vert. movement [mm]	Suction cup weight [g]
	-20 kPa	-60 kPa	-90 kPa	-20 kPa	-60 kPa	-90 kPa				
EPDM 50	37	75	96	20	35	46	12	35	6	7.9
HNBR 60	37	75	96	20	35	46	12	35	6	7.9

Technical features

Material	Color	Hardness	Temperature range
EPDM	Black	50 Shore	-40 - +212 °F
HNBR	Blue	60 Shore	-13 - +302 °F

Ordering information

Drawing	Alphanumeric code	Suction cups with fitting	Order code
A	VG.U53E.50.G18F.E12	VG.U53 suction cup, EPDM, 50 Shore, G1/8" female, 12 mm hex	2321524
B	VG.U53E.50.G18M.E12	VG.U53 suction cup, EPDM, 50 Shore, G1/8" male, 12 mm hex	2321526
C	VG.U53E.50.G18F.E16	VG.U53 suction cup, EPDM, 50 Shore, G1/8" female, 16 mm hex	2321527
D	VG.U53E.50.G18M.E16	VG.U53 suction cup, EPDM, 50 Shore, G1/8" male, 16 mm hex	2321528
E	VG.U53E.50.G14F.E16	VG.U53 suction cup, EPDM, 50 Shore, G1/4" female, 16 mm hex	2321529
F	VG.U53E.50.G14M.E17	VG.U53 suction cup, EPDM, 50 Shore, G1/4" male, 17 mm hex	2321530
A	VG.U53H.60.G18F.E12	VG.U53 suction cup, HNBR, 60 Shore, G1/8" female, 12 mm hex	2321531
B	VG.U53H.60.G18M.E12	VG.U53 suction cup, HNBR, 60 Shore, G1/8" male, 12 mm hex	2321533
C	VG.U53H.60.G18F.E16	VG.U53 suction cup, HNBR, 60 Shore, G1/8" female, 16 mm hex	2321534
D	VG.U53H.60.G18M.E16	VG.U53 suction cup, HNBR, 60 Shore, G1/8" male, 16 mm hex	2321535
E	VG.U53H.60.G14F.E16	VG.U53 suction cup, HNBR, 60 Shore, G1/4" female, 16 mm hex	2321536
F	VG.U53H.60.G14M.E17	VG.U53 suction cup, HNBR, 60 Shore, G1/4" male, 17 mm hex	2321537

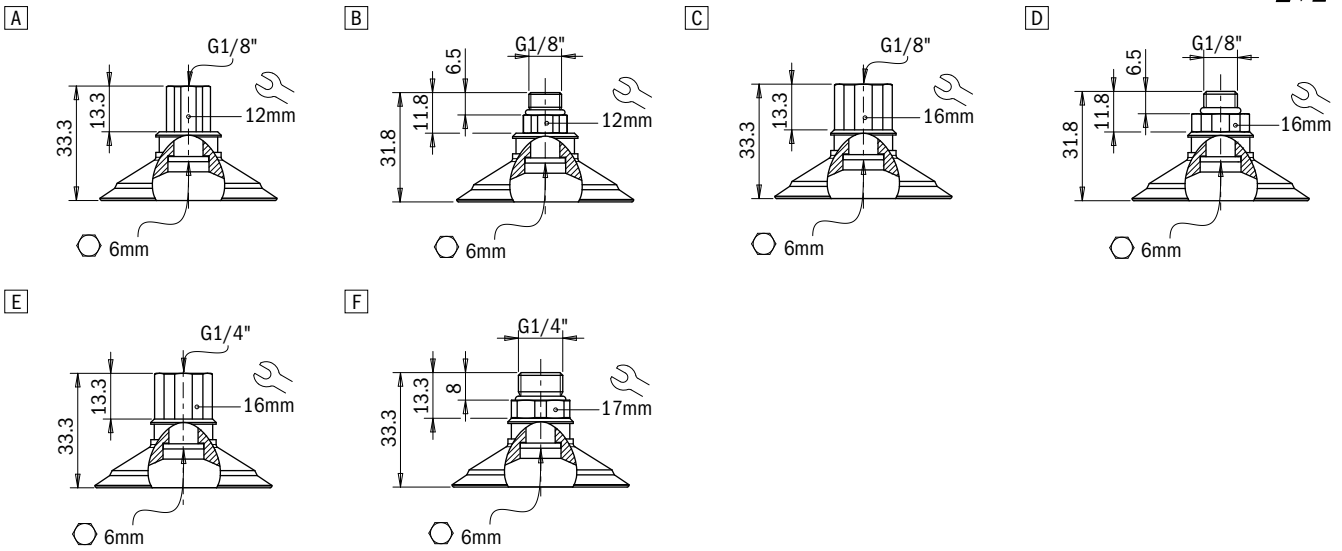

Ordering information

Drawing	Alphanumeric code	Suction cups	Order code
A	VG.U53E.50	VG.U53 suction cup, EPDM, 50 Shore	2321525
A	VG.U53H.60	VG.U53 suction cup, HNBR, 60 Shore	2321532

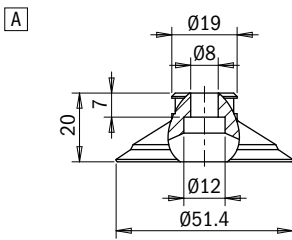

Ordering information

Drawing	Alphanumeric code	Fittings	Order code
A	FT.G18F.E12	G1/8" female fitting, 12 mm hex	2321422
B	FT.G18M.E12	G1/8" male fitting, 12 mm hex	2321424
C	FT.G18F.E16	G1/8" female fitting, 16 mm hex	2321426
D	FT.G18M.E16	G1/8" male fitting, 16 mm hex	2321428
E	FT.G14F.E16	G1/4" female fitting, 16 mm hex	2321430
F	FT.G14M.E17	G1/4" male fitting, 17 mm hex	2321432

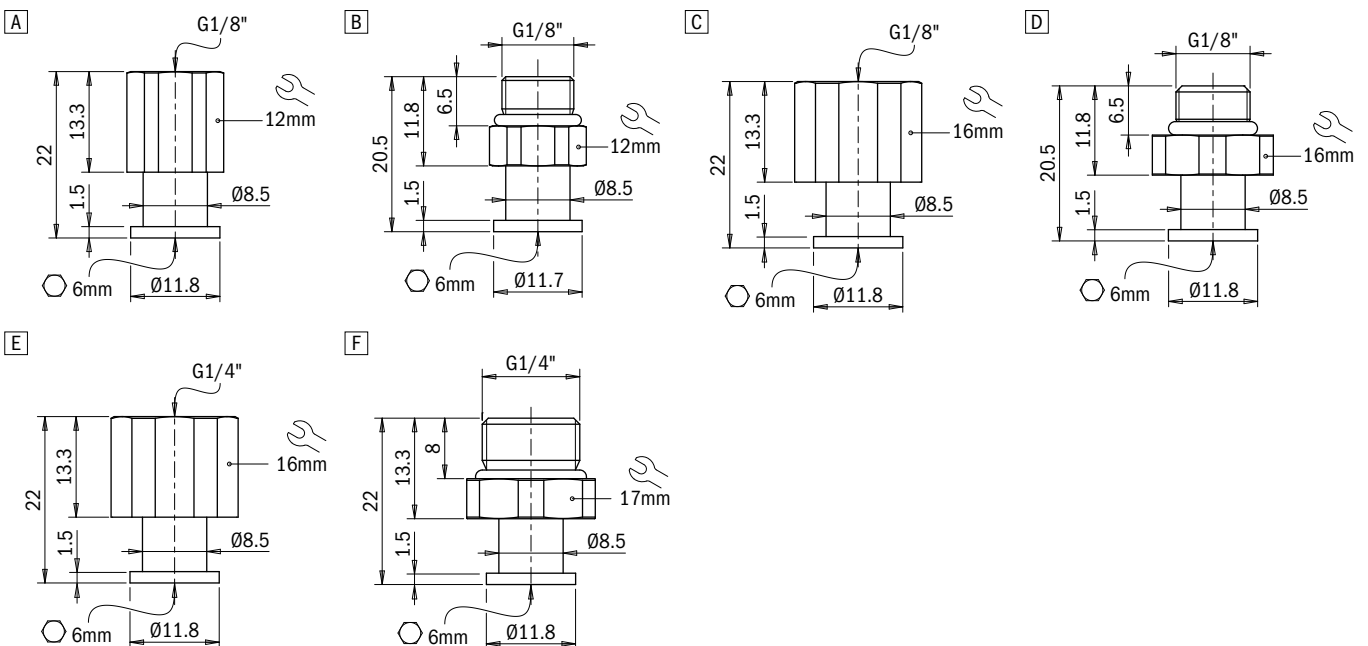

Suction cups / Silicone

VG.B6S bellows suction cups in silicone

- Silicone compound
- Suitable for high working temperatures
- Suitable for objects with flat or slightly curved surfaces
- They enable to compensate for differences in height



Application example

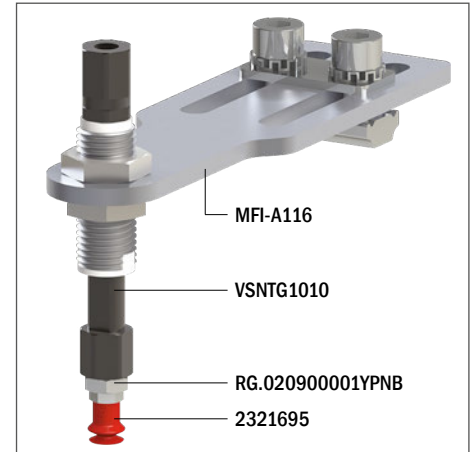

Technical data

Material	Lifting force [N] perpendicular to the surface, at various vacuum levels			Lifting force [N] parallel to the surface, at various vacuum levels			Volume [cm ³]	Min curve radius [mm]	Max vertical movement [mm]	Suction cup weight [g]
	-20 kPa	-60 kPa	-90 kPa	-20 kPa	-60 kPa	-90 kPa				
SIL 50	0.25	0.78	1.1	–	–	–	0.05	1.5	1.5	0.1

Technical features

Material	Color	Hardness	Temperature range
Silicone, SIL	Red	50 Shore	-94 - +392 °F

Identification codes

Drawing	Alphanumeric code	Suction cups with fitting	Order code
A	VG.B6S.50.M3M.E5	VG.B6 suction cup, silicone, 50 Shore, M3 Male, 5 mm hex	2321695
B	VG.B6S.50.M5M.E8	VG.B6 suction cup, silicone, 50 Shore, M5 Male, 8 mm hex	2321095

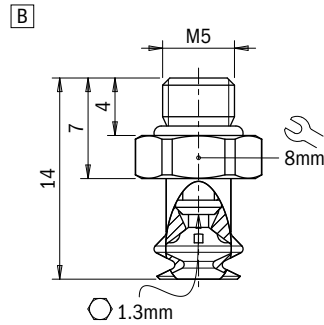
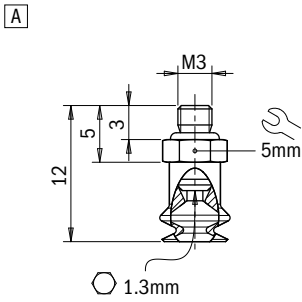

Identification codes

Drawing	Alphanumeric code	Suction cups	Order code
A	VG.B6S.50	VG.B6 suction cup, silicone, 50 Shore	2321696

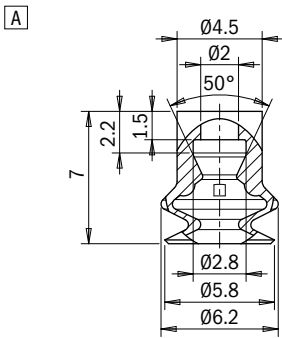

Identification codes

Drawing	Alphanumeric code	Fittings	Order code
A	FT.M3M.E5	M3 male fitting, hex, 5 mm	2321402
B	FT.M5M.E8.06	M5 male fitting, hex, 8 mm	2321005

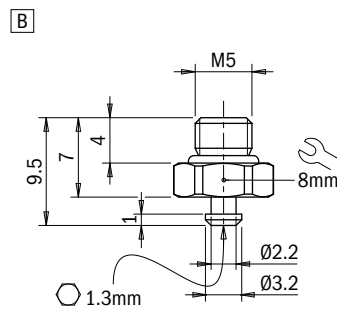
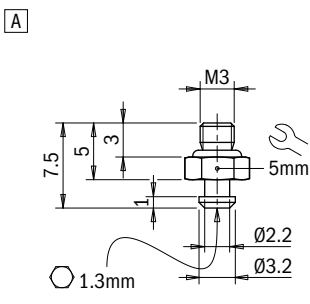

Suction cups / Silicone

VG.B9S bellows suction cups in silicone

- Silicone compound
- Suitable for high working temperatures
- Suitable for objects with flat or slightly curved surfaces
- They enable to compensate for differences in height



Application example

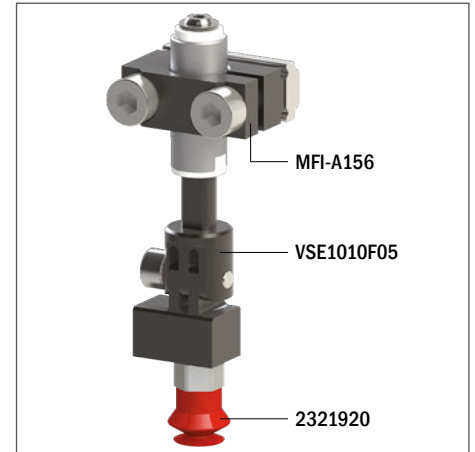

Technical data

Material	Lifting force [N] perpendicular to the surface, at various vacuum levels			Lifting force [N] parallel to the surface, at various vacuum levels			Volume [cm ³]	Min curve radius [mm]	Max vertical movement [mm]	Suction cup weight [g]
	-20 kPa	-60 kPa	-90 kPa	-20 kPa	-60 kPa	-90 kPa				
SIL 50	0.82	1.5	2.3	–	–	–	0.15	1.9	3.5	0.3

Technical features

Material	Color	Hardness	Temperature range
Silicone, SIL	Red	50 Shore	-94 - +392 °F

Identification codes			
Drawing	Alphanumeric code	Suction cups with fitting	Order code
A	VG.B9S.50.M5M.E8	VG.B9 suction cup, silicone, 50 Shore, M5 male, 8 mm hex	2321920



Click for Pricing & Add to Cart

A

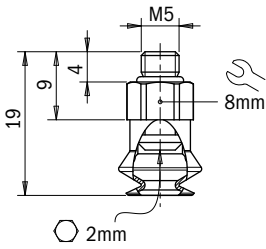

Identification codes			
Drawing	Alphanumeric code	Suction cups	Order code
A	VG.B9S.50	VG.B9 suction cup, silicone, 50 Shore	2321921

A

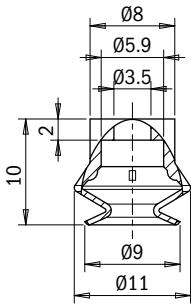

Identification codes			
Drawing	Alphanumeric code	Fittings	Order code
A	FT.M5M.E8.05	M5 male fitting, 8 mm hex	2321405

A

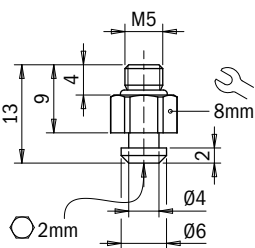

Suction cups / Silicone

VG.B11S bellows suction cups in silicone

- Silicone compound
- Suitable for high working temperatures
- Suitable for objects with flat or slightly curved surfaces
- They enable to compensate for differences in height



Application example

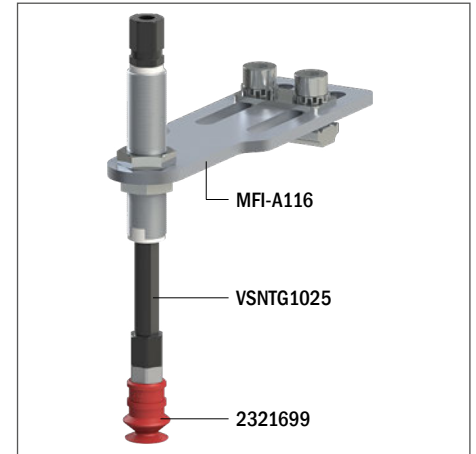

Technical data

Material	Lifting force [N] perpendicular to the surface, at various vacuum levels			Lifting force [N] parallel to the surface, at various vacuum levels			Volume [cm ³]	Min curve radius [mm]	Max vertical movement [mm]	Suction cup weight [g]
	-20 kPa	-60 kPa	-90 kPa	-20 kPa	-60 kPa	-90 kPa				
SIL 50	1.3	3.4	4.6	1.7	2.42	2.81	0.48	4	4.5	0.7

Technical features

Material	Color	Hardness	Temperature range
Silicone, SIL	Red	50 Shore	-94 - +392 °F

Identification codes

Drawing	Alphanumeric code	Suction cups with fitting	Order code
A	VG.B11S.50.M5F.E8	VG.B11 suction cup, silicone, 50 Shore, M5 female, 8 mm hex	2321697
B	VG.B11S.50.M5M.E8	VG.B11 suction cup, silicone, 50 Shore, M5 male, 8 mm hex	2321699
C	VG.B11S.50.G18F.E13	VG.B11 suction cup, silicone, 50 Shore, G1/8" female, 13 mm hex	2321700
D	VG.B11S.50.G18M.E13	VG.B11 suction cup, silicone, 50 Shore, G1/8" male, 13 mm hex	2321701

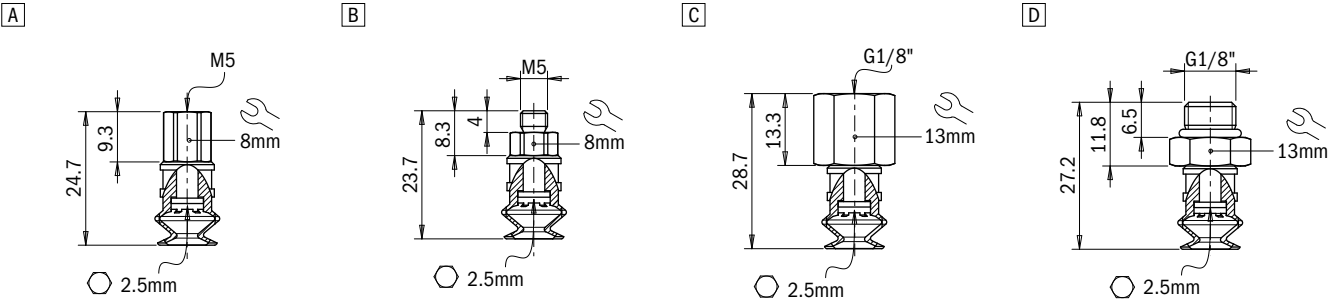

Identification codes

Drawing	Alphanumeric code	Suction cups	Order code
A	VG.B11S.50	VG.B11 suction cup, silicone, 50 Shore	2321698

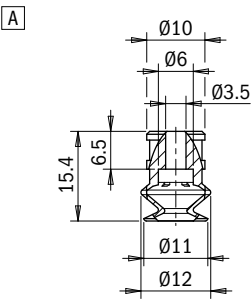

Identification codes

Drawing	Alphanumeric code	Fittings	Order code
A	FT.M5F.E8	M5 female fitting, 8 mm hex	2321408
B	FT.M5M.E8	M5 male fitting, 8 mm hex	2321410
C	FT.G18F.E13	G1/8" female fitting, 13 mm hex	2321412
D	FT.G18M.E13	G1/8" male fitting, 13 mm hex	2321414

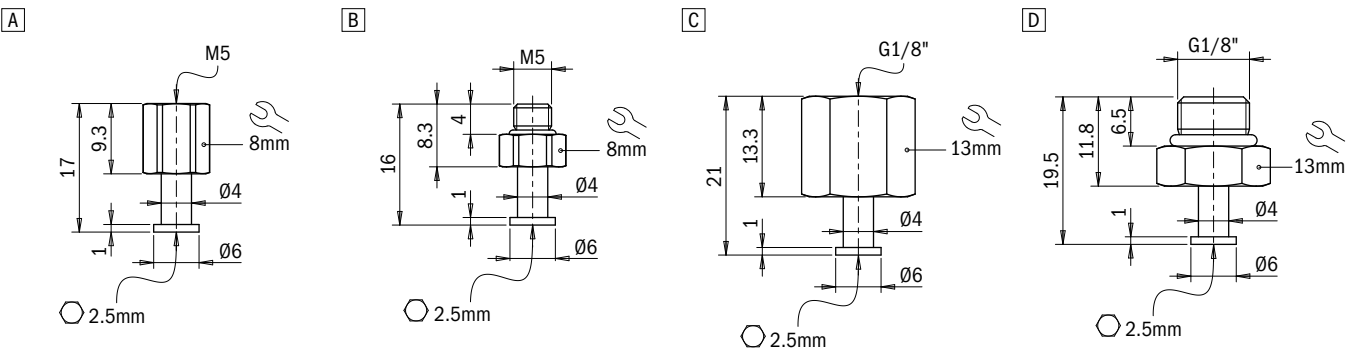

Suction cups / Silicone

VG.B16S bellows suction cups in silicone

- Silicone compound
- Suitable for high working temperatures
- Suitable for objects with flat or slightly curved surfaces
- They enable to compensate for differences in height

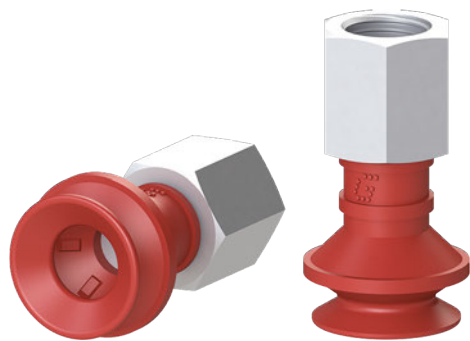

Application example

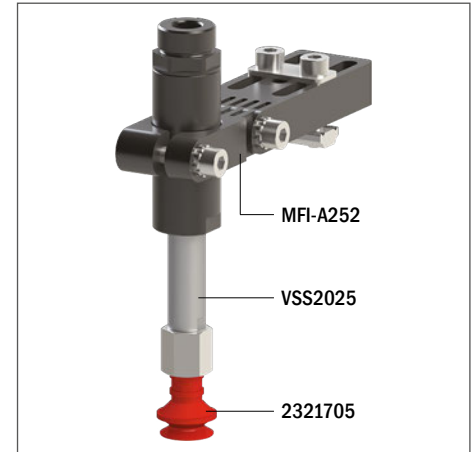

Technical data

Material	Lifting force [N] perpendicular to the surface, at various vacuum levels			Lifting force [N] parallel to the surface, at various vacuum levels			Volume [cm ³]	Min curve radius [mm]	Max vertical movement [mm]	Suction cup weight [g]
	-20 kPa	-60 kPa	-90 kPa	-20 kPa	-60 kPa	-90 kPa				
SIL 50	3	5.8	8.5	1.71	3.1	3.9	1.1	5	6.5	2.1

Technical features

Material	Color	Hardness	Temperature range
Silicone, SIL	Red	50 Shore	-94 - +392 °F

Identification codes

Drawing	Alphanumeric code	Suction cups with fitting	Order code
A	VG.B16S.50.M5F.E8	VG.B16 suction cup, silicone, 50 Shore, M5 female, 8 mm hex	2321702
B	VG.B16S.50.M5M.E8	VG.B16 suction cup, silicone, 50 Shore, M5 male, 8 mm hex	2321704
C	VG.B16S.50.G18F.E13	VG.B16 suction cup, silicone, 50 Shore, G1/8" female, 13 mm hex	2321705
D	VG.B16S.50.G18M.E13	VG.B16 suction cup, silicone, 50 Shore, G1/8" male, 13 mm hex	2321706

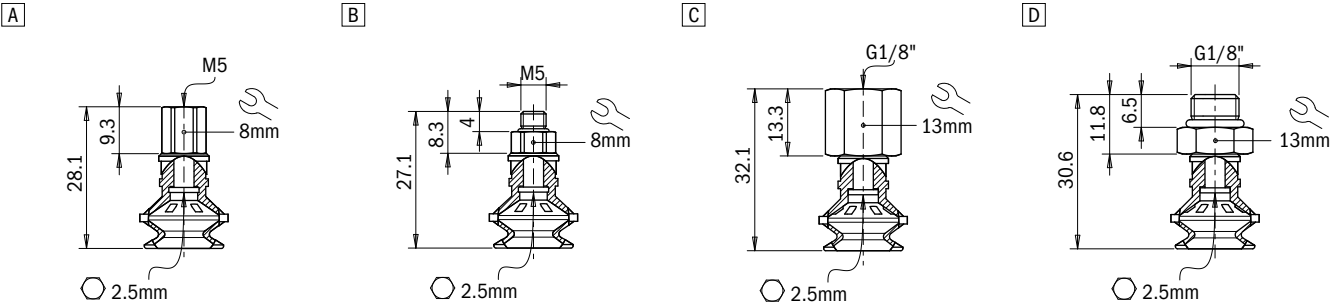

Identification codes

Drawing	Alphanumeric code	Suction cups	Order code
A	VG.B16S.50	VG.B16 suction cup, silicone, 50 Shore	2321703

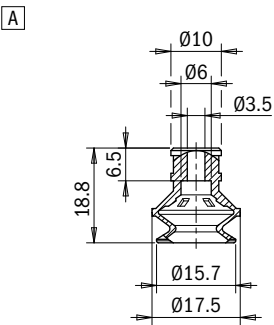

Identification codes

Drawing	Alphanumeric code	Fittings	Order code
A	FT.M5F.E8	M5 female fitting, 8 mm hex	2321408
B	FT.M5M.E8	M5 male fitting, 8 mm hex	2321410
C	FT.G18F.E13	G1/8" female fitting, 13 mm hex	2321412
D	FT.G18M.E13	G1/8" male fitting, 13 mm hex	2321414

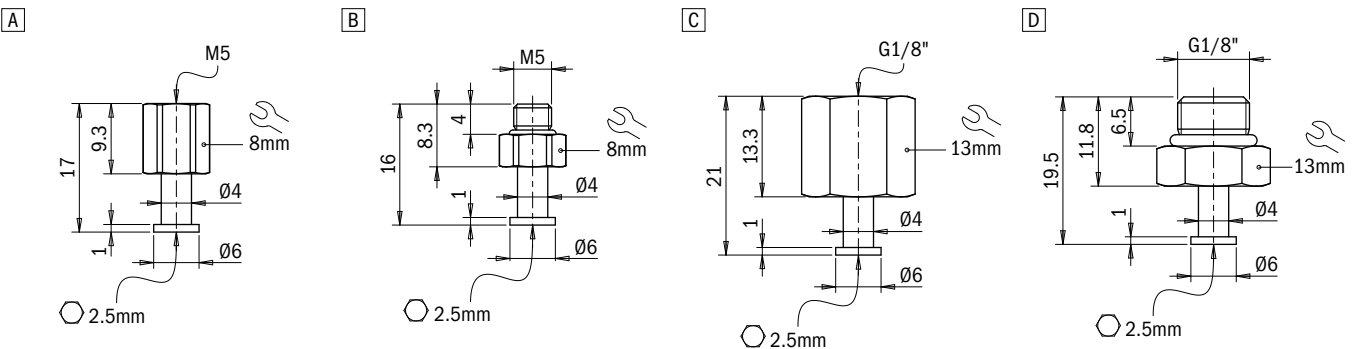

Suction cups / Silicone

VG.B22S bellows suction cups in silicone

- Silicone compound
- Suitable for high working temperatures
- Suitable for objects with flat or slightly curved surfaces
- They enable to compensate for differences in height

Application example

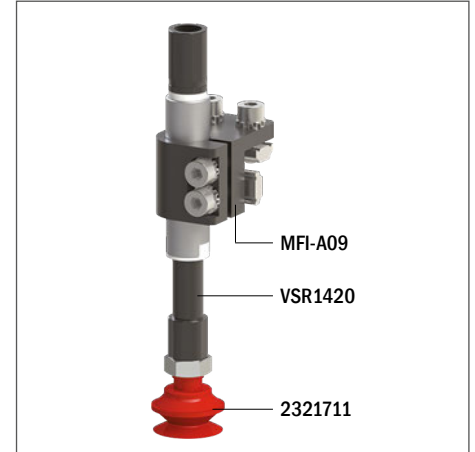

Technical data

Material	Lifting force [N] perpendicular to the surface, at various vacuum levels			Lifting force [N] parallel to the surface, at various vacuum levels			Volume [cm ³]	Min curve radius [mm]	Max vertical movement [mm]	Suction cup weight [g]
	-20 kPa	-60 kPa	-90 kPa	-20 kPa	-60 kPa	-90 kPa				
SIL 50	5.5	13	14	2.92	5.5	8.3	2.7	10	10	1.8

Technical features

Material	Color	Hardness	Temperature range
Silicone, SIL	Red	50 Shore	-94 - +392 °F

Identification codes

Drawing	Alphanumeric code	Suction cups with fitting	Order code
A	VG.B22S.50.M5F.E8	VG.B22 suction cup, silicone, 50 Shore, M5 female, 8 mm hex	2321707
B	VG.B22S.50.M5M.E8	VG.B22 suction cup, silicone, 50 Shore, M5 male, 8 mm hex	2321709
C	VG.B22S.50.G18F.E13	VG.B22 suction cup, silicone, 50 Shore, G1/8" female, 13 mm hex	2321710
D	VG.B22S.50.G18M.E13	VG.B22 suction cup, silicone, 50 Shore, G1/8" male, 13 mm hex	2321711

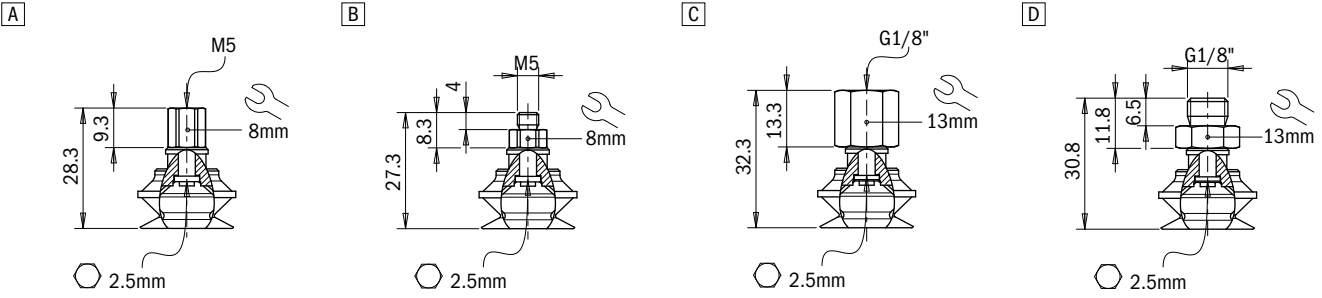

Identification codes

Drawing	Alphanumeric code	Suction cups	Order code
A	VG.B22S.50	VG.B22 suction cup, silicone, 50 Shore	2321708

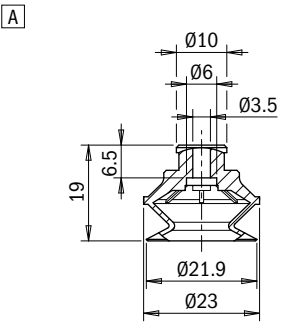

Identification codes

Drawing	Alphanumeric code	Fittings	Order code
A	FT.M5F.E8	M5 female fitting, 8 mm hex	2321408
B	FT.M5M.E8	M5 male fitting, 8 mm hex	2321410
C	FT.G18F.E13	G1/8" female fitting, 13 mm hex	2321412
D	FT.G18M.E13	G1/8" male fitting, 13 mm hex	2321414

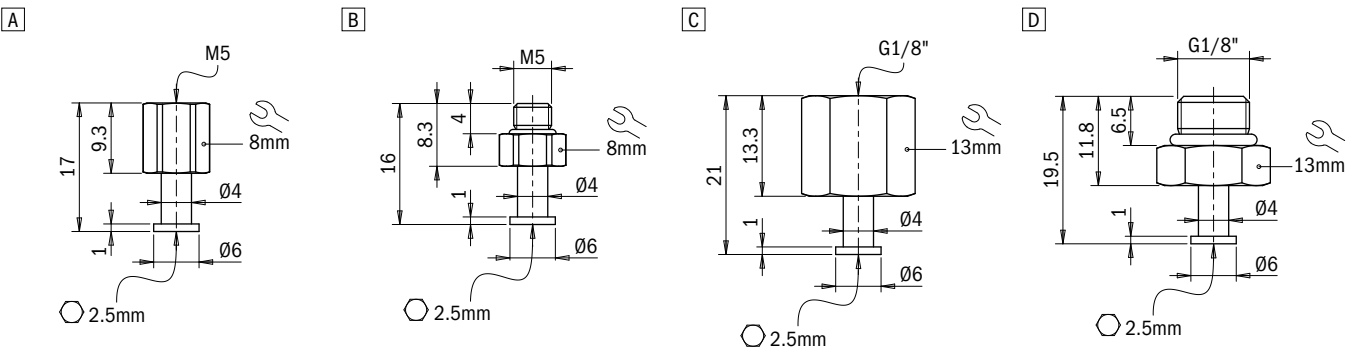

Suction cups / Silicone

VG.B33S bellows suction cups in silicone

- Silicone compound
- Suitable for high working temperatures
- Suitable for objects with flat or slightly curved surfaces
- They enable to compensate for differences in height

Application example

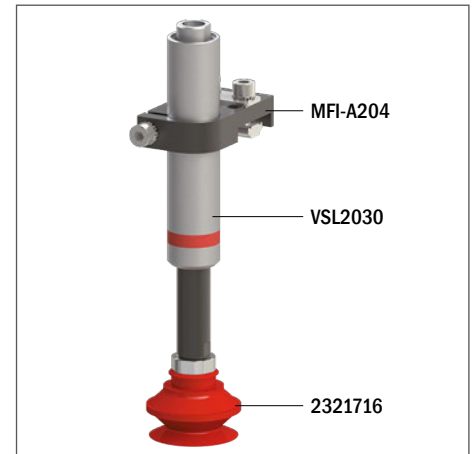

Technical data

Material	Lifting force [N] perpendicular to the surface, at various vacuum levels			Lifting force [N] parallel to the surface, at various vacuum levels			Volume [cm ³]	Min curve radius [mm]	Max vertical movement [mm]	Suction cup weight [g]
	-20 kPa	-60 kPa	-90 kPa	-20 kPa	-60 kPa	-90 kPa				
SIL 50	12	23	26	9.5	16.6	22.5	10	15	15	5.8

Technical features

Material	Color	Hardness	Temperature range
Silicone, SIL	Red	50 Shore	-94 - +392 °F

Identification codes

Drawing	Alphanumeric code	Suction cups with fitting	Order code
A	VG.B33S.50.G18F.E12	VG.B33 suction cup, silicone, 50 Shore, G1/8" female, 12 mm hex	2321712
B	VG.B33S.50.G18M.E12	VG.B33 suction cup, silicone, 50 Shore, G1/8" male, 12 mm hex	2321714
C	VG.B33S.50.G18F.E16	VG.B33 suction cup, silicone, 50 Shore, G1/8" female, 16 mm hex	2321715
D	VG.B33S.50.G18M.E16	VG.B33 suction cup, silicone, 50 Shore, G1/8" male, 16 mm hex	2321716
E	VG.B33S.50.G14F.E16	VG.B33 suction cup, silicone, 50 Shore, G1/4" female, 16 mm hex	2321717
F	VG.B33S.50.G14M.E17	VG.B33 suction cup, silicone, 50 Shore, G1/4" male, 17 mm hex	2321718

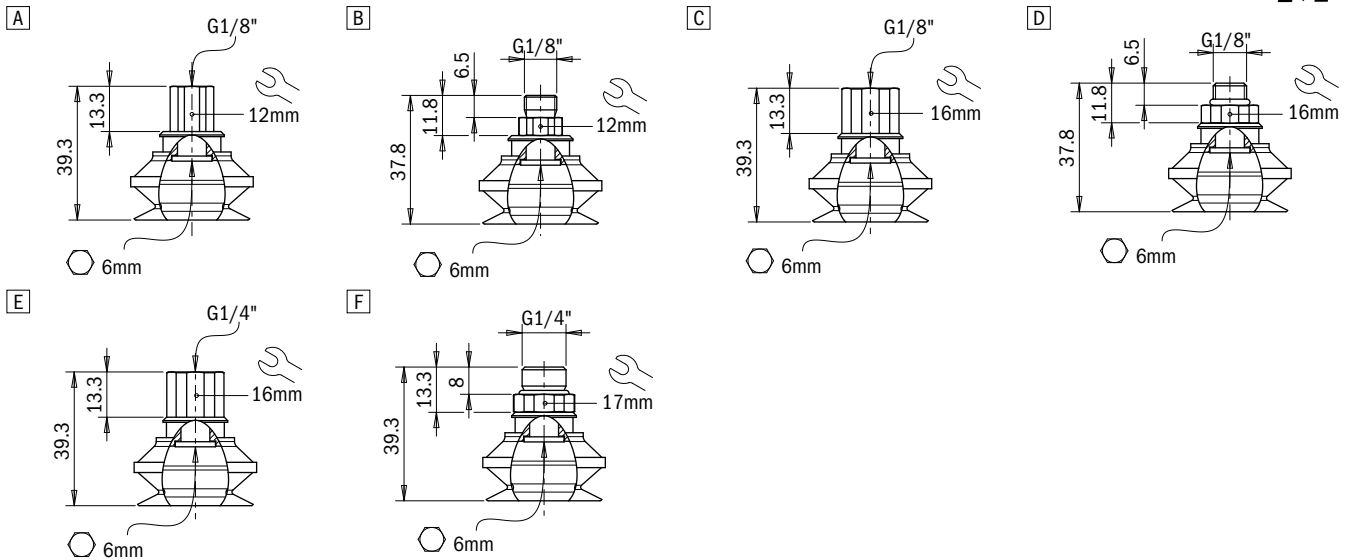

Identification codes

Drawing	Alphanumeric code	Suction cups	Order code
A	VG.B33S.50	VG.B33 suction cup, silicone, 50 Shore	2321713

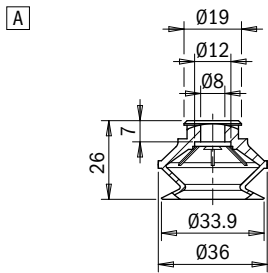

Identification codes

Drawing	Alphanumeric code	Fittings	Order code
A	FT.G18F.E12	G1/8" female fitting, 12 mm hex	2321422
B	FT.G18M.E12	G1/8" male fitting, 12 mm hex	2321424
C	FT.G18F.E16	G1/8" female fitting, 16 mm hex	2321426
D	FT.G18M.E16	G1/8" male fitting, 16 mm hex	2321428
E	FT.G14F.E16	G1/4" female fitting, 16 mm hex	2321430
F	FT.G14M.E17	G1/4" male fitting, 17 mm hex	2321432

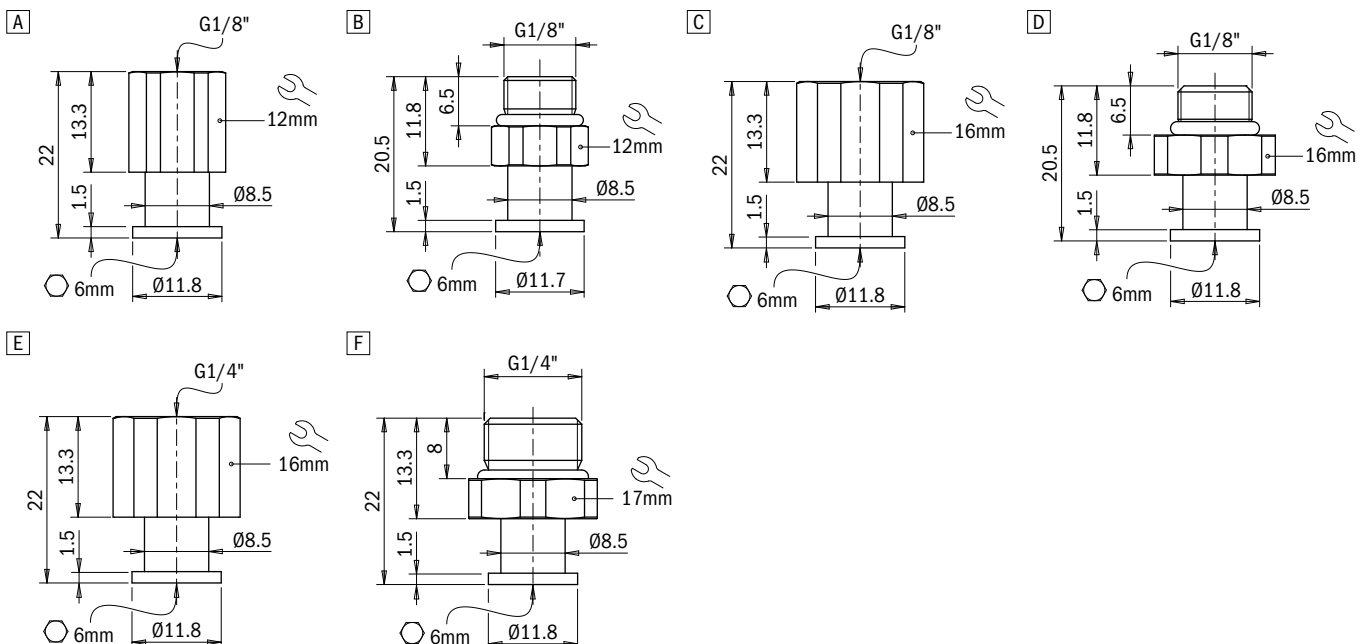

Suction cups / Silicone

VG.B42S bellows suction cups in silicone

- Silicone compound
- Suitable for high working temperatures
- Suitable for objects with flat or slightly curved surfaces
- They enable to compensate for differences in height

Application example

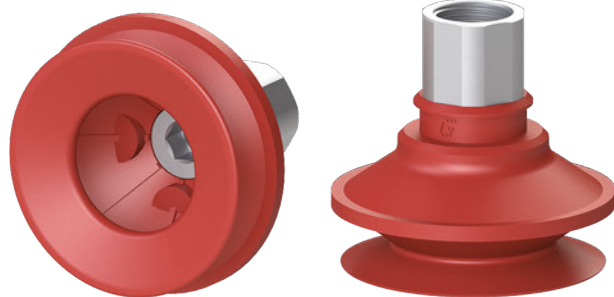
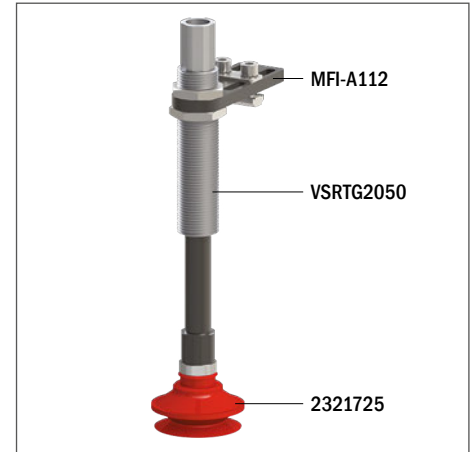

Technical data

Material	Lifting force [N] perpendicular to the surface, at various vacuum levels			Lifting force [N] parallel to the surface, at various vacuum levels			Volume [cm ³]	Min curve radius [mm]	Max vertical movement [mm]	Suction cup weight [g]
	-20 kPa	-60 kPa	-90 kPa	-20 kPa	-60 kPa	-90 kPa				
SIL 50	20	46	53	17.2	26.3	30.7	15	20	12	8.6

Technical features

Material	Color	Hardness	Temperature range
Silicone, SIL	Red	50 Shore	-94 - +392 °F

Identification codes

Drawing	Alphanumeric code	Suction cups with fitting	Order code
A	VG.B42S.50.G18F.E12	VG.B42 suction cup, silicone, 50 Shore, G1/8" female, 12 mm hex	2321719
B	VG.B42S.50.G18M.E12	VG.B42 suction cup, silicone, 50 Shore, G1/8" male, 12 mm hex	2321721
C	VG.B42S.50.G18F.E16	VG.B42 suction cup, silicone, 50 Shore, G1/8" female, 16 mm hex	2321722
D	VG.B42S.50.G18M.E16	VG.B42 suction cup, silicone, 50 Shore, G1/8" male, 16 mm hex	2321723
E	VG.B42S.50.G14F.E16	VG.B42 suction cup, silicone, 50 Shore, G1/4" female, 16 mm hex	2321724
F	VG.B42S.50.G14M.E17	VG.B42 suction cup, silicone, 50 Shore, G1/4" male, 17 mm hex	2321725

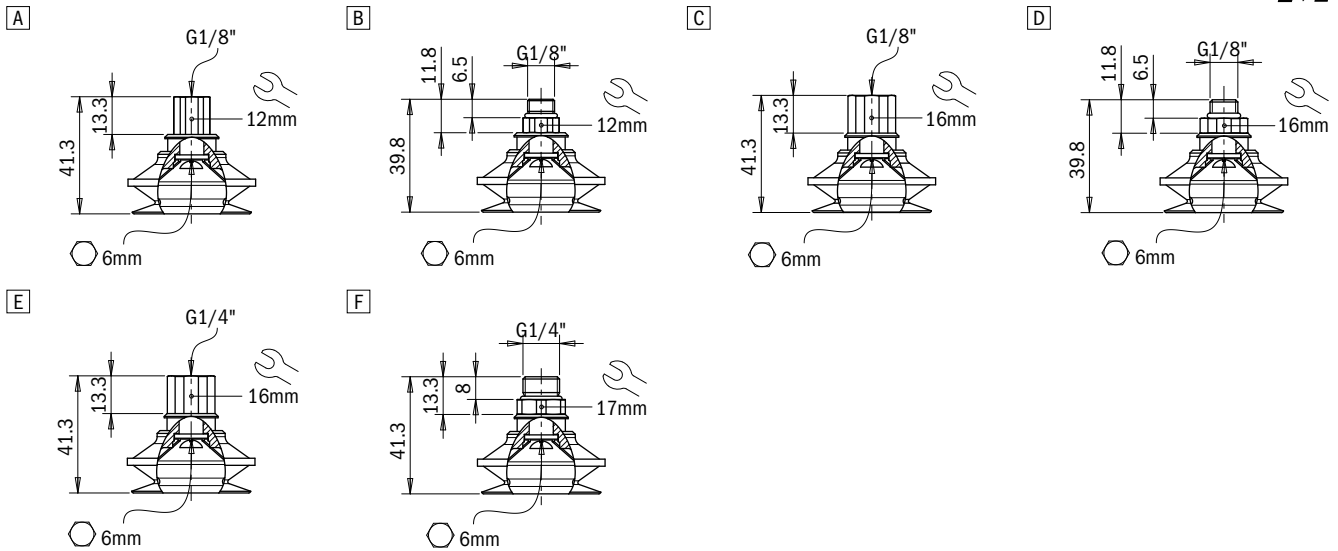

Identification codes

Drawing	Alphanumeric code	Suction cups	Order code
A	VG.B42S.50	VG.B42 suction cup, silicone, 50 Shore	2321720

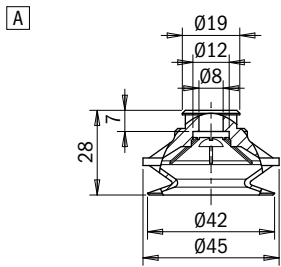

Identification codes

Drawing	Alphanumeric code	Fittings	Order code
A	FT.G18F.E12	G1/8" female fitting, 12 mm hex	2321422
B	FT.G18M.E12	G1/8" male fitting, 12 mm hex	2321424
C	FT.G18F.E16	G1/8" female fitting, 16 mm hex	2321426
D	FT.G18M.E16	G1/8" male fitting, 16 mm hex	2321428
E	FT.G14F.E16	G1/4" female fitting, 16 mm hex	2321430
F	FT.G14M.E17	G1/4" male fitting, 17 mm hex	2321432

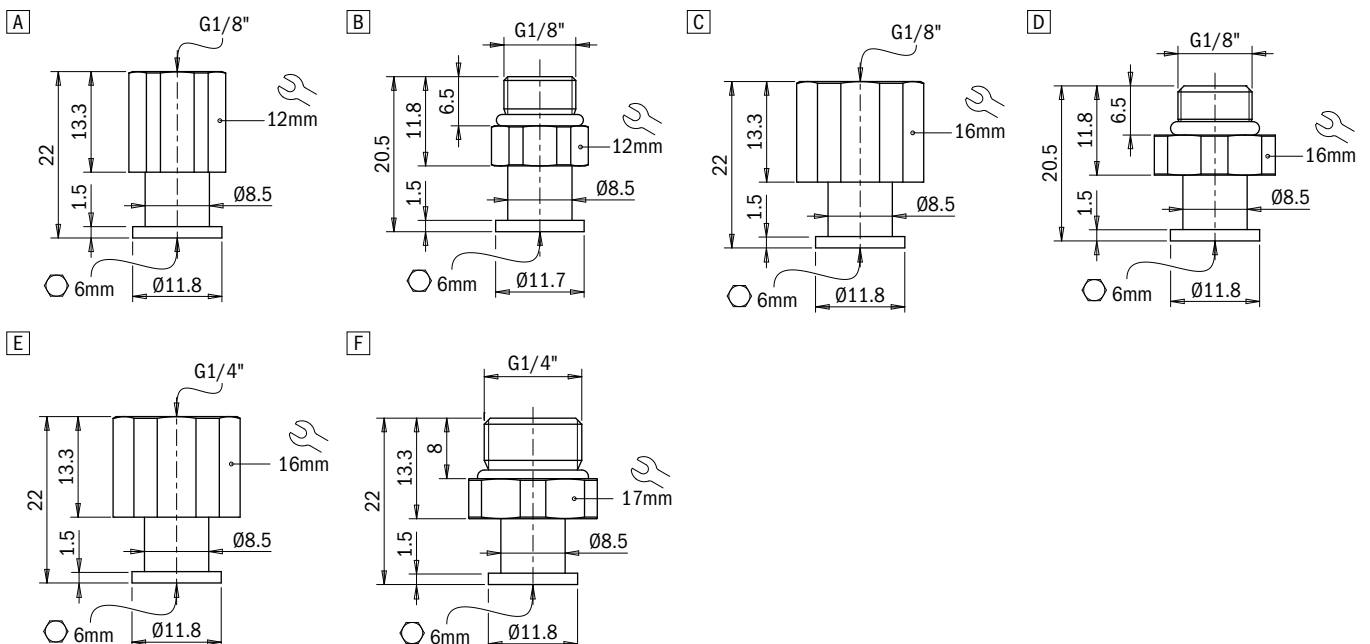

Suction cups / Silicone

VG.B53S bellows suction cups in silicone

- Silicone compound
- Suitable for high working temperatures
- Suitable for objects with flat or slightly curved surfaces
- They enable to compensate for differences in height



Application example

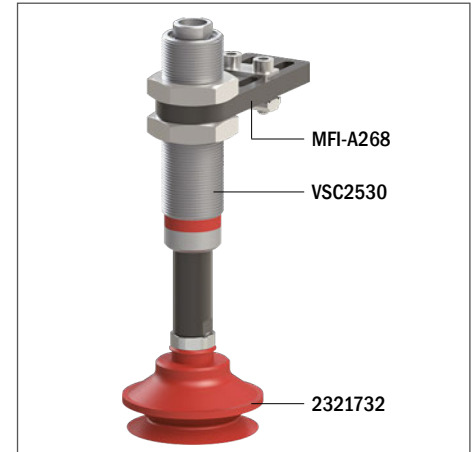

Technical data

Material	Lifting force [N] perpendicular to the surface, at various vacuum levels			Lifting force [N] parallel to the surface, at various vacuum levels			Volume [cm³]	Min curve radius [mm]	Max vertical movement [mm]	Suction cup weight [g]
	-20 kPa	-60 kPa	-90 kPa	-20 kPa	-60 kPa	-90 kPa				
SIL 50	32	64.5	90	24.5	51.3	60.5	32	30	19	15.4

Technical features

Material	Color	Hardness	Temperature range
Silicone, SIL	Red	50 Shore	-94 - +392 °F

Identification codes

Drawing	Alphanumeric code	Suction cups with fitting	Order code
A	VG.B53S.50.G18F.E12	VG.B53 suction cup, silicone, 50 Shore, G1/8" female, 12 mm hex	2321726
B	VG.B53S.50.G18M.E12	VG.B53 suction cup, silicone, 50 Shore, G1/8" male, 12 mm hex	2321728
C	VG.B53S.50.G18F.E16	VG.B53 suction cup, silicone, 50 Shore, G1/8" female, 16 mm hex	2321729
D	VG.B53S.50.G18M.E16	VG.B53 suction cup, silicone, 50 Shore, G1/8" male, 16 mm hex	2321730
E	VG.B53S.50.G14F.E16	VG.B53 suction cup, silicone, 50 Shore, G1/4" female, 16 mm hex	2321731
F	VG.B53S.50.G14M.E17	VG.B53 suction cup, silicone, 50 Shore, G1/4" male, 17 mm hex	2321732

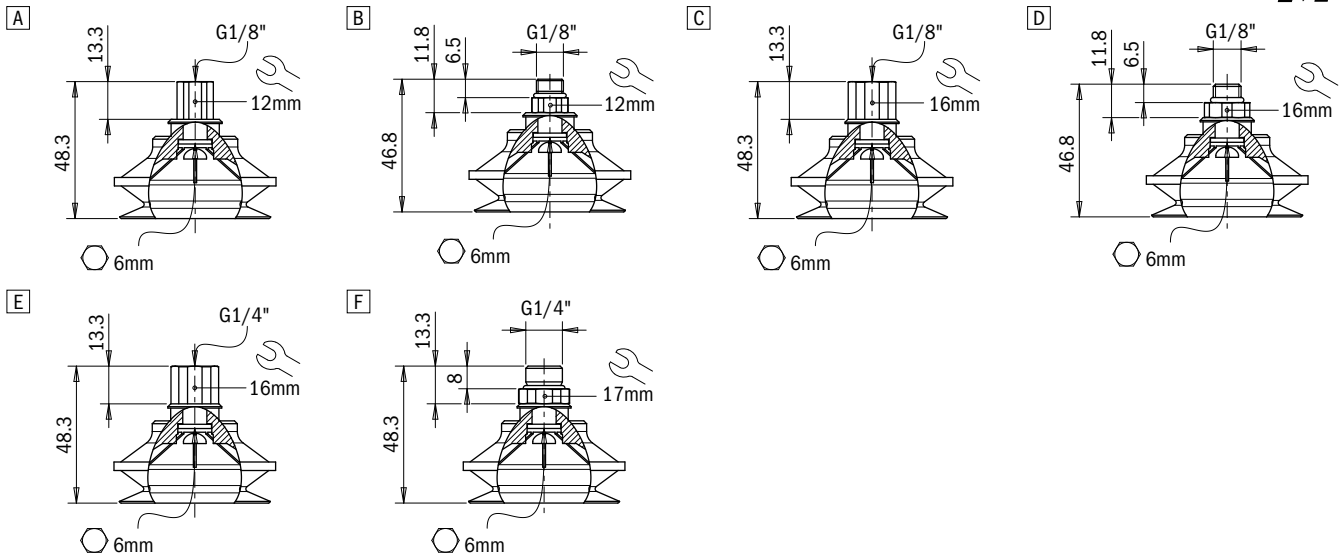

Identification codes

Drawing	Alphanumeric code	Suction cups	Order code
A	VG.B53S.50	VG.B53 suction cup, silicone, 50 Shore	2321727

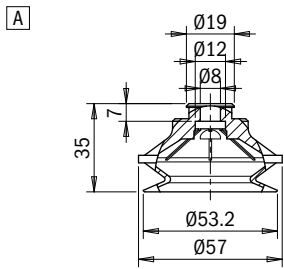

Identification codes

Drawing	Alphanumeric code	Fittings	Order code
A	FT.G18F.E12	G1/8" female fitting, 12 mm hex	2321422
B	FT.G18M.E12	G1/8" male fitting, 12 mm hex	2321424
C	FT.G18F.E16	G1/8" female fitting, 16 mm hex	2321426
D	FT.G18M.E16	G1/8" male fitting, 16 mm hex	2321428
E	FT.G14F.E16	G1/4" female fitting, 16 mm hex	2321430
F	FT.G14M.E17	G1/4" male fitting, 17 mm hex	2321432

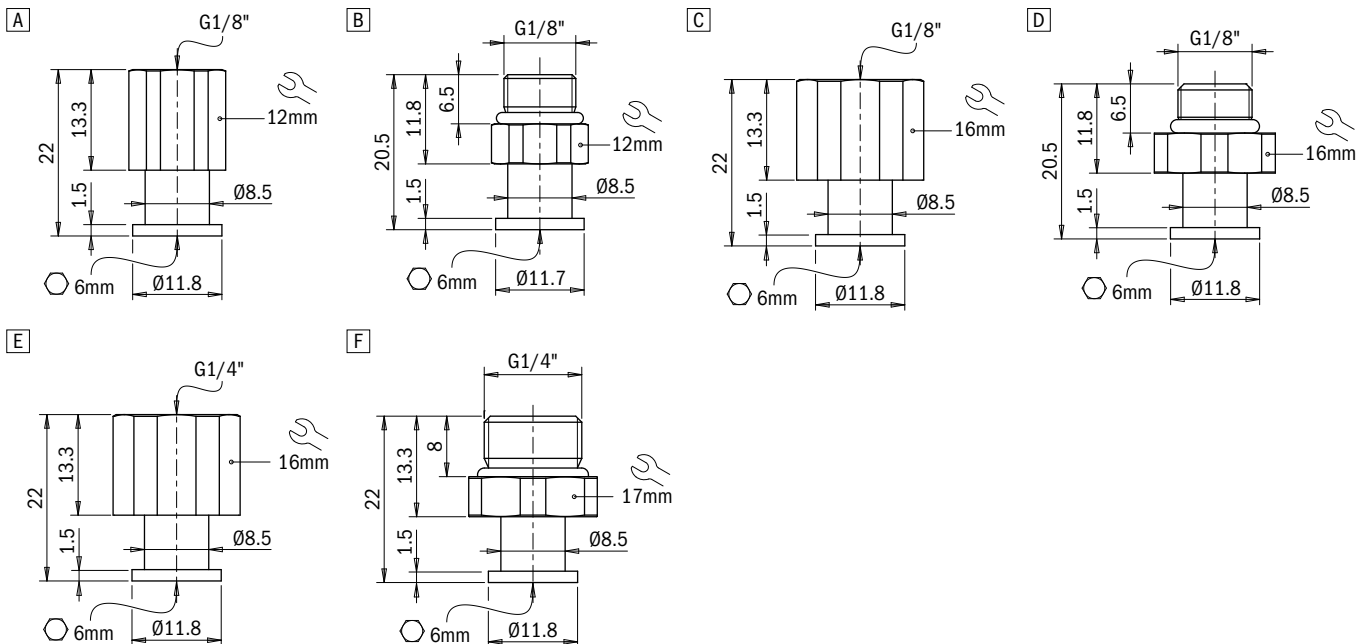

Suction cups / Silicone

VG.B77S bellows suction cups in silicone

- Ideal for palletisation and depalletisation applications
- Silicone compound
- Suitable for high working temperatures
- Suitable for objects with flat or slightly curved surfaces
- They enable to compensate for differences in height

Application example

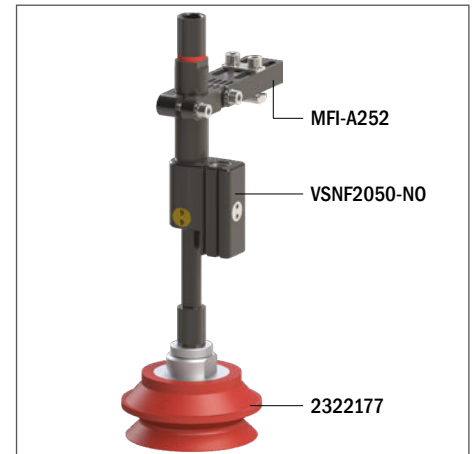

Technical data

Material	Lifting force [N] perpendicular to the surface, at various vacuum levels			Lifting force [N] parallel to the surface, at various vacuum levels			Volume [cm ³]	Min curve radius [mm]	Max vertical movement [mm]	Suction cup weight [g]
	-20 kPa	-60 kPa	-90 kPa	-20 kPa	-60 kPa	-90 kPa				
SIL 50	78	173	231	66	125	157	110	40	24	37

Technical features

Material	Color	Hardness	Temperature range
Silicone, SIL	Red	50 Shore	-94 - +392 °F

Identification codes

Drawing	Alphanumeric code	Suction cups with fitting	Order code
A	VG.B77S.50.G14M	VG.B77 suction cup, silicone, 50 Shore, G1/4" male	2322177
B	VG.B77S.50.G14F	VG.B77 suction cup, silicone, 50 Shore, G1/4" female	2322178
C	VG.B77S.50.G38M	VG.B77 suction cup, silicone, 50 Shore, G3/8" male	2322179
D	VG.B77S.50.G38F	VG.B77 suction cup, silicone, 50 Shore, G3/8" female	2322180

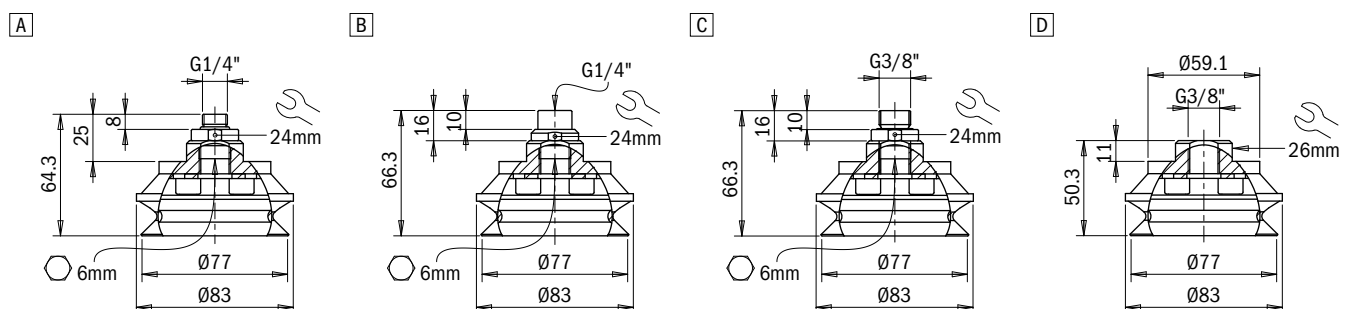

Suction cups / EPDM-HNBR

VG.B6 EPDM-HNBR bellows suction cups

- Suitable for handling plastic parts
- Suitable for objects with flat or slightly curved surfaces
- They enable to compensate for differences in height
- The HNBR version enables to work at high temperatures, whereas silicone or other mixtures may release traces of material. Ideal for applications where contamination of the material must be avoided (PWIS)
- The HNBR compound is robust and wear resistant, suitable for the removal of hot plastic parts from the relevant moulds



Application example

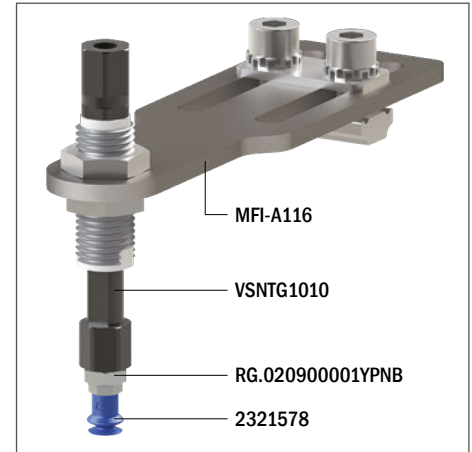

Technical data

Material	Lifting force [N] perpendicular to the surface, at various vacuum levels			Lifting force [N] parallel to the surface, at various vacuum levels			Volume [cm ³]	Min curve radius [mm]	Max vertical movement [mm]	Suction cup weight [g]
	-20 kPa	-60 kPa	-90 kPa	-20 kPa	-60 kPa	-90 kPa				
EPDM 50	0.25	0.78	1.1	–	–	–	0.05	1.5	1.5	0.1
HNBR 60	0.25	0.78	1.1	–	–	–	0.05	1.5	1.5	0.1

Technical features

Material	Color	Hardness	Temperature range
EPDM	Black	50 Shore	-40 - +212 °F
HNBR	Blue	60 Shore	-13 - +302 °F

Identification codes

Drawing	Alphanumeric code	Suction cups with fitting	Order code
A	VG.B6E.50.M3M.E5	VG.B6 suction cup, EPDM, 50 Shore, M3 male, 5 mm hex	2321576
A	VG.B6H.60.M3M.E5	VG.B6 suction cup, HNBR, 60 Shore, M3 male, 5 mm hex	2321578
B	VG.B6E.50.M5M.E8	VG.B6 suction cup, EPDM, 50 Shore, M5 male, 8 mm hex	2321076
B	VG.B6H.60.M5M.E8	VG.B6 suction cup, HNBR, 60 Shore, M5 male, 8 mm hex	2321078

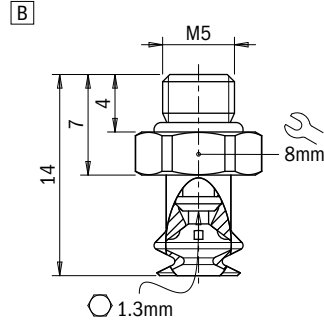
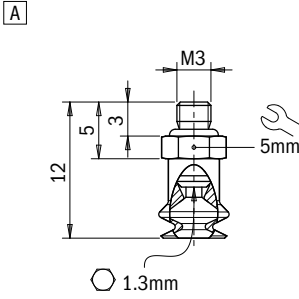

Identification codes

Drawing	Alphanumeric code	Suction cups	Order code
A	VG.B6E.50	VG.B6 suction cup, EPDM, 50 Shore	2321577
A	VG.B6H.60	VG.B6 suction cup, HNBR, 60 Shore	2321579

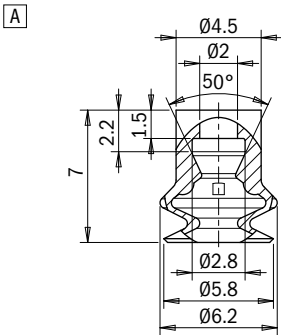

Click for Pricing & Add to Cart



Identification codes

Drawing	Alphanumeric code	Fittings	Order code
A	FT.M3M.E5	M3 male fitting, hex, 5 mm	2321402
B	FT.M5M.E8.06	M5 male fitting, hex, 8 mm	2321005

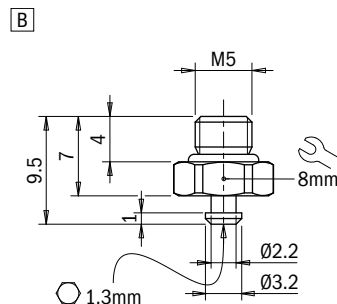
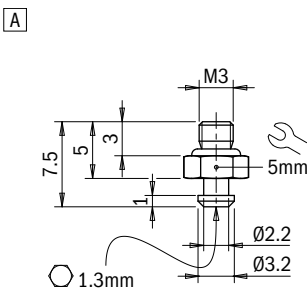

Suction cups / EPDM-HNBR

VG.B9 EPDM-HNBR bellows suction cups

- Suitable for handling plastic parts
- Suitable for objects with flat or slightly curved surfaces
- They enable to compensate for differences in height
- The HNBR version enables to work at high temperatures, whereas silicone or other mixtures may release traces of material. Ideal for applications where contamination of the material must be avoided (PWIS)
- The HNBR compound is robust and wear resistant, suitable for the removal of hot plastic parts from the relevant moulds

Application example

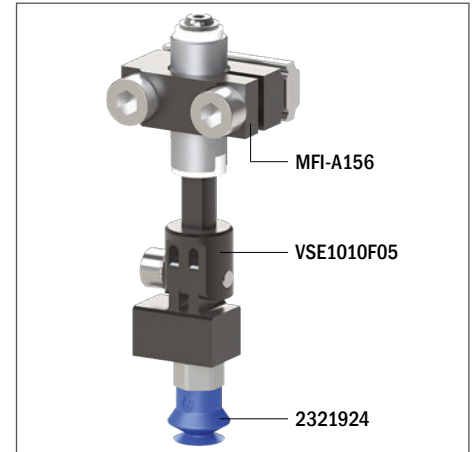

Technical data

Material	Lifting force [N] perpendicular to the surface, at various vacuum levels			Lifting force [N] parallel to the surface, at various vacuum levels			Volume [cm ³]	Min curve radius [mm]	Max vertical movement [mm]	Suction cup weight [g]
	-20 kPa	-60 kPa	-90 kPa	-20 kPa	-60 kPa	-90 kPa				
EPDM 50	0.82	1.5	2.3	–	–	–	0.15	1.9	3.5	0.3
HNBR 60	0.82	1.5	2.3	–	–	–	0.15	1.9	3.5	0.3

Technical features

Material	Color	Hardness	Temperature range
EPDM	Black	50 Shore	-40 - +212 °F
HNBR	Blue	60 Shore	-13 - +302 °F

Identification codes			
Drawing	Alphanumeric code	Suction cups with fitting	Order code
A	VG.B9E.50.M5M.E8	VG.B9 suction cup, EPDM, 50 Shore, M5 male, 8 mm hex	2321922
A	VG.B9H.60.M5M.E8	VG.B9 suction cup, HNBR, 60 Shore, M5 male, 8 mm hex	2321924

A

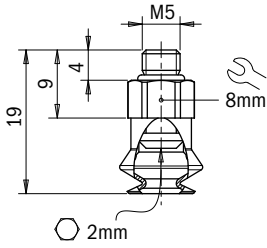

Identification codes			
Drawing	Alphanumeric code	Suction cups	Order code
A	VG.B9E.50	VG.B9 suction cup, EPDM, 50 Shore	2321923
A	VG.B9H.60	VG.B9 suction cup, HNBR, 60 Shore	2321925

A

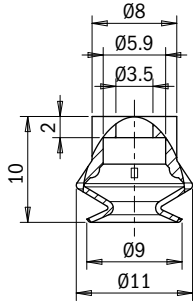

Identification codes			
Drawing	Alphanumeric code	Fittings	Order code
A	FT.M5M.E8.05	M5 male fitting, 8 mm hex	2321405

A

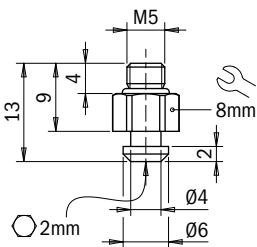

Suction cups / EPDM-HNBR

VG.B11 EPDM-HNBR bellows suction cups

- Suitable for handling plastic parts
- Suitable for objects with flat or slightly curved surfaces
- They enable to compensate for differences in height
- The HNBR version enables to work at high temperatures, whereas silicone or other mixtures may release traces of material. Ideal for applications where contamination of the material must be avoided (PWIS)
- The HNBR compound is robust and wear resistant, suitable for the removal of hot plastic parts from the relevant moulds

Application example

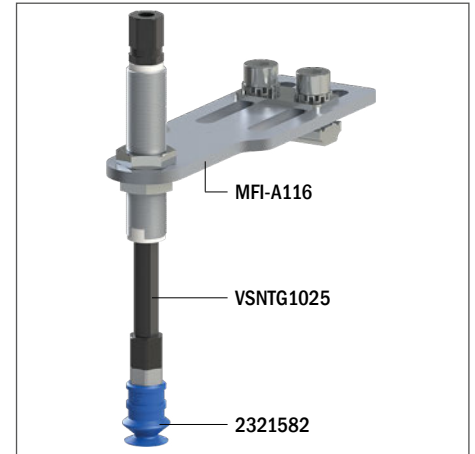

Technical data

Material	Lifting force [N] perpendicular to the surface, at various vacuum levels			Lifting force [N] parallel to the surface, at various vacuum levels			Volume [cm ³]	Min curve radius [mm]	Max vertical movement [mm]	Suction cup weight [g]
	-20 kPa	-60 kPa	-90 kPa	-20 kPa	-60 kPa	-90 kPa				
EPDM 50	1.3	3.4	4.6	1.7	2.42	2.81	0.48	4	4.5	0.7
HNBR 60	1.3	3.4	4.6	1.7	2.42	2.81	0.48	4	4.5	0.7

Technical features

Material	Color	Hardness	Temperature range
EPDM	Black	50 Shore	-40 - +212 °F
HNBR	Blue	60 Shore	-13 - +302 °F

Identification codes

Drawing	Alphanumeric code	Suction cups with fitting	Order code
A	VG.B11E.50.M5F.E8	VG.B11 suction cup, EPDM, 50 Shore, M5 female, 8 mm hex	2321580
B	VG.B11E.50.M5M.E8	VG.B11 suction cup, EPDM, 50 Shore, M5 male, 8 mm hex	2321582
C	VG.B11E.50.G18F.E13	VG.B11 suction cup, EPDM, 50 Shore, G1/8" female, 13 mm hex	2321583
D	VG.B11E.50.G18M.E13	VG.B11 suction cup, EPDM, 50 Shore, G1/8" male, 13 mm hex	2321584
A	VG.B11H.60.M5F.E8	VG.B11 suction cup, HNBR, 60 Shore, M5 female, 8 mm hex	2321585
B	VG.B11H.60.M5M.E8	VG.B11 suction cup, HNBR, 60 Shore, M5 male, 8 mm hex	2321587
C	VG.B11H.60.G18F.E13	VG.B11 suction cup, HNBR, 60 Shore, G1/8" female, 13 mm hex	2321588
D	VG.B11H.60.G18M.E13	VG.B11 suction cup, HNBR, 60 Shore, G1/8" male, 13 mm hex	2321589

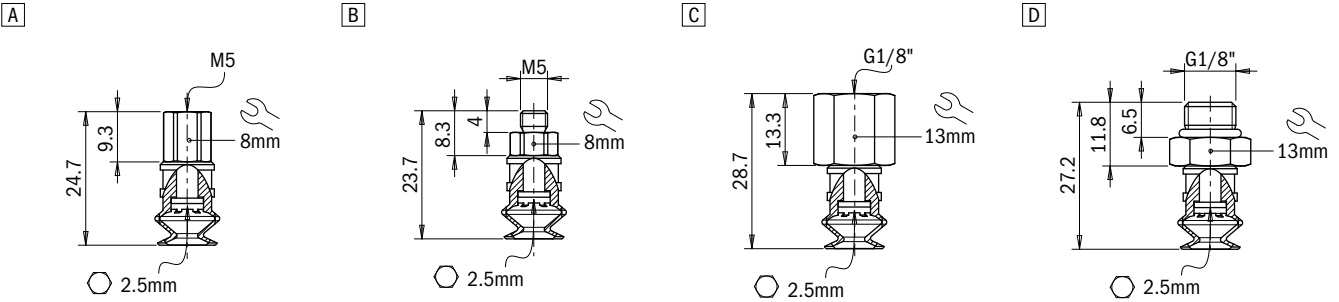

Identification codes

Drawing	Alphanumeric code	Suction cups	Order code
A	VG.B11E.50	VG.B11 suction cup, EPDM, 50 Shore	2321581
A	VG.B11H.60	VG.B11 suction cup, HNBR, 60 Shore	2321586

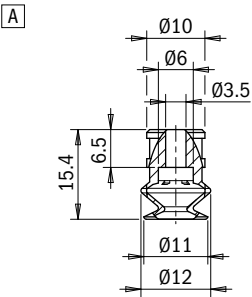

Identification codes

Drawing	Alphanumeric code	Fittings	Order code
A	FT.M5F.E8	M5 female fitting, 8 mm hex	2321408
B	FT.M5M.E8	M5 male fitting, 8 mm hex	2321410
C	FT.G18F.E13	G1/8" female fitting, 13 mm hex	2321412
D	FT.G18M.E13	G1/8" male fitting, 13 mm hex	2321414

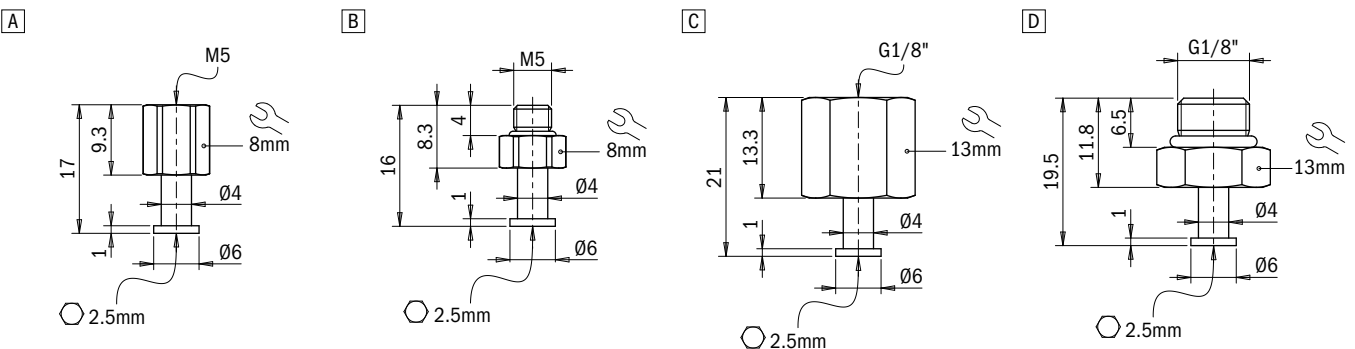

Suction cups / EPDM-HNBR

VG.B16 EPDM-HNBR bellows suction cups

- Suitable for handling plastic parts
- Suitable for objects with flat or slightly curved surfaces
- They enable to compensate for differences in height
- The HNBR version enables to work at high temperatures, whereas silicone or other mixtures may release traces of material. Ideal for applications where contamination of the material must be avoided (PWIS)
- The HNBR compound is robust and wear resistant, suitable for the removal of hot plastic parts from the relevant moulds

Application example

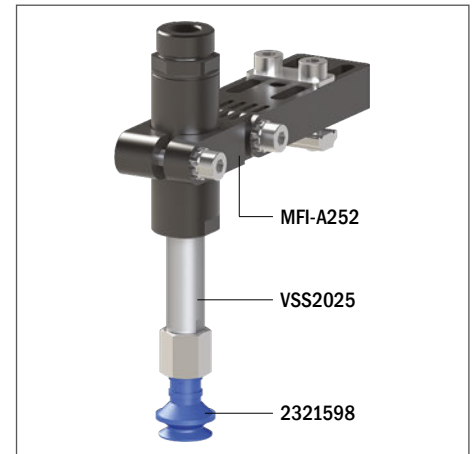

Technical data

Material	Lifting force [N] perpendicular to the surface, at various vacuum levels			Lifting force [N] parallel to the surface, at various vacuum levels			Volume [cm ³]	Min curve radius [mm]	Max vertical movement [mm]	Suction cup weight [g]
	-20 kPa	-60 kPa	-90 kPa	-20 kPa	-60 kPa	-90 kPa				
EPDM 50	3	5.8	8.5	1.71	3.1	3.9	1.1	5	6.5	2.1
HNBR 60	3	5.8	8.5	1.71	3.1	3.9	1.1	5	6.5	2.1

Technical features

Material	Color	Hardness	Temperature range
EPDM	Black	50 Shore	-40 - +212 °F
HNBR	Blue	60 Shore	-13 - +302 °F

Identification codes

Drawing	Alphanumeric code	Suction cups with fitting	Order code
A	VG.B16E.50.M5F.E8	VG.B16 suction cup, EPDM, 50 Shore, M5 female, 8 mm hex	2321590
B	VG.B16E.50.M5M.E8	VG.B16 suction cup, EPDM, 50 Shore, M5 male, 8 mm hex	2321592
C	VG.B16E.50.G18F.E13	VG.B16 suction cup, EPDM, 50 Shore, G1/8" female, 13 mm hex	2321593
D	VG.B16E.50.G18M.E13	VG.B16 suction cup, EPDM, 50 Shore, G1/8" male, 13 mm hex	2321594
A	VG.B16H.60.M5F.E8	VG.B16 suction cup, HNBR, 60 Shore, M5 female, 8 mm hex	2321595
B	VG.B16H.60.M5M.E8	VG.B16 suction cup, HNBR, 60 Shore, M5 male, 8 mm hex	2321597
C	VG.B16H.60.G18F.E13	VG.B16 suction cup, HNBR, 60 Shore, G1/8" female, 13 mm hex	2321598
D	VG.B16H.60.G18M.E13	VG.B16 suction cup, HNBR, 60 Shore, G1/8" male, 13 mm hex	2321599

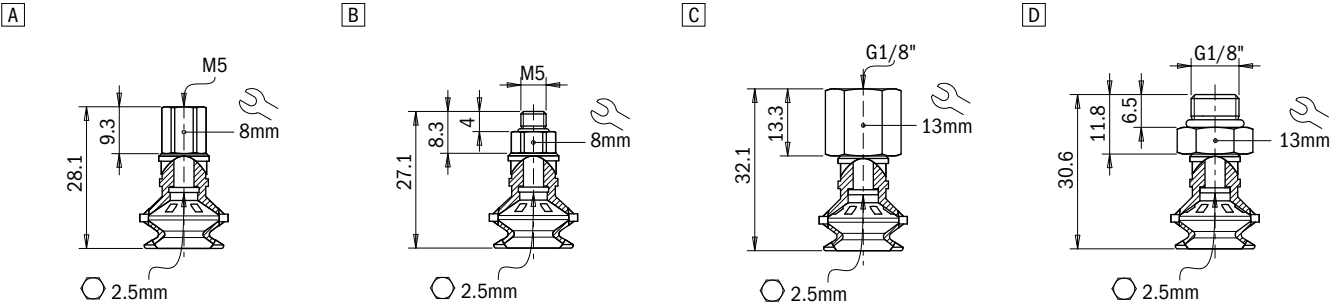

Identification codes

Drawing	Alphanumeric code	Suction cups	Order code
A	VG.B16E.50	VG.B16 suction cup, EPDM, 50 Shore	2321591
A	VG.B16H.60	VG.B16 suction cup, HNBR, 60 Shore	2321596

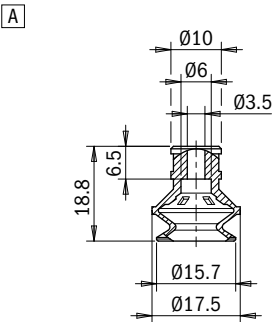

Identification codes

Drawing	Alphanumeric code	Fittings	Order code
A	FT.M5F.E8	M5 female fitting, 8 mm hex	2321408
B	FT.M5M.E8	M5 male fitting, 8 mm hex	2321410
C	FT.G18F.E13	G1/8" female fitting, 13 mm hex	2321412
D	FT.G18M.E13	G1/8" male fitting, 13 mm hex	2321414

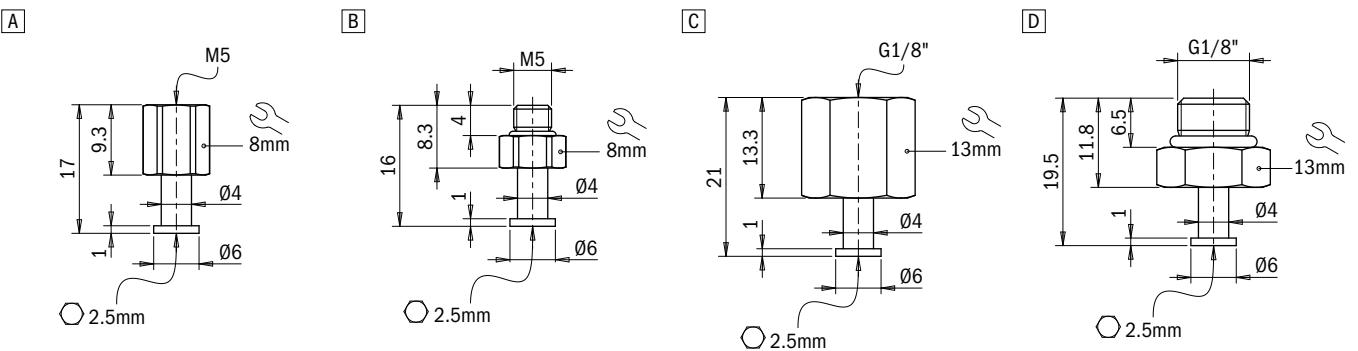

Suction cups / EPDM-HNBR

VG.B22 EPDM-HNBR bellows suction cups

- Suitable for handling plastic parts
- Suitable for objects with flat or slightly curved surfaces
- They enable to compensate for differences in height
- The HNBR version enables to work at high temperatures, whereas silicone or other mixtures may release traces of material. Ideal for applications where contamination of the material must be avoided (PWIS)
- The HNBR compound is robust and wear resistant, suitable for the removal of hot plastic parts from the relevant moulds

Application example

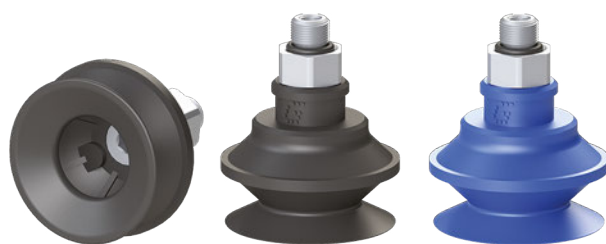
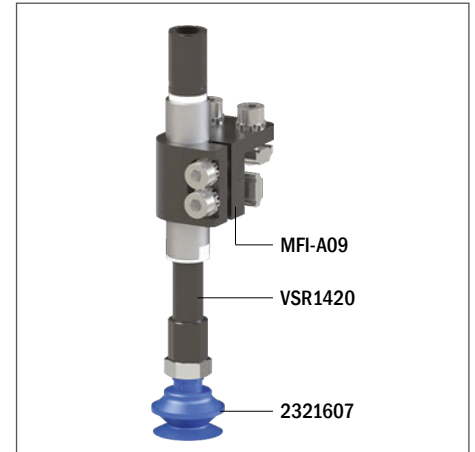

Technical data

Material	Lifting force [N] perpendicular to the surface, at various vacuum levels			Lifting force [N] parallel to the surface, at various vacuum levels			Volume [cm ³]	Min curve radius [mm]	Max vertical movement [mm]	Suction cup weight [g]
	-20 kPa	-60 kPa	-90 kPa	-20 kPa	-60 kPa	-90 kPa				
EPDM 50	5.5	13	14	2.92	5.5	8.3	2.7	10	10	1.8
HNBR 60	5.5	13	14	2.92	5.5	8.3	2.7	10	10	1.8

Technical features

Material	Color	Hardness	Temperature range
EPDM	Black	50 Shore	-40 - +212 °F
HNBR	Blue	60 Shore	-13 - +302 °F

Identification codes

Drawing	Alphanumeric code	Suction cups with fitting	Order code
A	VG.B22E.50.M5F.E8	VG.B22 suction cup, EPDM, 50 Shore, M5 female, 8 mm hex	2321600
B	VG.B22E.50.M5M.E8	VG.B22 suction cup, EPDM, 50 Shore, M5 male, 8 mm hex	2321602
C	VG.B22E.50.G18F.E13	VG.B22 suction cup, EPDM, 50 Shore, G1/8" female, 13 mm hex	2321603
D	VG.B22E.50.G18M.E13	VG.B22 suction cup, EPDM, 50 Shore, G1/8" male, 13 mm hex	2321604
A	VG.B22H.60.M5F.E8	VG.B22 suction cup, HNBR, 60 Shore, M5 female, 8 mm hex	2321605
B	VG.B22H.60.M5M.E8	VG.B22 suction cup, HNBR, 60 Shore, M5 male, 8 mm hex	2321607
C	VG.B22H.60.G18F.E13	VG.B22 suction cup, HNBR, 60 Shore, G1/8" female, 13 mm hex	2321608
D	VG.B22H.60.G18M.E13	VG.B22 suction cup, HNBR, 60 Shore, G1/8" male, 13 mm hex	2321609

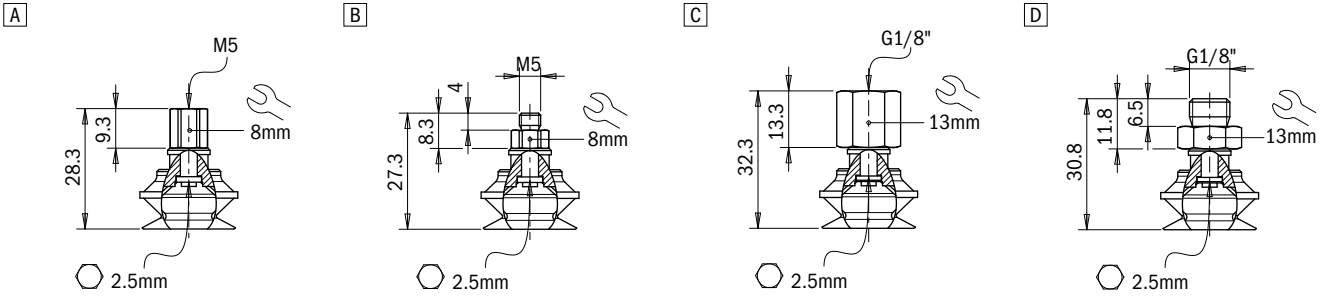

Identification codes

Drawing	Alphanumeric code	Suction cups	Order code
A	VG.B22E.50	VG.B22 suction cup, EPDM, 50 Shore	2321601
A	VG.B22H.60	VG.B22 suction cup, HNBR, 60 Shore	2321606



Click for Pricing & Add to Cart

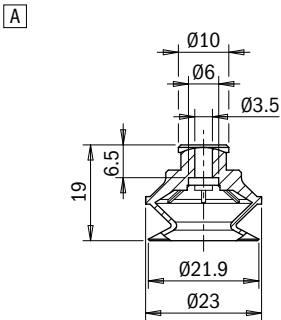

Identification codes

Drawing	Alphanumeric code	Fittings	Order code
A	FT.M5F.E8	M5 female fitting, 8 mm hex	2321408
B	FT.M5M.E8	M5 male fitting, 8 mm hex	2321410
C	FT.G18F.E13	G1/8" female fitting, 13 mm hex	2321412
D	FT.G18M.E13	G1/8" male fitting, 13 mm hex	2321414

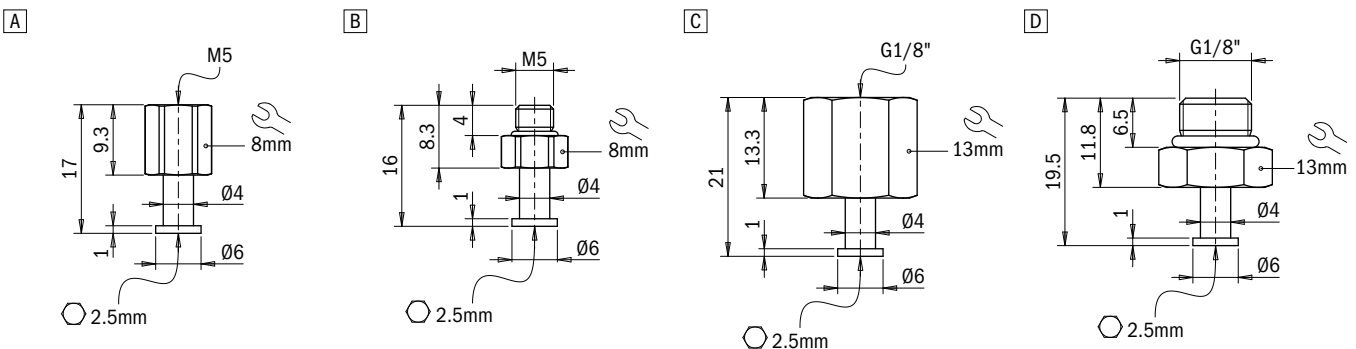

Suction cups / EPDM-HNBR

VG.B33 EPDM-HNBR bellows suction cups

- Suitable for handling plastic parts
- Suitable for objects with flat or slightly curved surfaces
- They enable to compensate for differences in height
- The HNBR version enables to work at high temperatures, whereas silicone or other mixtures may release traces of material. Ideal for applications where contamination of the material must be avoided (PWIS)
- The HNBR compound is robust and wear resistant, suitable for the removal of hot plastic parts from the relevant moulds

Application example

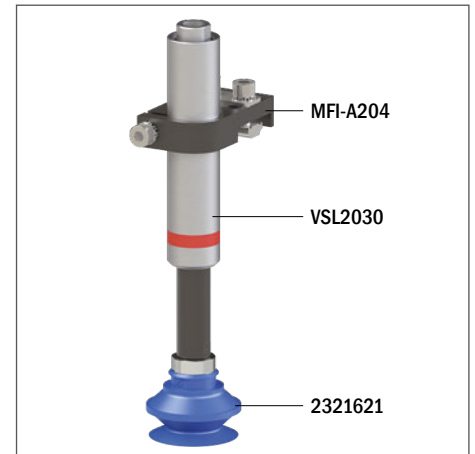

Technical data

Material	Lifting force [N] perpendicular to the surface, at various vacuum levels			Lifting force [N] parallel to the surface, at various vacuum levels			Volume [cm ³]	Min curve radius [mm]	Max vertical movement [mm]	Suction cup weight [g]
	-20 kPa	-60 kPa	-90 kPa	-20 kPa	-60 kPa	-90 kPa				
EPDM 50	12	23	26	9.5	16.6	22.5	10	15	15	5.8
HNBR 60	12	23	26	9.5	16.6	22.5	10	15	15	5.8

Technical features

Material	Color	Hardness	Temperature range
EPDM	Black	50 Shore	-40 - +212 °F
HNBR	Blue	60 Shore	-13 - +302 °F

Identification codes

Drawing	Alphanumeric code	Suction cups with fitting	Order code
A	VG.B33E.50.G18F.E12	VG.B33 suction cup, EPDM, 50 Shore, G1/8" female, 12 mm hex	2321610
B	VG.B33E.50.G18M.E12	VG.B33 suction cup, EPDM, 50 Shore, G1/8" male, 12 mm hex	2321612
C	VG.B33E.50.G18F.E16	VG.B33 suction cup, EPDM, 50 Shore, G1/8" female, 16 mm hex	2321613
D	VG.B33E.50.G18M.E16	VG.B33 suction cup, EPDM, 50 Shore, G1/8" male, 16 mm hex	2321614
E	VG.B33E.50.G14F.E16	VG.B33 suction cup, EPDM, 50 Shore, G1/4" female, 16 mm hex	2321615
F	VG.B33E.50.G14M.E17	VG.B33 suction cup, EPDM, 50 Shore, G1/4" male, 17 mm hex	2321616
A	VG.B33H.60.G18F.E12	VG.B33 suction cup, HNBR, 60 Shore, G1/8" female, 12 mm hex	2321617
B	VG.B33H.60.G18M.E12	VG.B33 suction cup, HNBR, 60 Shore, G1/8" male, 12 mm hex	2321619
C	VG.B33H.60.G18F.E16	VG.B33 suction cup, HNBR, 60 Shore, G1/8" female, 16 mm hex	2321620
D	VG.B33H.60.G18M.E16	VG.B33 suction cup, HNBR, 60 Shore, G1/8" male, 16 mm hex	2321621
E	VG.B33H.60.G14F.E16	VG.B33 suction cup, HNBR, 60 Shore, G1/4" female, 16 mm hex	2321622
F	VG.B33H.60.G14M.E17	VG.B33 suction cup, HNBR, 60 Shore, G1/4" male, 17 mm hex	2321623

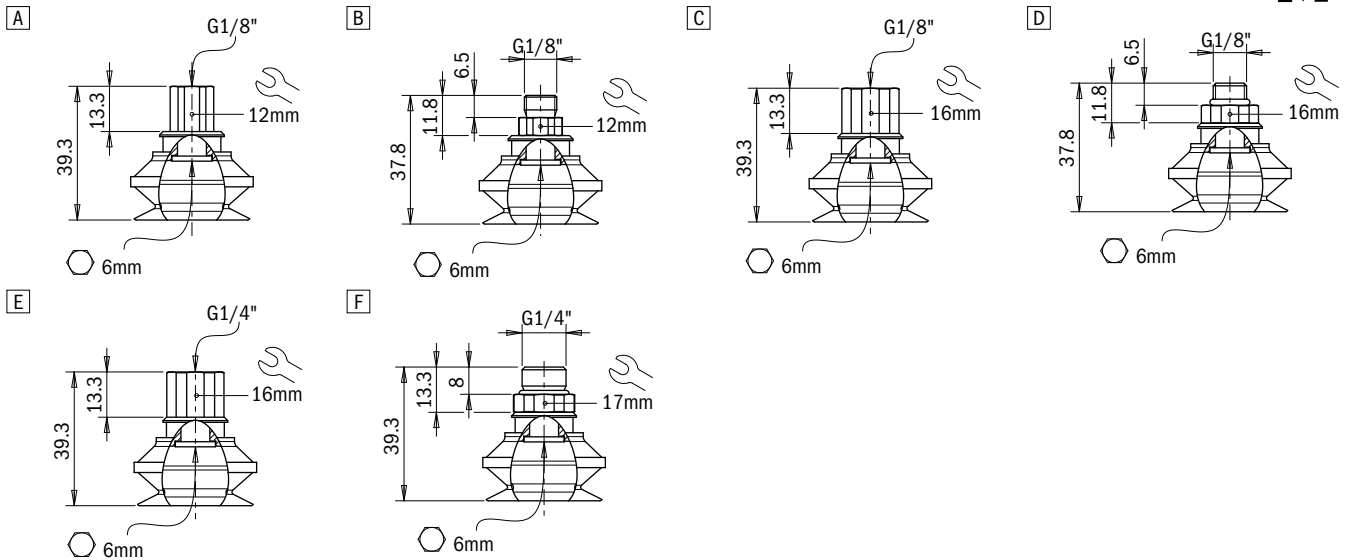

Identification codes

Drawing	Alphanumeric code	Suction cups	Order code
A	VG.B33E.50	VG.B33 suction cup, EPDM, 50 Shore	2321611
A	VG.B33H.60	VG.B33 suction cup, HNBR, 60 Shore	2321618

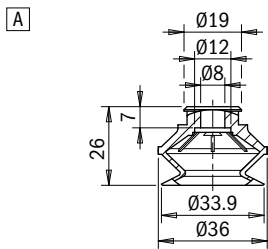

Identification codes

Drawing	Alphanumeric code	Fittings	Order code
A	FT.G18F.E12	G1/8" female fitting, 12 mm hex	2321422
B	FT.G18M.E12	G1/8" male fitting, 12 mm hex	2321424
C	FT.G18F.E16	G1/8" female fitting, 16 mm hex	2321426
D	FT.G18M.E16	G1/8" male fitting, 16 mm hex	2321428
E	FT.G14F.E16	G1/4" female fitting, 16 mm hex	2321430
F	FT.G14M.E17	G1/4" male fitting, 17 mm hex	2321432

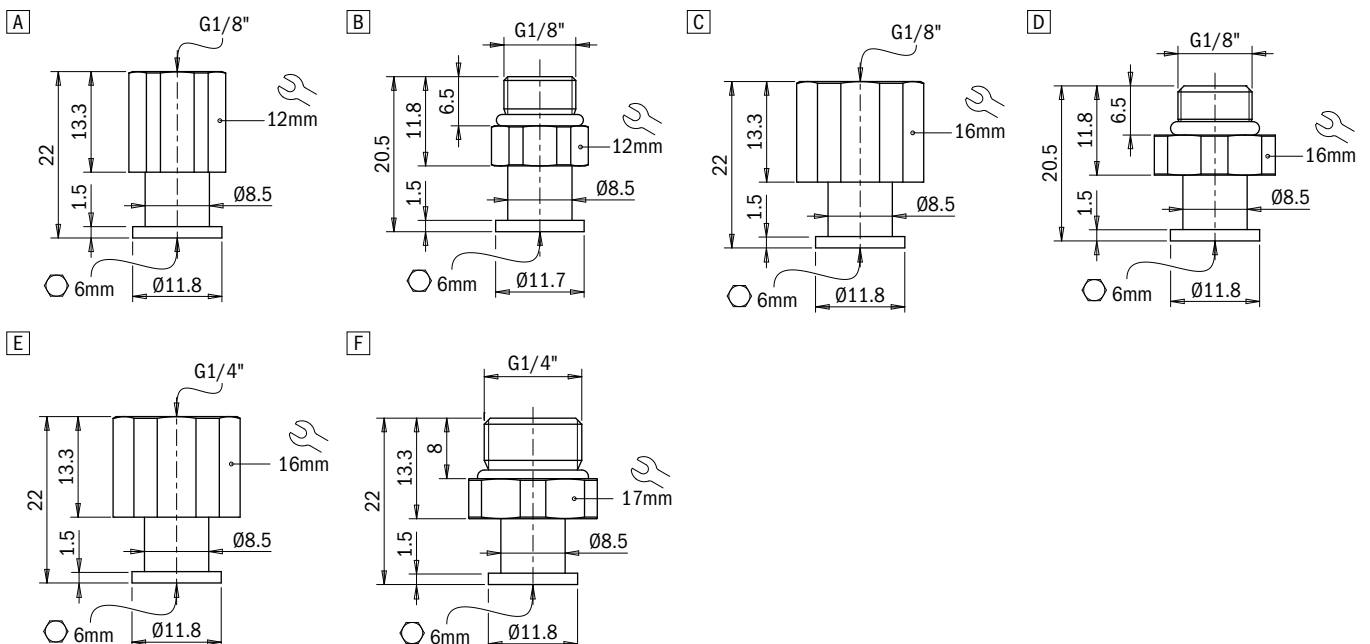

Suction cups / EPDM-HNBR

VG.B42 EPDM-HNBR bellows suction cups

- Suitable for handling plastic parts
- Suitable for objects with flat or slightly curved surfaces
- They enable to compensate for differences in height
- The HNBR version enables to work at high temperatures, whereas silicone or other mixtures may release traces of material. Ideal for applications where contamination of the material must be avoided (PWIS)
- The HNBR compound is robust and wear resistant, suitable for the removal of hot plastic parts from the relevant moulds

Application example

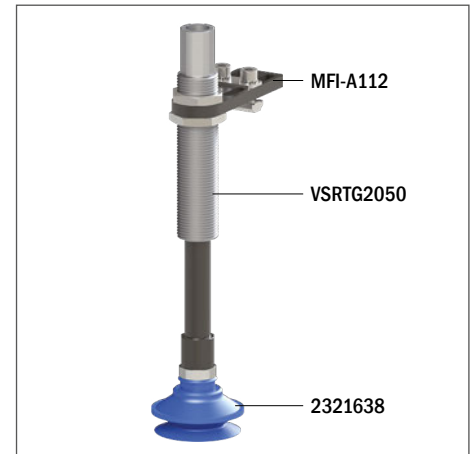

Technical data

Material	Lifting force [N] perpendicular to the surface, at various vacuum levels			Lifting force [N] parallel to the surface, at various vacuum levels			Volume [cm ³]	Min curve radius [mm]	Max vertical movement [mm]	Suction cup weight [g]
	-20 kPa	-60 kPa	-90 kPa	-20 kPa	-60 kPa	-90 kPa				
EPDM 50	20	46	53	17.2	26.3	30.7	15	20	12	8.6
HNBR 60	20	46	53	17.2	26.3	30.7	15	20	12	8.6

Technical features

Material	Color	Hardness	Temperature range
EPDM	Black	50 Shore	-40 - +212 °F
HNBR	Blue	60 Shore	-13 - +302 °F

Identification codes

Drawing	Alphanumeric code	Suction cups with fitting	Order code
A	VG.B42E.50.G18F.E12	VG.B42 suction cup, EPDM, 50 Shore, G1/8" female, 12 mm hex	2321624
B	VG.B42E.50.G18M.E12	VG.B42 suction cup, EPDM, 50 Shore, G1/8" male, 12 mm hex	2321626
C	VG.B42E.50.G18F.E16	VG.B42 suction cup, EPDM, 50 Shore, G1/8" female, 16 mm hex	2321627
D	VG.B42E.50.G18M.E16	VG.B42 suction cup, EPDM, 50 Shore, G1/8" male, 16 mm hex	2321628
E	VG.B42E.50.G14F.E16	VG.B42 suction cup, EPDM, 50 Shore, G1/4" female, 16 mm hex	2321629
F	VG.B42E.50.G14M.E17	VG.B42 suction cup, EPDM, 50 Shore, G1/4" male, 17 mm hex	2321630
A	VG.B42H.60.G18F.E12	VG.B42 suction cup, HNBR, 60 Shore, G1/8" female, 12 mm hex	2321631
B	VG.B42H.60.G18M.E12	VG.B42 suction cup, HNBR, 60 Shore, G1/8" male, 12 mm hex	2321633
C	VG.B42H.60.G18F.E16	VG.B42 suction cup, HNBR, 60 Shore, G1/8" female, 16 mm hex	2321635
D	VG.B42H.60.G18M.E16	VG.B42 suction cup, HNBR, 60 Shore, G1/8" male, 16 mm hex	2321636
E	VG.B42H.60.G14F.E16	VG.B42 suction cup, HNBR, 60 Shore, G1/4" female, 16 mm hex	2321637
F	VG.B42H.60.G14M.E17	VG.B42 suction cup, HNBR, 60 Shore, G1/4" male, 17 mm hex	2321638

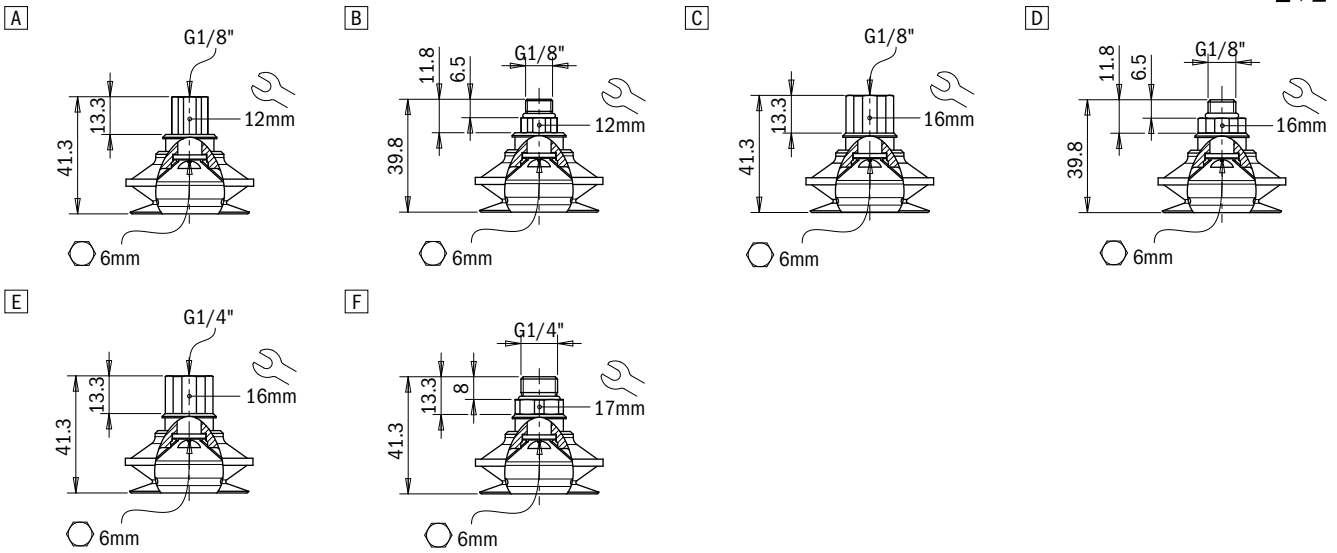

Identification codes

Drawing	Alphanumeric code	Suction cups	Order code
A	VG.B42E.50	VG.B42 suction cup, EPDM, 50 Shore	2321625
A	VG.B42H.60	VG.B42 suction cup, HNBR, 60 Shore	2321632

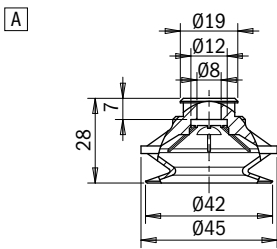

Identification codes

Drawing	Alphanumeric code	Fittings	Order code
A	FT.G18F.E12	G1/8" female fitting, 12 mm hex	2321422
B	FT.G18M.E12	G1/8" male fitting, 12 mm hex	2321424
C	FT.G18F.E16	G1/8" female fitting, 16 mm hex	2321426
D	FT.G18M.E16	G1/8" male fitting, 16 mm hex	2321428
E	FT.G14F.E16	G1/4" female fitting, 16 mm hex	2321430
F	FT.G14M.E17	G1/4" male fitting, 17 mm hex	2321432

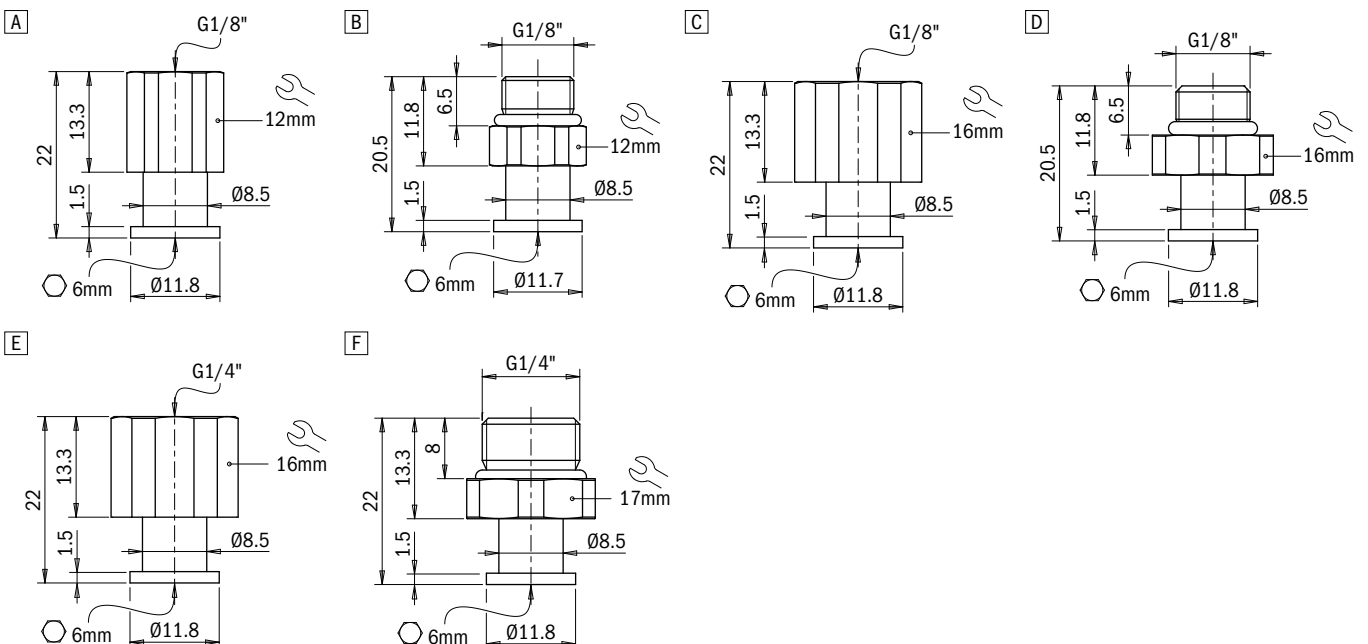

Suction cups / EPDM-HNBR

VG.B53 EPDM-HNBR bellows suction cups

- Suitable for handling plastic parts
- Suitable for objects with flat or slightly curved surfaces
- They enable to compensate for differences in height
- The HNBR version enables to work at high temperatures, whereas silicone or other mixtures may release traces of material. Ideal for applications where contamination of the material must be avoided (PWIS)
- The HNBR compound is robust and wear resistant, suitable for the removal of hot plastic parts from the relevant moulds

Application example

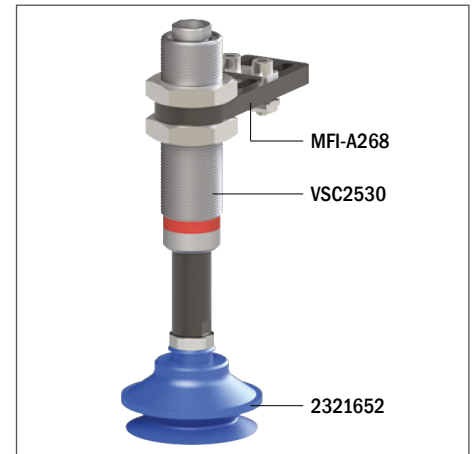

Technical data

Material	Lifting force [N] perpendicular to the surface, at various vacuum levels			Lifting force [N] parallel to the surface, at various vacuum levels			Volume [cm ³]	Min curve radius [mm]	Max vertical movement [mm]	Suction cup weight [g]
	-20 kPa	-60 kPa	-90 kPa	-20 kPa	-60 kPa	-90 kPa				
EPDM 50	32	64.5	90	24.5	51.3	60.5	32	30	19	15.4
HNBR 60	32	64.5	90	24.5	51.3	60.5	32	30	19	15.4

Technical features

Material	Color	Hardness	Temperature range
EPDM	Black	50 Shore	-40 - +212 °F
HNBR	Blue	60 Shore	-13 - +302 °F

Identification codes

Drawing	Alphanumeric code	Suction cups with fitting	Order code
A	VG.B53E.50.G18F.E12	VG.B53 suction cup, EPDM, 50 Shore, G1/8" female, 12 mm hex	2321639
B	VG.B53E.50.G18M.E12	VG.B53 suction cup, EPDM, 50 Shore, G1/8" male, 12 mm hex	2321641
C	VG.B53E.50.G18F.E16	VG.B53 suction cup, EPDM, 50 Shore, G1/8" female, 16 mm hex	2321642
D	VG.B53E.50.G18M.E16	VG.B53 suction cup, EPDM, 50 Shore, G1/8" male, 16 mm hex	2321643
E	VG.B53E.50.G14F.E16	VG.B53 suction cup, EPDM, 50 Shore, G1/4" female, 16 mm hex	2321644
F	VG.B53E.50.G14M.E17	VG.B53 suction cup, EPDM, 50 Shore, G1/4" male, 17 mm hex	2321645
A	VG.B53H.60.G18F.E12	VG.B53 suction cup, HNBR, 60 Shore, G1/8" female, 12 mm hex	2321646
B	VG.B53H.60.G18M.E12	VG.B53 suction cup, HNBR, 60 Shore, G1/8" male, 12 mm hex	2321648
C	VG.B53H.60.G18F.E16	VG.B53 suction cup, HNBR, 60 Shore, G1/8" female, 16 mm hex	2321649
D	VG.B53H.60.G18M.E16	VG.B53 suction cup, HNBR, 60 Shore, G1/8" male, 16 mm hex	2321650
E	VG.B53H.60.G14F.E16	VG.B53 suction cup, HNBR, 60 Shore, G1/4" female, 16 mm hex	2321651
F	VG.B53H.60.G14M.E17	VG.B53 suction cup, HNBR, 60 Shore, G1/4" male, 17 mm hex	2321652

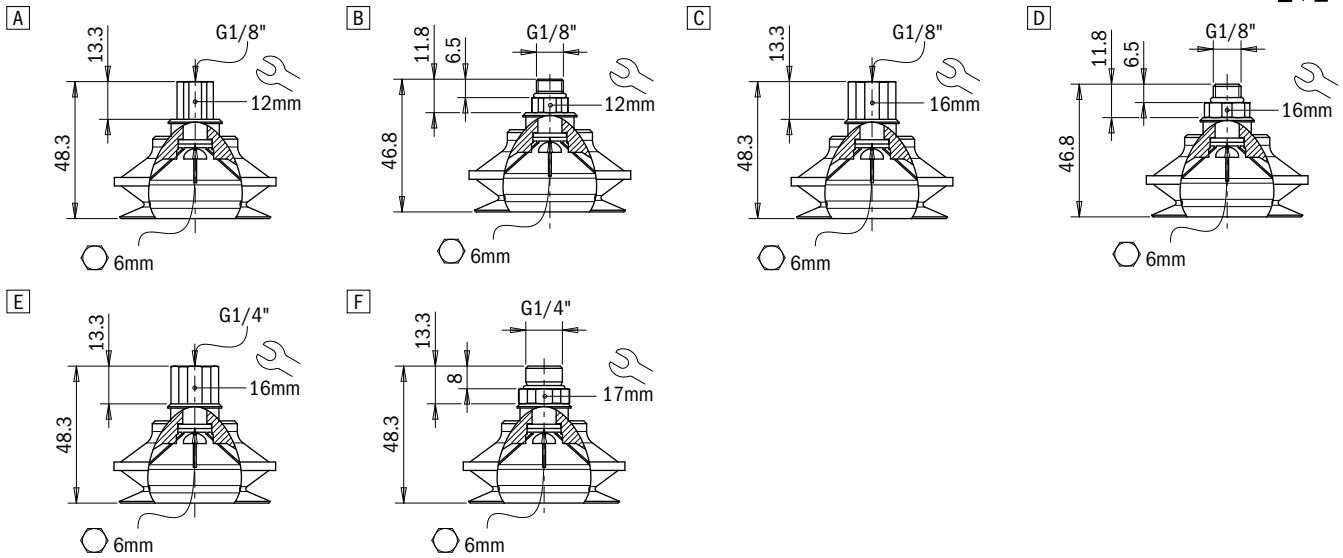

Identification codes

Drawing	Alphanumeric code	Suction cups	Order code
A	VG.B53E.50	VG.B53 suction cup, EPDM, 50 Shore	2321640
A	VG.B53H.60	VG.B53 suction cup, HNBR, 60 Shore	2321647

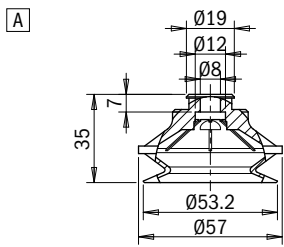

Identification codes

Drawing	Alphanumeric code	Fittings	Order code
A	FT.G18F.E12	G1/8" female fitting, 12 mm hex	2321422
B	FT.G18M.E12	G1/8" male fitting, 12 mm hex	2321424
C	FT.G18F.E16	G1/8" female fitting, 16 mm hex	2321426
D	FT.G18M.E16	G1/8" male fitting, 16 mm hex	2321428
E	FT.G14F.E16	G1/4" female fitting, 16 mm hex	2321430
F	FT.G14M.E17	G1/4" male fitting, 17 mm hex	2321432

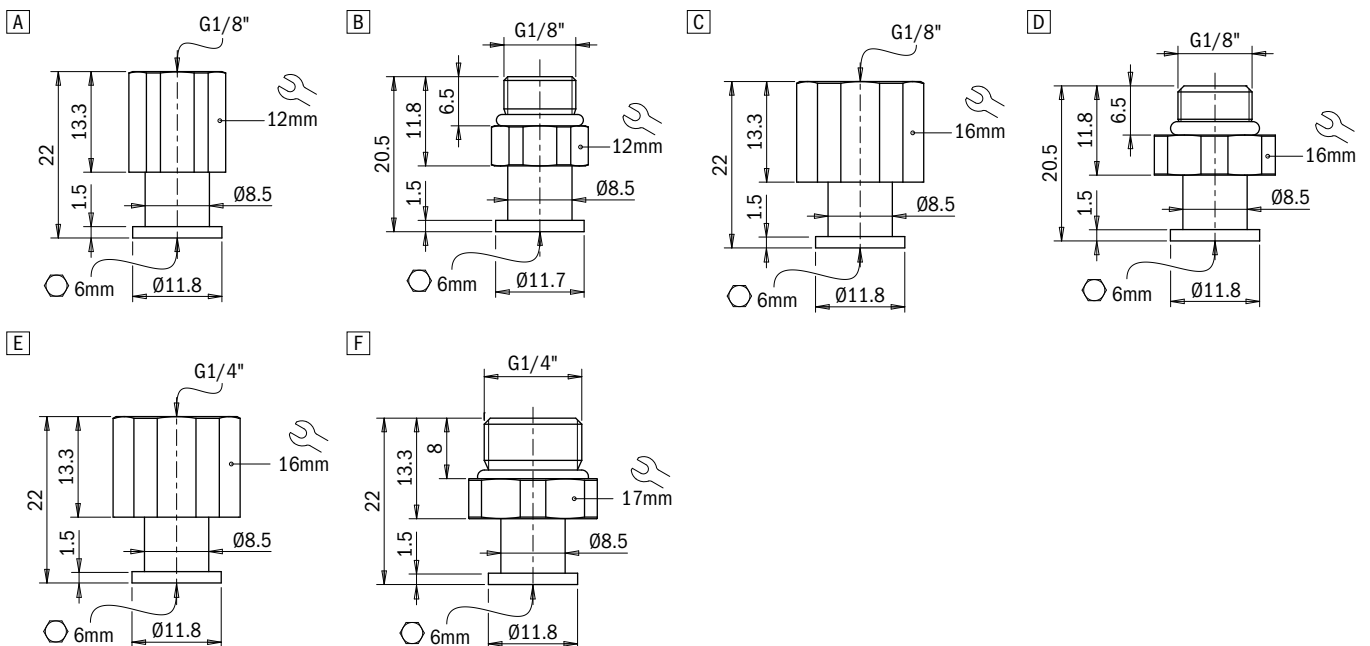

Suction cups / NBR

VG.B77 NBR bellows suction cups

- Ideal for palletisation and depalletisation applications
- Suitable for objects with flat or slightly curved surfaces
- They enable to compensate for differences in height

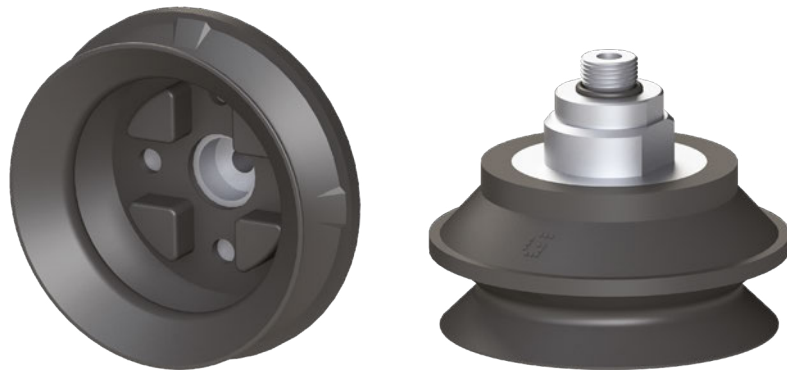

Application example



Technical data

Material	Lifting force [N] perpendicular to the surface, at various vacuum levels			Lifting force [N] parallel to the surface, at various vacuum levels			Volume [cm ³]	Min curve radius [mm]	Max vertical movement [mm]	Suction cup weight [g]
	-20 kPa	-60 kPa	-90 kPa	-20 kPa	-60 kPa	-90 kPa				
NBR 60	78	173	231	66	125	157	110	40	24	35

Technical features

Material	Color	Hardness	Temperature range
NBR	Black	60 Shore	-22 - +212 °F

Identification codes

Drawing	Alphanumeric code	Suction cups with fitting	Order code
A	VG.B77N.60.G14M	VG.B77 suction cup, NBR, 60 Shore, G1/4" male	2322189
B	VG.B77N.60.G14F	VG.B77 suction cup, NBR, 60 Shore, G1/4" female	2322190
C	VG.B77N.60.G38M	VG.B77 suction cup, NBR, 60 Shore, G3/8" male	2322191
D	VG.B77N.60.G38F	VG.B77 suction cup, NBR, 60 Shore, G3/8" female	2322192

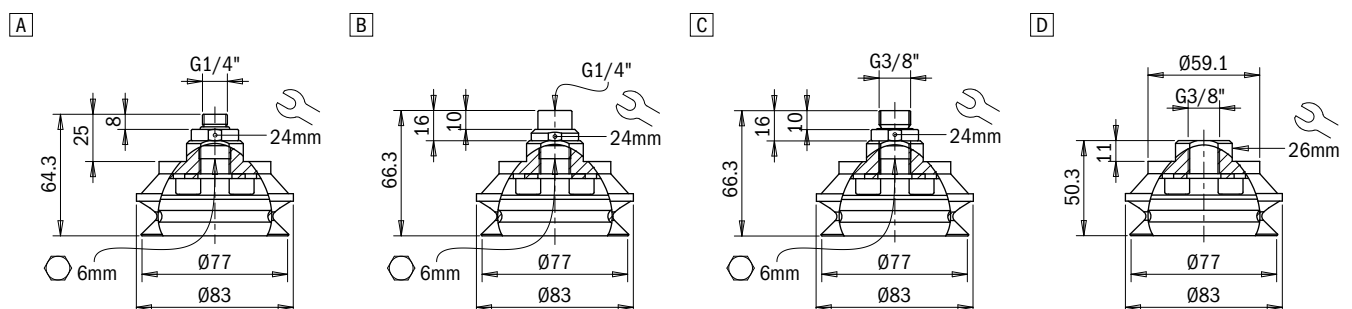

Suction cups / Silicone

VG.CF16 flat suction cups, silicone, with reinforcements

- Ideal for handling plastic parts, dry sheet metal and cardboard
- Suitable for items with flat surfaces
- Suitable for handling items with lifting force parallel to the surface thanks to the reinforcements that increase friction and prevent deformations
- The silicone version enables to work at high and low temperatures

Application example

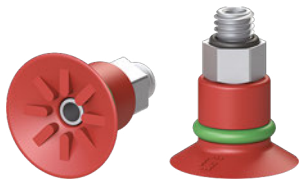
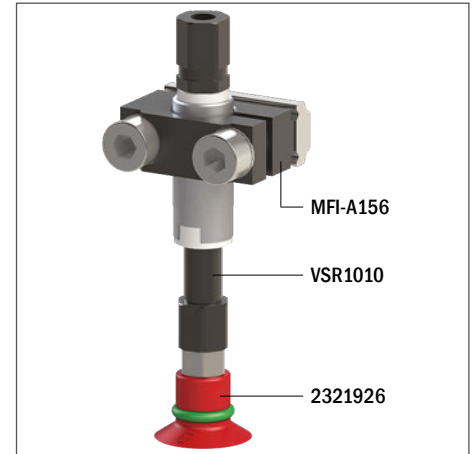

Technical data

Material	Lifting force [N] perpendicular to the surface, at various vacuum levels			Lifting force [N] parallel to the surface, at various vacuum levels			Volume [cm ³]	Min curve radius [mm]	Max vertical movement [mm]	Suction cup weight [g]
	-20 kPa	-60 kPa	-90 kPa	-20 kPa	-60 kPa	-90 kPa				
SIL 50	3.3	8.7	10.1	3.2	6.5	7.6	0.37	13	1	0.7

Technical features

Material	Color	Hardness	Temperature range
Silicone	Red	50 Shore	-94 - +392 °F

Identification codes			
Drawing	Alphanumeric code	Suction cups with fitting	Order code
A	VG.CF16S.50.M5M	VG.CF16 suction cup, silicone, 50 shore, M5 male	2321926

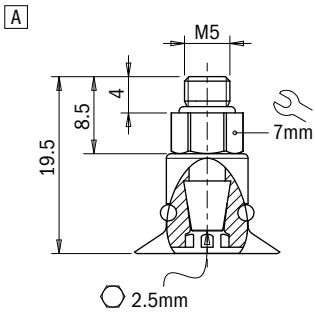

Identification codes			
Drawing	Alphanumeric code	Suction cups	Order code
A	VG.CF16S.50	VG.CF16 suction cup, silicone, 50 Shore	2321927

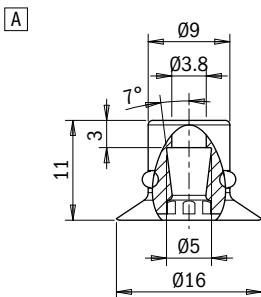

Click for Pricing & Add to Cart



Identification codes			
Drawing	Alphanumeric code	Fittings	Order code
A	FT.M5M	M5 male fitting	1600005

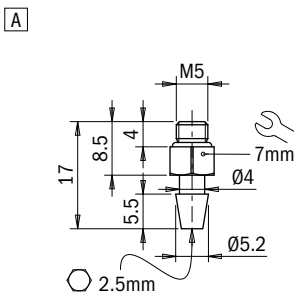

Suction cups / Silicone

VG.CF22 flat suction cups, silicone, with reinforcements

- Ideal for handling plastic parts, dry sheet metal and cardboard
- Suitable for items with flat surfaces
- Suitable for handling items with lifting force parallel to the surface thanks to the reinforcements that increase friction and prevent deformations
- The silicone version enables to work at high and low temperatures

Application example

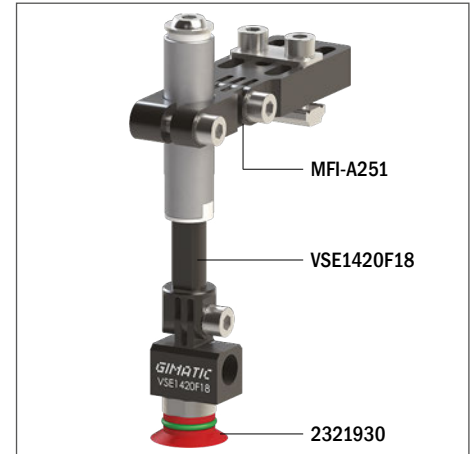

Technical data

Material	Lifting force [N] perpendicular to the surface, at various vacuum levels			Lifting force [N] parallel to the surface, at various vacuum levels			Volume [cm ³]	Min curve radius [mm]	Max vertical movement [mm]	Suction cup weight [g]
	-20 kPa	-60 kPa	-90 kPa	-20 kPa	-60 kPa	-90 kPa				
SIL 50	6.1	13.7	18.7	5.1	8.2	8.5	1	18	1.5	1.1

Technical features

Material	Color	Hardness	Temperature range
Silicone	Red	50 Shore	-94 - +392 °F

Identification codes			
Drawing	Alphanumeric code	Suction cups with fitting	Order code
A	VG.CF22S.50.M5F	VG.CF22 suction cup, silicone, 50 shore, M5 female	2321928
B	VG.CF22S.50.G18M	VG.CF22 suction cup, silicone, 50 Shore, G1/8" male	2321930
C	VG.CF22S.50.G18MF	VG.CF22 suction cup, silicone, 50 Shore, G1/8" male/M5 female	2321931
D	VG.CF22S.50.G18MFV	VG.CF22 suction cup, silicone, 50 Shore, G1/8" male/M5 female with valve	2321932

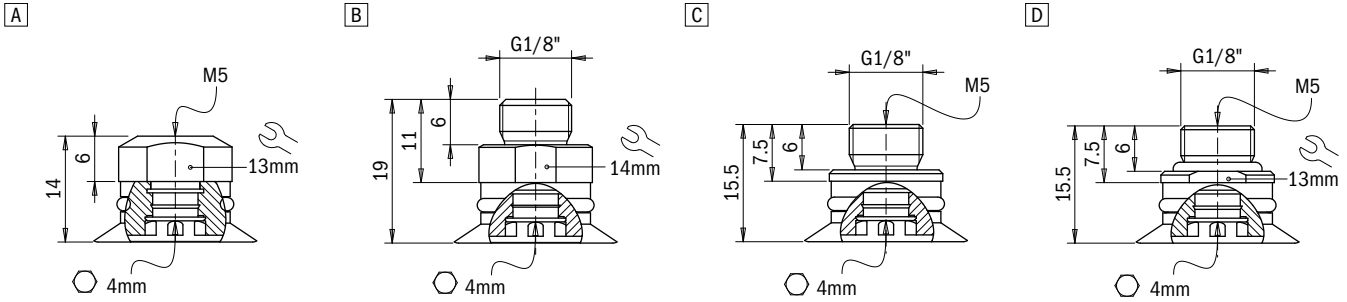

Identification codes			
Drawing	Alphanumeric code	Suction cups	Order code
A	VG.CF22S.50	VG.CF22 suction cup, silicone, 50 Shore	2321929

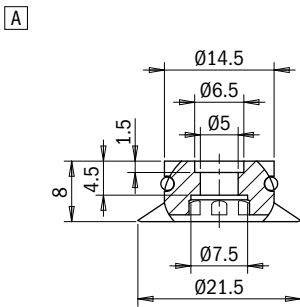

Identification codes			
Drawing	Alphanumeric code	Fittings	Order code
A	FT.M5F	Fitting, M5 Female	1700006
B	FT.G18M.17	G1/8" male fitting	1700018
C	FT.G18M.M5F	Fitting, G1/8" male/ M5 female	1700016
D	FT.G18M.M5F.VF	G1/8" male / M5 female fitting, with valve	1700017

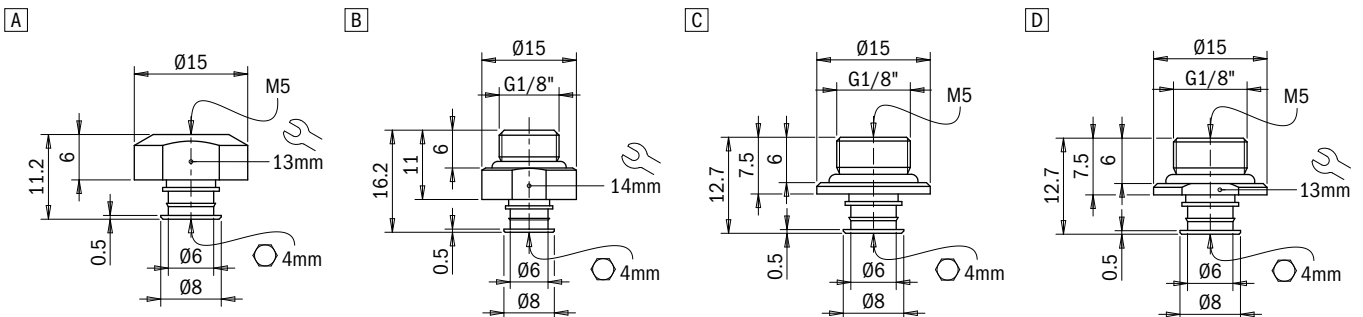

Suction cups / Silicone

VG.CF27 flat suction cups, silicone, with reinforcements

- Ideal for handling plastic parts, dry sheet metal and cardboard
- Suitable for items with flat surfaces
- Suitable for handling items with lifting force parallel to the surface thanks to the reinforcements that increase friction and prevent deformations
- The silicone version enables to work at high and low temperatures

Application example

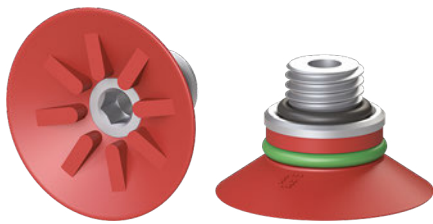
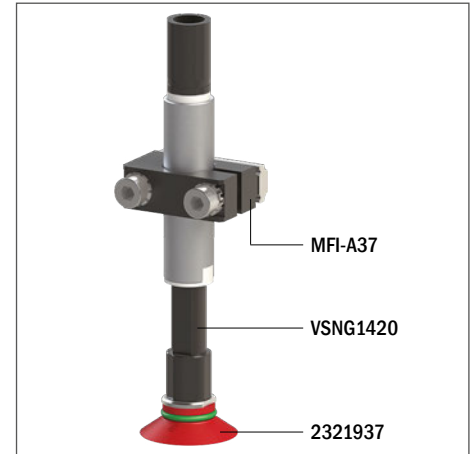

Technical data

Material	Lifting force [N] perpendicular to the surface, at various vacuum levels			Lifting force [N] parallel to the surface, at various vacuum levels			Volume [cm ³]	Min curve radius [mm]	Max vertical movement [mm]	Suction cup weight [g]
	-20 kPa	-60 kPa	-90 kPa	-20 kPa	-60 kPa	-90 kPa				
SIL 50	8.9	21.6	29.1	8.3	9.3	10.2	1.1	22	1.5	1.5

Technical features

Material	Color	Hardness	Temperature range
Silicone	Red	50 Shore	-94 - +392 °F

Identification codes			
Drawing	Alphanumeric code	Suction cups with fitting	Order code
A	VG.CF27S.50.M5F	VG.CF27 suction cup, silicone, 50 Shore, M5 female	2321933
B	VG.CF27S.50.G18M	VG.CF27 suction cup, silicone, 50 Shore, G1/8" male	2321935
C	VG.CF27S.50.G18MF	VG.CF27 suction cup, silicone, 50 Shore, G1/8" male/M5 female	2321936
D	VG.CF27S.50.G18MFV	VG.CF27 suction cup, silicone, 50 Shore, G1/8" male/M5 female with valve	2321937

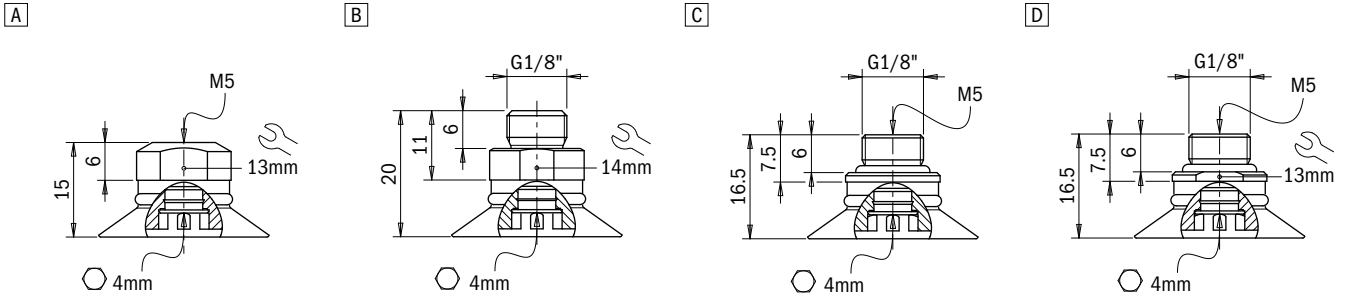

Identification codes			
Drawing	Alphanumeric code	Suction cups	Order code
A	VG.CF27S.50	VG.CF27 suction cup, silicone, 50 Shore	2321934

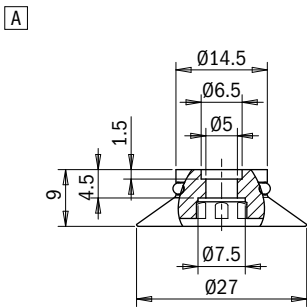

Identification codes			
Drawing	Alphanumeric code	Fittings	Order code
A	FT.M5F	Fitting, M5 female	1700006
B	FT.G18M.17	G1/8" male fitting	1700018
C	FT.G18M.M5F	Fitting, G1/8" Male/ M5 female	1700016
D	FT.G18M.M5F.VF	G1/8" male / M5 female fitting, with valve	1700017

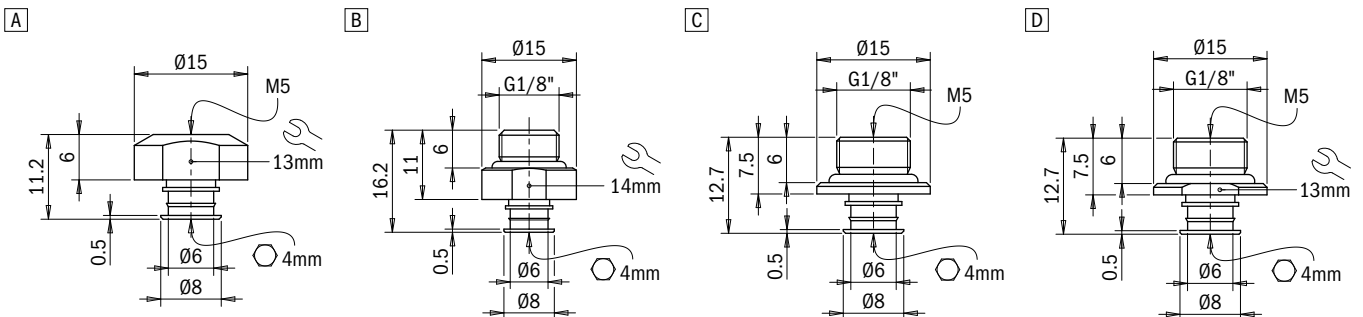

Suction cups / Silicone

VG.CF33 flat suction cups, silicone, with reinforcements

- Ideal for handling plastic parts, dry sheet metal and cardboard
- Suitable for items with flat surfaces
- Suitable for handling items with lifting force parallel to the surface thanks to the reinforcements that increase friction and prevent deformations
- The silicone version enables to work at high and low temperatures

Application example

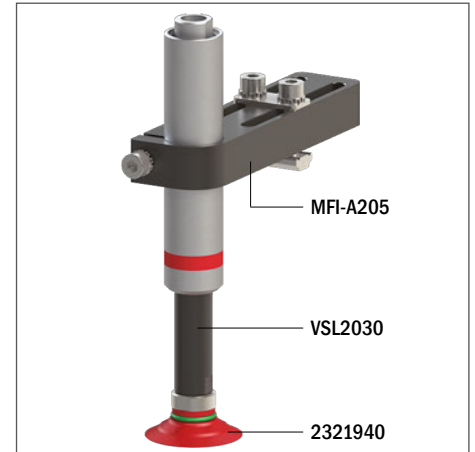

Technical data

Material	Lifting force [N] perpendicular to the surface, at various vacuum levels			Lifting force [N] parallel to the surface, at various vacuum levels			Volume [cm ³]	Min curve radius [mm]	Max vertical movement [mm]	Suction cup weight [g]
	-20 kPa	-60 kPa	-90 kPa	-20 kPa	-60 kPa	-90 kPa				
SIL 50	12.4	32.3	41.5	11	16.2	20.8	2	25	2	2.1

Technical features

Material	Color	Hardness	Temperature range
Silicone	Red	50 Shore	-94 - +392 °F

Identification codes

Drawing	Alphanumeric code	Suction cups with fitting	Order code
A	VG.CF33S.50.M5F	VG.CF33 suction cup, silicone, 50 Shore, M5 female	2321938
B	VG.CF33S.50.G18M	VG.CF33 suction cup, silicone, 50 Shore, G1/8" male	2321940
C	VG.CF33S.50.G18MF	VG.CF33 suction cup, silicone, 50 Shore, G1/8" male/M5 female	2321941
D	VG.CF33S.50.G18MFV	VG.CF33 suction cup, silicone, 50 Shore, G1/8" male/M5 female with valve	2321942

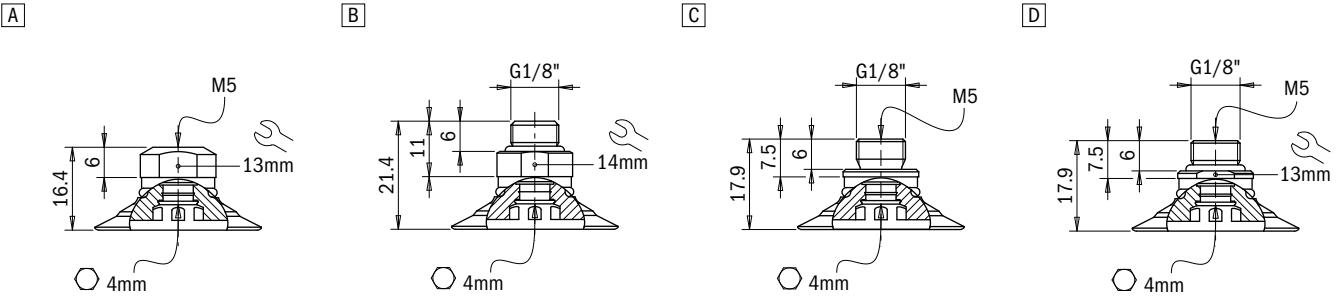

Identification codes

Drawing	Alphanumeric code	Suction cups	Order code
A	VG.CF33S.50	VG.CF33 suction cup, silicone, 50 Shore	2321939

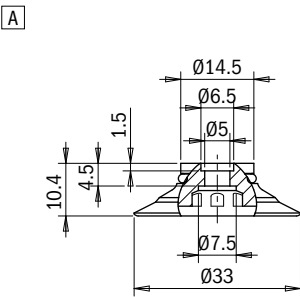

Identification codes

Drawing	Alphanumeric code	Fittings	Order code
A	FT.M5F	Fitting, M5 female	1700006
B	FT.G18M.17	G1/8" male fitting	1700018
C	FT.G18M.M5F	G1/8" male / M5 female fitting	1700016
D	FT.G18M.M5F.VF	G1/8" male / M5 female fitting, with valve	1700017

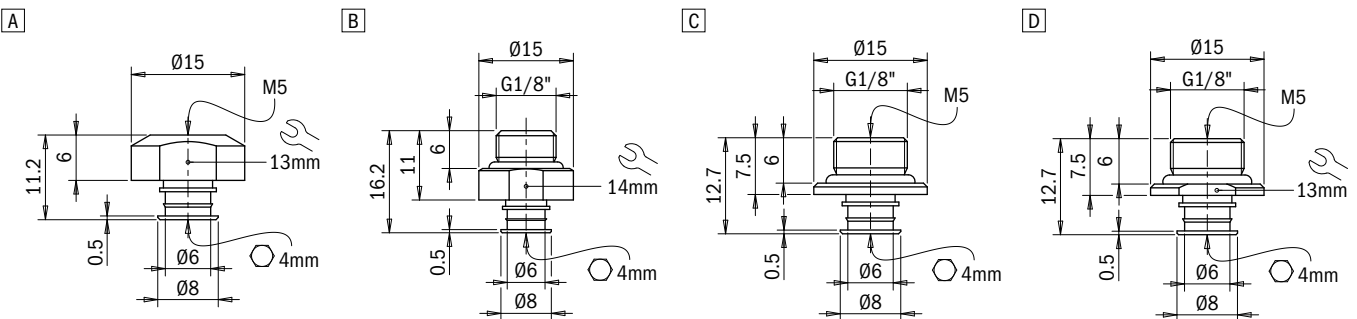

Suction cups / Silicone

VG.CF42 flat suction cups, silicone, with reinforcements

- Ideal for handling plastic parts, dry sheet metal and cardboard
- Suitable for items with flat surfaces
- Suitable for handling items with lifting force parallel to the surface thanks to the reinforcements that increase friction and prevent deformations
- The silicone version enables to work at high and low temperatures

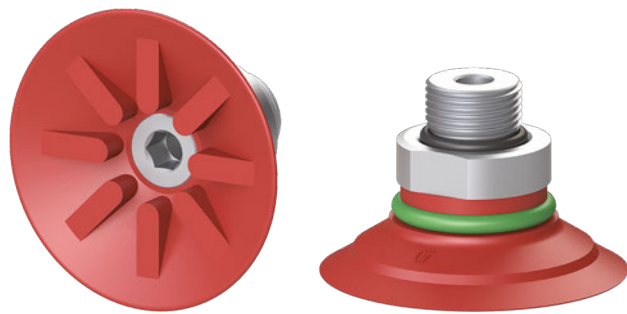

Application example

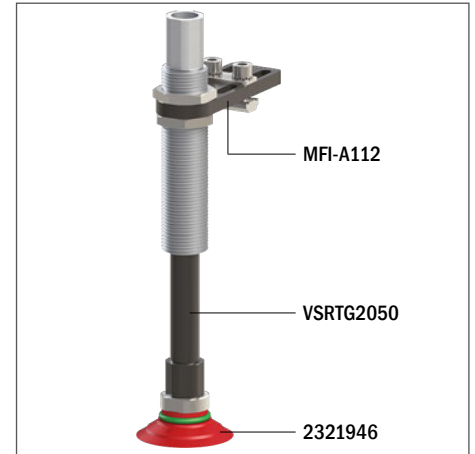

Technical data

Material	Lifting force [N] perpendicular to the surface, at various vacuum levels			Lifting force [N] parallel to the surface, at various vacuum levels			Volume [cm ³]	Min curve radius [mm]	Max vertical movement [mm]	Suction cup weight [g]
	-20 kPa	-60 kPa	-90 kPa	-20 kPa	-60 kPa	-90 kPa				
SIL 50	21.8	52	68	15	24.5	31	4.8	52	1.8	5.2

Technical features

Material	Color	Hardness	Temperature range
Silicone	Red	50 Shore	-94 - +392 °F

Identification codes

Drawing	Alphanumeric code	Suction cups with fitting	Order code
A	VG.CF42S.50.G18F	VG.CF42 suction cup, silicone, 50 Shore, G1/8" female	2321943
B	VG.CF42S.50.G18M	VG.CF42 suction cup, silicone, 50 Shore, G1/8" male	2321945
C	VG.CF42S.50.G14M	VG.CF42 suction cup, silicone, 50 Shore, G1/4" male	2321946
D	VG.CF42S.50.G38M	VG.CF42 suction cup, silicone, 50 Shore, G3/8" male	2321947

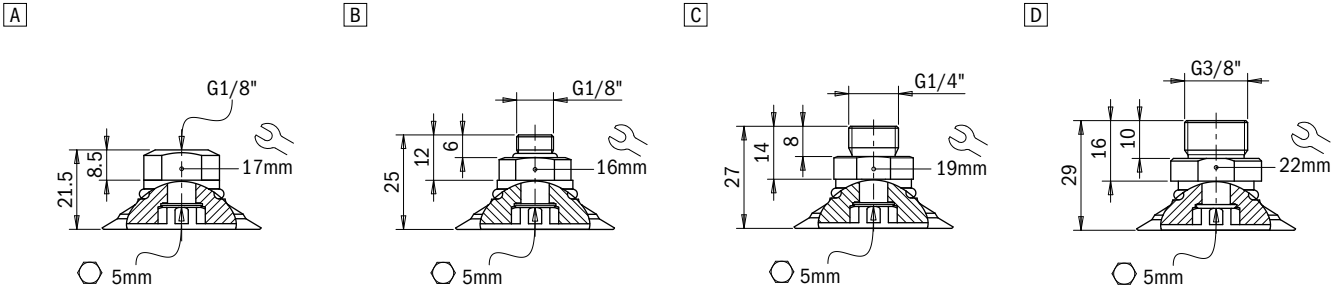

Identification codes

Drawing	Alphanumeric code	Suction cups	Order code
A	VG.CF42S.50	VG.CF42 suction cup, silicone, 50 Shore	2321944

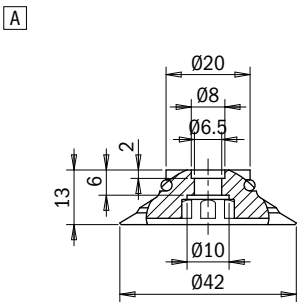

Identification codes

Drawing	Alphanumeric code	Fittings	Order code
A	FT.G18F.18	G1/8" female fitting	1800019
B	FT.G18M.18	G1/8" male fitting	1800018
C	FT.G14M.18	G1/4" male fitting	1800014
D	FT.G38M.18	G3/8" male fitting	1800038

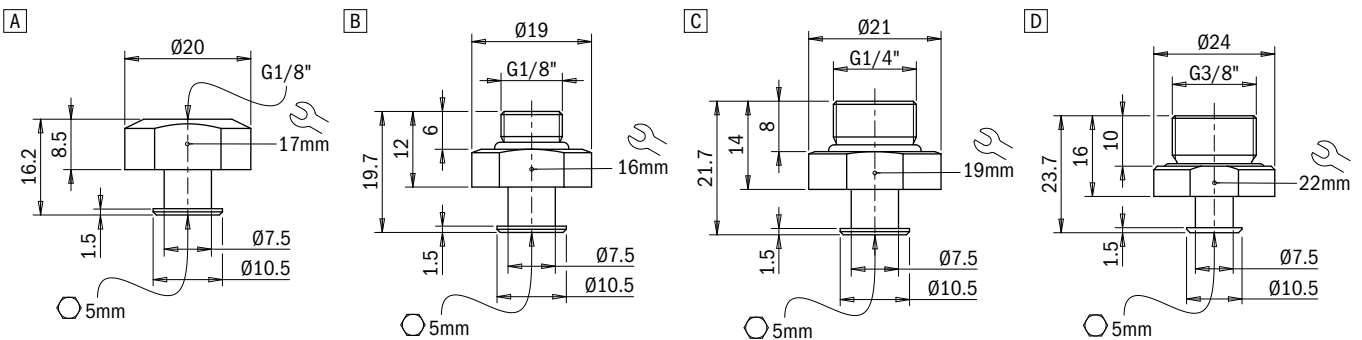

Suction cups / Silicone

VG.CF53 flat suction cups, silicone, with reinforcements

- Ideal for handling plastic parts, dry sheet metal and cardboard
- Suitable for items with flat surfaces
- Suitable for handling items with lifting force parallel to the surface thanks to the reinforcements that increase friction and prevent deformations
- The silicone version enables to work at high and low temperatures

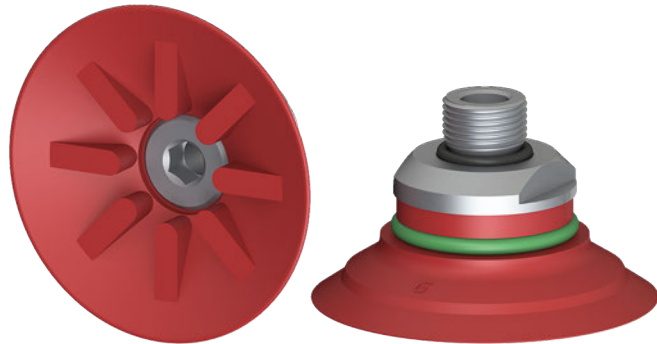

Application example

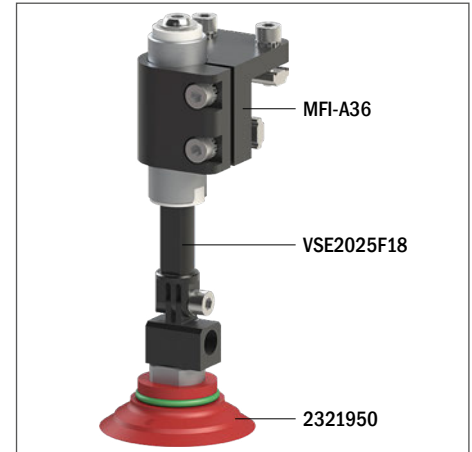

Technical data

Material	Lifting force [N] perpendicular to the surface, at various vacuum levels			Lifting force [N] parallel to the surface, at various vacuum levels			Volume [cm ³]	Min curve radius [mm]	Max vertical movement [mm]	Suction cup weight [g]
	-20 kPa	-60 kPa	-90 kPa	-20 kPa	-60 kPa	-90 kPa				
SIL 50	36.7	72	98	25	42	49	10	55	2.2	10.8

Technical features

Material	Color	Hardness	Temperature range
Silicone	Red	50 Shore	-94 - +392 °F

Identification codes

Drawing	Alphanumeric code	Suction cups with fitting	Order code
A	VG.CF53S.50.G18F	VG.CF53 suction cup, silicone, 50 Shore, G1/8" female	2321948
B	VG.CF53S.50.G18M	VG.CF53 suction cup, silicone, 50 Shore, G1/8" male	2321950
C	VG.CF53S.50.G14M	VG.CF53 suction cup, silicone, 50 Shore, G1/4" male	2321951
D	VG.CF53S.50.G38M	VG.CF53 suction cup, silicone, 50 Shore, G3/8" male	2321952

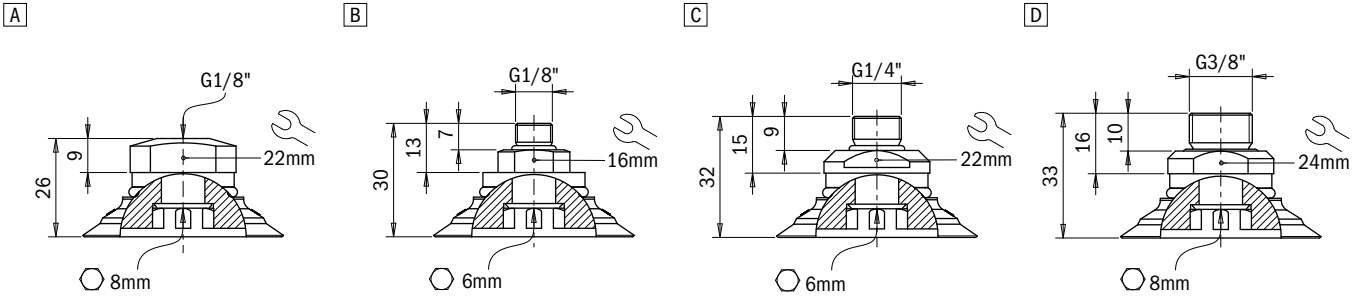

Identification codes

Drawing	Alphanumeric code	Suction cups	Order code
A	VG.CF53S.50	VG.CF53 suction cup, silicone, 50 Shore	2321949

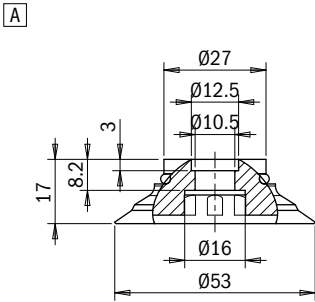

Identification codes

Drawing	Alphanumeric code	Fittings	Order code
A	FT.G18F.19	G1/8" female fitting	1900019
B	FT.G18M.19	G1/8" male fitting	1900018
C	FT.G14M.19	G1/4" male fitting	1900014
D	FT.G38M.198	G3/8" male fitting	1900038

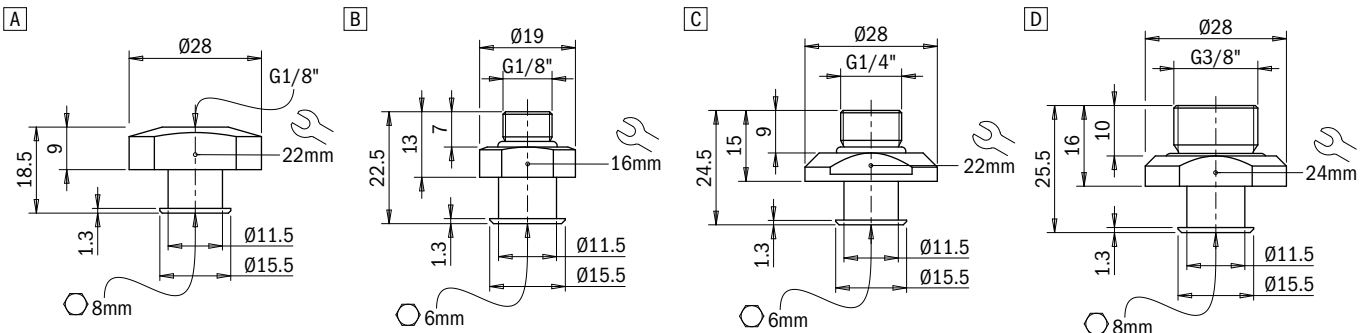

Suction cups / Silicone

VG.CF77 flat suction cups, silicone, with reinforcements

- Ideal for handling plastic parts, dry sheet metal and cardboard
- Suitable for items with flat surfaces
- Suitable for handling items with lifting force parallel to the surface thanks to the reinforcements that increase friction and prevent deformations
- The silicone version enables to work at high and low temperatures

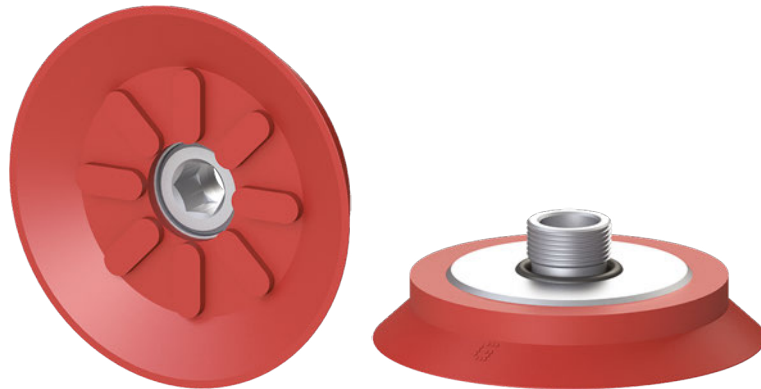

Application example

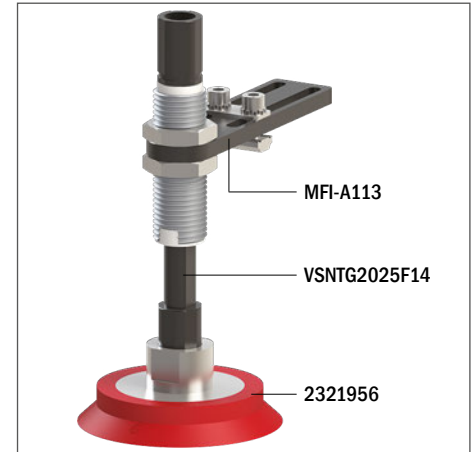

Technical data

Material	Lifting force [N] perpendicular to the surface, at various vacuum levels			Lifting force [N] parallel to the surface, at various vacuum levels			Volume [cm ³]	Min curve radius [mm]	Max vertical movement [mm]	Suction cup weight [g]
	-20 kPa	-60 kPa	-90 kPa	-20 kPa	-60 kPa	-90 kPa				
SIL 50	90	215	290	60	118	145	20	150	3	31.3

Technical features

Material	Color	Hardness	Temperature range
Silicone	Red	50 Shore	-94 - +392 °F

Identification codes

Drawing	Alphanumeric code	Suction cups with fitting	Order code
A	VG.CF77S.50.G18F	VG.CF77 suction cup, silicone, 50 Shore, G1/8" female	2321953
B	VG.CF77S.50.G38F	VG.CF77 suction cup, silicone, 50 Shore, G3/8" female	2321955
C	VG.CF77S.50.G14M	VG.CF77 suction cup, silicone, 50 Shore, G1/4" male	2321956
D	VG.CF77S.50.G38M	VG.CF77 suction cup, silicone, 50 Shore, G3/8" male	2321957

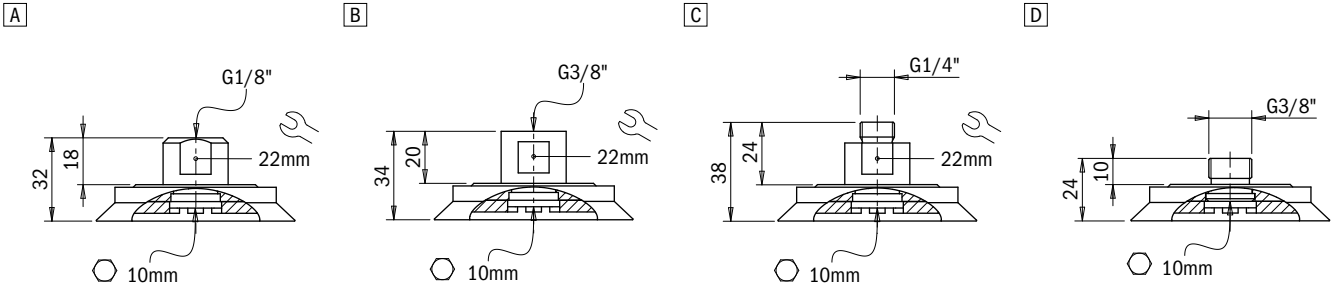

Identification codes

Drawing	Alphanumeric code	Suction cups	Order code
A	VG.CF77S.50	VG.CF77 suction cup, silicone, 50 Shore	2321954

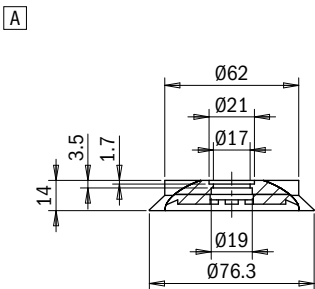

Click for Pricing & Add to Cart



Identification codes

Drawing	Alphanumeric code	Fittings	Order code
A	FT.G18F.16	G1/8" female fitting	1600008
B	FT.G38F	G3/8" female fitting	1600009
C	FT.G14M.16	G1/4" male fitting	1600010
D	FT.G38M.199	G3/8" male fitting	1900039

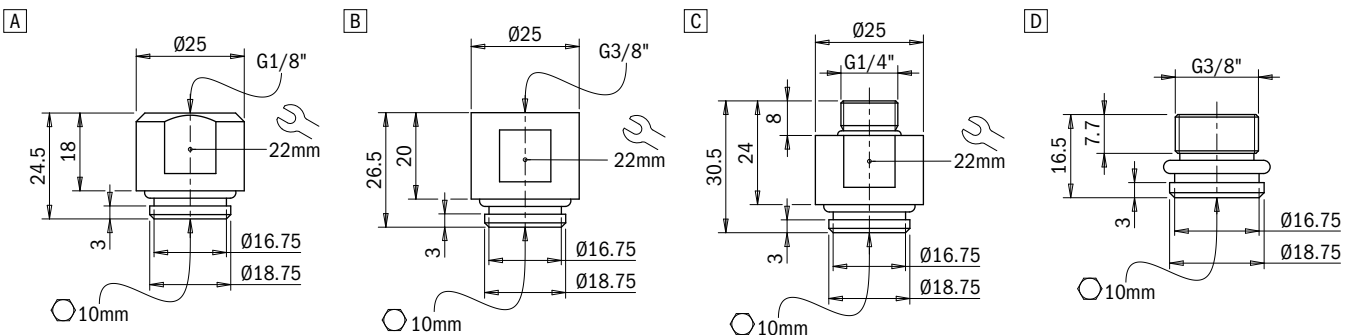

Suction cups / Silicone

VG.CF112 flat suction cups, silicone, with reinforcements

- Ideal for handling plastic parts, dry sheet metal and cardboard
- Suitable for items with flat surfaces
- Suitable for handling items with lifting force parallel to the surface thanks to the reinforcements that increase friction and prevent deformations
- The silicone version enables to work at high and low temperatures



Application example

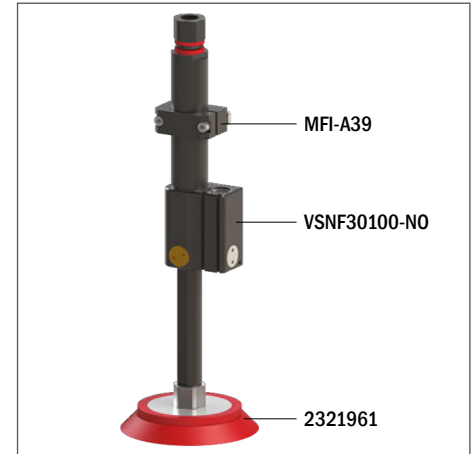

Technical data

Material	Lifting force [N] perpendicular to the surface, at various vacuum levels			Lifting force [N] parallel to the surface, at various vacuum levels			Volume [cm ³]	Min curve radius [mm]	Max vertical movement [mm]	Suction cup weight [g]
	-20 kPa	-60 kPa	-90 kPa	-20 kPa	-60 kPa	-90 kPa				
SIL 50	160	465	570	145	259	310	70	250	4	80.2

Technical features

Material	Color	Hardness	Temperature range
Silicone	Red	50 Shore	-94 - +392 °F

Identification codes

Drawing	Alphanumeric code	Suction cups with fitting	Order code
A	VG.CF112S.50.G38F	VG.CF112 suction cup, silicone, 50 Shore, G3/8" female	2321958
B	VG.CF112S.50.G14M	VG.CF112 suction cup, silicone, 50 Shore, G1/4" male	2321960
C	VG.CF112S.50.G38M	VG.CF112 suction cup, silicone, 50 Shore, G3/8" male	2321961
D	VG.CF112S.50.G12M	VG.CF112 suction cup, silicone, 50 Shore, G1/2" male	2321962

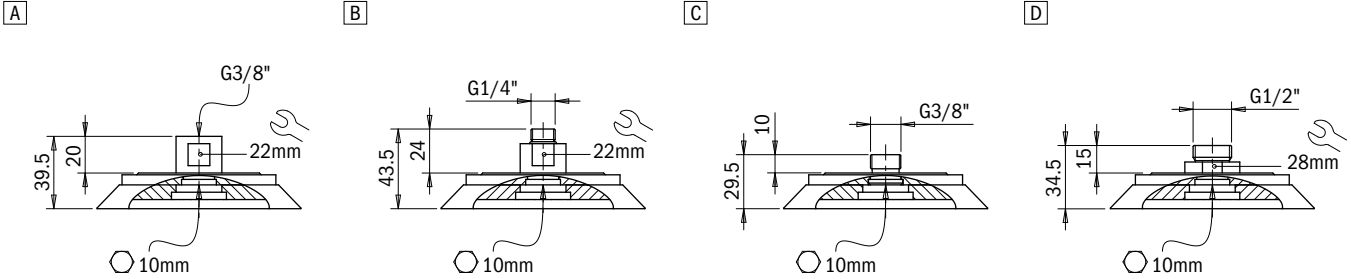

Identification codes

Drawing	Alphanumeric code	Suction cups	Order code
A	VG.CF112S.50	VG.CF112 suction cup, silicone, 50 Shore	2321959

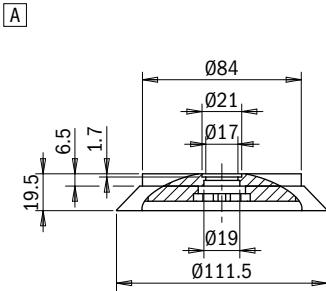

Identification codes

Drawing	Alphanumeric code	Fittings	Order code
A	FT.G38F	G3/8" female fitting	1600009
B	FT.G14M.16	G1/4" male fitting	1600010
C	FT.G38M.199	G3/8" male fitting	1900039
D	FT.G12M.16	G1/2" male fitting	1600015

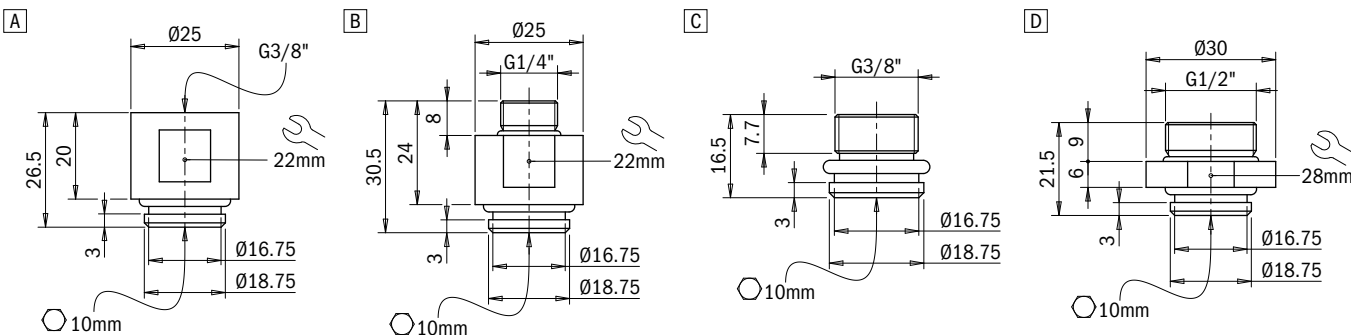

Suction cups / Silicone

VG.CF152 flat suction cups, silicone, with reinforcements

- Ideal for handling plastic parts, dry sheet metal and cardboard
- Suitable for items with flat surfaces
- Suitable for handling items with lifting force parallel to the surface thanks to the reinforcements that increase friction and prevent deformations
- The silicone version enables to work at high and low temperatures

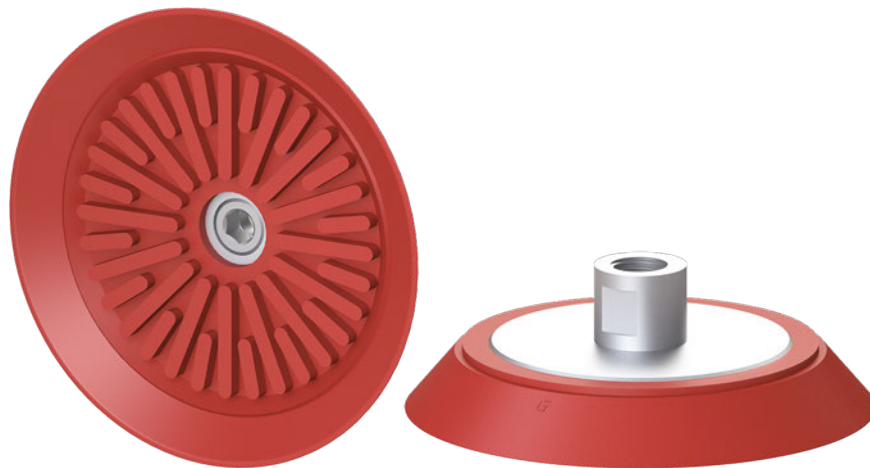

Application example



Technical data

Material	Lifting force [N] perpendicular to the surface, at various vacuum levels			Lifting force [N] parallel to the surface, at various vacuum levels			Volume [cm ³]	Min curve radius [mm]	Max vertical movement [mm]	Suction cup weight [g]
	-20 kPa	-60 kPa	-90 kPa	-20 kPa	-60 kPa	-90 kPa				
SIL 50	310	900	1195	245	620	815	160	500	6	178

Technical features

Material	Color	Hardness	Temperature range
Silicone	Red	50 Shore	-94 - +392 °F

Identification codes

Drawing	Alphanumeric code	Suction cups with fitting	Order code
A	VG.CF152S.50.G38F	VG.CF152 suction cup, silicone, 50 Shore, G3/8" female	2321963
B	VG.CF152S.50.G14M	VG.CF152 suction cup, silicone, 50 Shore, G1/4" male	2321965
C	VG.CF152S.50.G38M	VG.CF152 suction cup, silicone, 50 Shore, G3/8" male	2321966
D	VG.CF152S.50.G12F	VG.CF152 suction cup, silicone, 50 Shore, G1/2" female	2321967

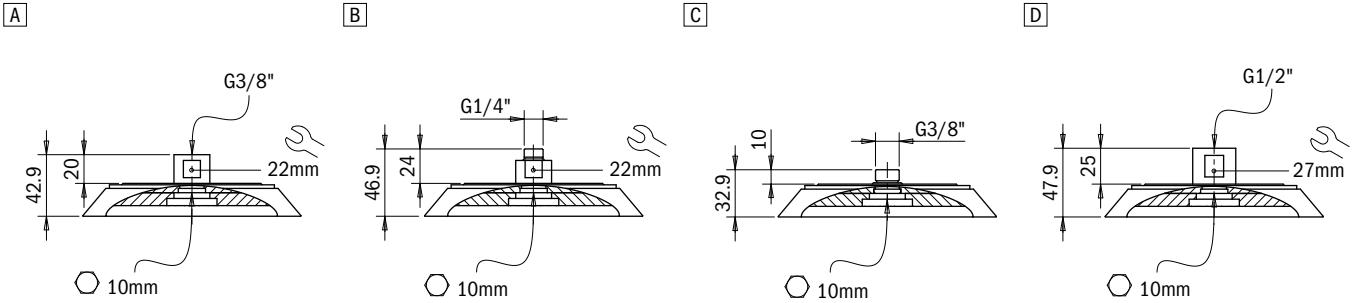

Identification codes

Drawing	Alphanumeric code	Suction cups	Order code
A	VG.CF152S.50	VG.CF152 suction cup, silicone, 50 Shore	2321964

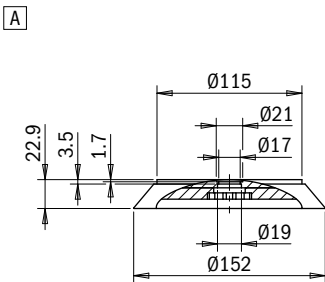

Identification codes

Drawing	Alphanumeric code	Fittings	Order code
A	FT.G38F	G3/8" female fitting	1600009
B	FT.G14M.16	G1/4" male fitting	1600010
C	FT.G38M.199	G3/8" male fitting	1900039
D	FT.G12F	G1/2" female fitting	1600019

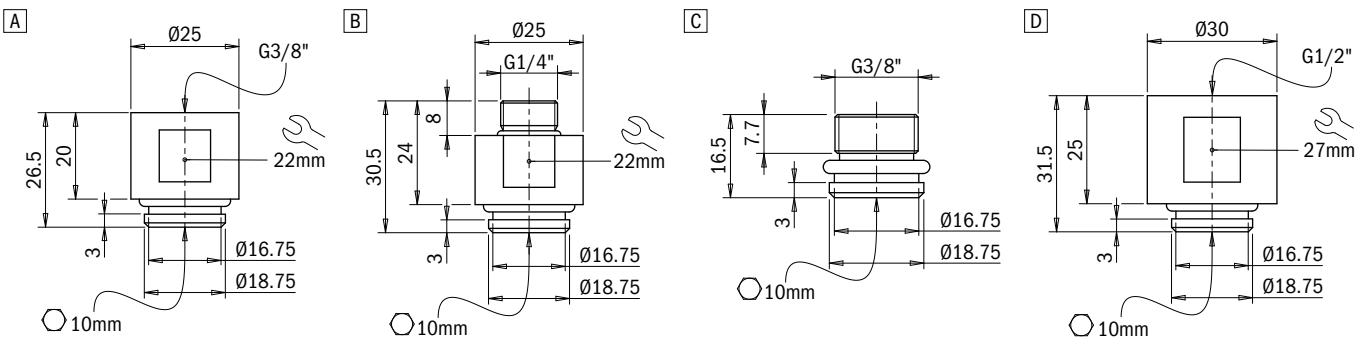

Suction cups / NBR-HNBR

VG.CF16 flat suction cups, NBR-HNBR, with reinforcements

- Ideal for handling plastic parts and dry sheet metal
- Suitable for items with flat surfaces
- Suitable for handling items with lifting force parallel to the surface thanks to the reinforcements that increase friction and prevent deformations
- The HNBR version enables to work at high temperatures, whereas silicone or other mixtures may release traces of material
- The HNBR compound is robust and wear resistant, suitable for the removal of hot plastic parts from the relevant moulds
- HNBR and NBR compounds are ideal for applications where contamination of the material must be avoided (PWIS)

Application example

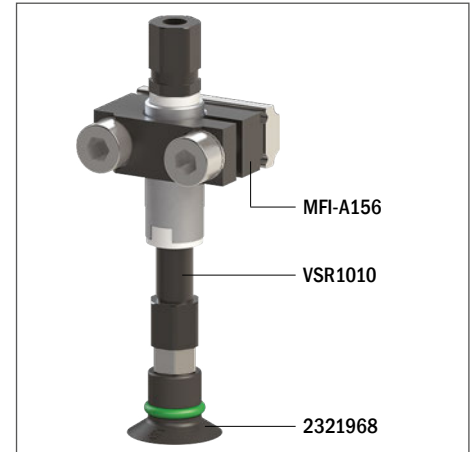

Technical data

Material	Lifting force [N] perpendicular to the surface, at various vacuum levels			Lifting force [N] parallel to the surface, at various vacuum levels			Volume [cm ³]	Min curve radius [mm]	Max vertical movement [mm]	Suction cup weight [g]
	-20 kPa	-60 kPa	-90 kPa	-20 kPa	-60 kPa	-90 kPa				
NBR 60	3.3	8.7	10.1	3.2	6.5	7.6	0.37	13	1	0.8
HNBR 60	3.3	8.7	10.1	3.2	6.5	7.6	0.37	13	1	0.8

Technical features

Material	Color	Hardness	Temperature range
NBR	Black	60 Shore	-22 - +212 °F
HNBR	Blue	60 Shore	-13 - +302 °F

Identification codes

Drawing	Alphanumeric code	Suction cups with fitting	Order code
A	VG.CF16N.60.M5M	VG.CF16 suction cup, NBR, 60 Shore, M5 male	2321968
A	VG.CF16H.60.M5M	VG.CF16 suction cup, HNBR, 60 Shore, M5 male	2322010

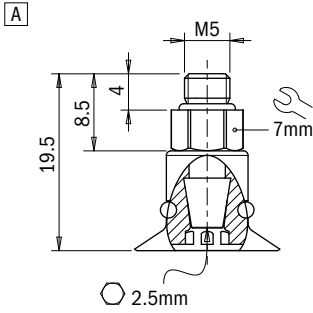

Identification codes

Drawing	Alphanumeric code	Suction cups	Order code
A	VG.CF16N.60	VG.CF16 suction cup, NBR, 60 Shore	2321969
A	VG.CF16H.60	VG.CF16 suction cup, HNBR, 60 Shore	2322011

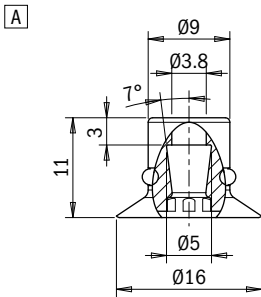

Identification codes

Drawing	Alphanumeric code	Fittings	Order code
A	FT.M5M	M5 male fitting	1600005

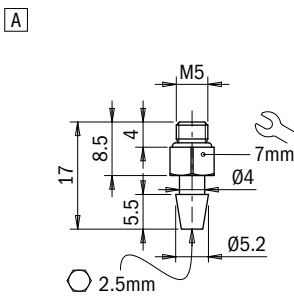

Suction cups / NBR-HNBR

VG.CF22 flat suction cups, NBR-HNBR, with reinforcements

- Ideal for handling plastic parts and dry sheet metal
- Suitable for items with flat surfaces
- Suitable for handling items with lifting force parallel to the surface thanks to the reinforcements that increase friction and prevent deformations
- The HNBR version enables to work at high temperatures, whereas silicone or other mixtures may release traces of material
- The HNBR compound is robust and wear resistant, suitable for the removal of hot plastic parts from the relevant moulds
- HNBR and NBR compounds are ideal for applications where contamination of the material must be avoided (PWIS)

Application example

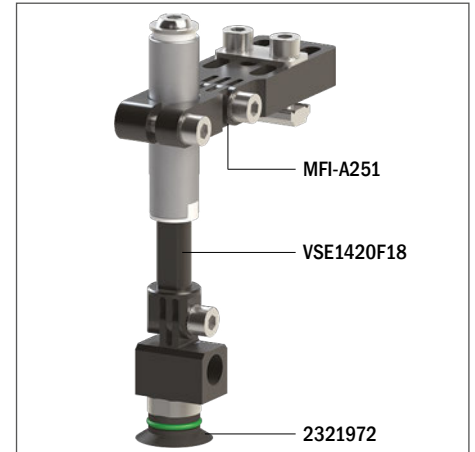

Technical data

Material	Lifting force [N] perpendicular to the surface, at various vacuum levels			Lifting force [N] parallel to the surface, at various vacuum levels			Volume [cm ³]	Min curve radius [mm]	Max vertical movement [mm]	Suction cup weight [g]
	-20 kPa	-60 kPa	-90 kPa	-20 kPa	-60 kPa	-90 kPa				
NBR 60	6.1	13.7	18.7	5.1	8.2	8.5	1	18	1.5	1.3
HNBR 60	6.1	13.7	18.7	5.1	8.2	8.5	1	18	1.5	1.1

Technical features

Material	Color	Hardness	Temperature range
NBR	Black	60 Shore	-22 - +212 °F
HNBR	Blue	60 Shore	-13 - +302 °F

Identification codes			
Drawing	Alphanumeric code	Suction cups with fitting	Order code
A	VG.CF22N.60.M5F	VG.CF22 suction cup, NBR, 60 Shore, M5 female	2321970
B	VG.CF22N.60.G18M	VG.CF22 suction cup, NBR, 60 Shore, G1/8" male	2321972
C	VG.CF22N.60.G18MF	VG.CF22 suction cup, NBR, 60 Shore, G1/8" male/M5 female	2321973
D	VG.CF22N.60.G18MFV	VG.CF22 suction cup, NBR, 60 Shore, G1/8" male/M5 female with valve	2321974
A	VG.CF22H.60.M5F	VG.CF22 suction cup, HNBR, 60 Shore, M5 female	2322012
B	VG.CF22H.60.G18M	VG.CF22 suction cup, HNBR, 60 Shore, G1/8" male	2322014
C	VG.CF22H.60.G18MF	VG.CF22 suction cup, HNBR, 60 Shore, G1/8" male/M5 female	2322015
D	VG.CF22H.60.G18MFV	VG.CF22 suction cup, HNBR, 60 Shore, G1/8" male/M5 female with valve	2322016

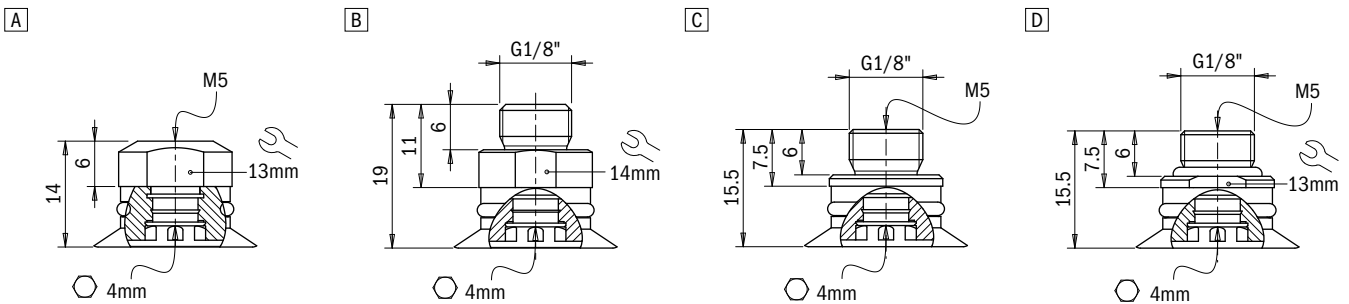

Identification codes			
Drawing	Alphanumeric code	Suction cups	Order code
A	VG.CF22N.60	VG.CF22 suction cup, NBR, 60 Shore	2321971
A	VG.CF22H.60	VG.CF22 suction cup, HNBR, 60 Shore	2322013

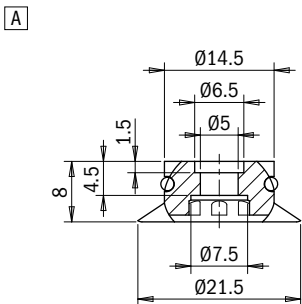

Identification codes			
Drawing	Alphanumeric code	Fittings	Order code
A	FT.M5F	Fitting, M5 female	1700006
B	FT.G18M.17	G1/8" male fitting	1700018
C	FT.G18M.M5F	G1/8" male / M5 female fitting	1700016
D	FT.G18M.M5F.VF	G1/8" male / M5 female fitting, with valve	1700017

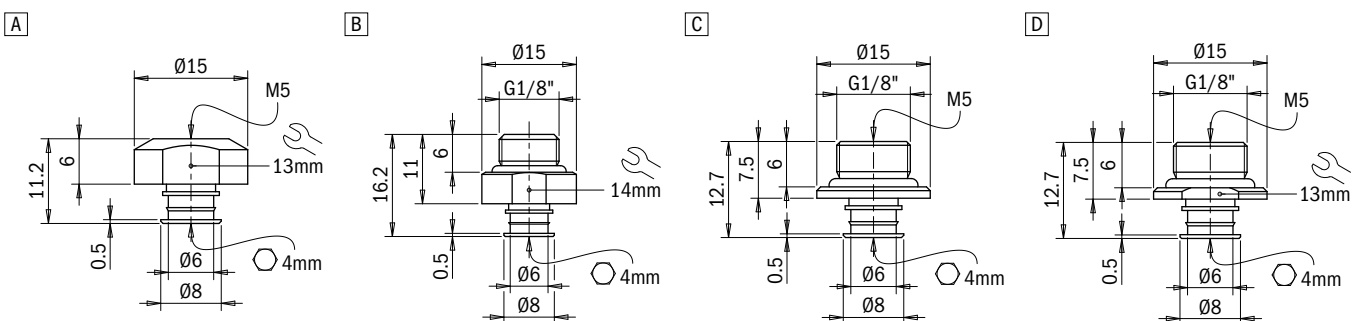

Suction cups / NBR-HNBR

VG.CF27 flat suction cups, NBR-HNBR, with reinforcements

- Ideal for handling plastic parts and dry sheet metal
- Suitable for items with flat surfaces
- Suitable for handling items with lifting force parallel to the surface thanks to the reinforcements that increase friction and prevent deformations
- The HNBR version enables to work at high temperatures, whereas silicone or other mixtures may release traces of material
- The HNBR compound is robust and wear resistant, suitable for the removal of hot plastic parts from the relevant moulds
- HNBR and NBR compounds are ideal for applications where contamination of the material must be avoided (PWIS)

Application example

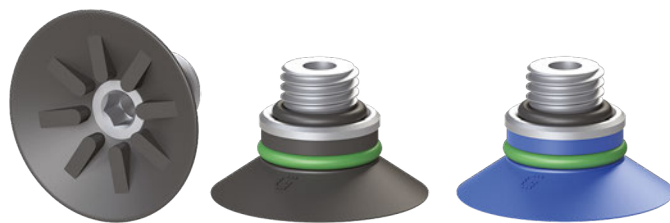
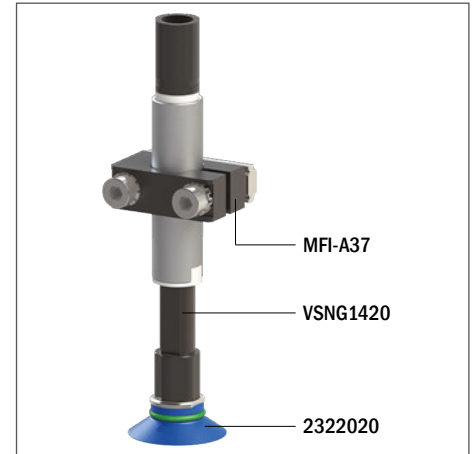

Technical data

Material	Lifting force [N] perpendicular to the surface, at various vacuum levels			Lifting force [N] parallel to the surface, at various vacuum levels			Volume [cm ³]	Min curve radius [mm]	Max vertical movement [mm]	Suction cup weight [g]
	-20 kPa	-60 kPa	-90 kPa	-20 kPa	-60 kPa	-90 kPa				
NBR 60	8.9	21.6	29.1	8.3	9.3	10.2	1.1	22	1.5	1.8
HNBR 60	8.9	21.6	29.1	8.3	9.3	10.2	1.1	22	1.5	1.5

Technical features

Material	Color	Hardness	Temperature range
NBR	Black	60 Shore	-22 - +212 °F
HNBR	Blue	60 Shore	-13 - +302 °F

Identification codes			
Drawing	Alphanumeric code	Suction cups with fitting	Order code
A	VG.CF27N.60.M5F	VG.CF27 suction cup, NBR, 60 Shore, M5 female	2321975
B	VG.CF27N.60.G18M	VG.CF27 suction cup, NBR, 60 Shore, G1/8" male	2321977
C	VG.CF27N.60.G18MF	VG.CF27 suction cup, NBR, 60 Shore, G1/8" male/M5 female	2321978
D	VG.CF27N.60.G18MFV	VG.CF27 suction cup, NBR, 60 Shore, G1/8" male/M5 female with valve	2321979
A	VG.CF27H.60.M5F	VG.CF27 suction cup, HNBR, 60 Shore, M5 female	2322017
B	VG.CF27H.60.G18M	VG.CF27 suction cup, HNBR, 60 Shore, G1/8" male	2322019
C	VG.CF27H.60.G18MF	VG.CF27 suction cup, HNBR, 60 Shore, G1/8" male/M5 female	2322020
D	VG.CF27H.60.G18MFV	VG.CF27 suction cup, HNBR, 60 Shore, G1/8" male/M5 female with valve	2322021

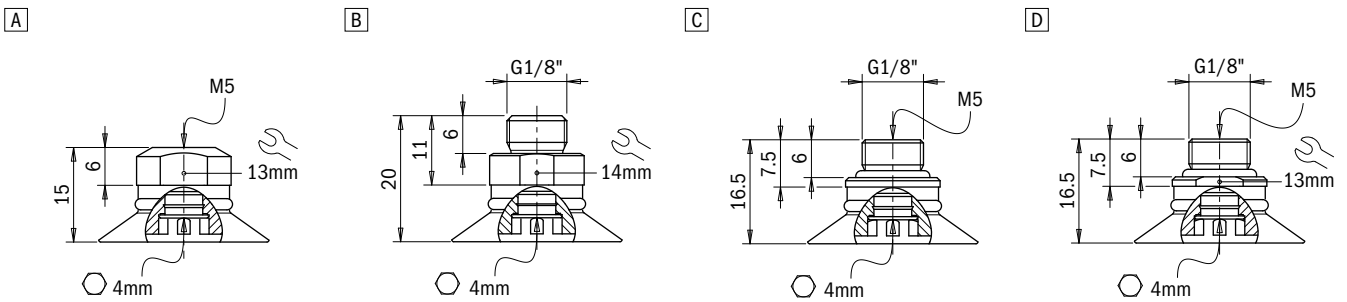

Identification codes			
Drawing	Alphanumeric code	Suction cups	Order code
A	VG.CF27N.60	VG.CF27 suction cup, NBR, 60 Shore	2321976
A	VG.CF27H.60	VG.CF27 suction cup, HNBR, 60 Shore	2322018

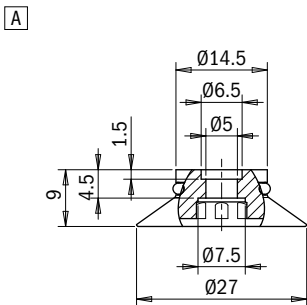

Click for Pricing & Add to Cart

Identification codes			
Drawing	Alphanumeric code	Fittings	Order code
A	FT.M5F	Fitting, M5 female	1700006
B	FT.G18M.17	G1/8" male fitting	1700018
C	FT.G18M.M5F	G1/8" male / M5 female fitting	1700016
D	FT.G18M.M5F.VF	G1/8" male / M5 female fitting, with valve	1700017

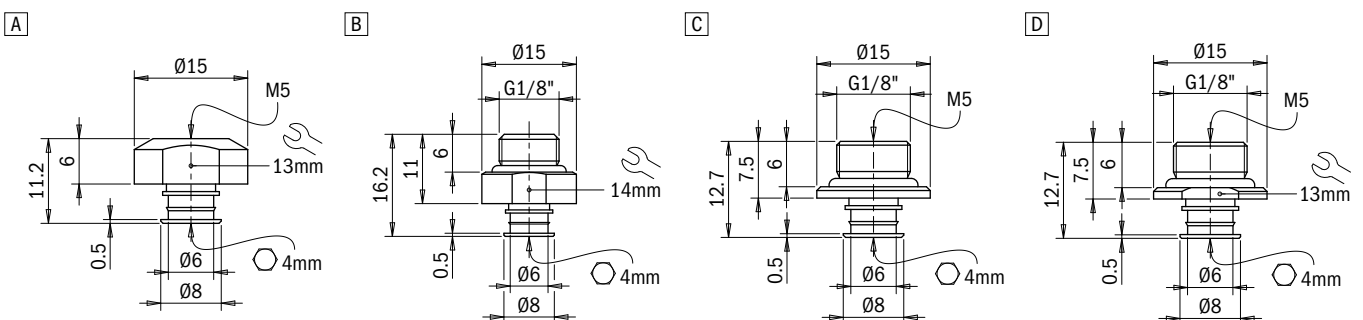

Suction cups / NBR-HNBR

VG.CF33 flat suction cups, NBR-HNBR, with reinforcements

- Ideal for handling plastic parts and dry sheet metal
- Suitable for items with flat surfaces
- Suitable for handling items with lifting force parallel to the surface thanks to the reinforcements that increase friction and prevent deformations
- The HNBR version enables to work at high temperatures, whereas silicone or other mixtures may release traces of material
- The HNBR compound is robust and wear resistant, suitable for the removal of hot plastic parts from the relevant moulds
- HNBR and NBR compounds are ideal for applications where contamination of the material must be avoided (PWIS)

Application example

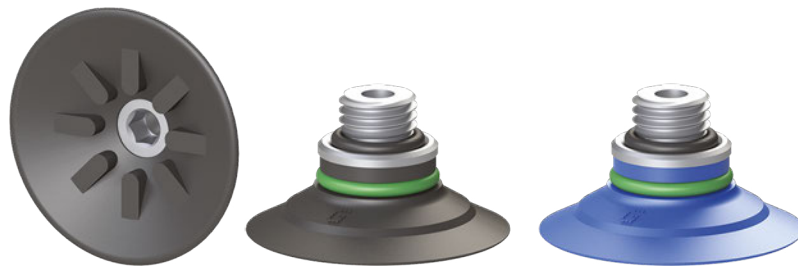
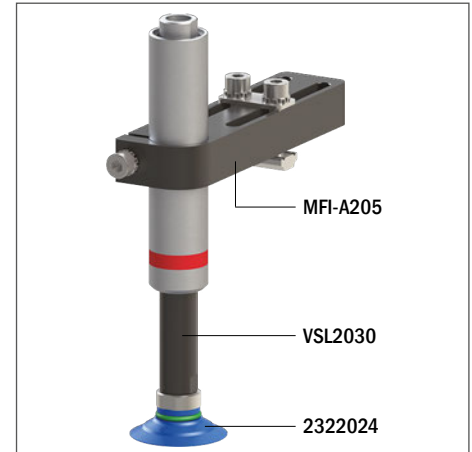

Technical data

Material	Lifting force [N] perpendicular to the surface, at various vacuum levels			Lifting force [N] parallel to the surface, at various vacuum levels			Volume [cm ³]	Min curve radius [mm]	Max vertical movement [mm]	Suction cup weight [g]
	-20 kPa	-60 kPa	-90 kPa	-20 kPa	-60 kPa	-90 kPa				
NBR 60	12.4	32.3	41.5	11	16.2	20.8	2	25	2	2.6
HNBR 60	12.4	32.3	41.5	11	16.2	20.8	2	25	2	2.1

Technical features

Material	Color	Hardness	Temperature range
NBR	Black	60 Shore	-22 - +212 °F
HNBR	Blue	60 Shore	-13 - +302 °F

Identification codes			
Drawing	Alphanumeric code	Suction cups with fitting	Order code
A	VG.CF33N.60.M5F	VG.CF33 suction cup, NBR, 60 Shore, M5 female	2321980
B	VG.CF33N.60.G18M	VG.CF33 suction cup, NBR, 60 Shore, G1/8" male	2321982
C	VG.CF33N.60.G18MF	VG.CF33 suction cup, NBR, 60 Shore, G1/8" male/M5 female	2321983
D	VG.CF33N.60.G18MFV	VG.CF33 suction cup, NBR, 60 Shore, G1/8" male/M5 female with valve	2321984
A	VG.CF33H.60.M5F	VG.CF33 suction cup, HNBR, 60 Shore, M5 female	2322022
B	VG.CF33H.60.G18M	VG.CF33 suction cup, HNBR, 60 Shore, G1/8" male	2322024
C	VG.CF33H.60.G18MF	VG.CF33 suction cup, HNBR, 60 Shore, G1/8" male/M5 female	2322025
D	VG.CF33H.60.G18MFV	VG.CF33 suction cup, HNBR, 60 Shore, G1/8" male/M5 female with valve	2322026

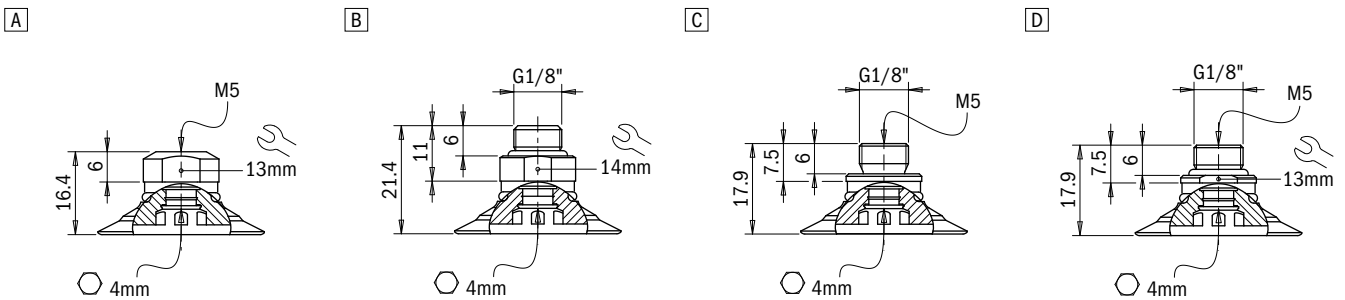

Identification codes			
Drawing	Alphanumeric code	Suction cups	Order code
A	VG.CF33N.60	VG.CF33 suction cup, NBR, 60 Shore	2321981
A	VG.CF33H.60	VG.CF33 suction cup, HNBR, 60 Shore	2322023

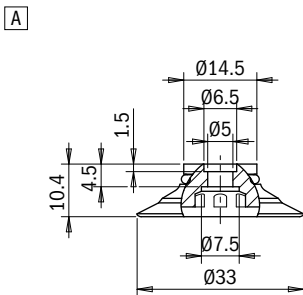

Identification codes			
Drawing	Alphanumeric code	Fittings	Order code
A	FT.M5F	Fitting, M5 female	1700006
B	FT.G18M.17	G1/8" male fitting	1700018
C	FT.G18M.M5F	G1/8" male / M5 female fitting	1700016
D	FT.G18M.M5F.VF	G1/8" male / M5 female fitting, with valve	1700017

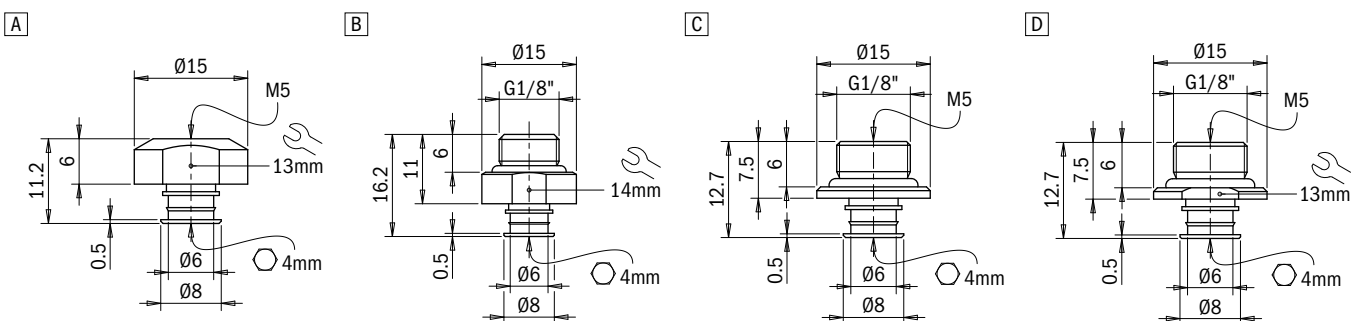

Suction cups / NBR-HNBR

VG.CF42 flat suction cups, NBR-HNBR, with reinforcements

- Ideal for handling plastic parts and dry sheet metal
- Suitable for items with flat surfaces
- Suitable for handling items with lifting force parallel to the surface thanks to the reinforcements that increase friction and prevent deformations
- The HNBR version enables to work at high temperatures, whereas silicone or other mixtures may release traces of material
- The HNBR compound is robust and wear resistant, suitable for the removal of hot plastic parts from the relevant moulds
- HNBR and NBR compounds are ideal for applications where contamination of the material must be avoided (PWIS)

Application example

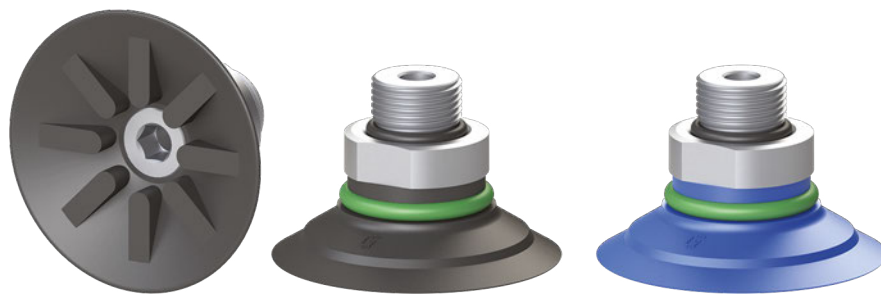

Technical data

Material	Lifting force [N] perpendicular to the surface, at various vacuum levels			Lifting force [N] parallel to the surface, at various vacuum levels			Volume [cm ³]	Min curve radius [mm]	Max vertical movement [mm]	Suction cup weight [g]
	-20 kPa	-60 kPa	-90 kPa	-20 kPa	-60 kPa	-90 kPa				
NBR 60	21.8	52	68	15	24.5	31	4.8	52	1.8	6.3
HNBR 60	21.8	52	68	15	24.5	31	4.8	52	1.8	5.2

Technical features

Material	Color	Hardness	Temperature range
NBR	Black	60 Shore	-22 - +212 °F
HNBR	Blue	60 Shore	-13 - +302 °F

Identification codes

Drawing	Alphanumeric code	Suction cups with fitting	Order code
A	VG.CF42N.60.G18F	VG.CF42 suction cup, NBR, 60 Shore, G1/8" female	2321985
B	VG.CF42N.60.G18M	VG.CF42 suction cup, NBR, 60 Shore, G1/8" male	2321987
C	VG.CF42N.60.G14M	VG.CF42 suction cup, NBR, 60 Shore, G1/4" male	2321988
D	VG.CF42N.60.G38M	VG.CF42 suction cup, NBR, 60 Shore, G3/8" male	2321989
A	VG.CF42H.60.G18F	VG.CF42 suction cup, HNBR, 60 Shore, G1/8" female	2322027
B	VG.CF42H.60.G18M	VG.CF42 suction cup, HNBR, 60 Shore, G1/8" male	2322029
C	VG.CF42H.60.G14M	VG.CF42 suction cup, HNBR, 60 Shore, G1/4" male	2322030
D	VG.CF42H.60.G38M	VG.CF42 suction cup, HNBR, 60 Shore, G3/8" male	2322031

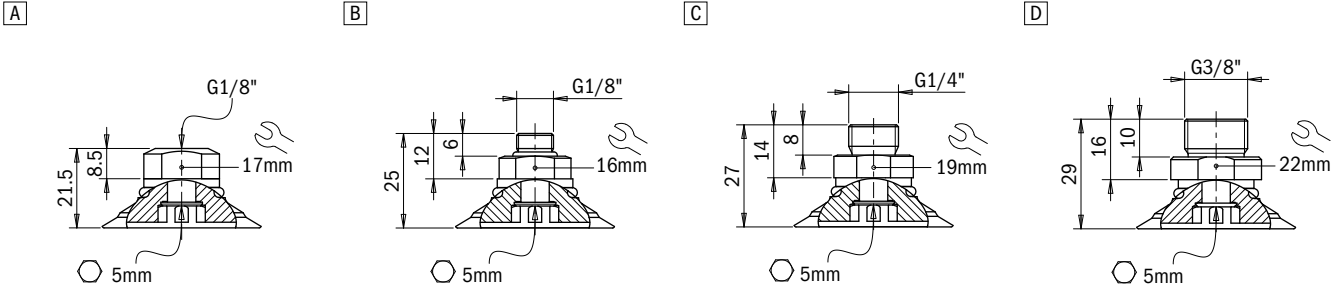

Identification codes

Drawing	Alphanumeric code	Suction cups	Order code
A	VG.CF42N.60	VG.CF42 suction cup, NBR, 60 Shore	2321986
A	VG.CF42H.60	VG.CF42 suction cup, HNBR, 60 Shore	2322028

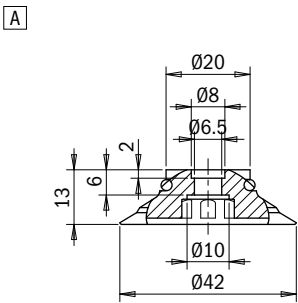

Identification codes

Drawing	Alphanumeric code	Fittings	Order code
A	FT.G18F.18	G1/8" female fitting	1800019
B	FT.G18M.18	G1/8" male fitting	1800018
C	FT.G14M.18	G1/4" male fitting	1800014
D	FT.G38M.18	G3/8" male fitting	1800038

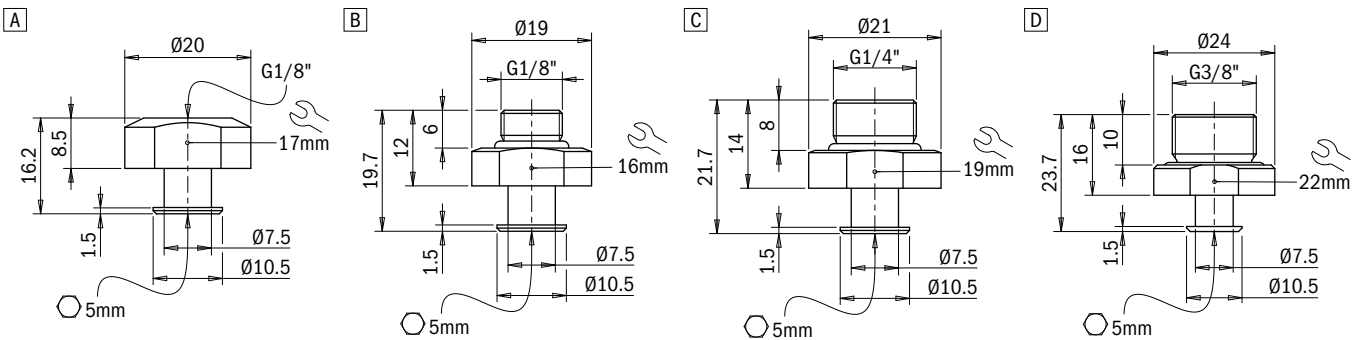

Suction cups / NBR-HNBR

VG.CF53 flat suction cups, NBR-HNBR, with reinforcements

- Ideal for handling plastic parts and dry sheet metal
- Suitable for items with flat surfaces
- Suitable for handling items with lifting force parallel to the surface thanks to the reinforcements that increase friction and prevent deformations
- The HNBR version enables to work at high temperatures, whereas silicone or other mixtures may release traces of material
- The HNBR compound is robust and wear resistant, suitable for the removal of hot plastic parts from the relevant moulds
- HNBR and NBR compounds are ideal for applications where contamination of the material must be avoided (PWIS)

Application example

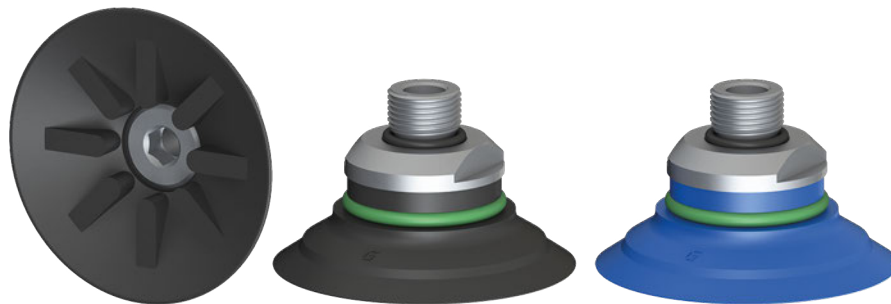

Technical data

Material	Lifting force [N] perpendicular to the surface, at various vacuum levels			Lifting force [N] parallel to the surface, at various vacuum levels			Volume [cm ³]	Min curve radius [mm]	Max vertical movement [mm]	Suction cup weight [g]
	-20 kPa	-60 kPa	-90 kPa	-20 kPa	-60 kPa	-90 kPa				
NBR 60	36.7	72	98	25	42	49	10	55	2.2	13.1
HNBR 60	36.7	72	98	25	42	49	10	55	2.2	10.8

Technical features

Material	Color	Hardness	Temperature range
NBR	Black	60 Shore	-22 - +212 °F
HNBR	Blue	60 Shore	-13 - +302 °F

Identification codes

Drawing	Alphanumeric code	Suction cups with fitting	Order code
A	VG.CF53N.60.G18F	VG.CF53 suction cup, NBR, 60 Shore, G1/8" female	2321990
B	VG.CF53N.60.G18M	VG.CF53 suction cup, NBR, 60 Shore, G1/8" male	2321992
C	VG.CF53N.60.G14M	VG.CF53 suction cup, NBR, 60 Shore, G1/4" male	2321993
D	VG.CF53N.60.G38M	VG.CF53 suction cup, NBR, 60 Shore, G3/8" male	2321994
A	VG.CF53H.60.G18F	VG.CF53 suction cup, HNBR, 60 Shore, G1/8" female	2322032
B	VG.CF53H.60.G18M	VG.CF53 suction cup, HNBR, 60 Shore, G1/8" male	2322034
C	VG.CF53H.60.G14M	VG.CF53 suction cup, HNBR, 60 Shore, G1/4" male	2322035
D	VG.CF53H.60.G38M	VG.CF53 suction cup, HNBR, 60 Shore, G3/8" male	2322036

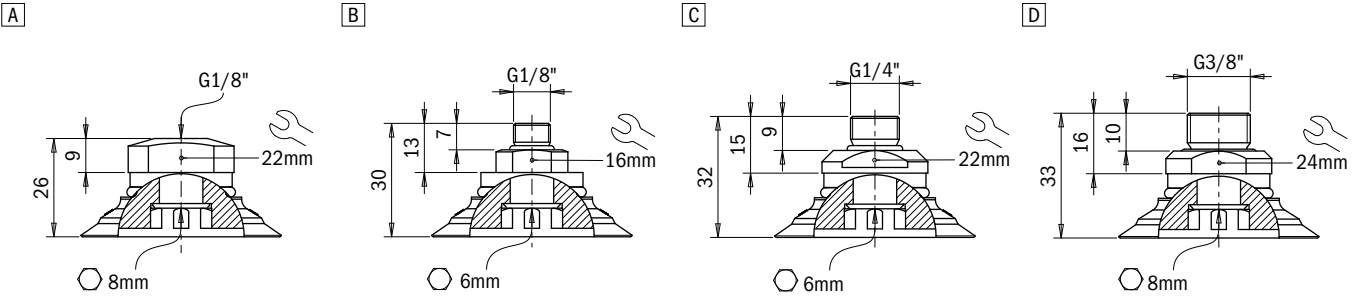

Identification codes

Drawing	Alphanumeric code	Suction cups	Order code
A	VG.CF53N.60	VG.CF53 suction cup, NBR, 60 Shore	2321991
A	VG.CF53H.60	VG.CF53 suction cup, HNBR, 60 Shore	2322033

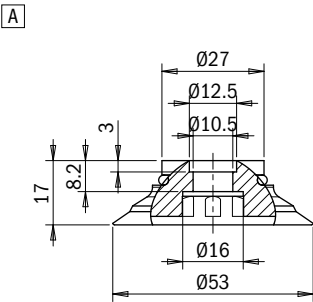

Identification codes

Drawing	Alphanumeric code	Fittings	Order code
A	FT.G18F.19	G1/8" female fitting	1900019
B	FT.G18M.19	G1/8" male fitting	1900018
C	FT.G14M.19	G1/4" male fitting	1900014
D	FT.G38M.198	G3/8" male fitting	1900038

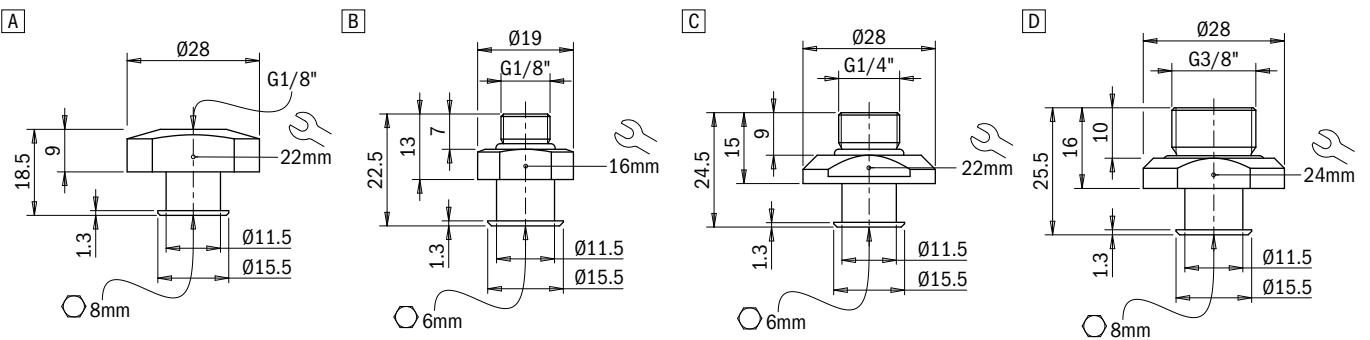

Suction cups / NBR-HNBR

VG.CF77 flat suction cups, NBR-HNBR, with reinforcements

- Ideal for handling plastic parts and dry sheet metal
- Suitable for items with flat surfaces
- Suitable for handling items with lifting force parallel to the surface thanks to the reinforcements that increase friction and prevent deformations
- The HNBR version enables to work at high temperatures, whereas silicone or other mixtures may release traces of material
- The HNBR compound is robust and wear resistant, suitable for the removal of hot plastic parts from the relevant moulds
- HNBR and NBR compounds are ideal for applications where contamination of the material must be avoided (PWIS)

Application example

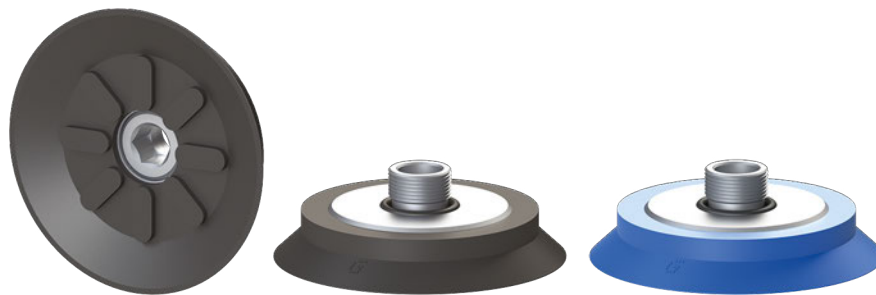
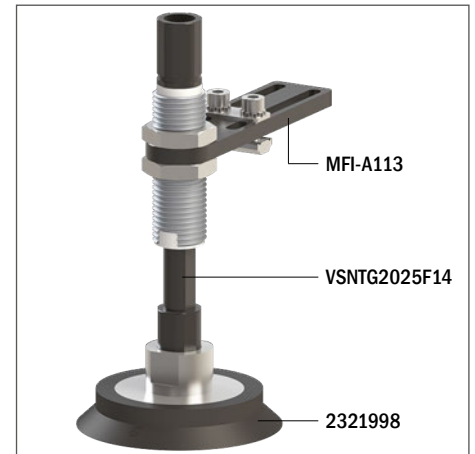

Technical data

Material	Lifting force [N] perpendicular to the surface, at various vacuum levels			Lifting force [N] parallel to the surface, at various vacuum levels			Volume [cm ³]	Min curve radius [mm]	Max vertical movement [mm]	Suction cup weight [g]
	-20 kPa	-60 kPa	-90 kPa	-20 kPa	-60 kPa	-90 kPa				
NBR 60	90	215	290	60	118	145	20	150	3	38.6
HNBR 60	90	215	290	60	118	145	20	150	3	31.3

Technical features

Material	Color	Hardness	Temperature range
NBR	Black	60 Shore	-22 - +212 °F
HNBR	Blue	60 Shore	-13 - +302 °F

Identification codes

Drawing	Alphanumeric code	Suction cups with fitting	Order code
A	VG.CF77N.60.G18F	VG.CF77 suction cup, NBR, 60 Shore, G1/8" female	2321995
B	VG.CF77N.60.G38F	VG.CF77 suction cup, NBR, 60 Shore, G3/8" female	2321997
C	VG.CF77N.60.G14M	VG.CF77 suction cup, NBR, 60 Shore, G1/4" male	2321998
D	VG.CF77H.60.G38M	VG.CF77 suction cup, HNBR, 60 Shore, G3/8" male	2321999
A	VG.CF77H.60.G18F	VG.CF77 suction cup, HNBR, 60 Shore, G1/8" female	2322037
B	VG.CF77H.60.G38F	VG.CF77 suction cup, HNBR, 60 Shore, G3/8" female	2322039
C	VG.CF77H.60.G14M	VG.CF77 suction cup, HNBR, 60 Shore, G1/4" male	2322040
D	VG.CF77H.60.G38M	VG.CF77 suction cup, HNBR, 60 Shore, G3/8" male	2322041

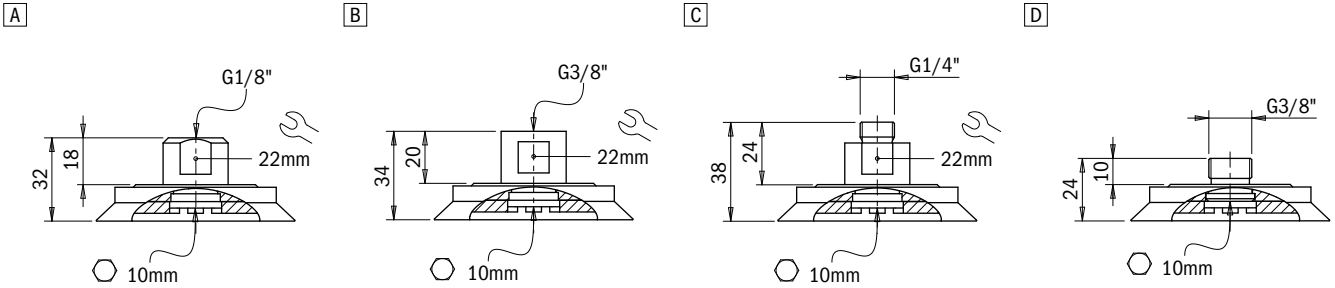

Identification codes

Drawing	Alphanumeric code	Suction cups	Order code
A	VG.CF77N.60	VG.CF77 suction cup, NBR, 60 Shore	2321996
A	VG.CF77H.60	VG.CF77 suction cup, HNBR, 60 Shore	2322038



Click for Pricing & Add to Cart

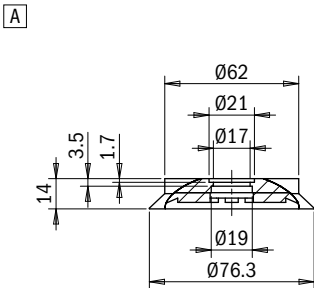

Identification codes

Drawing	Alphanumeric code	Fittings	Order code
A	FT.G18F.16	G1/8" female fitting	1600008
B	FT.G38F	G3/8" female fitting	1600009
C	FT.G14M.16	G1/4" male fitting	1600010
D	FT.G38M.199	G3/8" male fitting	1900039

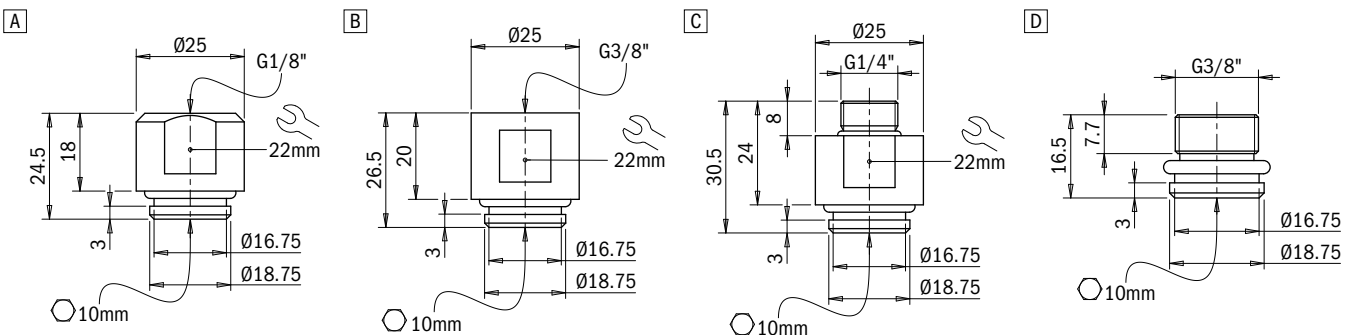

Suction cups / NBR-HNBR

VG.CF112 flat suction cups, NBR-HNBR, with reinforcements

- Ideal for handling plastic parts and dry sheet metal
- Suitable for items with flat surfaces
- Suitable for handling items with lifting force parallel to the surface thanks to the reinforcements that increase friction and prevent deformations
- The HNBR version enables to work at high temperatures, whereas silicone or other mixtures may release traces of material
- The HNBR compound is robust and wear resistant, suitable for the removal of hot plastic parts from the relevant moulds
- HNBR and NBR compounds are ideal for applications where contamination of the material must be avoided (PWIS)

Application example

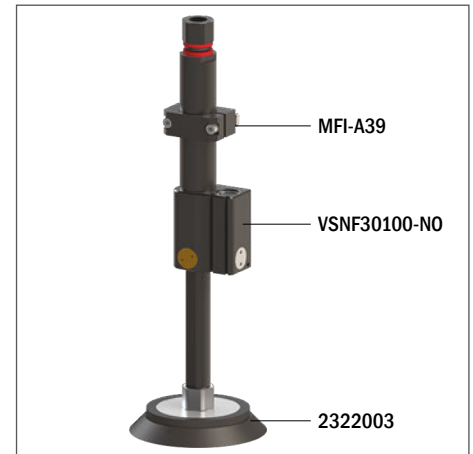

Technical data

Material	Lifting force [N] perpendicular to the surface, at various vacuum levels			Lifting force [N] parallel to the surface, at various vacuum levels			Volume [cm ³]	Min curve radius [mm]	Max vertical movement [mm]	Suction cup weight [g]
	-20 kPa	-60 kPa	-90 kPa	-20 kPa	-60 kPa	-90 kPa				
NBR 60	160	465	570	145	259	310	70	250	4	98.6
HNBR 60	160	465	570	145	259	310	70	250	4	80.2

Technical features

Material	Color	Hardness	Temperature range
NBR	Black	60 Shore	-22 - +212 °F
HNBR	Blue	60 Shore	-13 - +302 °F

Identification codes			
Drawing	Alphanumeric code	Suction cups with fitting	Order code
A	VG.CF112N.60.G38F	VG.CF112 suction cup, NBR, 60 Shore, G3/8" female	2322000
B	VG.CF112N.60.G14M	VG.CF112 suction cup, NBR, 60 Shore, G1/4" male	2322002
C	VG.CF112N.60.G38M	VG.CF112 suction cup, NBR, 60 Shore, G3/8" male	2322003
D	VG.CF112N.60.G12M	VG.CF112 suction cup, NBR, 60 Shore, G1/2" male	2322004
A	VG.CF112H.60.G38F	VG.CF112 suction cup, HNBR, 60 Shore, G3/8" female	2322042
B	VG.CF112H.60.G14M	VG.CF112 suction cup, HNBR, 60 Shore, G1/4" male	2322044
C	VG.CF112H.60.G38M	VG.CF112 suction cup, HNBR, 60 Shore, G3/8" male	2322045
D	VG.CF112H.60.G12M	VG.CF112 suction cup, HNBR, 60 Shore, G1/2" male	2322046

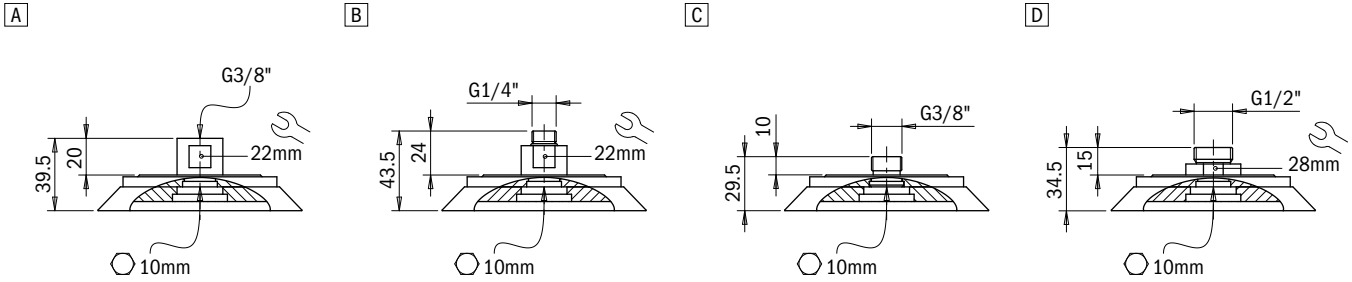

Identification codes			
Drawing	Alphanumeric code	Suction cups	Order code
A	VG.CF112N.60	VG.CF112 suction cup, NBR, 60 Shore	2322001
A	VG.CF112H.60	VG.CF112 suction cup, HNBR, 60 Shore	2322043

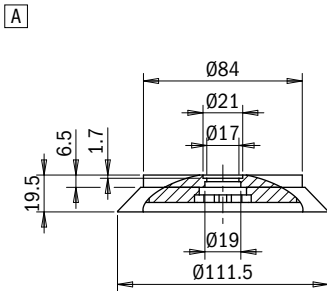

Identification codes			
Drawing	Alphanumeric code	Fittings	Order code
A	FT.G38F	G3/8" female fitting	1600009
B	FT.G14M.16	G1/4" male fitting	1600010
C	FT.G38M.199	G3/8" male fitting	1900039
D	FT.G12M.16	G1/2" male fitting	1600015

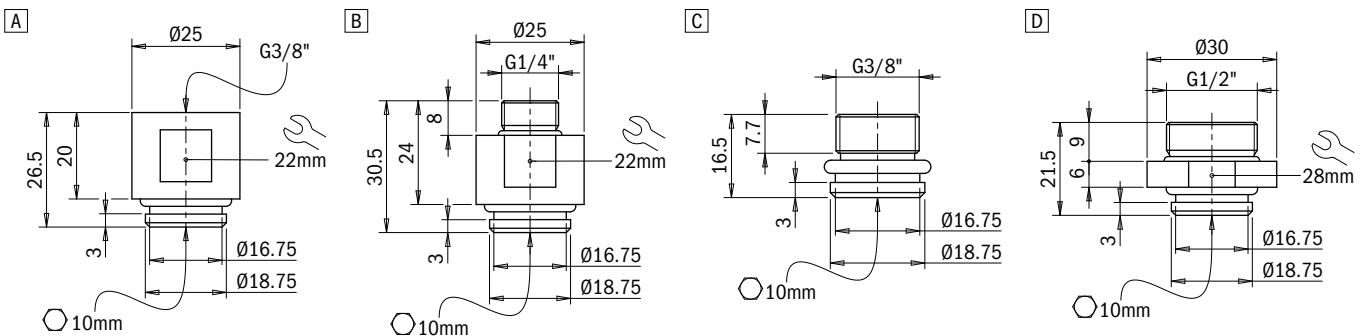

Suction cups / NBR-HNBR

VG.CF152 flat suction cups, NBR-HNBR, with reinforcements

- Ideal for handling plastic parts and dry sheet metal
- Suitable for items with flat surfaces
- Suitable for handling items with lifting force parallel to the surface thanks to the reinforcements that increase friction and prevent deformations
- The HNBR version enables to work at high temperatures, whereas silicone or other mixtures may release traces of material
- The HNBR compound is robust and wear resistant, suitable for the removal of hot plastic parts from the relevant moulds
- HNBR and NBR compounds are ideal for applications where contamination of the material must be avoided (PWIS)

Application example

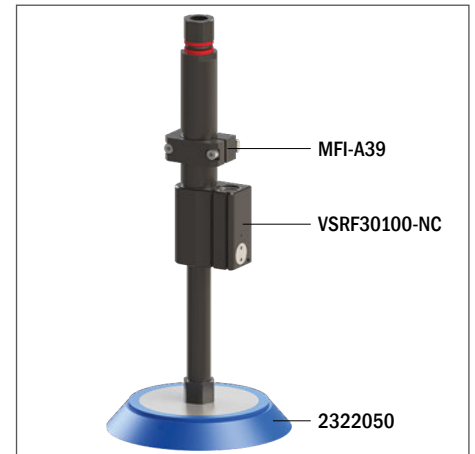

Technical data

Material	Lifting force [N] perpendicular to the surface, at various vacuum levels			Lifting force [N] parallel to the surface, at various vacuum levels			Volume [cm ³]	Min curve radius [mm]	Max vertical movement [mm]	Suction cup weight [g]
	-20 kPa	-60 kPa	-90 kPa	-20 kPa	-60 kPa	-90 kPa				
NBR 60	310	900	1195	245	620	815	160	500	6	219
HNBR 60	310	900	1195	245	620	815	160	500	6	178

Technical features

Material	Color	Hardness	Temperature range
NBR	Black	60 Shore	-22 - +212 °F
HNBR	Blue	60 Shore	-13 - +302 °F

Identification codes

Drawing	Alphanumeric code	Suction cups with fitting	Order code
A	VG.CF152N.60.G38F	VG.CF152 suction cup, NBR, 60 Shore, G3/8" female	2322005
B	VG.CF152N.60.G14M	VG.CF152 suction cup, NBR, 60 Shore, G1/4" male	2322007
C	VG.CF152N.60.G38M	VG.CF152 suction cup, NBR, 60 Shore, G3/8" male	2322008
D	VG.CF152N.60.G12F	VG.CF152 suction cup, NBR, 60 Shore, G1/2" female	2322009
A	VG.CF152H.60.G38F	VG.CF152 suction cup, HNBR, 60 Shore, G3/8" female	2322047
B	VG.CF152H.60.G14M	VG.CF152 suction cup, HNBR, 60 Shore, G1/4" male	2322049
C	VG.CF152H.60.G38M	VG.CF152 suction cup, HNBR, 60 Shore, G3/8" male	2322050
D	VG.CF152H.60.G12F	VG.CF152 suction cup, HNBR, 60 Shore, G1/2" female	2322051

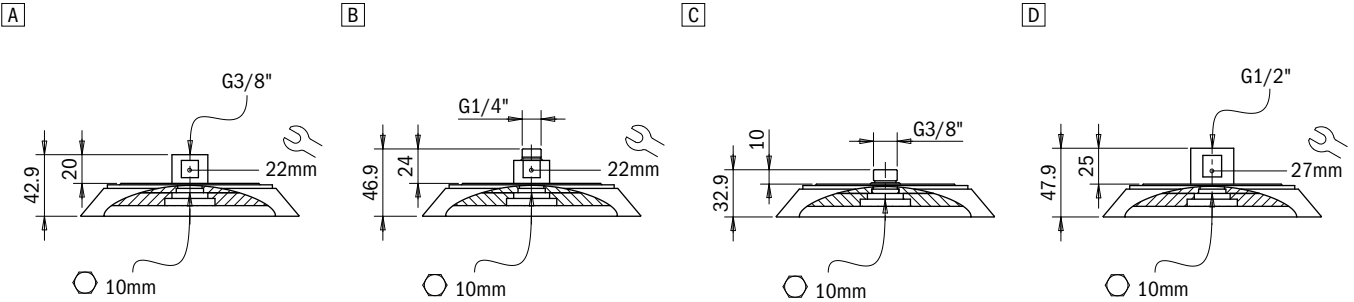

Identification codes

Drawing	Alphanumeric code	Suction cups	Order code
A	VG.CF152N.60	VG.CF152 suction cup, NBR, 60 Shore	2322006
A	VG.CF152H.60	VG.CF152 suction cup, HNBR, 60 Shore	2322048

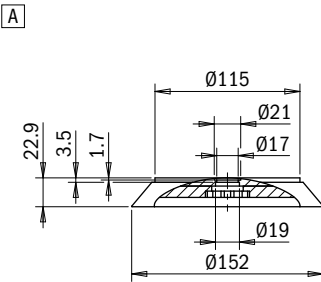

Identification codes

Drawing	Alphanumeric code	Fittings	Order code
A	FT.G38F	G3/8" female fitting	1600009
B	FT.G14M.16	G1/4" male fitting	1600010
C	FT.G38M.199	G3/8" male fitting	1900039
D	FT.G12F	G1/2" female fitting	1600019

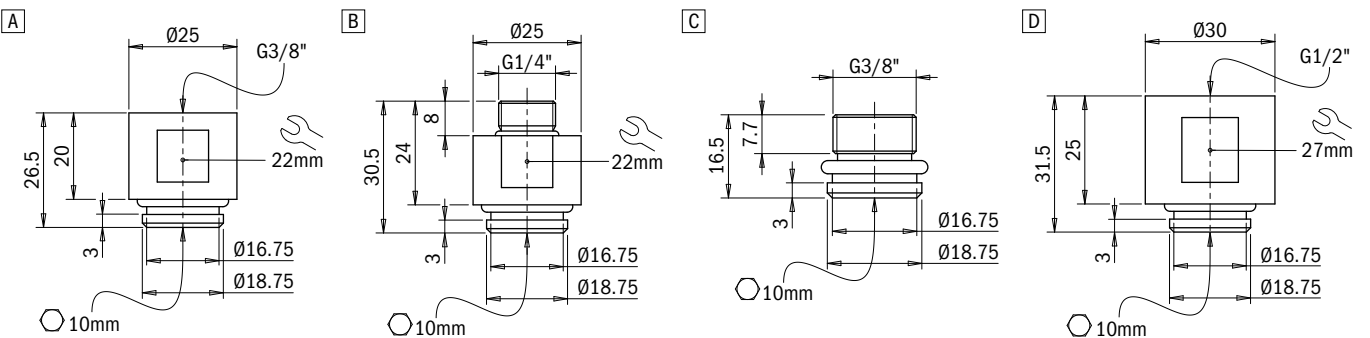

Suction cups / NBR-HNBR

VG.LB6 bellows suction cups in NBR-HNBR

- Suitable for handling plastic parts
- Suitable for objects with flat or slightly curved surfaces
- They enable to compensate for differences in height
- Ideal for leafing through and picking up thin metal sheets, glass sheets, chipboard or pressed wood panels, plastic laminates
- The HNBR version enables to work at high temperatures, whereas silicone or other mixtures may release traces of material. Ideal for applications where contamination of the material must be avoided (PWIS)
- The HNBR compound is robust and wear resistant, suitable for the removal of hot plastic parts from the relevant moulds

Application example

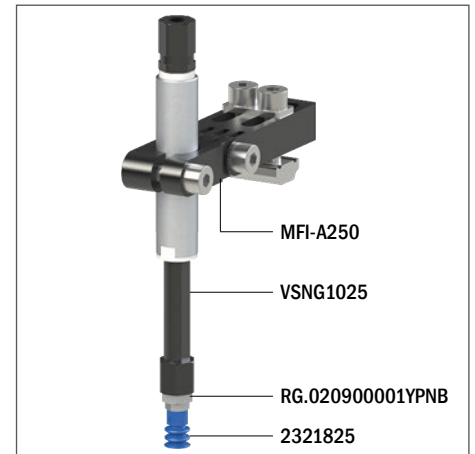

Technical data

Material	Lifting force [N] perpendicular to the surface, at various vacuum levels			Lifting force [N] parallel to the surface, at various vacuum levels			Volume [cm ³]	Min curve radius [mm]	Max vert. movement [mm]	Suction cup weight [g]
	-20 kPa	-60 kPa	-90 kPa	-20 kPa	-60 kPa	-90 kPa				
NBR 50	0.4	1.1	1.7	–	–	–	0.033	8	3	0.1
HNBR 60	0.4	1.1	1.7	–	–	–	0.033	8	3	0.1

Technical features

Material	Color	Hardness	Temperature range
NBR	Black	50 Shore	-40 - +212 °F
HNBR	Blue	60 Shore	-13 - +302 °F

Identification codes

Drawing	Alphanumeric code	Suction cups with fitting	Order code
A	VG.LB6N.50.M3M.E5	VG.LB6 suction cup, NBR, 50 Shore, M3 male, 5 mm hex	2321823
A	VG.LB6H.60.M3M.E5	VG.LB6 suction cup, HNBR, 60 Shore, M3 male, 5 mm hex	2321825
B	VG.LB6N.50.M5M.E8	VG.LB6 suction cup, NBR, 50 Shore, M5 male, 8 mm hex	2321023
B	VG.LB6H.60.M5M.E8	VG.LB6 suction cup, HNBR, 60 Shore, M5 male, 8 mm hex	2321025

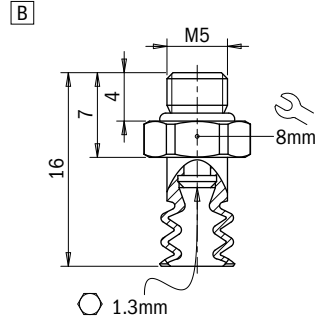
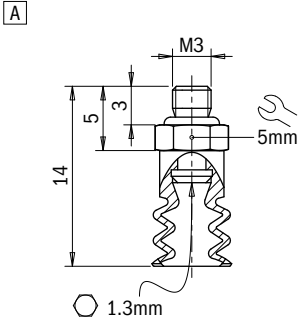

Identification codes

Drawing	Alphanumeric code	Suction cups	Order code
A	VG.LB6N.50	VG.LB6 suction cup, NBR, 50 Shore	2321824
A	VG.LB6H.60	VG.LB6 suction cup, HNBR, 60 Shore	2321826

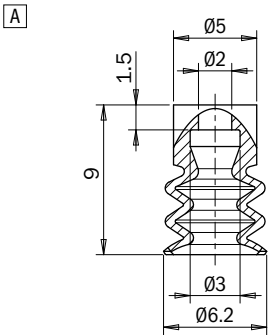

Identification codes

Drawing	Alphanumeric code	Fittings	Order code
A	FT.M3M.E5	M3 male fitting, 5 mm hex	2321402
B	FT.M5M.E8.06	M5 male fitting, 8 mm hex	2321005

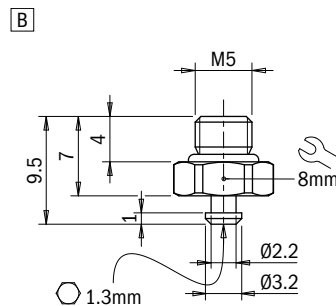
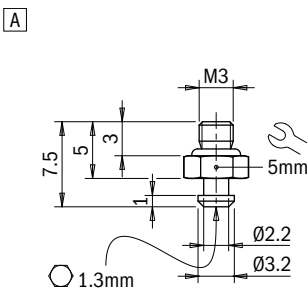

Suction cups / NBR-HNBR

VG.LB9 bellows suction cups in NBR-HNBR

- Suitable for handling plastic parts
- Suitable for objects with flat or slightly curved surfaces
- They enable to compensate for differences in height
- Ideal for leafing through and picking up thin metal sheets, glass sheets, chipboard or pressed wood panels, plastic laminates
- The HNBR version enables to work at high temperatures, whereas silicone or other mixtures may release traces of material. Ideal for applications where contamination of the material must be avoided (PWIS)
- The HNBR compound is robust and wear resistant, suitable for the removal of hot plastic parts from the relevant moulds

Application example

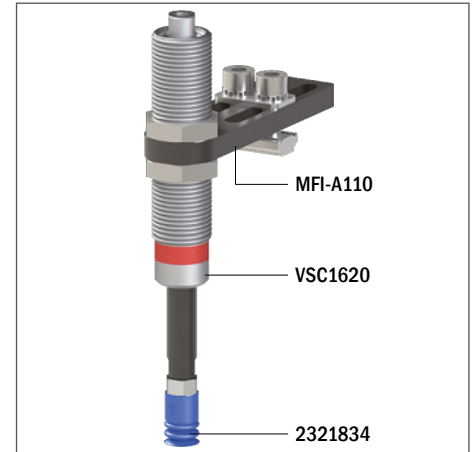

Technical data

Material	Lifting force [N] perpendicular to the surface, at various vacuum levels			Lifting force [N] parallel to the surface, at various vacuum levels			Volume [cm ³]	Min curve radius [mm]	Max vert. movement [mm]	Suction cup weight [g]
	-20 kPa	-60 kPa	-90 kPa	-20 kPa	-60 kPa	-90 kPa				
NBR 50	1.1	3	4.2	–	–	–	0.15	10	4	0.7
HNBR 60	1.1	3	4.2	–	–	–	0.15	10	4	0.5

Technical features

Material	Color	Hardness	Temperature range
NBR	Black	50 Shore	-40 - +212 °F
HNBR	Blue	60 Shore	-13 - +302 °F

Identification codes

Drawing	Alphanumeric code	Suction cups with fitting	Order code
A	VG.LB9N.50.M5F.E8	VG.LB9 suction cup, NBR, 50 Shore, M5 female, 8 mm hex	2321827
B	VG.LB9N.50.M5M.E8	VG.LB9 suction cup, NBR, 50 Shore, M5 male, 8 mm hex	2321829
C	VG.LB9N.50.G18F.E13	VG.LB9 suction cup, NBR, 50 Shore, G1/8" female, 13 mm hex	2321830
D	VG.LB9N.50.G18M.E13	VG.LB9 suction cup, NBR, 50 Shore, G1/8" male, 13 mm hex	2321831
A	VG.LB9H.60.M5F.E8	VG.LB9 suction cup, HNBR, 60 Shore, M5 female, 8 mm hex	2321832
B	VG.LB9H.60.M5M.E8	VG.LB9 suction cup, HNBR, 60 Shore, M5 male, 8 mm hex	2321834
C	VG.LB9H.60.G18F.E13	VG.LB9 suction cup, HNBR, 60 Shore, G1/8" female, 13 mm hex	2321835
D	VG.LB9H.60.G18M.E13	VG.LB9 suction cup, HNBR, 60 Shore, G1/8" male, 13 mm hex	2321836

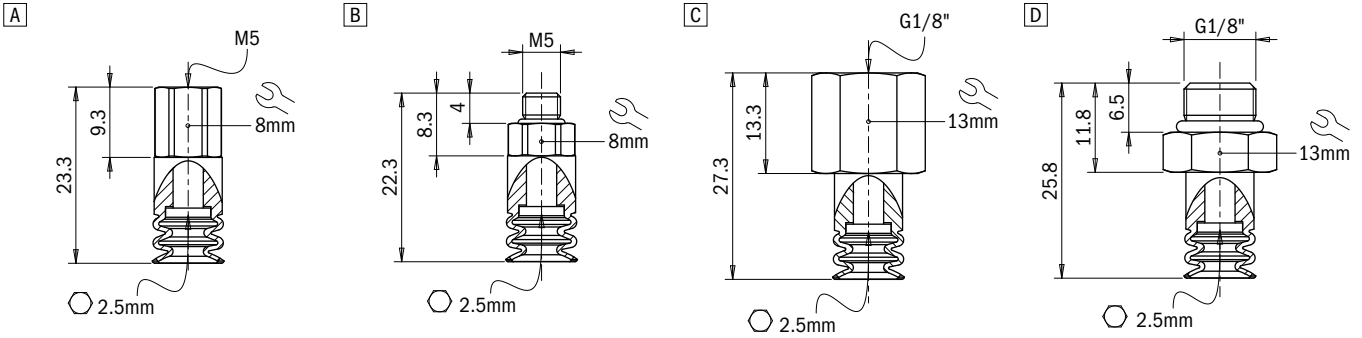

Identification codes

Drawing	Alphanumeric code	Suction cups	Order code
A	VG.LB9N.50	VG.LB9 suction cup, NBR, 50 Shore	2321828
A	VG.LB9H.60	VG.LB9 suction cup, HNBR, 60 Shore	2321833

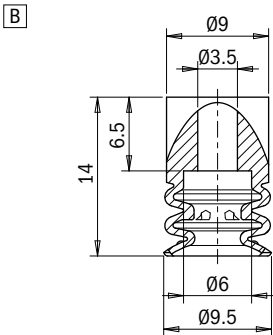

Identification codes

Drawing	Alphanumeric code	Fittings	Order code
A	FT.M5F.E8	M5 female fitting, 8 mm hex	2321408
B	FT.M5M.E8	M5 male fitting, 8 mm hex	2321410
C	FT.G18F.E13	G1/8" female fitting, 13 mm hex	2321412
D	FT.G18M.E13	G1/8" male fitting, 13 mm hex	2321414

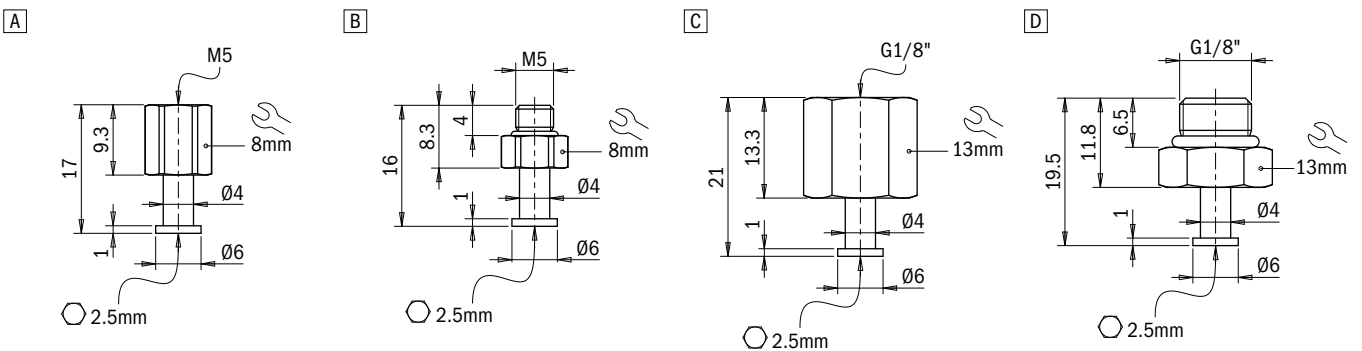

Suction cups / NBR-HNBR

VG.LB11 bellows suction cups in NBR-HNBR

- Suitable for handling plastic parts
- Suitable for objects with flat or slightly curved surfaces
- They enable to compensate for differences in height
- Ideal for leafing through and picking up thin metal sheets, glass sheets, chipboard or pressed wood panels, plastic laminates
- The HNBR version enables to work at high temperatures, whereas silicone or other mixtures may release traces of material. Ideal for applications where contamination of the material must be avoided (PWIS)
- The HNBR compound is robust and wear resistant, suitable for the removal of hot plastic parts from the relevant moulds

Application example

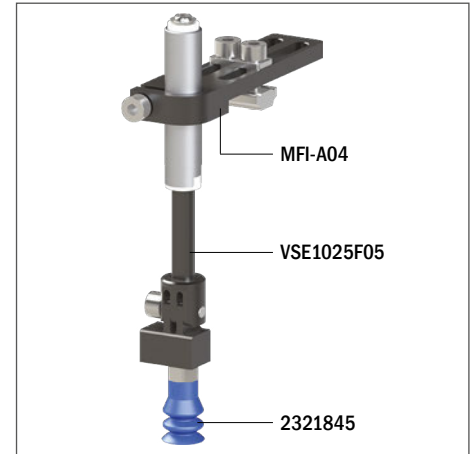

Technical data

Material	Lifting force [N] perpendicular to the surface, at various vacuum levels			Lifting force [N] parallel to the surface, at various vacuum levels			Volume [cm ³]	Min curve radius [mm]	Max vert. movement [mm]	Suction cup weight [g]
	-20 kPa	-60 kPa	-90 kPa	-20 kPa	-60 kPa	-90 kPa				
NBR 50	1.7	4.3	6.6	–	–	–	0.6	13	7	0.8
HNBR 60	1.7	4.3	6.6	–	–	–	0.6	13	7	0.6

Technical features

Material	Color	Hardness	Temperature range
NBR	Black	50 Shore	-40 - +212 °F
HNBR	Blue	60 Shore	-13 - +302 °F

Identification codes

Drawing	Alphanumeric code	Suction cups with fitting	Order code
A	VG.LB11N.50.M5F.E8	VG.LB11 suction cup, NBR, 50 Shore, M5 female, 8 mm hex	2321837
B	VG.LB11N.50.M5M.E8	VG.LB11 suction cup, NBR, 50 Shore, M5 male, 8 mm hex	2321839
C	VG.LB11N.50.G18F.E13	VG.LB11 suction cup, NBR, 50 Shore, G1/8" female, 13 mm hex	2321840
D	VG.LB11N.50.G18M.E13	VG.LB11 suction cup, NBR, 50 Shore, G1/8" male, 13 mm hex	2321841
A	VG.LB11H.60.M5F.E8	VG.LB11 suction cup, HNBR, 60 Shore, M5 female, 8 mm hex	2321842
B	VG.LB11H.60.M5M.E8	VG.LB11 suction cup, HNBR, 60 Shore, M5 male, 8 mm hex	2321845
C	VG.LB11H.60.G18F.E13	VG.LB11 suction cup, HNBR, 60 Shore, G1/8" female, 13 mm hex	2321846
D	VG.LB11H.60.G18M.E13	VG.LB11 suction cup, HNBR, 60 Shore, G1/8" male, 13 mm hex	2321847

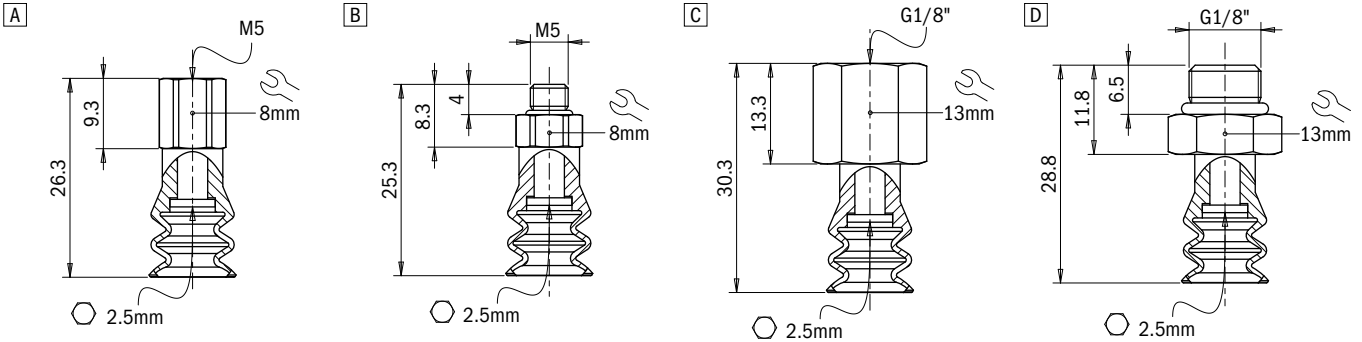

Identification codes

Drawing	Alphanumeric code	Suction cups	Order code
A	VG.LB11N.50	VG.LB11 suction cup, NBR, 50 Shore	2321838
A	VG.LB11H.60	VG.LB11 suction cup, HNBR, 60 Shore	2321843

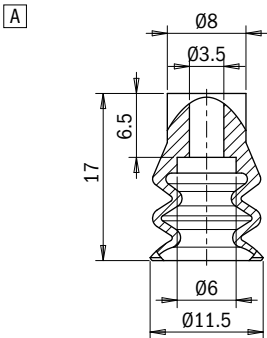

Click for Pricing & Add to Cart



Identification codes

Drawing	Alphanumeric code	Fittings	Order code
A	FT.M5F.E8	M5 female fitting, 8 mm hex	2321408
B	FT.M5M.E8	M5 male fitting, 8 mm hex	2321410
C	FT.G18F.E13	G1/8" female fitting, 13 mm hex	2321412
D	FT.G18M.E13	G1/8" male fitting, 13 mm hex	2321414

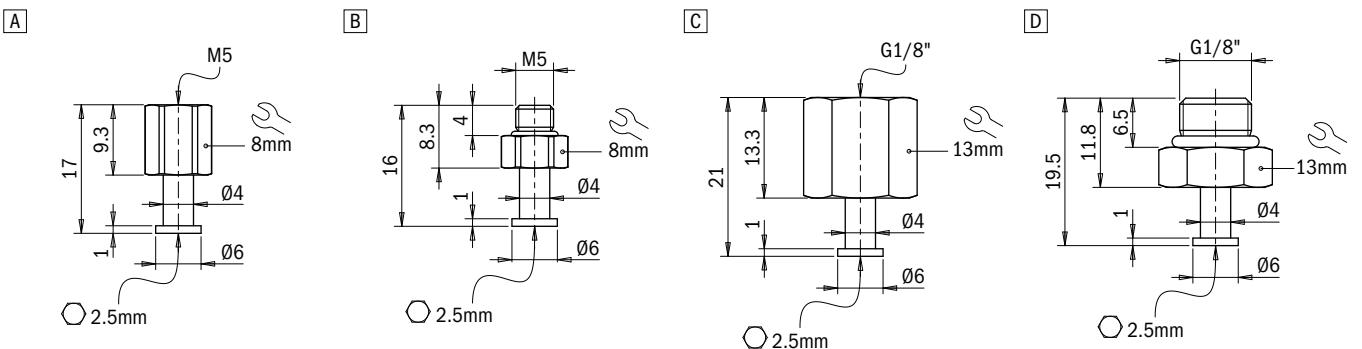

Suction cups / NBR-HNBR

VG.LB16 bellows suction cups in NBR-HNBR

- Suitable for handling plastic parts
- Suitable for objects with flat or slightly curved surfaces
- They enable to compensate for differences in height
- Ideal for leafing through and picking up thin metal sheets, glass sheets, chipboard or pressed wood panels, plastic laminates
- The HNBR version enables to work at high temperatures, whereas silicone or other mixtures may release traces of material. Ideal for applications where contamination of the material must be avoided (PWIS)
- The HNBR compound is robust and wear resistant, suitable for the removal of hot plastic parts from the relevant moulds

Application example

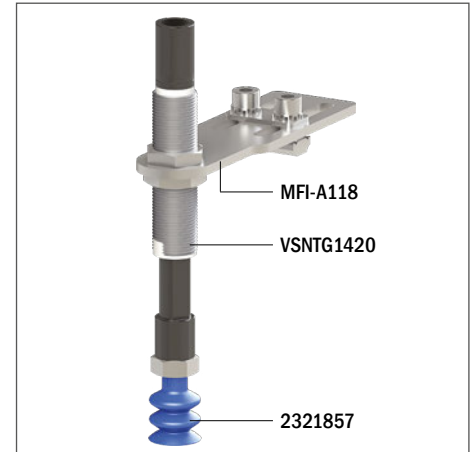

Technical data

Material	Lifting force [N] perpendicular to the surface, at various vacuum levels			Lifting force [N] parallel to the surface, at various vacuum levels			Volume [cm ³]	Min curve radius [mm]	Max vert. movement [mm]	Suction cup weight [g]
	-20 kPa	-60 kPa	-90 kPa	-20 kPa	-60 kPa	-90 kPa				
NBR 50	3.6	9.4	13.2	–	–	–	1.92	18	9	1.3
HNBR 60	3.6	9.4	13.2	–	–	–	1.92	18	9	1.1

Technical features

Material	Color	Hardness	Temperature range
NBR	Black	50 Shore	-40 - +212 °F
HNBR	Blue	60 Shore	-13 - +302 °F

Identification codes

Drawing	Alphanumeric code	Suction cups with fitting	Order code
A	VG.LB16N.50.M5F.E8	VG.LB16 suction cup, NBR, 50 Shore, M5 female, 8 mm hex	2321848
B	VG.LB16N.50.M5M.E8	VG.LB16 suction cup, NBR, 50 Shore, M5 male, 8 mm hex	2321850
C	VG.LB16N.50.G18F.E13	VG.LB16 suction cup, NBR, 50 Shore, G1/8" female, 13 mm hex	2321851
D	VG.LB16N.50.G18M.E13	VG.LB16 suction cup, NBR, 50 Shore, G1/8" male, 13 mm hex	2321852
A	VG.LB16H.60.M5F.E8	VG.LB16 suction cup, HNBR, 60 Shore, M5 female, 8 mm hex	2321853
B	VG.LB16H.60.M5M.E8	VG.LB16 suction cup, HNBR, 60 Shore, M5 male, 8 mm hex	2321855
C	VG.LB16H.60.G18F.E13	VG.LB16 suction cup, HNBR, 60 Shore, G1/8" female, 13 mm hex	2321856
D	VG.LB16H.60.G18M.E13	VG.LB16 suction cup, HNBR, 60 Shore, G1/8" male, 13 mm hex	2321857

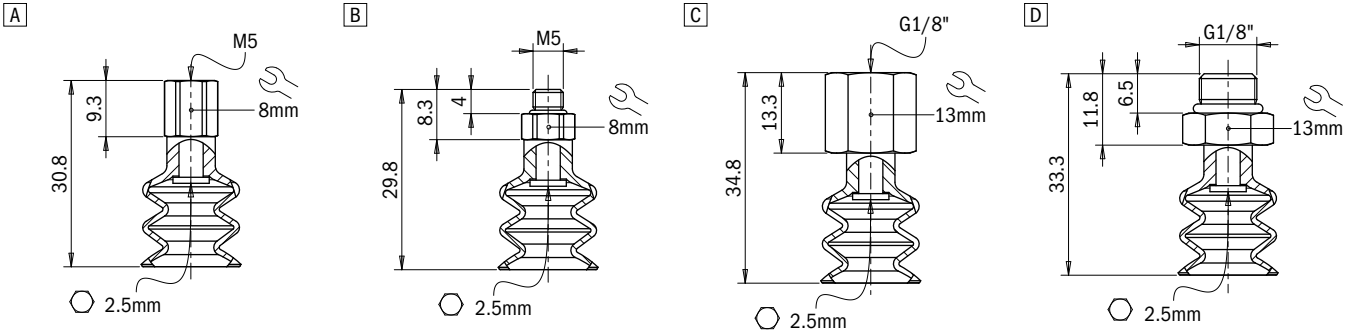

Identification codes

Drawing	Alphanumeric code	Suction cups	Order code
A	VG.LB16N.50	VG.LB16 suction cup, NBR, 50 Shore	2321849
A	VG.LB16H.60	VG.LB16 suction cup, HNBR, 60 Shore	2321854

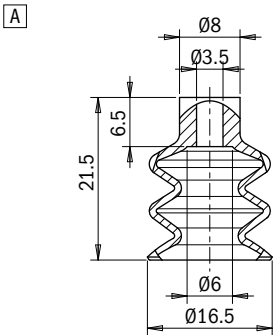

Identification codes

Drawing	Alphanumeric code	Fittings	Order code
A	FT.M5F.E8	M5 female fitting, 8 mm hex	2321408
B	FT.M5M.E8	M5 male fitting, 8 mm hex	2321410
C	FT.G18F.E13	G1/8" female fitting, 13 mm hex	2321412
D	FT.G18M.E13	G1/8" male fitting, 13 mm hex	2321414

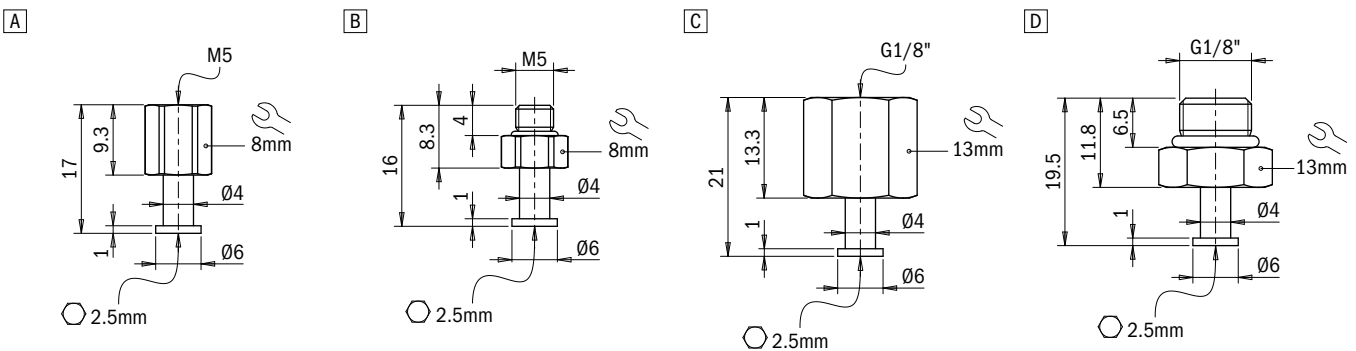

Suction cups / NBR-HNBR

VG.LB22 bellows suction cups in NBR-HNBR

- Suitable for handling plastic parts
- Suitable for objects with flat or slightly curved surfaces
- They enable to compensate for differences in height
- Ideal for leafing through and picking up thin metal sheets, glass sheets, chipboard or pressed wood panels, plastic laminates
- The HNBR version enables to work at high temperatures, whereas silicone or other mixtures may release traces of material. Ideal for applications where contamination of the material must be avoided (PWIS)
- The HNBR compound is robust and wear resistant, suitable for the removal of hot plastic parts from the relevant moulds

Application example

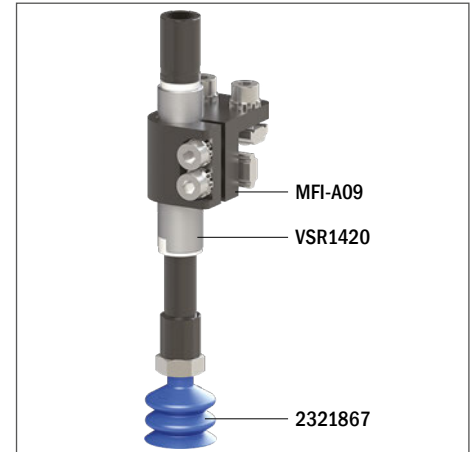

Technical data

Material	Lifting force [N] perpendicular to the surface, at various vacuum levels			Lifting force [N] parallel to the surface, at various vacuum levels			Volume [cm ³]	Min curve radius [mm]	Max vert. movement [mm]	Suction cup weight [g]
	-20 kPa	-60 kPa	-90 kPa	-20 kPa	-60 kPa	-90 kPa				
NBR 50	6.2	16.1	23.4	–	–	–	2	30	18	2.5
HNBR 60	6.2	16.1	23.4	–	–	–	2	30	18	2

Technical features

Material	Color	Hardness	Temperature range
NBR	Black	50 Shore	-40 - +212 °F
HNBR	Blue	60 Shore	-13 - +302 °F

Identification codes

Drawing	Alphanumeric code	Suction cups with fitting	Order code
A	VG.LB22N.50.M5F.E8	VG.LB22 suction cup, NBR, 50 Shore, M5 female, 8 mm hex	2321858
B	VG.LB22N.50.M5M.E8	VG.LB22 suction cup, NBR, 50 Shore, M5 male, 8 mm hex	2321860
C	VG.LB22N.50.G18F.E13	VG.LB22 suction cup, NBR, 50 Shore, G1/8" female, 13 mm hex	2321861
D	VG.LB22N.50.G18M.E13	VG.LB22 suction cup, NBR, 50 Shore, G1/8" male, 13 mm hex	2321862
A	VG.LB22H.60.M5F.E8	VG.LB22 suction cup, HNBR, 60 Shore, M5 female, 8 mm hex	2321863
B	VG.LB22H.60.M5M.E8	VG.LB22 suction cup, HNBR, 60 Shore, M5 male, 8 mm hex	2321865
C	VG.LB22H.60.G18F.E13	VG.LB22 suction cup, HNBR, 60 Shore, G1/8" female, 13 mm hex	2321866
D	VG.LB22H.60.G18M.E13	VG.LB22 suction cup, HNBR, 60 Shore, G1/8" male, 13 mm hex	2321867

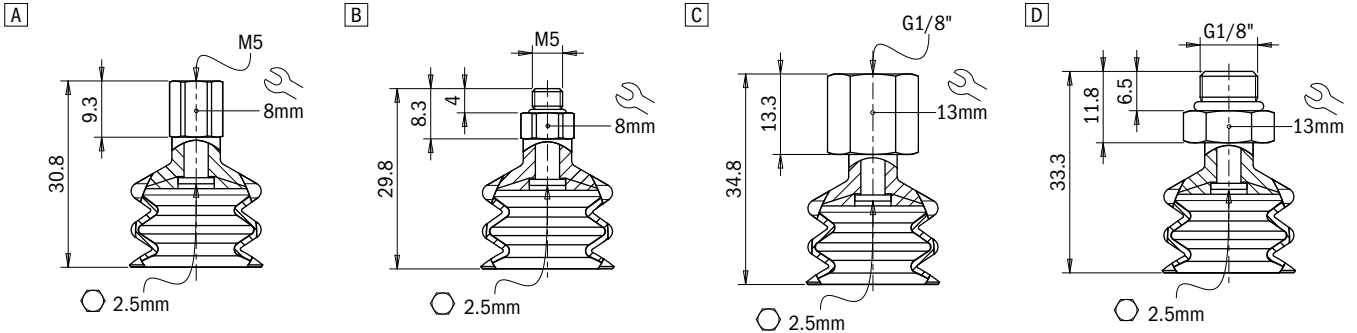

Identification codes

Drawing	Alphanumeric code	Suction cups	Order code
A	VG.LB22N.50	VG.LB22 suction cup, NBR, 50 Shore	2321859
A	VG.LB22H.60	VG.LB22 suction cup, HNBR, 60 Shore	2321864

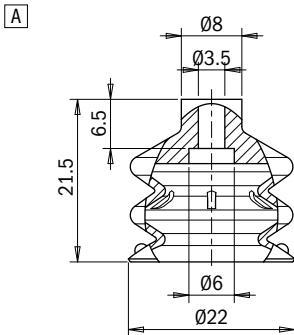

Identification codes

Drawing	Alphanumeric code	Fittings	Order code
A	FT.M5F.E8	M5 female fitting, 8 mm hex	2321408
B	FT.M5M.E8	M5 male fitting, 8 mm hex	2321410
C	FT.G18F.E13	G1/8" female fitting, 13 mm hex	2321412
D	FT.G18M.E13	G1/8" male fitting, 13 mm hex	2321414

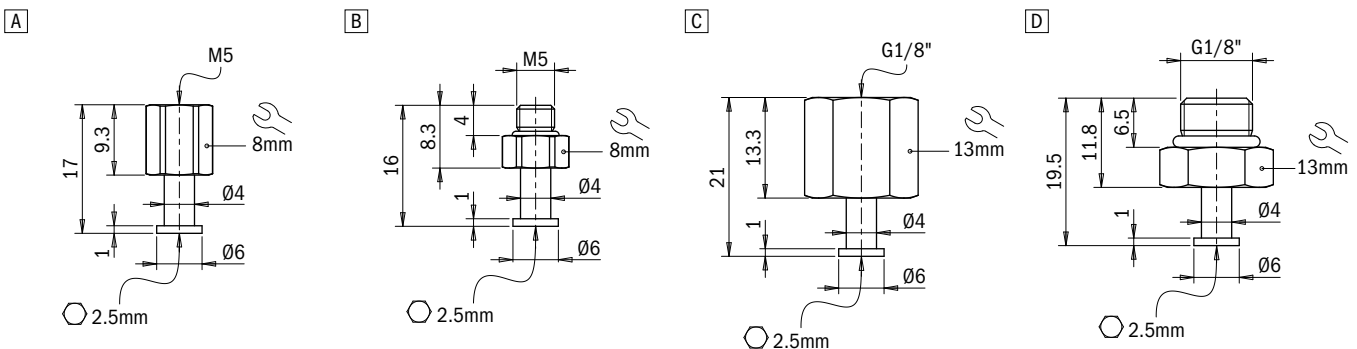

Suction cups / NBR-HNBR

VG.LB33 bellows suction cups in NBR-HNBR

- Suitable for handling plastic parts
- Suitable for objects with flat or slightly curved surfaces
- They enable to compensate for differences in height
- Ideal for leafing through and picking up thin metal sheets, glass sheets, chipboard or pressed wood panels, plastic laminates
- The HNBR version enables to work at high temperatures, whereas silicone or other mixtures may release traces of material. Ideal for applications where contamination of the material must be avoided (PWIS)
- The HNBR compound is robust and wear resistant, suitable for the removal of hot plastic parts from the relevant moulds

Application example

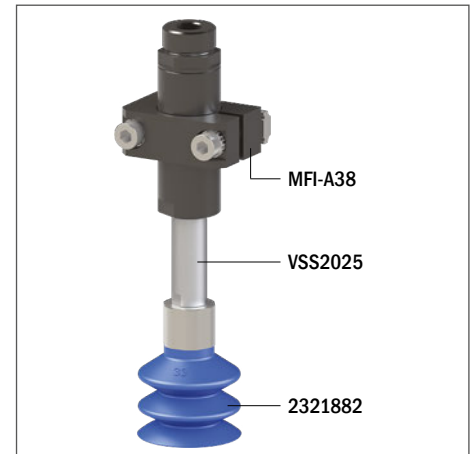

Technical data

Material	Lifting force [N] perpendicular to the surface, at various vacuum levels			Lifting force [N] parallel to the surface, at various vacuum levels			Volume [cm ³]	Min curve radius [mm]	Max vert. movement [mm]	Suction cup weight [g]
	-20 kPa	-60 kPa	-90 kPa	-20 kPa	-60 kPa	-90 kPa				
NBR 50	13.9	40.4	52.3	–	–	–	10	35	15	8.3
HNBR 60	13.9	40.4	52.3	–	–	–	10	35	15	6.7

Technical features

Material	Color	Hardness	Temperature range
NBR	Black	50 Shore	-40 - +212 °F
HNBR	Blue	60 Shore	-13 - +302 °F

Identification codes

Drawing	Alphanumeric code	Suction cups with fitting	Order code
A	VG.LB33N.50.G18F.E12	VG.LB33 suction cup, NBR, 50 Shore, G1/8" female, 12 mm hex	2321872
B	VG.LB33N.50.G18M.E12	VG.LB33 suction cup, NBR, 50 Shore, G1/8" male, 12 mm hex	2321874
C	VG.LB33N.50.G18F.E16	VG.LB33 suction cup, NBR, 50 Shore, G1/8" female, 16 mm hex	2321875
D	VG.LB33N.50.G18M.E16	VG.LB33 suction cup, NBR, 50 Shore, G1/8" male, 16 mm hex	2321876
E	VG.LB33N.50.G14F.E16	VG.LB33 suction cup, NBR, 50 Shore, G1/4" female, 16 mm hex	2321877
F	VG.LB33N.50.G14M.E17	VG.LB33 suction cup, NBR, 50 Shore, G1/4" male, 17 mm hex	2321878
A	VG.LB33H.60.G18F.E12	VG.LB33 suction cup, HNBR, 60 Shore, G1/8" female, 12 mm hex	2321879
B	VG.LB33H.60.G18M.E12	VG.LB33 suction cup, HNBR, 60 Shore, G1/8" male, 12 mm hex	2321881
C	VG.LB33H.60.G18F.E16	VG.LB33 suction cup, HNBR, 60 Shore, G1/8" female, 16 mm hex	2321882
D	VG.LB33H.60.G18M.E16	VG.LB33 suction cup, HNBR, 60 Shore, G1/8" male, 16 mm hex	2321883
E	VG.LB33H.60.G14F.E16	VG.LB33 suction cup, HNBR, 60 Shore, G1/4" female, 16 mm hex	2321884
F	VG.LB33H.60.G14M.E17	VG.LB33 suction cup, HNBR, 60 Shore, G1/4" male, 17 mm hex	2321885

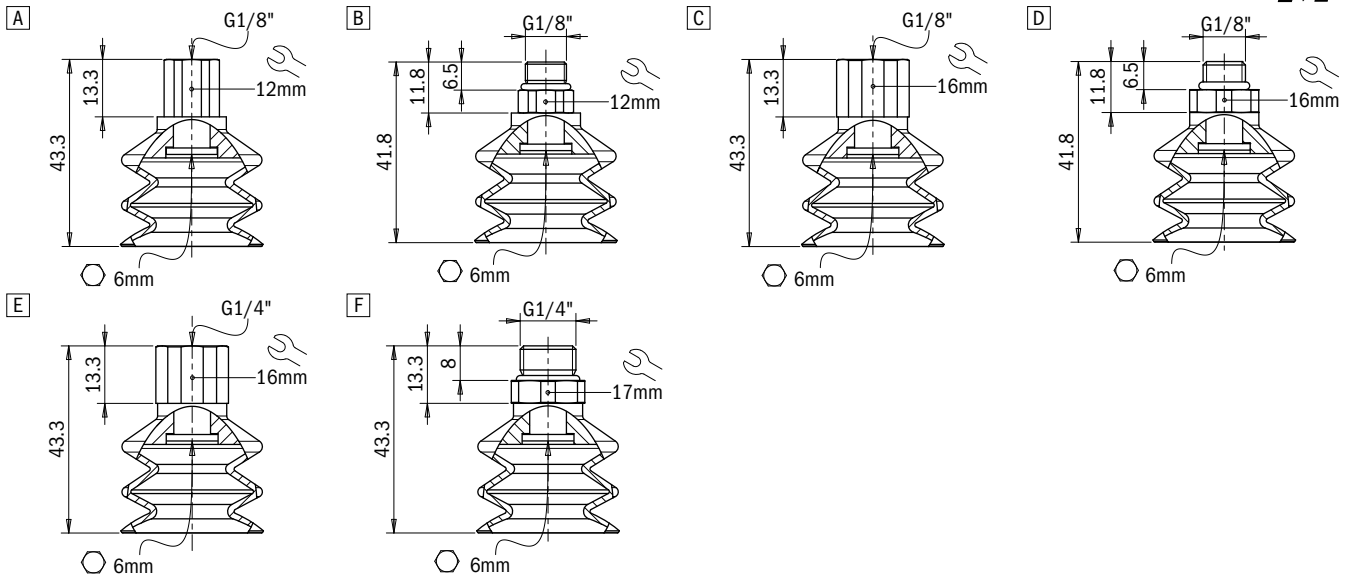

Identification codes

Drawing	Alphanumeric code	Suction cups	Order code
A	VG.LB33N.50	VG.LB33 suction cup, NBR, 50 Shore	2321873
A	VG.LB33H.60	VG.LB33 suction cup, HNBR, 60 Shore	2321880

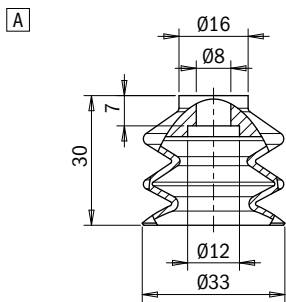

Identification codes

Drawing	Alphanumeric code	Fittings	Order code
A	FT.G18F.E12	G1/8" female fitting, 12 mm hex	2321422
B	FT.G18M.E12	G1/8" male fitting, 12 mm hex	2321424
C	FT.G18F.E16	G1/8" female fitting, 16 mm hex	2321426
D	FT.G18M.E16	G1/8" male fitting, 16 mm hex	2321428
E	FT.G14F.E16	G1/4" female fitting, 16 mm hex	2321430
F	FT.G14M.E17	G1/4" male fitting, 17 mm hex	2321432

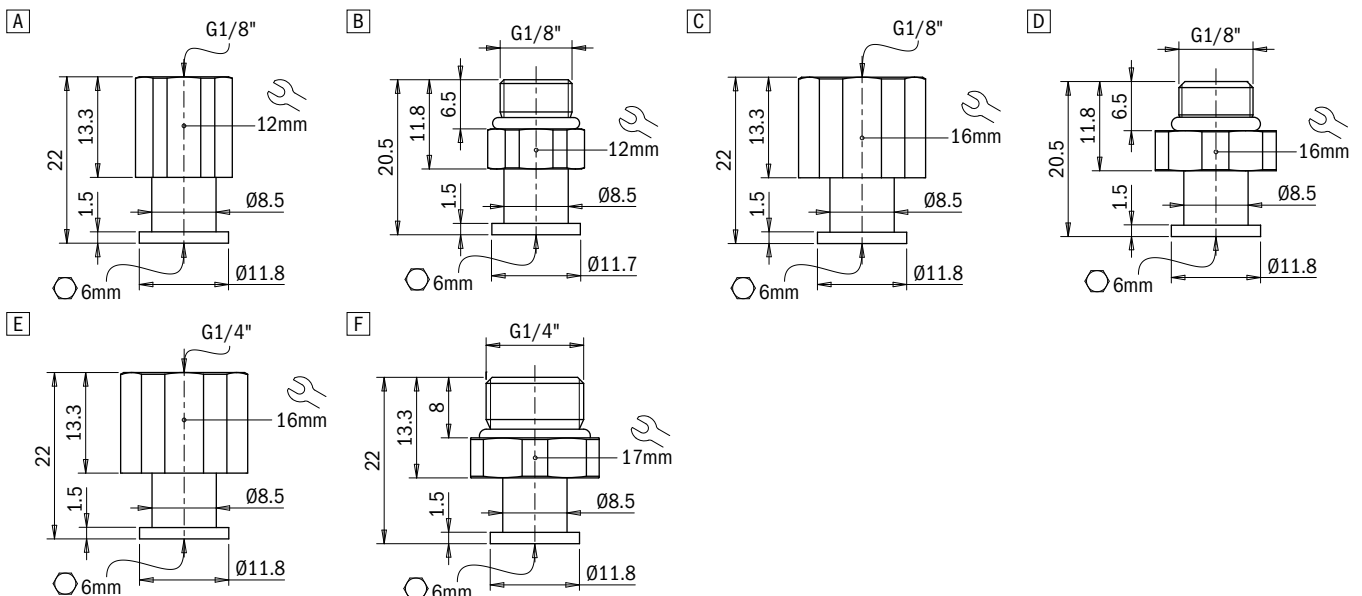

Suction cups / NBR-HNBR

VG.LB42 bellows suction cups in NBR-HNBR

- Suitable for handling plastic parts
- Suitable for objects with flat or slightly curved surfaces
- They enable to compensate for differences in height
- Ideal for leafing through and picking up thin metal sheets, glass sheets, chipboard or pressed wood panels, plastic laminates
- The HNBR version enables to work at high temperatures, whereas silicone or other mixtures may release traces of material. Ideal for applications where contamination of the material must be avoided (PWIS)
- The HNBR compound is robust and wear resistant, suitable for the removal of hot plastic parts from the relevant moulds

Application example

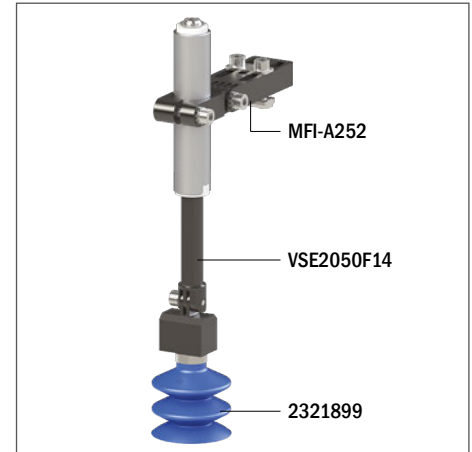

Technical data

Material	Lifting force [N] perpendicular to the surface, at various vacuum levels			Lifting force [N] parallel to the surface, at various vacuum levels			Volume [cm ³]	Min curve radius [mm]	Max vert. movement [mm]	Suction cup weight [g]
	-20 kPa	-60 kPa	-90 kPa	-20 kPa	-60 kPa	-90 kPa				
NBR 50	25.2	70.2	85.5	–	–	–	19	75	20	19.1
HNBR 60	25.2	70.2	85.5	–	–	–	19	75	20	15.5

Technical features

Material	Color	Hardness	Temperature range
NBR	Black	50 Shore	-40 - +212 °F
HNBR	Blue	60 Shore	-13 - +302 °F

Identification codes

Drawing	Alphanumeric code	Suction cups with fitting	Order code
A	VG.LB42N.50.G18F.E12	VG.LB42 suction cup, NBR, 50 Shore, G1/8" female, 12 mm hex	2321886
B	VG.LB42N.50.G18M.E12	VG.LB42 suction cup, NBR, 50 Shore, G1/8" male, 12 mm hex	2321888
C	VG.LB42N.50.G18F.E16	VG.LB42 suction cup, NBR, 50 Shore, G1/8" female, 16 mm hex	2321889
D	VG.LB42N.50.G18M.E16	VG.LB42 suction cup, NBR, 50 Shore, G1/8" male, 16 mm hex	2321890
E	VG.LB42N.50.G14F.E16	VG.LB42 suction cup, NBR, 50 Shore, G1/4" female, 16 mm hex	2321891
F	VG.LB42N.50.G14M.E17	VG.LB42 suction cup, NBR, 50 Shore, G1/4" male, 17 mm hex	2321892
A	VG.LB42H.60.G18F.E12	VG.LB42 suction cup, HNBR, 60 Shore, G1/8" female, 12 mm hex	2321893
B	VG.LB42H.60.G18M.E12	VG.LB42 suction cup, HNBR, 60 Shore, G1/8" male, 12 mm hex	2321895
C	VG.LB42H.60.G18F.E16	VG.LB42 suction cup, HNBR, 60 Shore, G1/8" female, 16 mm hex	2321896
D	VG.LB42H.60.G18M.E16	VG.LB42 suction cup, HNBR, 60 Shore, G1/8" male, 16 mm hex	2321897
E	VG.LB42H.60.G14F.E16	VG.LB42 suction cup, HNBR, 60 Shore, G1/4" female, 16 mm hex	2321898
F	VG.LB42H.60.G14M.E17	VG.LB42 suction cup, HNBR, 60 Shore, G1/4" male, 17 mm hex	2321899

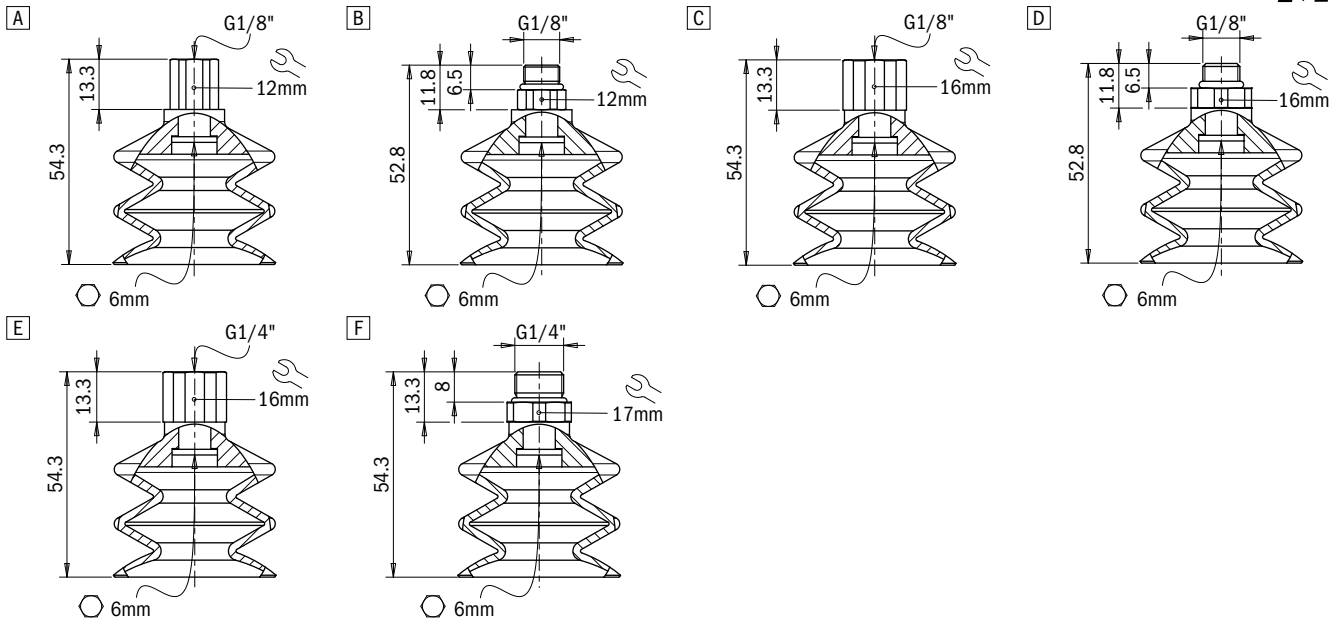

Identification codes

Drawing	Alphanumeric code	Suction cups	Order code
A	VG.LB42N.50	VG.LB42 suction cup, NBR, 50 Shore	2321887
A	VG.LB42H.60	VG.LB42 suction cup, HNBR, 60 Shore	2321894

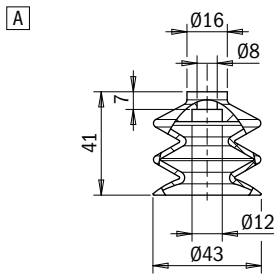

Identification codes

Drawing	Alphanumeric code	Fittings	Order code
A	FT.G18F.E12	G1/8" female fitting, 12 mm hex	2321422
B	FT.G18M.E12	G1/8" male fitting, 12 mm hex	2321424
C	FT.G18F.E16	G1/8" female fitting, 16 mm hex	2321426
D	FT.G18M.E16	G1/8" male fitting, 16 mm hex	2321428
E	FT.G14F.E16	G1/4" female fitting, 16 mm hex	2321430
F	FT.G14M.E17	G1/4" male fitting, 17 mm hex	2321432

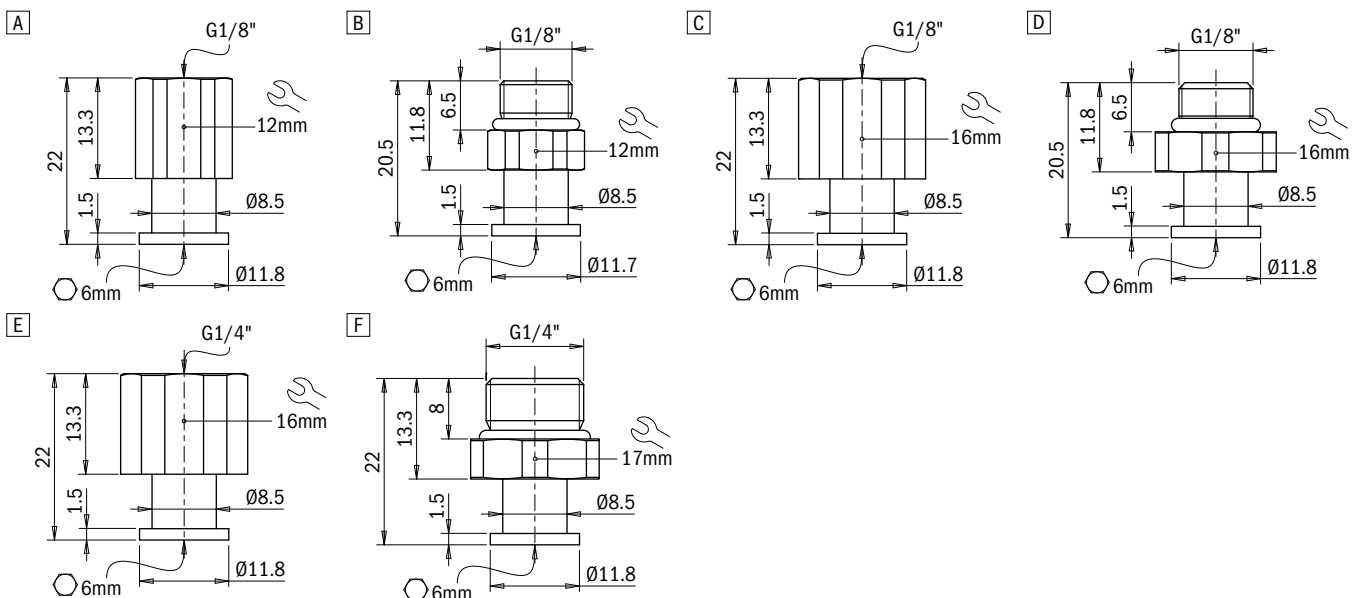

Suction cups / NBR-HNBR

VG.LB53 bellows suction cups in NBR-HNBR

- Suitable for handling plastic parts
- Suitable for objects with flat or slightly curved surfaces
- They enable to compensate for differences in height
- Ideal for leafing through and picking up thin metal sheets, glass sheets, chipboard or pressed wood panels, plastic laminates
- The HNBR version enables to work at high temperatures, whereas silicone or other mixtures may release traces of material. Ideal for applications where contamination of the material must be avoided (PWIS)
- The HNBR compound is robust and wear resistant, suitable for the removal of hot plastic parts from the relevant moulds

Application example

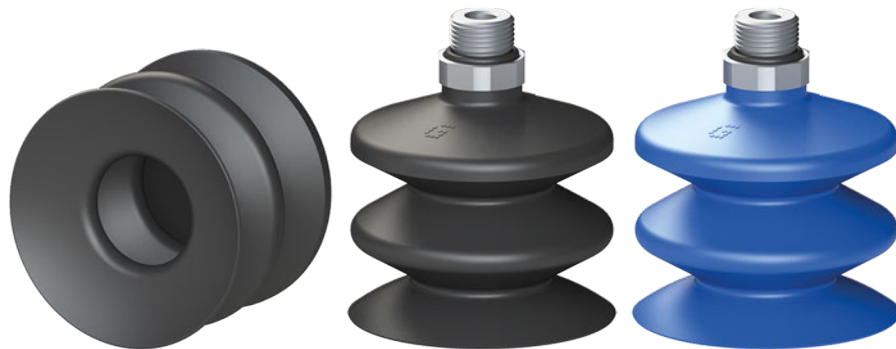
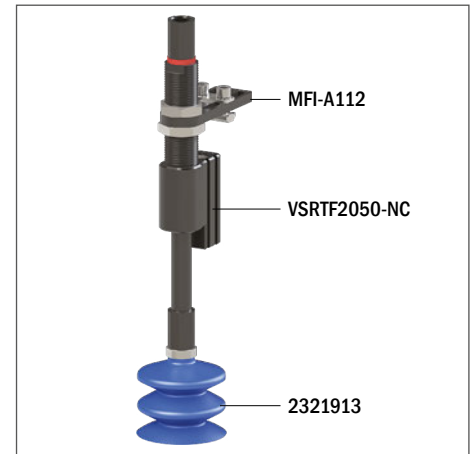

Technical data

Material	Lifting force [N] perpendicular to the surface, at various vacuum levels			Lifting force [N] parallel to the surface, at various vacuum levels			Volume [cm ³]	Min curve radius [mm]	Max vert. movement [mm]	Suction cup weight [g]
	-20 kPa	-60 kPa	-90 kPa	-20 kPa	-60 kPa	-90 kPa				
NBR 50	40.3	102.8	106.7	–	–	–	37	80	25	31.5
HNBR 60	40.3	102.8	106.7	–	–	–	37	80	25	25.6

Technical features

Material	Color	Hardness	Temperature range
NBR	Black	50 Shore	-40 - +212 °F
HNBR	Blue	60 Shore	-13 - +302 °F

Identification codes

Drawing	Alphanumeric code	Suction cups with fitting	Order code
A	VG.LB53N.50.G18F.E12	VG.LB53 suction cup, NBR, 50 Shore, G1/8" female, 12 mm hex	2321900
B	VG.LB53N.50.G18M.E12	VG.LB53 suction cup, NBR, 50 Shore, G1/8" male, 12 mm hex	2321902
C	VG.LB53N.50.G18F.E16	VG.LB53 suction cup, NBR, 50 Shore, G1/8" female, 16 mm hex	2321903
D	VG.LB53N.50.G18M.E16	VG.LB53 suction cup, NBR, 50 Shore, G1/8" male, 16 mm hex	2321904
E	VG.LB53N.50.G14F.E16	VG.LB53 suction cup, NBR, 50 Shore, G1/4" female, 16 mm hex	2321905
F	VG.LB53N.50.G14M.E17	VG.LB53 suction cup, NBR, 50 Shore, G1/4" male, 17 mm hex	2321906
A	VG.LB53H.60.G18F.E12	VG.LB53 suction cup, HNBR, 60 Shore, G1/8" female, 12 mm hex	2321907
B	VG.LB53H.60.G18M.E12	VG.LB53 suction cup, HNBR, 60 Shore, G1/8" male, 12 mm hex	2321909
C	VG.LB53H.60.G18F.E16	VG.LB53 suction cup, HNBR, 60 Shore, G1/8" female, 16 mm hex	2321910
D	VG.LB53H.60.G18M.E16	VG.LB53 suction cup, HNBR, 60 Shore, G1/8" male, 16 mm hex	2321911
E	VG.LB53H.60.G14F.E16	VG.LB53 suction cup, HNBR, 60 Shore, G1/4" female, 16 mm hex	2321912
F	VG.LB53H.60.G14M.E17	VG.LB53 suction cup, HNBR, 60 Shore, G1/4" male, 17 mm hex	2321913

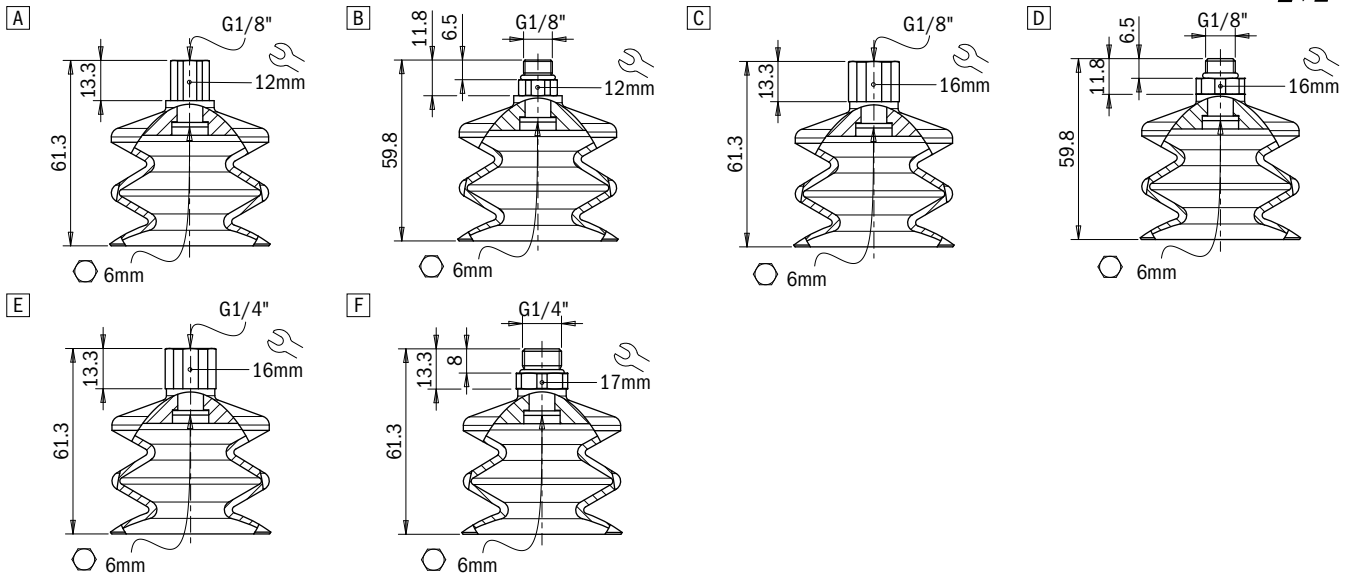

Identification codes

Drawing	Alphanumeric code	Suction cups	Order code
A	VG.LB53N.50	VG.LB53 suction cup, NBR, 50 Shore	2321901
A	VG.LB53H.60	VG.LB53 suction cup, HNBR, 60 Shore	2321908

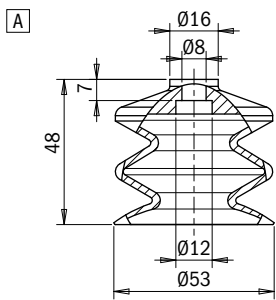

Identification codes

Drawing	Alphanumeric code	Fittings	Order code
A	FT.G18F.E12	G1/8" female fitting, 12 mm hex	2321422
B	FT.G18M.E12	G1/8" male fitting, 12 mm hex	2321424
C	FT.G18F.E16	G1/8" female fitting, 16 mm hex	2321426
D	FT.G18M.E16	G1/8" male fitting, 16 mm hex	2321428
E	FT.G14F.E16	G1/4" female fitting, 16 mm hex	2321430
F	FT.G14M.E17	G1/4" male fitting, 17 mm hex	2321432

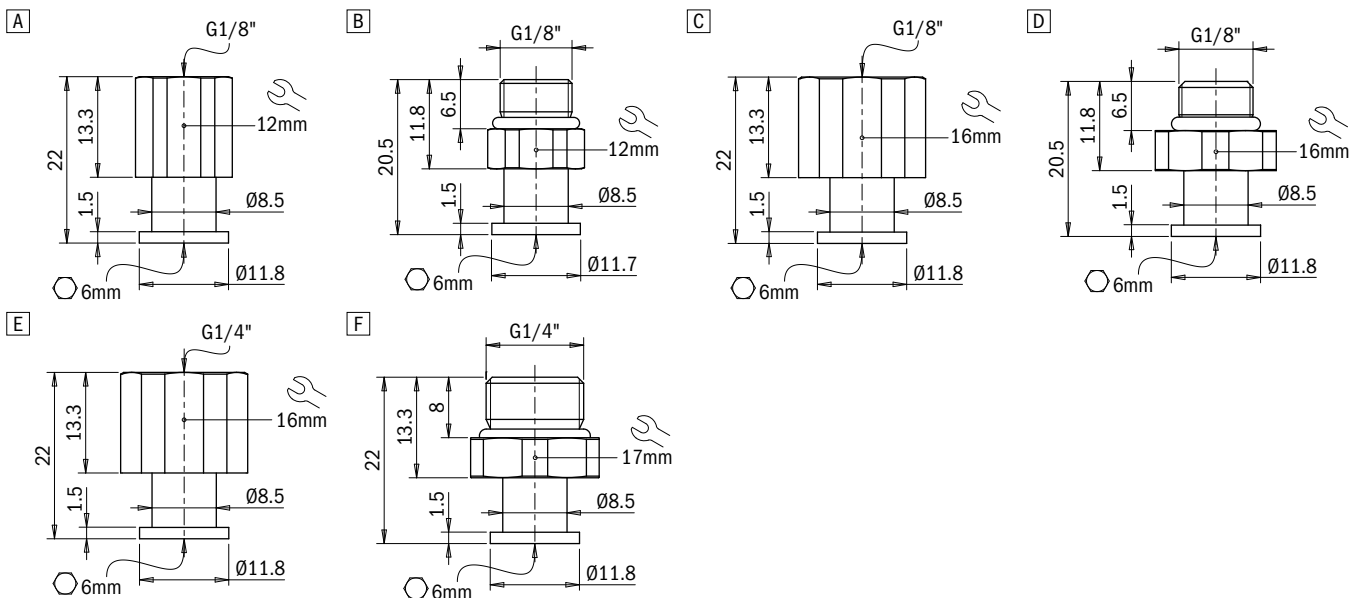

Suction cups / Silicone

VG.FP15S multi-bellows suction cups in silicone

- Ideal for handling packaged snack foods
- Suitable for level compensation
- High vertical movement, useful for separating thin parts

Introduction

Vacuum theory

Suction cups

Vacuum pumps

Customised solutions

Suspensions

System accessories

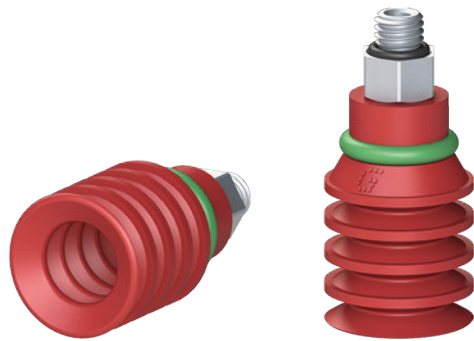

Application example

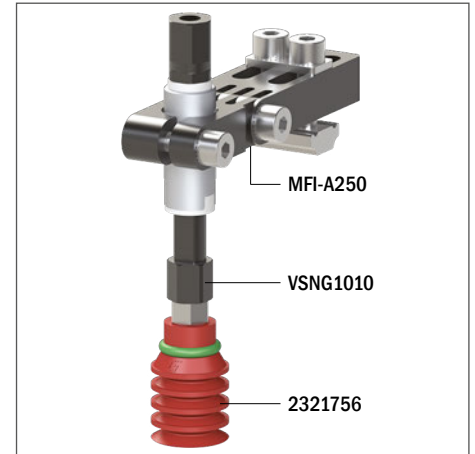

Technical data

Material	Lifting force [N] perpendicular to the surface, at various vacuum levels			Lifting force [N] parallel to the surface, at various vacuum levels			Volume [cm ³]	Min curve radius [mm]	Max vertical movement [mm]	Suction cup weight [g]
	-20 kPa	-60 kPa	-90 kPa	-20 kPa	-60 kPa	-90 kPa				
SIL 50	0.20	0.23	–	–	–	–	1.05	2	8	0.9

Technical features

Material	Color	Hardness	Temperature range
Silicone	Red	50 Shore	-94 - +392 °F

Identification codes			
Drawing	Alphanumeric code	Suction cups with fitting	Order code
A	VG.FP15S.50.M5M	VG.FP15 suction cup, silicone, 50 Shore, M5 male	2321756

A

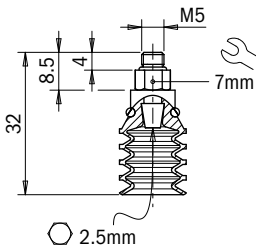

Identification codes			
Drawing	Alphanumeric code	Suction cups	Order code
A	VG.FP15S.50	VG.FP15 suction cup, silicone, 50 Shore	2322052

A

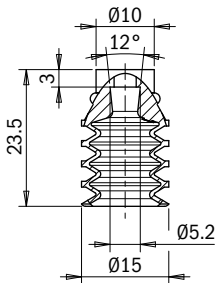

Identification codes			
Drawing	Alphanumeric code	Fittings	Order code
A	FT.M5M	M5 male fitting	1600005

A

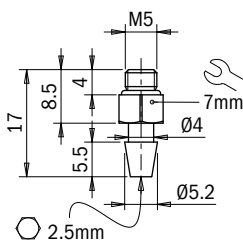

Suction cups / Silicone

VG.FP20S multi-bellows suction cups in silicone

- Ideal for handling packaged snack foods
- Suitable for level compensation
- High vertical movement, useful for separating thin parts
- It can be equipped with a perforated disc to increase stability and to allow the handling of thin films

Application example

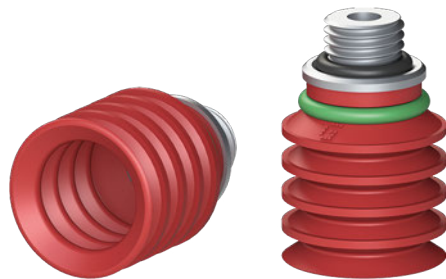
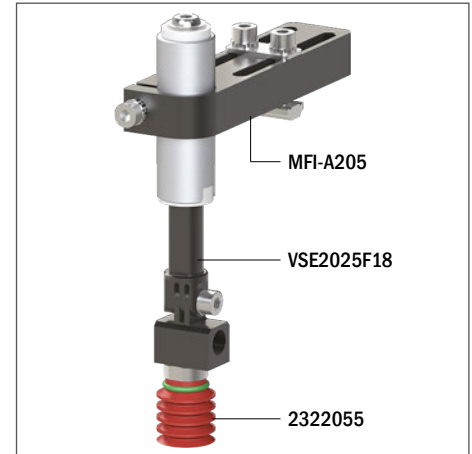

Technical data

Material	Lifting force [N] perpendicular to the surface, at various vacuum levels			Lifting force [N] parallel to the surface, at various vacuum levels			Volume [cm ³]	Min curve radius [mm]	Max vertical movement [mm]	Suction cup weight [g]
	-20 kPa	-60 kPa	-90 kPa	-20 kPa	-60 kPa	-90 kPa				
SIL 50	0.35	0.7	–	–	–	–	4	4	13	3

Technical features

Material	Color	Hardness	Temperature range
Silicone	Red	50 Shore	-94 - +392 °F

Identification codes

Drawing	Alphanumeric code	Suction cups with fitting	Order code
A	VG.FP20S.50.M5F	VG.FP20 suction cup, silicone, 50 Shore, M5 female	2322053
B	VG.FP20S.50.G18M	VG.FP20 suction cup, silicone, 50 Shore, G1/8" male	2322055
C	VG.FP20S.50.G18MF	VG.FP20 suction cup, silicone, 50 Shore, G1/8" male/M5 female	2322056
D	VG.FP20S.50.G18MFV	VG.FP20 suction cup, silicone, 50 Shore, G1/8" male/M5 female with valve	2322057

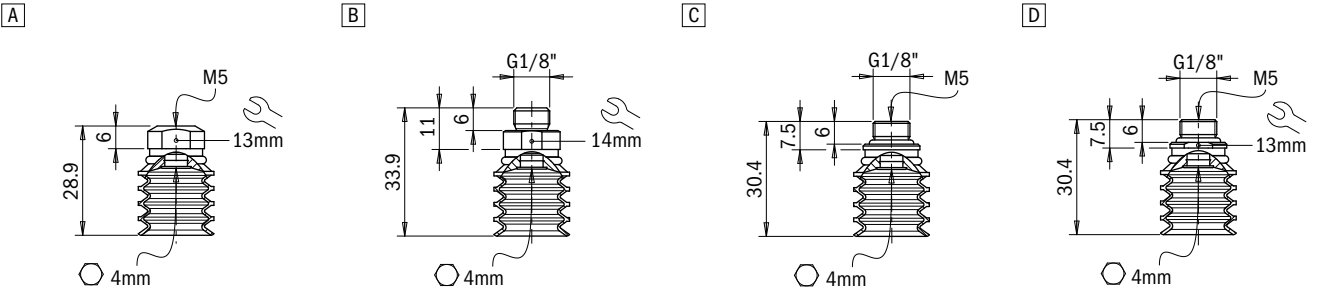

Identification codes

Drawing	Alphanumeric code	Suction cups	Order code
A	VG.FP20S.50	VG.FP20 suction cup, silicone, 50 Shore	2322054

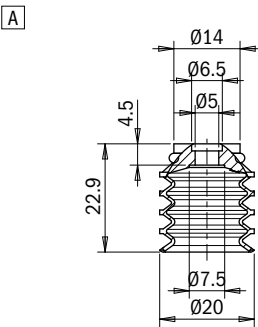

Identification codes

Drawing	Alphanumeric code	Fittings	Order code
A	FT.M5F	Fitting, M5 female	1700006
B	FT.G18M.17	G1/8" male fitting	1700018
C	FT.G18M.M5F	Fitting, G1/8" male/ M5 female	1700016
D	FT.G18M.M5F.VF	G1/8" male / M5 female fitting, with valve	1700017

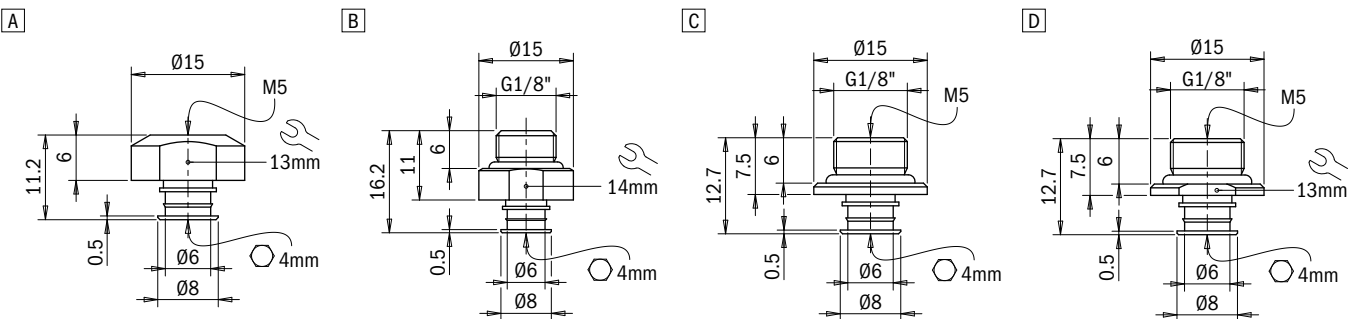

Identification codes

Alphanumeric code	Disc	Order code
AC.DF20	Perforated disc for thin films, diameter 20 mm	2321780

Suction cups / Silicone

VG.FP30S multi-bellows suction cups in silicone

- Ideal for handling packaged snack foods
- Suitable for level compensation
- High vertical movement, useful for separating thin parts
- It can be equipped with a perforated disc to increase stability and to allow the handling of thin films

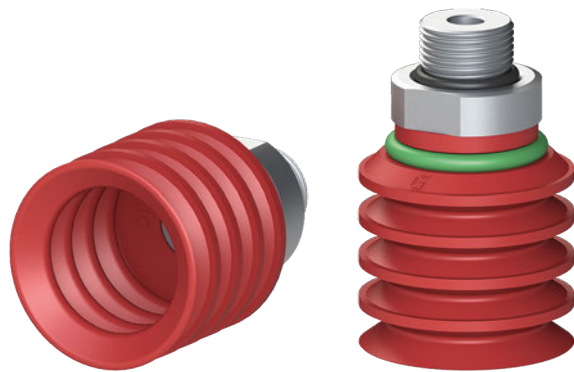

Application example

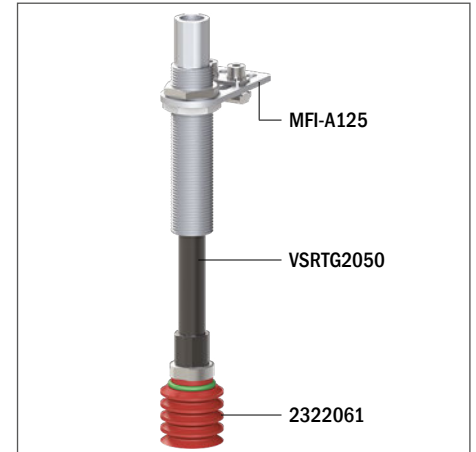

Technical data

Material	Lifting force [N] perpendicular to the surface, at various vacuum levels			Lifting force [N] parallel to the surface, at various vacuum levels			Volume [cm ³]	Min curve radius [mm]	Max vertical movement [mm]	Suction cup weight [g]
	-20 kPa	-60 kPa	-90 kPa	-20 kPa	-60 kPa	-90 kPa				
SIL 50	6.5	10.3	–	–	–	–	10	8	20	7

Technical features

Material	Color	Hardness	Temperature range
Silicone	Red	50 Shore	-94 - +392 °F

Identification codes

Drawing	Alphanumeric code	Suction cups with fitting	Order code
A	VG.FP30S.50.G18F	VG.FP30 suction cup, silicone, 50 Shore, G1/8" female	2322058
B	VG.FP30S.50.G18M	VG.FP30 suction cup, silicone, 50 Shore, G1/8" male	2322060
C	VG.FP30S.50.G14M	VG.FP30 suction cup, silicone, 50 Shore, G1/4" male	2322061
D	VG.FP30S.50.G38M	VG.FP30 suction cup, silicone, 50 Shore, G3/8" male	2322062

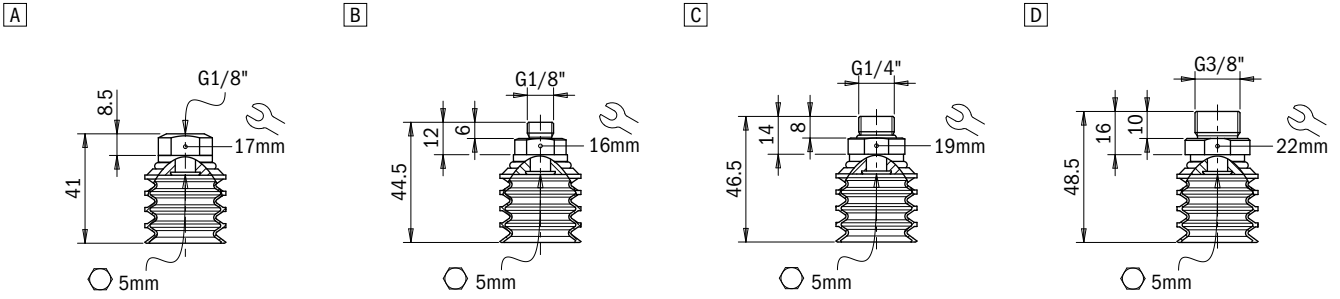

Identification codes

Drawing	Alphanumeric code	Suction cups	Order code
A	VG.FP30S.50	VG.FP30 suction cup, silicone, 50 Shore	2322059

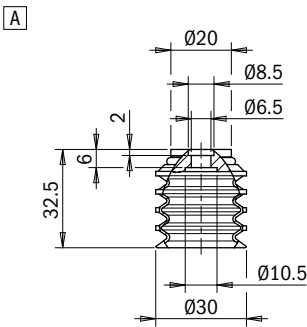

Identification codes

Drawing	Alphanumeric code	Fittings	Order code
A	FT.G18F.18	G1/8" female fitting	1800019
B	FT.G18M.18	G1/8" male fitting	1800018
C	FT.G14M.18	G1/4" male fitting	1800014
D	FT.G38M.18	G3/8" male fitting	1800038

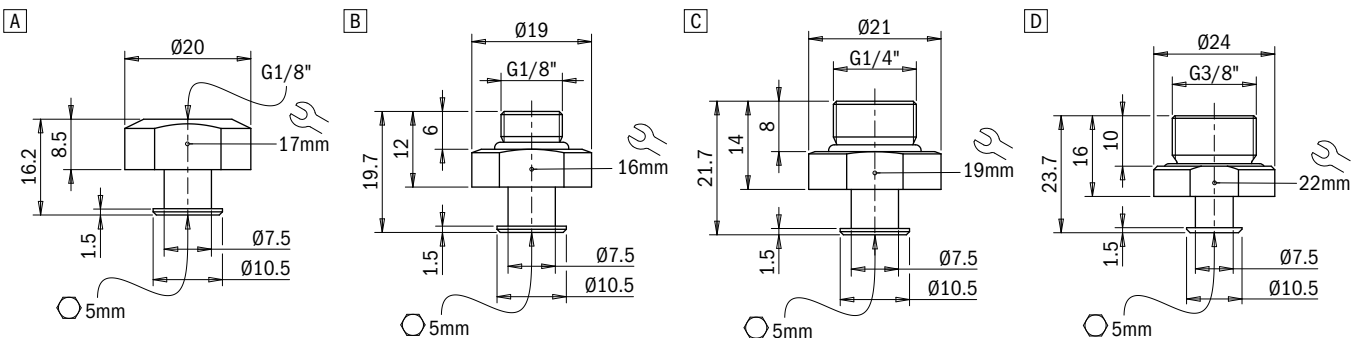

Identification codes

Alphanumeric code	Disc	Order code
AC.DF30	Perforated disc for thin films, diameter 30 mm	2321781

Suction cups / Silicone

VG.FP40S multi-bellows suction cups in silicone

- Ideal for handling packaged snack foods
- Suitable for level compensation
- High vertical movement, useful for separating thin parts
- It can be equipped with a perforated disc to increase stability and to allow the handling of thin films

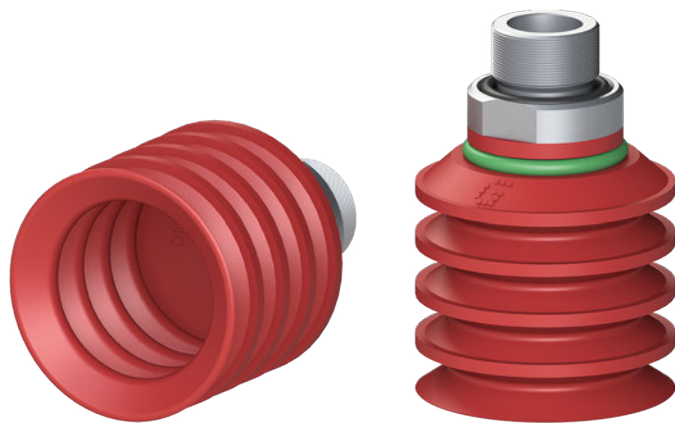

Application example



Technical data

Material	Lifting force [N] perpendicular to the surface, at various vacuum levels			Lifting force [N] parallel to the surface, at various vacuum levels			Volume [cm ³]	Min curve radius [mm]	Max vertical movement [mm]	Suction cup weight [g]
	-20 kPa	-60 kPa	-90 kPa	-20 kPa	-60 kPa	-90 kPa				
SIL 50	10.8	31.5	–	–	–	–	27	11	33	10

Technical features

Material	Color	Hardness	Temperature range
Silicone	Red	50 Shore	-94 - +392 °F

Identification codes

Drawing	Alphanumeric code	Suction cups with fitting	Order code
A	VG.FP40S.50.G18F	VG.FP40 suction cup, silicone, 50 Shore, G1/8" female	2322063
B	VG.FP40S.50.G18M	VG.FP40 suction cup, silicone, 50 Shore, G1/8" male	2322065
C	VG.FP40S.50.G14M	VG.FP40 suction cup, silicone, 50 Shore, G1/4" male	2322066
D	VG.FP40S.50.G38M	VG.FP40 suction cup, silicone, 50 Shore, G3/8" male	2322067

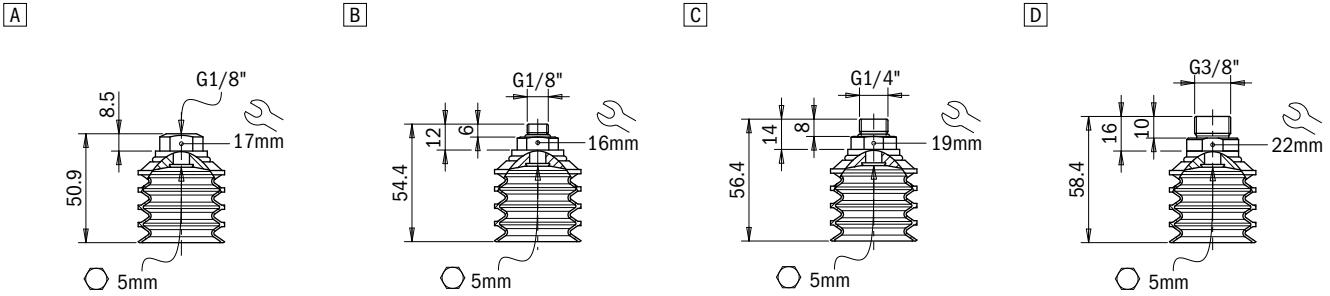

Identification codes

Drawing	Alphanumeric code	Suction cups	Order code
A	VG.FP40S.50	VG.FP40 suction cup, silicone, 50 Shore	2322064

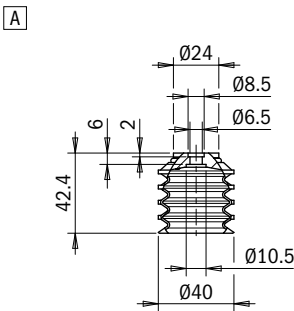

Identification codes

Drawing	Alphanumeric code	Fittings	Order code
A	FT.G18F.18	G1/8" female fitting	1800019
B	FT.G18M.18	G1/8" male fitting	1800018
C	FT.G14M.18	G1/4" male fitting	1800014
D	FT.G38M.18	G3/8" male fitting	1800038

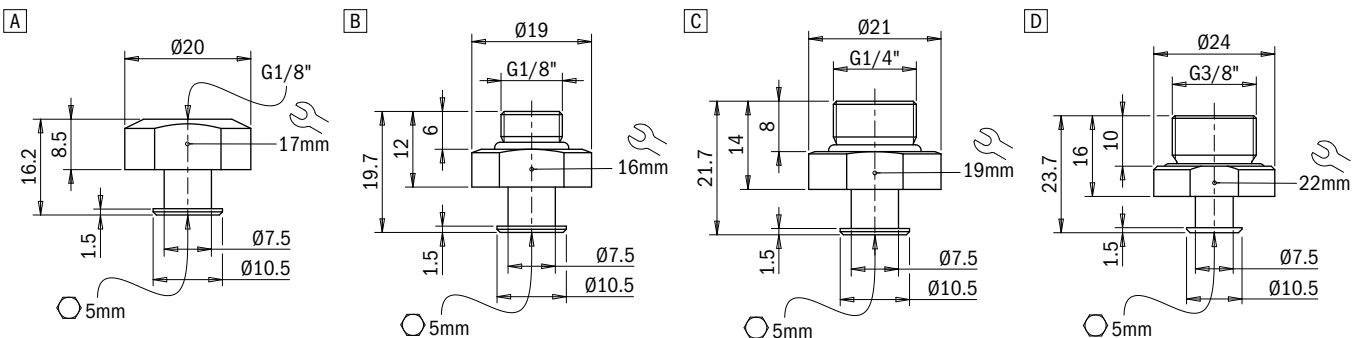

Identification codes

Alphanumeric code	Disc	Order code
AC.DF40	Perforated disc for thin films, diameter 40 mm	2321755

Suction cups / Silicone

VG.SBC40S multibellows suction cups in silicone

- Ideal for handling bags containing fragile products and bags with liquids and frozen foods
- Strong bellows, soft and flexible lip and special high flow rate fittings
- Version with 2.5 bellows
- High stability in very fast packaging processes (case packer and Pick & Place applications)

Application example

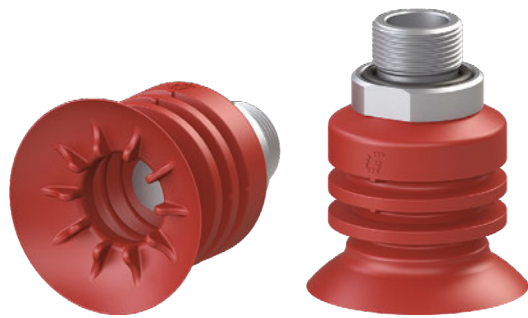

Technical data

Material	Lifting force [N] perpendicular to the surface, at various vacuum levels		Volume [cm ³]	Min curve radius [mm]	Max vert. movement [mm]	Suction cup weight [g]
	-20 kPa	-60 kPa				
SIL 40	14.5	17.5	11	22	13	12.5

Technical features

Material	Color	Hardness	Temperature range
Silicone 40	Red	40 Shore	-94 - +392 °F

Identification codes

Drawing	Alphanumeric code	Suction cups with fitting	Order code
A	VG.SBC40S.40.G38M	VG.SBC40 suction cup, silicone, 40 Shore, G3/8" male	1322143



Click for Pricing & Add to Cart

A

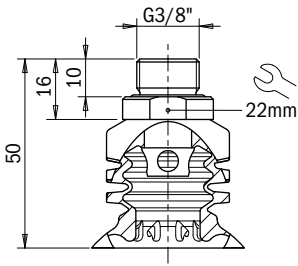

Identification codes

Drawing	Alphanumeric code	Suction cups	Order code
A	VG.SBC40S.40	VG.SBC40 suction cup, silicone, 40 Shore	1322144

A

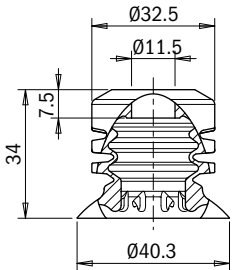

Identification codes

Drawing	Alphanumeric code	Fittings	Order code
A	FT.G38M	G3/8" male fitting	2000038

A

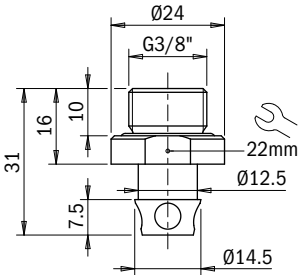

Introduction

Vacuum theory

Suction cups

Vacuum pumps

Customised solutions

Suspensions

System accessories

Suction cups / Silicone

VG.SBC50S multibellows suction cups in silicone

- Ideal for handling bags containing fragile products and bags with liquids and frozen foods
- Strong bellows, soft and flexible lip and special high flow rate fittings
- Version with 2.5 bellows
- High stability in very fast packaging processes (case packer and Pick & Place applications)

Application example

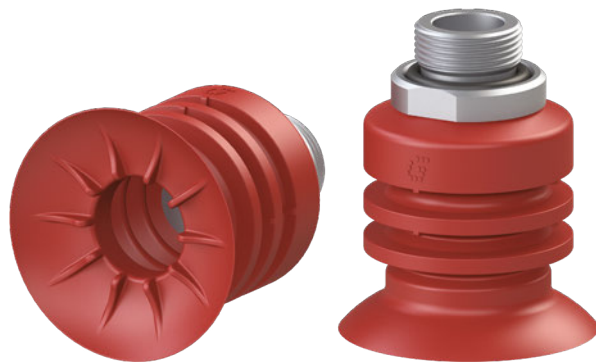
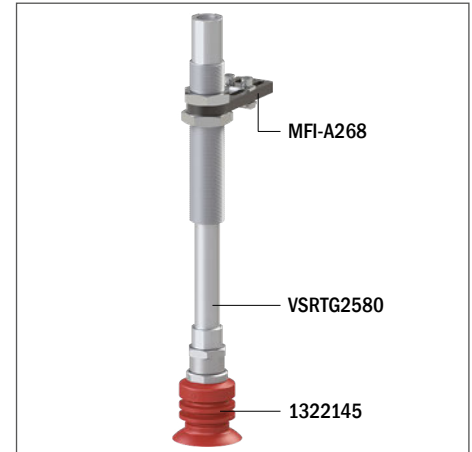

Technical data

Material	Lifting force [N] perpendicular to the surface, at various vacuum levels		Volume [cm ³]	Min curve radius [mm]	Max vert. movement [mm]	Suction cup weight [g]
	-20 kPa	-60 kPa				
SIL 40	24.7	30.5	24	30	14	25

Technical features

Material	Color	Hardness	Temperature range
Silicone 40	Red	40 Shore	-94 - +392 °F

Identification codes

Drawing	Alphanumeric code	Suction cups with fitting	Order code
A	VG.SBC50S.40.G12M	VG.SBC50 suction cup, silicone, 40 Shore, G1/2" male	1322145

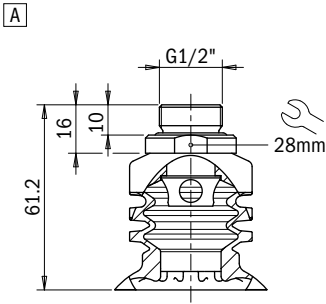

Identification codes

Drawing	Alphanumeric code	Suction cups	Order code
A	VG.SBC50S.40	VG.SBC50 suction cup, silicone, 40 Shore	1322146

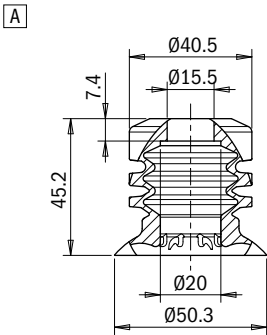

Identification codes

Drawing	Alphanumeric code	Fittings	Order code
A	FT.G12M	G1/2" male fitting	2000012

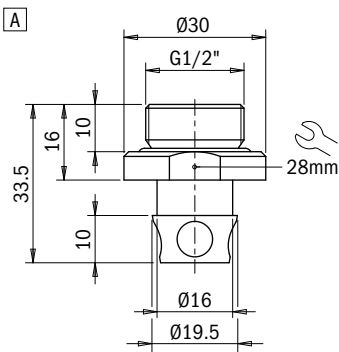

Suction cups / Silicone

VG.SBC63S multibellows suction cups in silicone

- Ideal for handling bags containing fragile products and bags with liquids and frozen foods
- Strong bellows, soft and flexible lip and special high flow rate fittings
- Version with 2.5 bellows
- High stability in very fast packaging processes (case packer and Pick & Place applications)

Application example

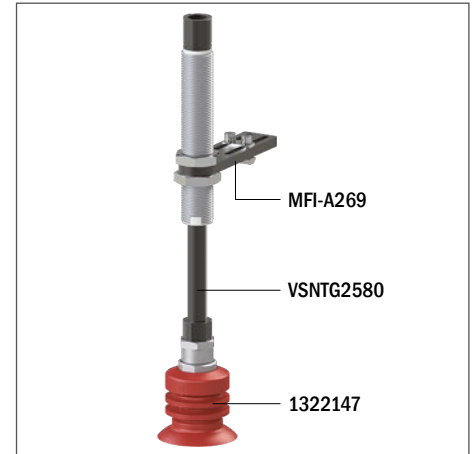

Technical data

Material	Lifting force [N] perpendicular to the surface, at various vacuum levels		Volume [cm ³]	Min curve radius [mm]	Max vert. movement [mm]	Suction cup weight [g]
	-20 kPa	-60 kPa				
SIL 40	42.6	53.2	46.5	40	19	50

Technical features

Material	Color	Hardness	Temperature range
Silicone 40	Red	40 Shore	-94 - +392 °F

Identification codes

Drawing	Alphanumeric code	Suction cups with fitting	Order code
A	VG.SBC63S.40.G12M	VG.SBC63 suction cup, silicone, 40 Shore, G1/2" male	1322147

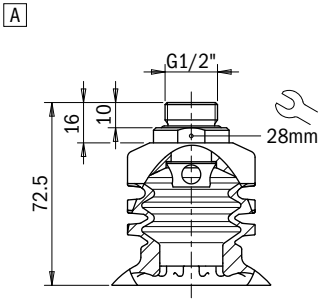

Identification codes

Drawing	Alphanumeric code	Suction cups	Order code
A	VG.SBC63S.40	VG.SBC63 suction cup, silicone, 40 Shore	1322148

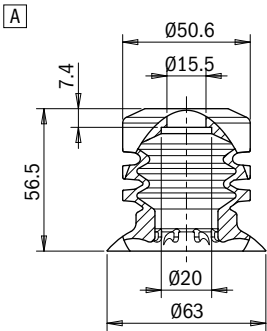

Identification codes

Drawing	Alphanumeric code	Fittings	Order code
A	FT.G12M	G1/2" male fitting	2000012

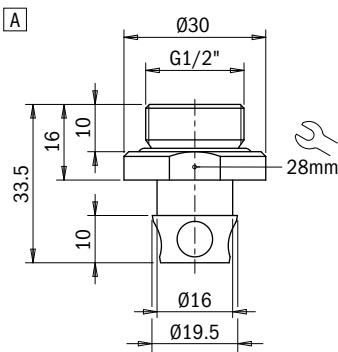

Suction cups / Silicone

VG.BC40S multi-bellows suction cups in silicone

- Ideal for handling bags containing fragile products and bags with liquids and frozen foods
- Strong bellows, soft and flexible lip and special high flow rate fittings
- Version with 4.5 bellows
- They enable to compensate for level differences



Application example



Technical data

Material	Lifting force [N] perpendicular to the surface, at various vacuum levels		Volume [cm ³]	Min curve radius [mm]	Max vertical movement [mm]	Suction cup weight [g]
	-20 kPa	-60 kPa				
SIL 40	14.4	15.3	14	22	20	10

Technical features

Material	Color	Hardness	Temperature range
Silicone 40	Red	40 Shore	-94 - +392 °F

Identification codes			
Drawing	Alphanumeric code	Suction cups with fitting	Order code
A	VG.BC40S.40.G38M	VG.BC40 suction cup, silicone, 40 Shore, G3/8" male	2322143

A

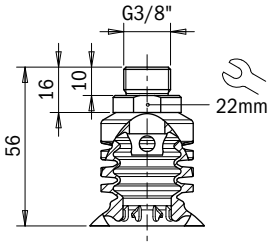

Identification codes			
Drawing	Alphanumeric code	Suction cups	Order code
A	VG.BC40S.40	VG.BC40 suction cup, silicone, 40 Shore	2322144

A

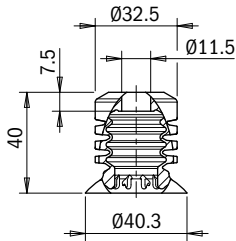

Identification codes			
Drawing	Alphanumeric code	Fittings	Order code
A	FT.G38M.20	G3/8" male fitting	2000038

A

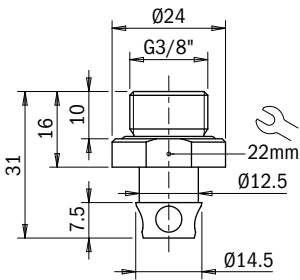

Suction cups / Silicone

VG.BC50S multi-bellows suction cups in silicone

- Ideal for handling bags containing fragile products and bags with liquids and frozen foods
- Strong bellows, soft and flexible lip and special high flow rate fittings
- Version with 4.5 bellows
- They enable to compensate for level differences

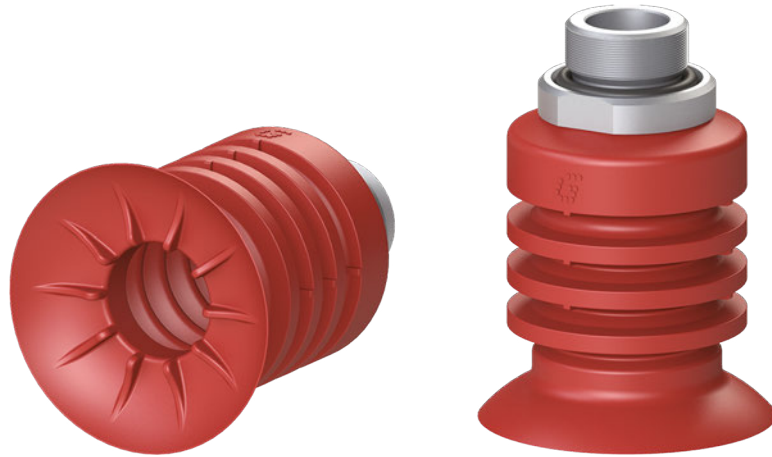

Application example

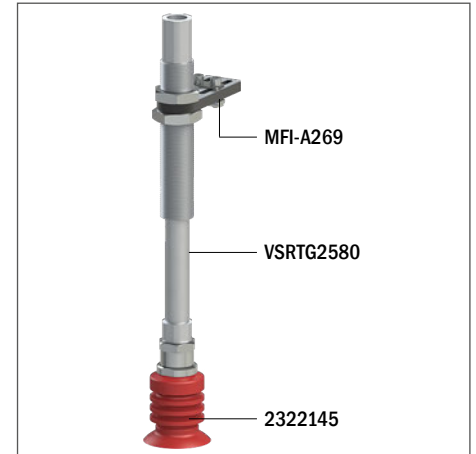

Technical data

Material	Lifting force [N] perpendicular to the surface, at various vacuum levels		Volume [cm ³]	Min curve radius [mm]	Max vertical movement [mm]	Suction cup weight [g]
	-20 kPa	-60 kPa				
SIL 40	26.3	28.2	26	30	18	29

Technical features

Material	Color	Hardness	Temperature range
Silicone 40	Red	40 Shore	-94 - +392 °F

Identification codes			
Drawing	Alphanumeric code	Suction cups with fitting	Order code
A	VG.BC50S.40.G12M	VG.BC50 suction cup, silicone, 40 Shore, G1/2" male	2322145

A

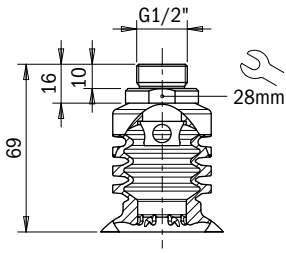

Identification codes			
Drawing	Alphanumeric code	Suction cups	Order code
A	VG.BC50S.40	VG.BC50 suction cup, silicone, 40 Shore	2322146

A

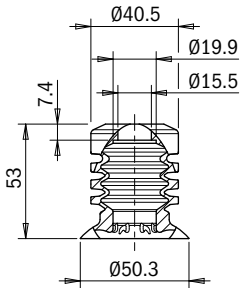

Identification codes			
Drawing	Alphanumeric code	Fittings	Order code
A	FT.G12M.20	G1/2" male fitting	2000012

A

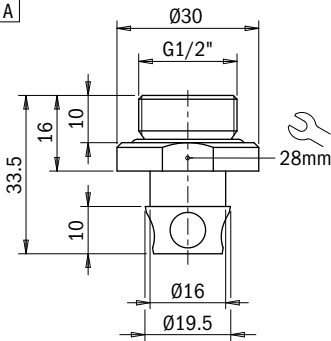

Suction cups / NBR

VG.MB52 bellows suction cup with non-slip cleats in NBR

- Ideal for handling oiled sheet metal in stamping processes
- Handling of flat glass and shaped glass
- Special cleats that increase friction on lubricated surfaces
- Ideal for applications where contamination of the material must be avoided (PWIS)
- Bellows suction cups in NBR, 60 Shore, with vulcanised fitting
- Internal supports help to prevent deformation of thin sheet metal
- Suitable for handling flat and slightly curved surfaces thanks to the wide lip

Application example

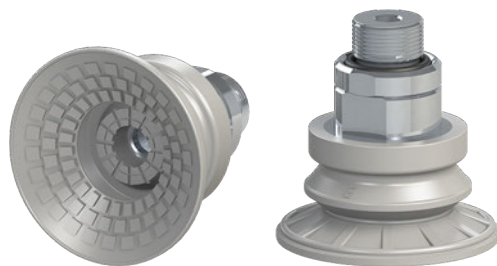
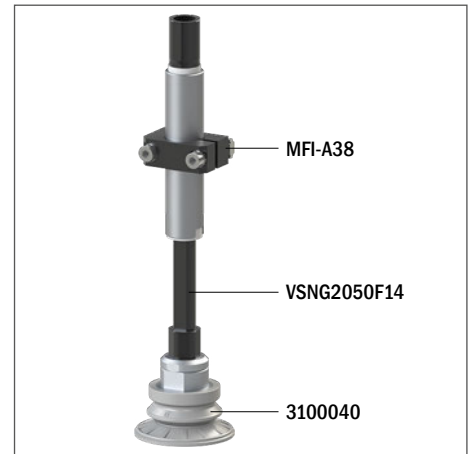

Technical data

Material	Lifting force [N] perpendicular to the surface, at various vacuum levels			Lifting force [N] parallel to the surface, at various vacuum levels			Volume [cm ³]	Min curve radius [mm]	Max vert. movement [mm]	Suction cup weight [g]
	-20 kPa	-60 kPa	-90 kPa	-20 kPa	-60 kPa	-90 kPa				
NBR 60	39.1	103.5	139.5	27.3	89.5	120.5	18	29.5	11	28

Technical features

Material	Color	Hardness	Temperature range
NBR 60	Grey	60 Shore	-22 - +212 °F

Identification codes

Drawing	Alphanumeric code	Suction cups with fitting	Ordering code
A	VG.MB52.60.G14M	VG.MB52 suction cup, NBR, 60 Shore, G1/4" male	3100040
B	VG.MB52.60.G14F	VG.MB52 suction cup, NBR, 60 Shore, G1/4" female	3100041
C	VG.MB52.60.G38M	VG.MB52 suction cup, NBR, 60 Shore, G3/8" male	3100042
D	VG.MB52.60.G38F	VG.MB52 suction cup, NBR, 60 Shore, G3/8" female	3100043

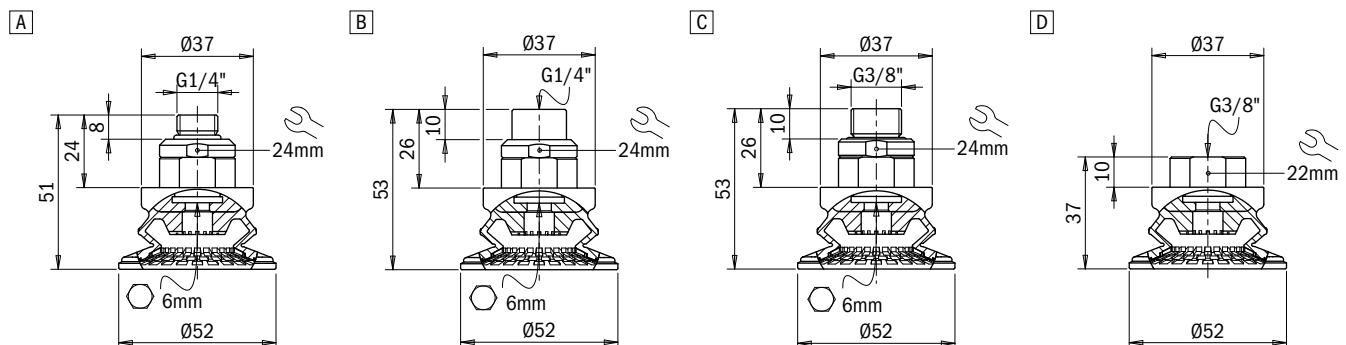

VG.MB63 bellows suction cup with non-slip cleats in NBR

- Ideal for handling oiled sheet metal in stamping processes
- Handling of flat glass and shaped glass
- Special cleats that increase friction on lubricated surfaces
- Ideal for applications where contamination of the material must be avoided (PWIS)
- Bellows suction cups in NBR, 60 Shore, with vulcanised fitting
- Internal supports help to prevent deformation of thin sheet metal
- Suitable for handling flat and slightly curved surfaces thanks to the wide lip

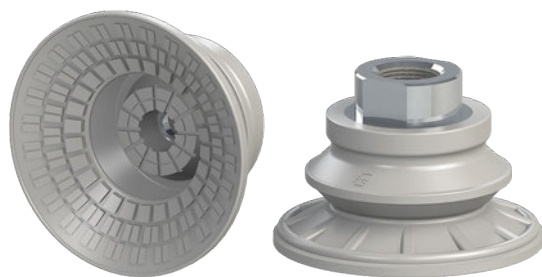

Application example

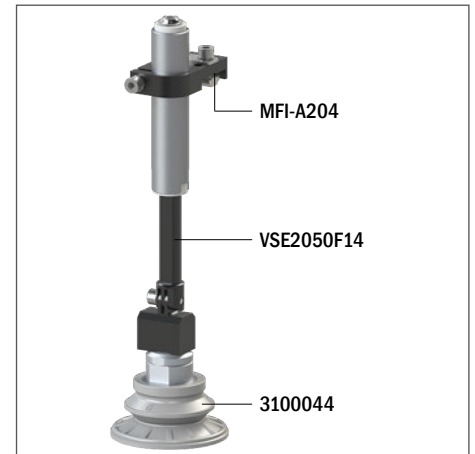

Technical data

Material	Lifting force [N] perpendicular to the surface, at various vacuum levels			Lifting force [N] parallel to the surface, at various vacuum levels			Volume [cm ³]	Min curve radius [mm]	Max vert. movement [mm]	Suction cup weight [g]
	-20 kPa	-60 kPa	-90 kPa	-20 kPa	-60 kPa	-90 kPa				
NBR 60	60.2	149.5	190.5	63.5	156.5	202	30.5	40	14	41

Technical features

Material	Color	Hardness	Temperature range
NBR 60	Grey	60 Shore	-22 - +212 °F

Identification codes

Drawing	Alphanumeric code	Suction cups with fitting	Ordering code
A	VG.MB63.60.G14M	VG.MB63 suction cup, NBR, 60 Shore, G1/4" male	3100044
B	VG.MB63.60.G14F	VG.MB63 suction cup, NBR, 60 Shore, G1/4" female	3100045
C	VG.MB63.60.G38M	VG.MB63 suction cup, NBR, 60 Shore, G3/8" male	3100046
D	VG.MB63.60.G38F	VG.MB63 suction cup, NBR, 60 Shore, G3/8" female	3100047

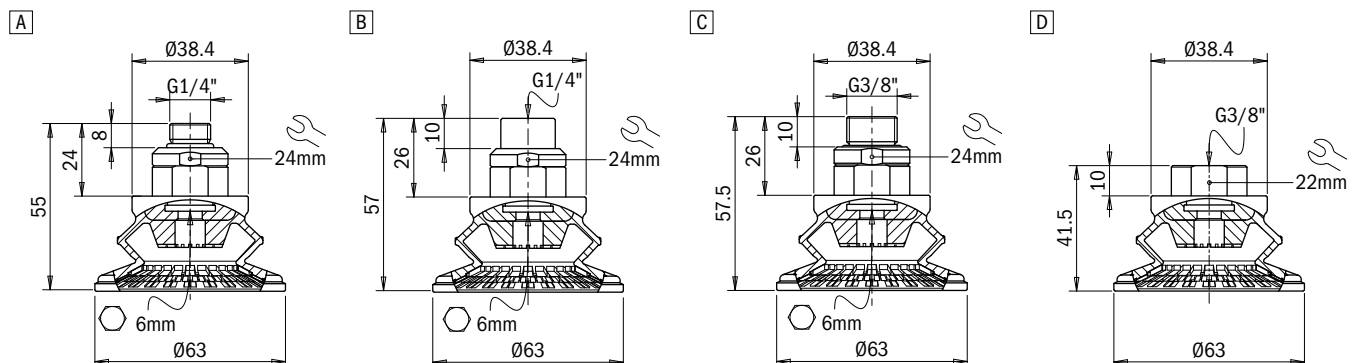

Suction cups / NBR

VG.MB83 bellows suction cup with non-slip cleats in NBR

- Ideal for handling oiled sheet metal in stamping processes
- Handling of flat glass and shaped glass
- Special cleats that increase friction on lubricated surfaces
- Ideal for applications where contamination of the material must be avoided (PWIS)
- Bellows suction cups in NBR, 60 Shore, with vulcanised fitting
- Internal supports help to prevent deformation of thin sheet metal
- Suitable for handling flat and slightly curved surfaces thanks to the wide lip

Application example



Technical data

Material	Lifting force [N] perpendicular to the surface, at various vacuum levels			Lifting force [N] parallel to the surface, at various vacuum levels			Volume [cm ³]	Min curve radius [mm]	Max vert. movement [mm]	Suction cup weight [g]
	-20 kPa	-60 kPa	-90 kPa	-20 kPa	-60 kPa	-90 kPa				
NBR 60	105	239.5	312	107.5	242.5	318.5	67	45	21.5	59.5

Technical features

Material	Color	Hardness	Temperature range
NBR 60	Grey	60 Shore	-22 - +212 °F

Identification codes

Drawing	Alphanumeric code	Suction cups with fitting	Ordering code
A	VG.MB83.60.G14M	VG.MB83 suction cup, NBR, 60 Shore, G1/4" male	3100048
B	VG.MB83.60.G14F	VG.MB83 suction cup, NBR, 60 Shore, G1/4" female	3100049
C	VG.MB83.60.G38M	VG.MB83 suction cup, NBR, 60 Shore, G3/8" male	3100050
D	VG.MB83.60.G38F	VG.MB83 suction cup, NBR, 60 Shore, G3/8" female	3100051

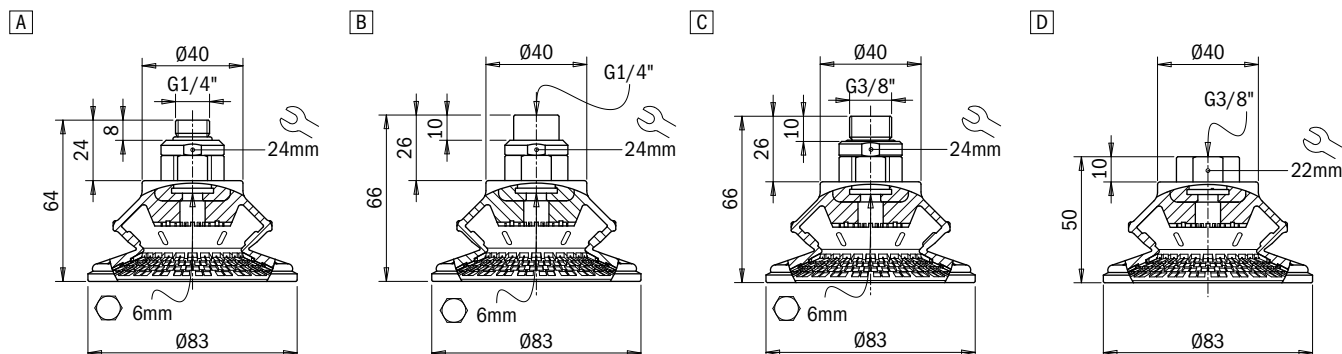

VG.MB103 bellows suction cup with non-slip cleats in NBR

- Ideal for handling oiled sheet metal in stamping processes
- Handling of flat glass and shaped glass
- Special cleats that increase friction on lubricated surfaces
- Ideal for applications where contamination of the material must be avoided (PWIS)
- Bellows suction cups in NBR, 60 Shore, with vulcanised fitting
- Internal supports help to prevent deformation of thin sheet metal
- Suitable for handling flat and slightly curved surfaces thanks to the wide lip



Application example



Technical data

Material	Lifting force [N] perpendicular to the surface, at various vacuum levels			Lifting force [N] parallel to the surface, at various vacuum levels			Volume [cm ³]	Min curve radius [mm]	Max vert. movement [mm]	Suction cup weight [g]
	-20 kPa	-60 kPa	-90 kPa	-20 kPa	-60 kPa	-90 kPa				
NBR 60	160	325	405	163	330	408	108	63	23	85.5

Technical features

Material	Color	Hardness	Temperature range
NBR 60	Grey	60 Shore	-22 - +212 °F

Identification codes

Drawing	Alphanumeric code	Suction cups with fitting	Ordering code
A	VG.MB103.60.G14M	VG.MB103 suction cup, NBR, 60 Shore, G1/4" male	3100052
B	VG.MB103.60.G14F	VG.MB103 suction cup, NBR, 60 Shore, G1/4" female	3100053
C	VG.MB103.60.G38M	VG.MB103 suction cup, NBR, 60 Shore, G3/8" male	3100054
D	VG.MB103.60.G38F	VG.MB103 suction cup, NBR, 60 Shore, G3/8" female	3100055

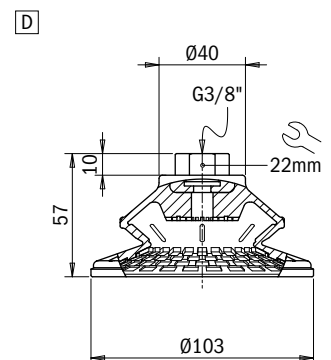
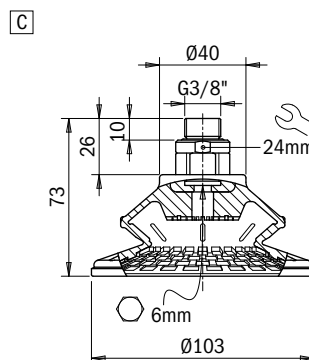
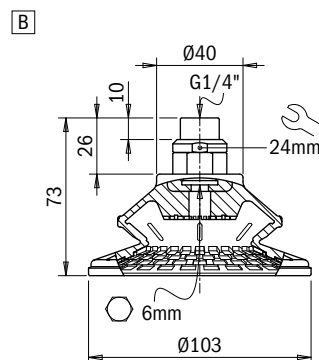
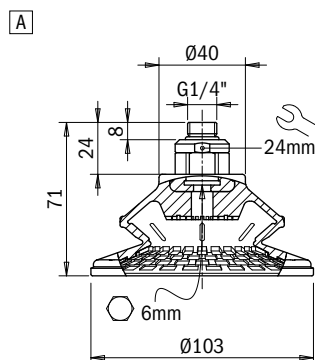

Suction cups / PTFE

VG.PAAT flat PTFE suction cups, 16 - 20 - 30 - 40

- Suction cup in PTFE
- Silicone compensator
- Stainless steel fitting
- Suitable for high working temperatures up to 300 °C
- PTFE does not stick to polymers or hot fibres
- The elastic suspension allows axial and angular movements



Application example

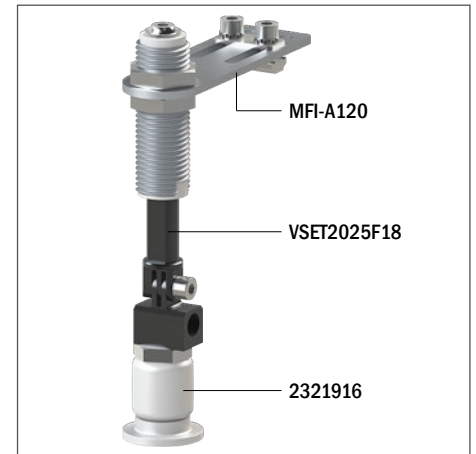

Technical data

Material	Lifting force [N] perpendicular to the surface, at various vacuum levels			Suction cup weight [g]
	-20 kPa	-60 kPa	-90 kPa	
PAAT16R - PTFE	–	6	8	9
PAAT20R - PTFE	–	8.2	13	9
PAAT30R - PTFE	–	9	14	37
PAAT40R - PTFE	–	9.6	15	37

Technical features

Material	Color	Temperature range
PTFE	White	-4 - +572 °F

Identification codes

Drawing	Alphanumeric code	Suction cups with fitting	Order code
A	VG.PAAT.16R	VG.PAAT.16R PTFE suction cup, M5 male	2321914
B	VG.PAAT.20R	VG.PAAT.20R PTFE suction cup, M5 male	2321915
C	VG.PAAT.30R	VG.PAAT.30R PTFE suction cup, G1/8" male	2321916
D	VG.PAAT.40R	VG.PAAT.40R PTFE suction cup, G1/8" male	2321917

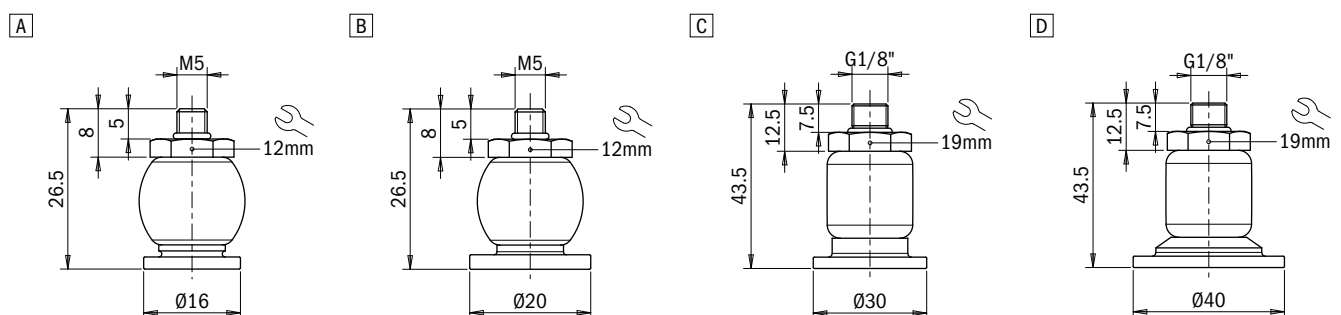

Suction cups / Polyurethane

VG.IS20P bellows suction cups in polyurethane

- Ideal to handle uneven and rough surfaces
- High flexibility: the wide yet thin lip allows for adaptation to uneven surfaces
- Polyurethane material with double hardness, 30/60 Shore
- Good resistance to wear

Application example

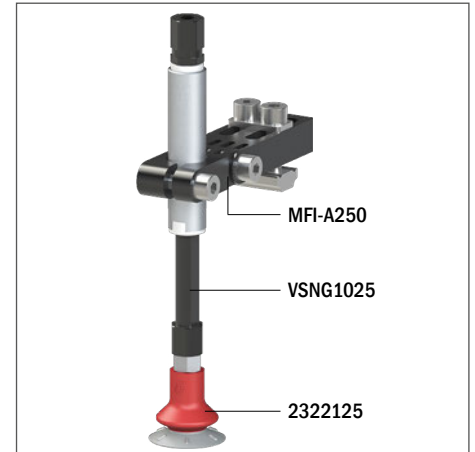

Technical data

Material	Lifting force [N] perpendicular to the surface, at various vacuum levels			Lifting force [N] parallel to the surface, at various vacuum levels			Volume [cm ³]	Min curve radius [mm]	Max vertical movement [mm]	Suction cup weight [g]
	-20 kPa	-60 kPa	-90 kPa	-20 kPa	-60 kPa	-90 kPa				
PU30/60	3.7	8.4	9.9	3.2	6.2	9.1	1.04	5.5	4.6	1.2

Technical features

Material	Color	Hardness	Temperature range
Polyurethane PU, 30/60 Shore	Grey / Red	30/60 Shore	+50 - +113 °F

Identification codes

Drawing	Alphanumeric code	Suction cups with fitting	Order code
A	VG.IS20P.30/60.M5M	VG.IS20 suction cup, polyurethane, 30/60 Shore, M5 male	2322125



Click for Pricing & Add to Cart

A

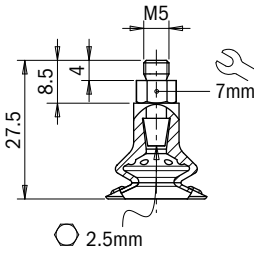

Introduction

Identification codes

Drawing	Alphanumeric code	Suction cups	Order code
A	VG.IS20P.30/60	VG.IS20 suction cup, polyurethane, 30/60 Shore	2322126

A

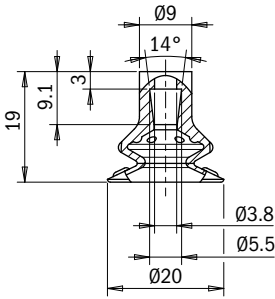

Vacuum theory

Suction cups

Identification codes

Drawing	Alphanumeric code	Fittings	Order code
A	FT.M5M	M5 male fitting	1600005

A

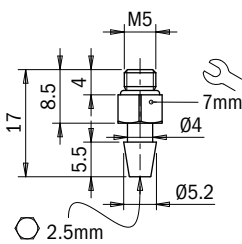

Vacuum pumps

Customised solutions

Suspensions

System accessories

Suction cups / Polyurethane

VG.IS25P bellows suction cups in polyurethane

- Ideal to handle uneven and rough surfaces
- High flexibility: the wide yet thin lip allows for adaptation to uneven surfaces
- Polyurethane material with double hardness, 30/60 Shore
- Good resistance to wear



Application example

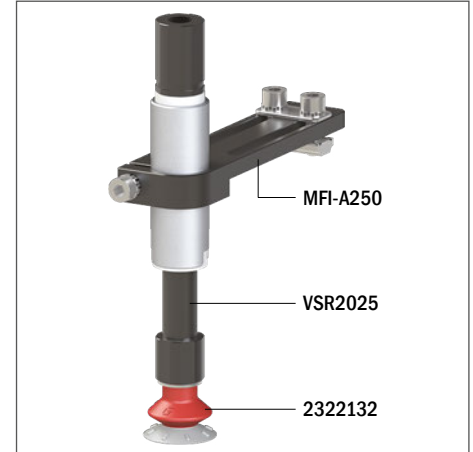

Technical data

Material	Lifting force [N] perpendicular to the surface, at various vacuum levels			Lifting force [N] parallel to the surface, at various vacuum levels			Volume [cm ³]	Min curve radius [mm]	Max vertical movement [mm]	Suction cup weight [g]
	-20 kPa	-60 kPa	-90 kPa	-20 kPa	-60 kPa	-90 kPa				
PU30/60	5.7	12.5	13.4	4.1	7.2	14.1	1.63	9	5.5	1.8

Technical features

Material	Color	Hardness	Temperature range
Polyurethane PU, 30/60 Shore	Grey / Red	30/60 Shore	+50 - +113 °F

Identification codes			
Drawing	Alphanumeric code	Suction cups with fitting	Order code
A	VG.IS25P.30/60.M5F	VG.IS25 suction cup, polyurethane, 30/60 Shore, M5 female	2322129
B	VG.IS25P.30/60.G18M	VG.IS25 suction cup, polyurethane, 30/60 Shore, G1/8" male	2322131
C	VG.IS25P.30/60.G18MF	VG.IS25 suction cup, polyurethane, 30/60 Shore, G1/8" male / M5 female	2322132

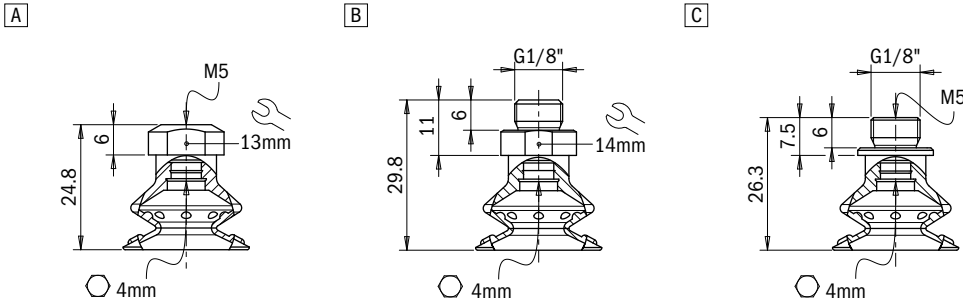

Identification codes			
Drawing	Alphanumeric code	Suction cups	Order code
A	VG.IS25P.30/60	VG.IS25 suction cup, polyurethane, 30/60 Shore	2322130

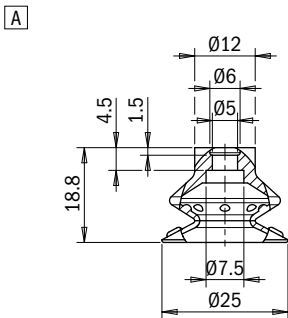

Identification codes			
Drawing	Alphanumeric code	Fittings	Order code
A	FT.M5F	Fitting, M5 female	1700006
B	FT.G18M.17	G1/8" male fitting	1700018
C	FT.G18M.M5F	Fitting, G1/8" male/ M5 female	1700016

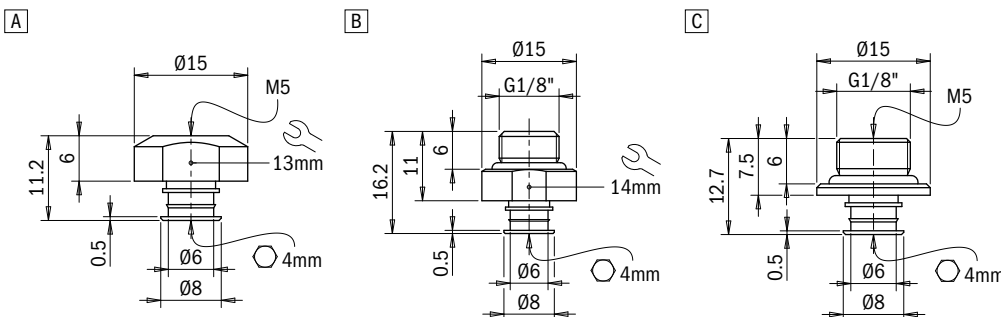

Suction cups / Polyurethane

VG.IS35P bellows suction cups in polyurethane

- Ideal to handle uneven and rough surfaces
- High flexibility: the wide yet thin lip allows for adaptation to uneven surfaces
- Polyurethane material with double hardness, 30/60 Shore
- Good resistance to wear

Application example

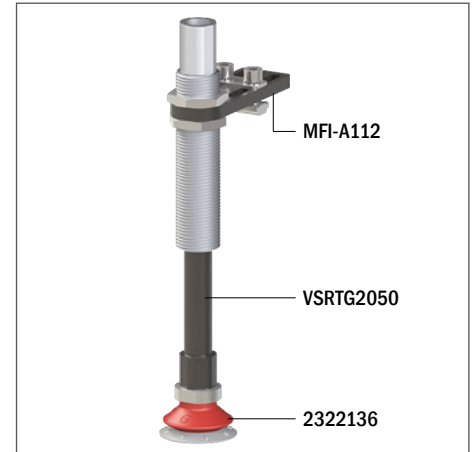

Technical data

Material	Lifting force [N] perpendicular to the surface, at various vacuum levels			Lifting force [N] parallel to the surface, at various vacuum levels			Volume [cm ³]	Min curve radius [mm]	Max vertical movement [mm]	Suction cup weight [g]
	-20 kPa	-60 kPa	-90 kPa	-20 kPa	-60 kPa	-90 kPa				
PU30/60	12.9	33.4	42.3	13	30	34	4.2	16	9.5	4.1

Technical features

Material	Color	Hardness	Temperature range
Polyurethane PU, 30/60 Shore	Grey / Red	30/60 Shore	+50 - +113 °F

Identification codes

Drawing	Alphanumeric code	Suction cups with fitting	Order code
A	VG.IS35P.30/60.G18F	VG.IS35 suction cup, polyurethane, 30/60 Shore, G1/8" female	2322133
B	VG.IS35P.30/60.G18M	VG.IS35 suction cup, polyurethane, 30/60 Shore, G1/8" male	2322135
C	VG.IS35P.30/60.G14M	VG.IS35 suction cup, polyurethane, 30/60 Shore, G1/4" male	2322136
D	VG.IS35P.30/60.G38M	VG.IS35 suction cup, polyurethane, 30/60 Shore, G3/8" male	2322137

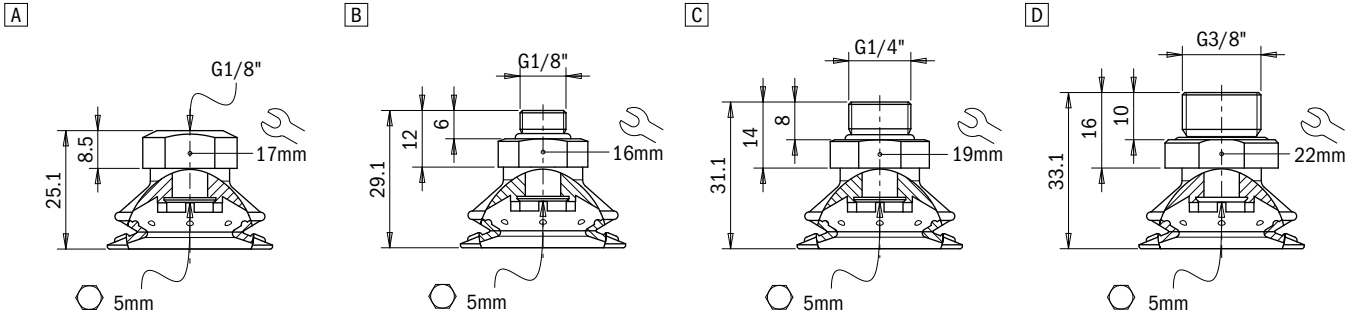

Identification codes

Drawing	Alphanumeric code	Suction cups	Order code
A	VG.IS35P.30/60	VG.IS35 suction cup, polyurethane, 30/60 Shore	2322134

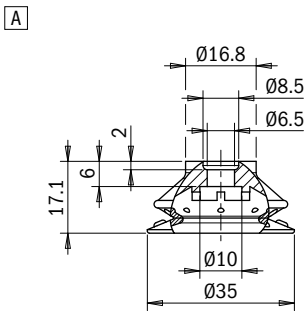

Identification codes

Drawing	Alphanumeric code	Fittings	Order code
A	FT.G18F.18	G1/8" female fitting	1800019
B	FT.G18M.18	G1/8" male fitting	1800018
C	FT.G14M.18	G1/4" male fitting	1800014
D	FT.G38M.18	G3/8" male fitting	1800038

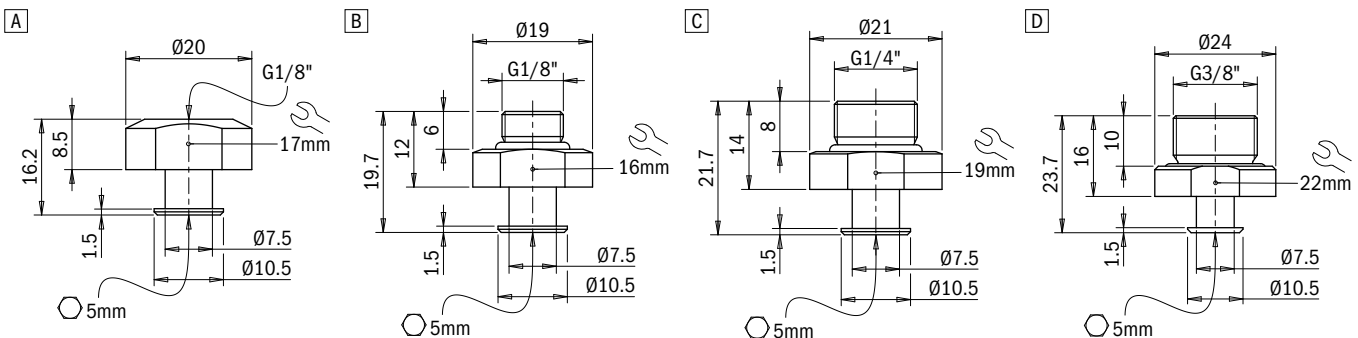

Suction cups / Polyurethane

VG.IS45P bellows suction cups in polyurethane

- Ideal to handle uneven and rough surfaces
- High flexibility: the wide yet thin lip allows for adaptation to uneven surfaces
- Polyurethane material with double hardness, 30/60 Shore
- Good resistance to wear

Application example

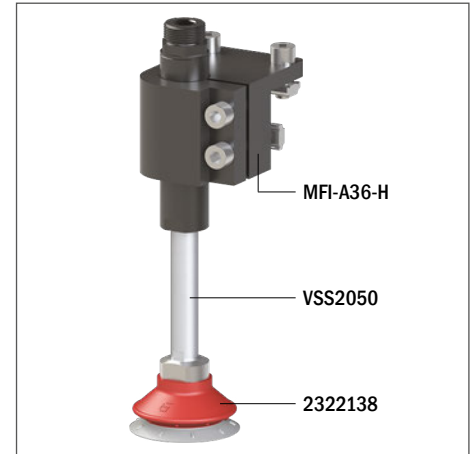

Technical data

Material	Lifting force [N] perpendicular to the surface, at various vacuum levels			Lifting force [N] parallel to the surface, at various vacuum levels			Volume [cm ³]	Min curve radius [mm]	Max vertical movement [mm]	Suction cup weight [g]
	-20 kPa	-60 kPa	-90 kPa	-20 kPa	-60 kPa	-90 kPa				
PU30/60	20.5	44.3	63	15	36	42	14	19	12	8.8

Technical features

Material	Color	Hardness	Temperature range
Polyurethane PU, 30/60 Shore	Grey / Red	30/60 Shore	+50 - +113 °F

Identification codes

Drawing	Alphanumeric code	Suction cups with fitting	Order code
A	VG.IS45P.30/60.G18F	VG.IS45 suction cup, polyurethane, 30/60 Shore, G1/8" female	2322138
B	VG.IS45P.30/60.G18M	VG.IS45 suction cup, polyurethane, 30/60 Shore, G1/8" male	2322140
C	VG.IS45P.30/60.G14M	VG.IS45 suction cup, polyurethane, 30/60 Shore, G1/4" male	2322141
D	VG.IS45P.30/60.G38M	VG.IS45 suction cup, polyurethane, 30/60 Shore, G3/8" male	2322142

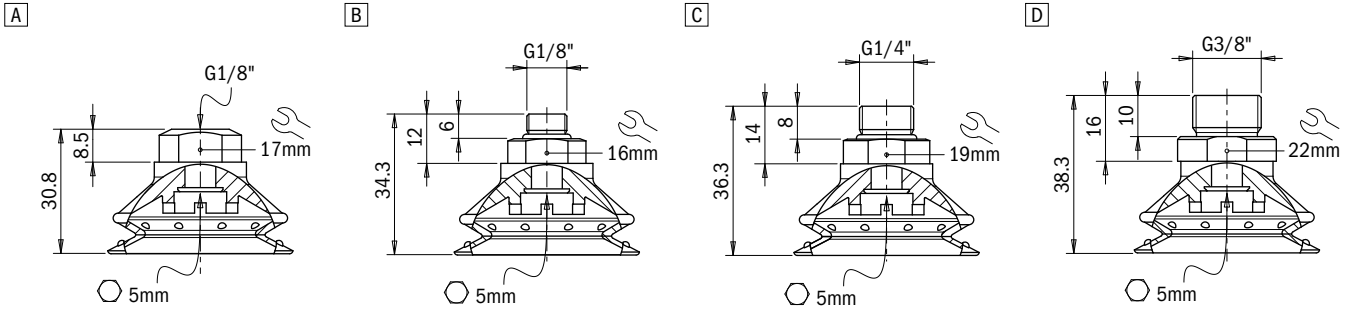

Identification codes

Drawing	Alphanumeric code	Suction cups	Order code
A	VG.IS45P.30/60	VG.IS45 suction cup, polyurethane, 30/60 Shore	2322139

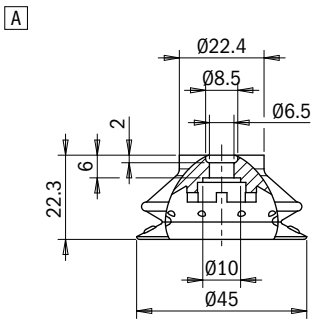

Click for Pricing & Add to Cart



Identification codes

Drawing	Alphanumeric code	Fittings	Order code
A	FT.G18F.18	G1/8" female fitting	1800019
B	FT.G18M.18	G1/8" male fitting	1800018
C	FT.G14M.18	G1/4" male fitting	1800014
D	FT.G38M.18	G3/8" male fitting	1800038

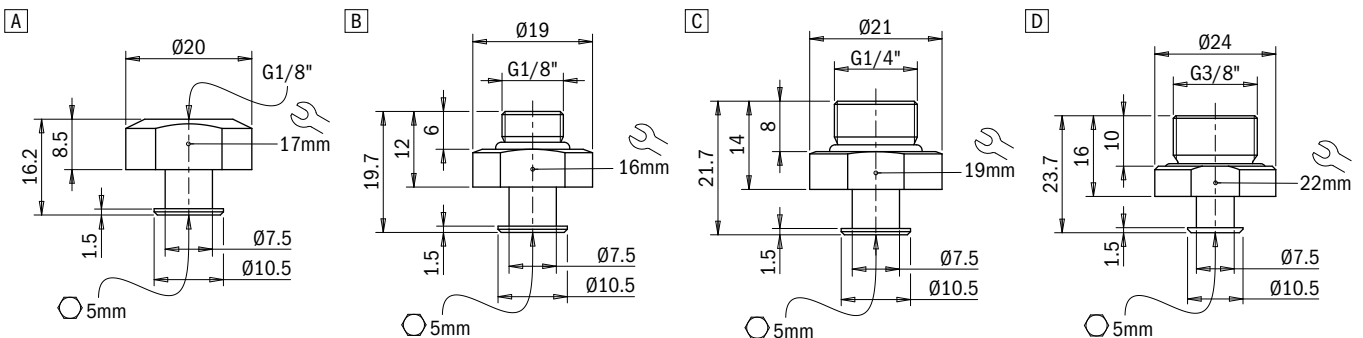

Suction cups / Polyurethane

VG.IS55P bellows suction cups in polyurethane

- Ideal to handle uneven and rough surfaces
- High flexibility: the wide yet thin lip allows for adaptation to uneven surfaces
- Polyurethane material with double hardness, 30/60 Shore
- Good resistance to wear

NEW



Application example

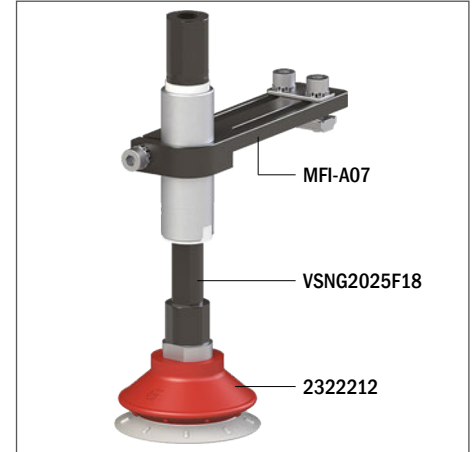

Technical data

Material	Lifting force [N] perpendicular to the surface, at various vacuum levels			Lifting force [N] parallel to the surface, at various vacuum levels			Volume [cm ³]	Min curve radius [mm]	Max vertical movement [mm]	Suction cup weight [g]
	-20 kPa	-60 kPa	-90 kPa	-20 kPa	-60 kPa	-90 kPa				
PU30/60	33.8	78.4	99.7	28.3	70.2	78.7	13	24	11.3	16.2

Technical features

Material	Color	Hardness	Temperature range
Polyurethane PU, 30/60 Shore	Grey / Red	30/60 Shore	+50 - +113 °F

Identification codes

Drawing	Alphanumeric code	Suction cups with fitting	Order code
A	VG.IS55P.30/60.G18M	VG.IS55 suction cup, polyurethane, 30/60 Shore, G1/8" female	2322212
B	VG.IS55P.30/60.G18F	VG.IS55 suction cup, polyurethane, 30/60 Shore, G1/8" male	2322213
C	VG.IS55P.30/60.G14M	VG.IS55 suction cup, polyurethane, 30/60 Shore, G1/4" male	2322214
D	VG.IS55P.30/60.G38M	VG.IS55 suction cup, polyurethane, 30/60 Shore, G3/8" male	2322215

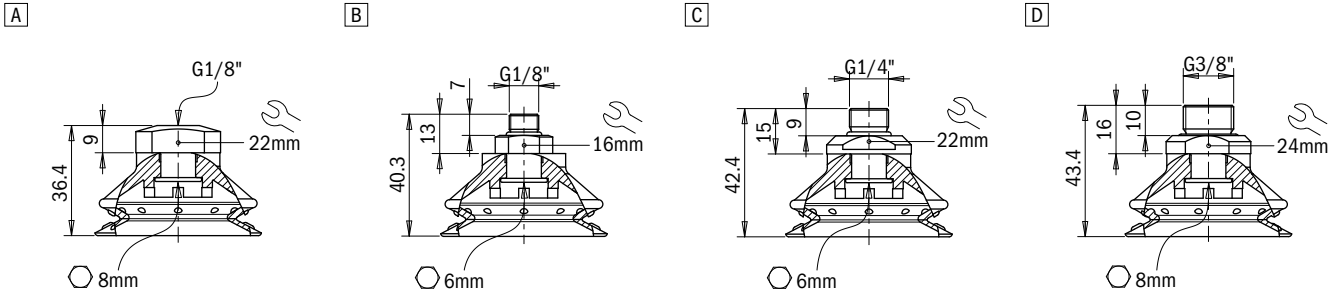

Identification codes

Drawing	Alphanumeric code	Suction cups	Order code
A	VG.IS55P.30/60	VG.IS55 suction cup, polyurethane, 30/60 Shore	2322211

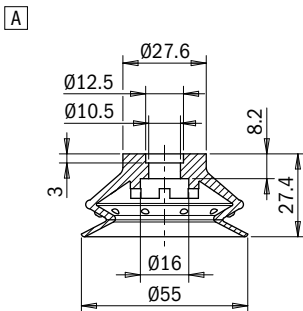

Identification codes

Drawing	Alphanumeric code	Fittings	Order code
A	FT.G18F.19	G1/8" female fitting	1900019
B	FT.G18M.19	G1/8" male fitting	1900018
C	FT.G14M.19	G1/4" male fitting	1900014
D	FT.G38M.198	G3/8" male fitting	1900038

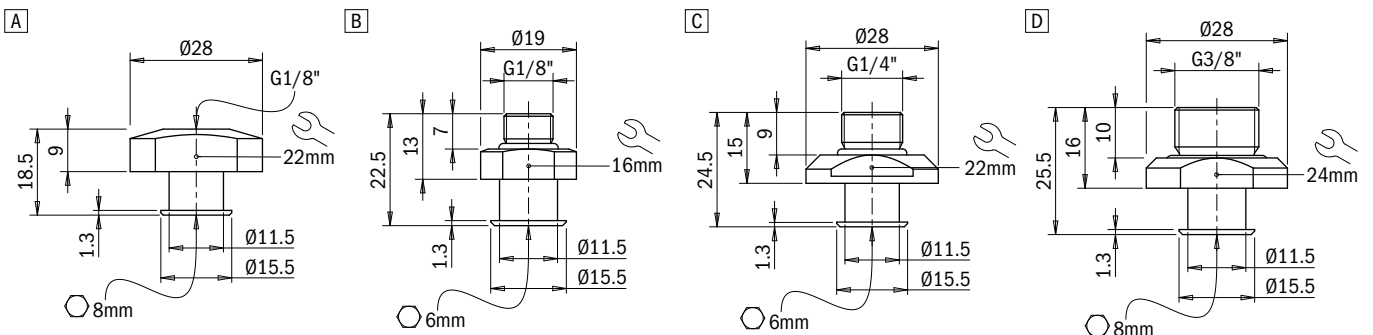

Suction cups / Polyurethane

VG.IS70P bellows suction cups in polyurethane

- Ideal to handle uneven and rough surfaces
- High flexibility: the wide yet thin lip allows for adaptation to uneven surfaces
- Polyurethane material with double hardness, 30/60 Shore
- Good resistance to wear

NEW



Application example

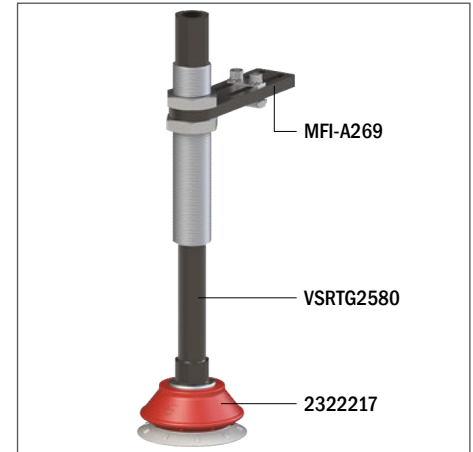

Technical data

Material	Lifting force [N] perpendicular to the surface, at various vacuum levels			Lifting force [N] parallel to the surface, at various vacuum levels			Volume [cm ³]	Min curve radius [mm]	Max vertical movement [mm]	Suction cup weight [g]
	-20 kPa	-60 kPa	-90 kPa	-20 kPa	-60 kPa	-90 kPa				
PU30/60	60.4	113.5	170.3	42.3	75.2	123.1	41.5	51	16.3	40

Technical features

Material	Color	Hardness	Temperature range
Polyurethane PU, 30/60 Shore	Grey / Red	30/60 Shore	+50 - +113 °F

Identification codes			
Drawing	Alphanumeric code	Suction cups with fitting	Order code
A	VG.IS70P.30/60.G38M	VG.IS70 suction cup, polyurethane, 30/60 Shore, G3/8" male	2322217

A

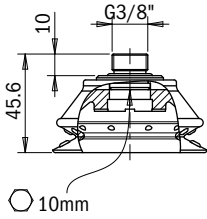

Identification codes			
Drawing	Alphanumeric code	Suction cups	Order code
A	VG.IS70P.30/60	VG.IS70 suction cup, polyurethane, 30/60 Shore	2322216

A

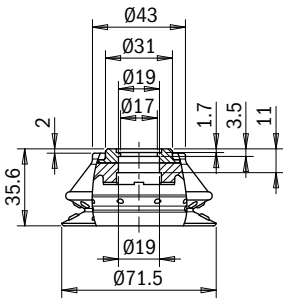

Identification codes			
Drawing	Alphanumeric code	Fittings	Order code
A	FT.G38M.199	G3/8" male fitting	1900039

A

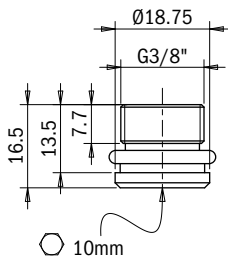

Suction cups / Polyurethane

VG.BR20X45 rectangular bellows suction cups in polyurethane

- Suitable for handling snack foods and food bars in flow packs
- Version with 1.5 bellows
- Ideal for picking up an object and placing it on its side
- Thin lip capable of adapting perfectly to the plastic film

Application example

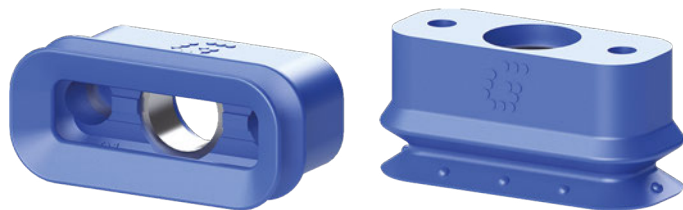
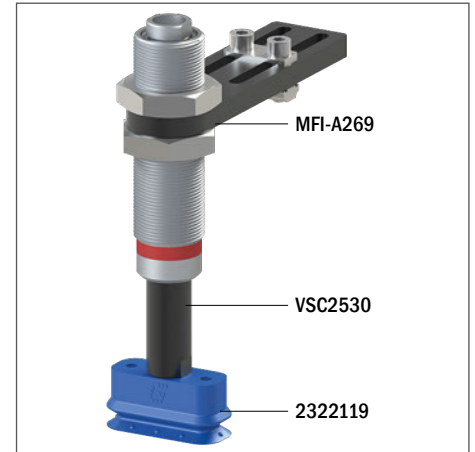

Technical data

Material	Lifting force [N] perpendicular to the surface, at various vacuum levels			Lifting force [N] parallel to the surface, at various vacuum levels			Volume [cm ³]	Min curve radius [mm]	Max vertical movement [mm]	Suction cup weight [g]
	-20 kPa	-60 kPa	-90 kPa	-20 kPa	-60 kPa	-90 kPa				
PU50	15.2	26.4	39.3	21.2	33.4	54	6.1	15	6	7.5

Technical features

Material	Color	Hardness	Temperature range
Polyurethane PU50 Shore	Blue	50 Shore	+50 - +113 °F

Identification codes

Drawing	Alphanumeric code	Suction cups with fitting	Order code
A	VG.BR20X45P.50.G14F	VG.BR20X45 suction cup, polyurethane, 50 Shore, G1/4" Female	2322119

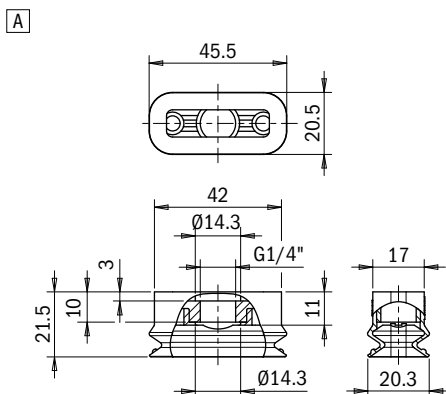

VG.BR30X55 rectangular bellows suction cups in polyurethane

- Suitable for handling snack foods and food bars in flow packs
- Version with 1.5 bellows
- Capable of handling objects with small level differences
- Suitable for applications where grips are parallel or perpendicular to the surface
- Lip capable of adapting perfectly to the plastic film
- Ideal for picking up an object and placing it on its side
- The embossed tread pattern prevents damage to the handled product and implosion of the lip

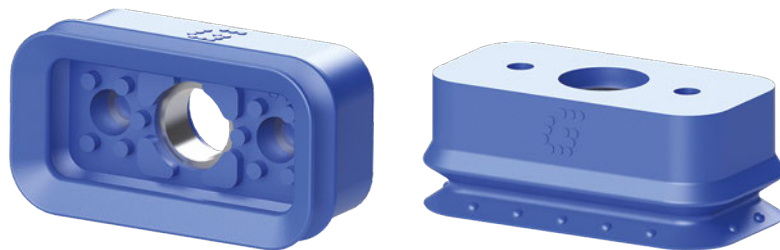

Application example

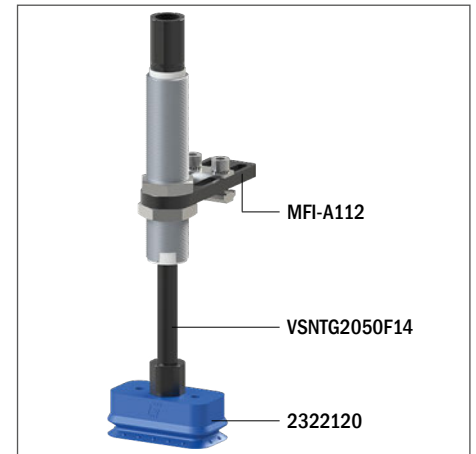

Technical data

Material	Lifting force [N] perpendicular to the surface, at various vacuum levels			Lifting force [N] parallel to the surface, at various vacuum levels			Volume [cm ³]	Min curve radius [mm]	Max vertical movement [mm]	Suction cup weight [g]
	-20 kPa	-60 kPa	-90 kPa	-20 kPa	-60 kPa	-90 kPa				
PU50	23.4	65.3	88.4	24.2	65.4	89.2	16	28	7	16.2

Technical features

Material	Color	Hardness	Temperature range
Polyurethane PU50 Shore	Blue	50 Shore	+50 - +113 °F

Identification codes

Drawing	Alphanumeric code	Suction cups with fitting	Order code
A	VG.BR30X55P.50.G14F	VG.BR30X55 suction cup, polyurethane, 50 Shore, G1/4" Female	2322120

A

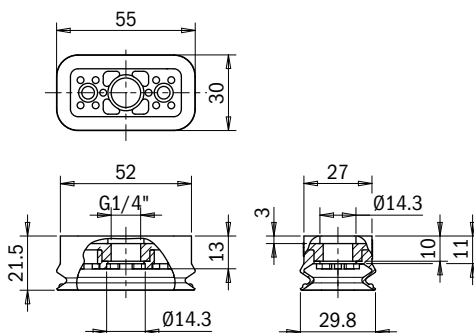

Suction cups / Polyurethane

VG.LBR20X45 rectangular bellows suction cups in polyurethane

- Suitable for handling snack foods and food bars in flow packs
- Version with 2.5 bellows
- Ideal for picking up an object and placing it on its side
- Thin lip capable of adapting perfectly to the plastic film
- Suitable for major level compensations, snack foods with uneven surface

Application example

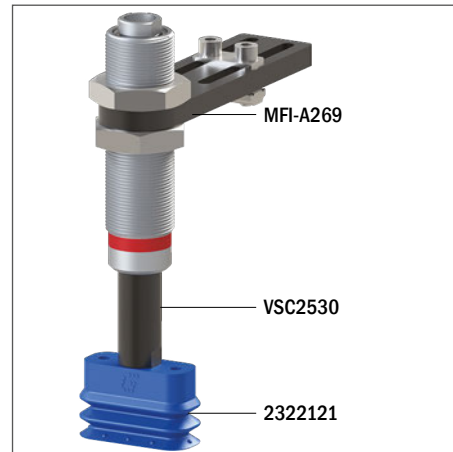

Technical data

Material	Lifting force [N] perpendicular to the surface, at various vacuum levels			Lifting force [N] parallel to the surface, at various vacuum levels			Volume [cm ³]	Min curve radius [mm]	Max vertical movement [mm]	Suction cup weight [g]
	-20 kPa	-60 kPa	-90 kPa	-20 kPa	-60 kPa	-90 kPa				
PU50	14.8	27.5	37.4	21.2	33.4	57.6	8.9	15	12	9.3

Technical features

Material	Color	Hardness	Temperature range
Polyurethane PU50 Shore	Blue	50 Shore	+50 - +113 °F

Identification codes

Drawing	Alphanumeric code	Suction cups with fitting	Order code
A	VG.LBR20X45P.50.G14F	VG.LBR20X45 suction cup, polyurethane, 50 Shore, G1/4" female	2322121

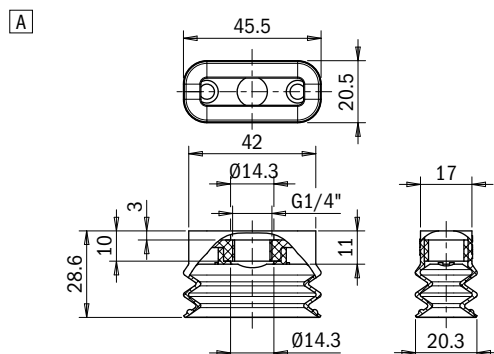

Identification codes

Alphanumeric code	Insert	Order code
AC.IR20X45	Perforated reinforcement insert, 20x45 mm	2322122

Suction cups / Polyurethane

VG.LBR30X55 rectangular bellows suction cups in polyurethane

- Suitable for handling snack foods and food bars in flow packs
- Version with 2.5 bellows
- Capable of handling objects with small level differences
- Suitable for applications where grips are parallel or perpendicular to the surface
- Lip capable of adapting perfectly to the plastic film
- Ideal for picking up an object and placing it on its side
- Suitable for major level compensations, snack foods with uneven surface
- The embossed tread pattern prevents damage to the handled product and implosion of the lip



Application example

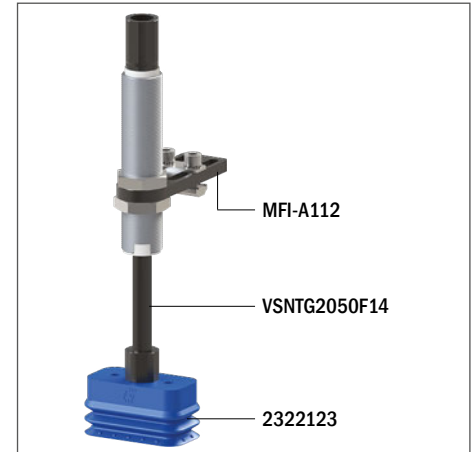

Technical data

Material	Lifting force [N] perpendicular to the surface, at various vacuum levels			Lifting force [N] parallel to the surface, at various vacuum levels			Volume [cm³]	Min curve radius [mm]	Max vertical movement [mm]	Suction cup weight [g]
	-20 kPa	-60 kPa	-90 kPa	-20 kPa	-60 kPa	-90 kPa				
PU50	24.1	72.7	95.3	20.2	49.5	60.2	18.1	28	14	18.9

Technical features

Material	Color	Hardness	Temperature range
Polyurethane PU50 Shore	Blue	50 Shore	+50 - +113 °F

Identification codes

Drawing	Alphanumeric code	Suction cups with fitting	Order code
A	VG.LBR30X55P.50.G14F	VG.LBR30X55 suction cup, polyurethane, 50 Shore, G1/4" female	2322123

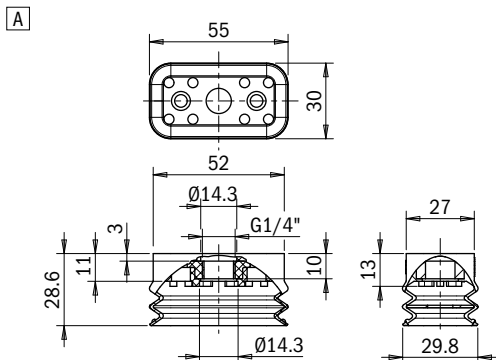

Click for Pricing & Add to Cart



Identification codes

Alphanumeric code	Insert	Order code
AC.IR30X55	Perforated reinforcement insert, 30x55 mm	2322124

Suction cups / Polyurethane

VG.MF20P flat suction cup with non-slip tread pattern in polyurethane

- Ideal for handling oiled sheet metal in stamping processes
- Special tread pattern that increases friction on lubricated surfaces
- Excellent stability

Introduction

Vacuum theory

Suction cups



Application example

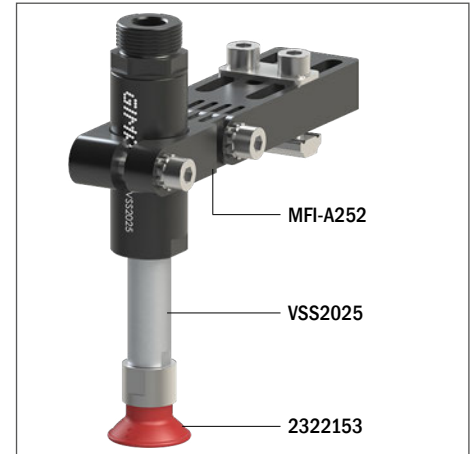

Vacuum pumps

Customised solutions

Suspensions

System accessories

Technical data

Material	Lifting force [N] perpendicular to the surface, at various vacuum levels			Lifting force [N] parallel to the surface, at various vacuum levels			Volume [cm ³]	Min curve radius [mm]	Max vertical movement [mm]	Suction cup weight [g]
	-20 kPa	-60 kPa	-90 kPa	-20 kPa	-60 kPa	-90 kPa				
PU40	5.1	12.4	16.5	5.1	9	12	1	25	1.9	1

Technical features

Material	Color	Hardness	Temperature range
Polyurethane PU40 Shore	Red	40 Shore	+50 - +113 °F

Identification codes

Drawing	Alphanumeric code	Suction cups with fitting	Order code
A	VG.MF20P.40.G18M	VG.MF20 suction cup, polyurethane, 40 Shore, G1/8" male	2322151
B	VG.MF20P.40.G18F	VG.MF20 suction cup, polyurethane, 40 Shore, G1/8" female	2322153

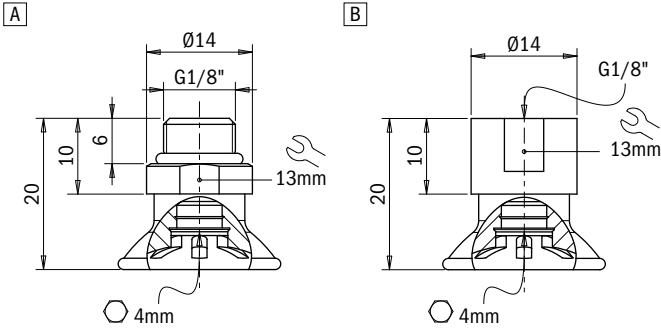

Identification codes

Drawing	Alphanumeric code	Suction cups	Order code
A	VG.MF20P.40	VG.MF20 suction cup, polyurethane, 40 Shore	2322152

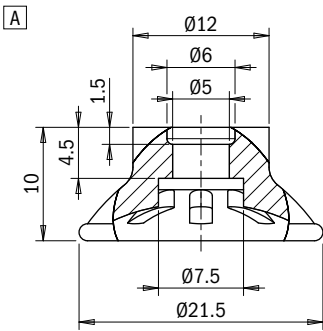

Click for Pricing & Add to Cart

Identification codes

Drawing	Alphanumeric code	Fittings	Order code
A	FT.G18M.20	G1/8" male fitting	2000018
B	FT.G18F.20	G1/8" female fitting	2000019

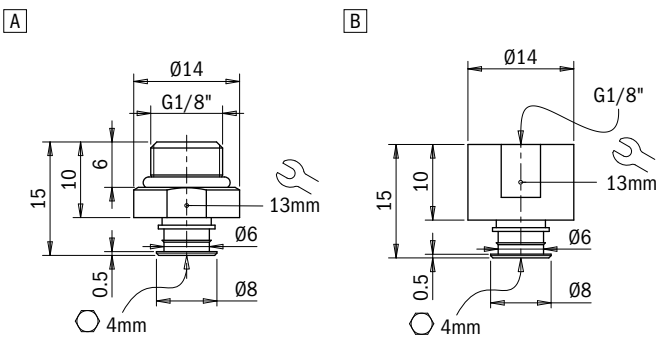

Suction cups / Polyurethane

VG.MF30P flat suction cup with non-slip tread pattern in polyurethane

- Ideal for handling oiled sheet metal in stamping processes
- Special tread pattern that increases friction on lubricated surfaces
- Excellent stability

Introduction

Vacuum theory

Suction cups



Application example

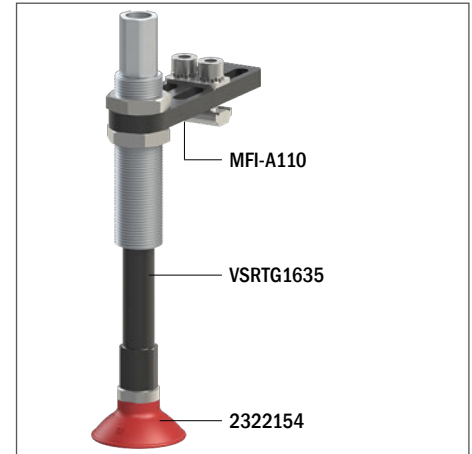

Vacuum pumps

Customised solutions

Suspensions

System accessories

Technical data

Material	Lifting force [N] perpendicular to the surface, at various vacuum levels			Lifting force [N] parallel to the surface, at various vacuum levels			Volume [cm ³]	Min curve radius [mm]	Max vertical movement [mm]	Suction cup weight [g]
	-20 kPa	-60 kPa	-90 kPa	-20 kPa	-60 kPa	-90 kPa				
PU40	10	33	48	26	40	49	4.8	30	5.3	2.3

Technical features

Material	Color	Hardness	Temperature range
Polyurethane PU40 Shore	Red	40 Shore	+50 - +113 °F

Identification codes

Drawing	Alphanumeric code	Suction cups with fitting	Order code
A	VG.MF30P.40.G18M	VG.MF30 suction cup, polyurethane, 40 Shore, G1/8" male	2322154
B	VG.MF30P.40.G18F	VG.MF30 suction cup, polyurethane, 40 Shore, G1/8" female	2322156

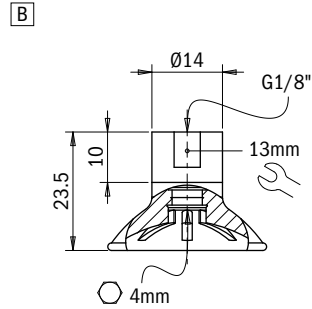
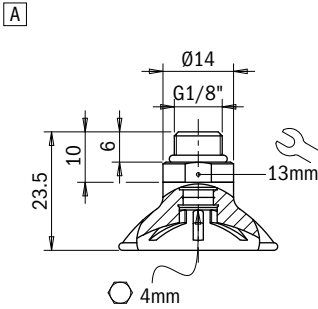

Identification codes

Drawing	Alphanumeric code	Suction cups	Order code
A	VG.MF30P.40	VG.MF30 suction cup, polyurethane, 40 Shore	2322155

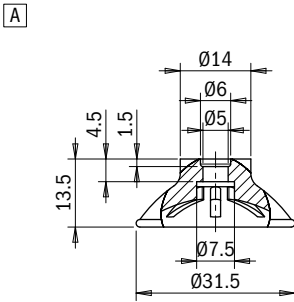

Identification codes

Drawing	Alphanumeric code	Fittings	Order code
A	FT.G18M.20	G1/8" male fitting	2000018
B	FT.G18F.20	G1/8" female fitting	2000019

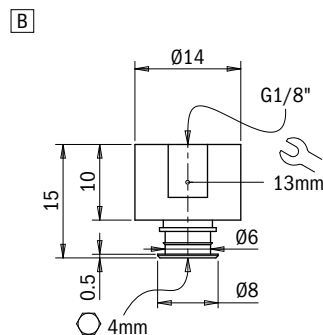
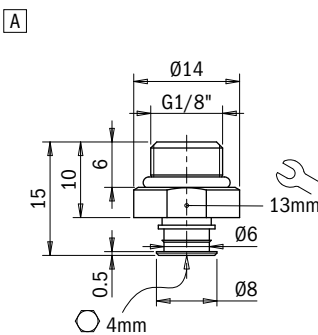

Suction cups / Polyurethane

VG.MF45P flat suction cup with non-slip tread pattern in polyurethane

- Ideal for handling oiled sheet metal in stamping processes
- Special tread pattern that increases friction on lubricated surfaces
- Excellent stability

NEW

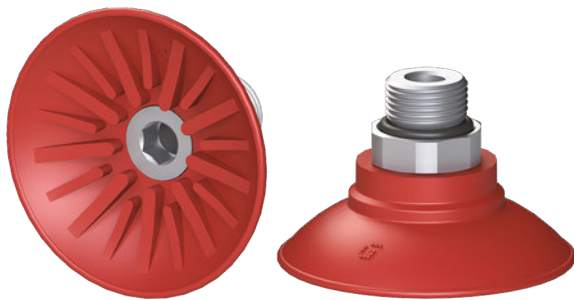

Application example

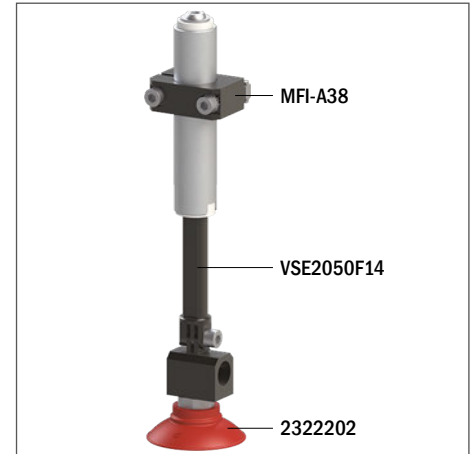

Technical data

Material	Lifting force [N] perpendicular to the surface, at various vacuum levels			Lifting force [N] parallel to the surface, at various vacuum levels			Volume [cm ³]	Min curve radius [mm]	Max vertical movement [mm]	Suction cup weight [g]
	-20 kPa	-60 kPa	-90 kPa	-20 kPa	-60 kPa	-90 kPa				
PU40	24.2	70.5	92.6	40.2	80.3	93	9.8	50	5.3	25

Technical features

Material	Color	Hardness	Temperature range
Polyurethane PU40 Shore	Red	40 Shore	+50 - +113 °F

Identification codes

Drawing	Alphanumeric code	Suction cups with fitting	Order code
A	VG.MF45P.40.G14M	VG.MF45 suction cup, polyurethane, 40 Shore, G1/4" male	2322202
B	VG.MF45P.40.G14F	VG.MF45 suction cup, polyurethane, 40 Shore, G1/4" female	2322203

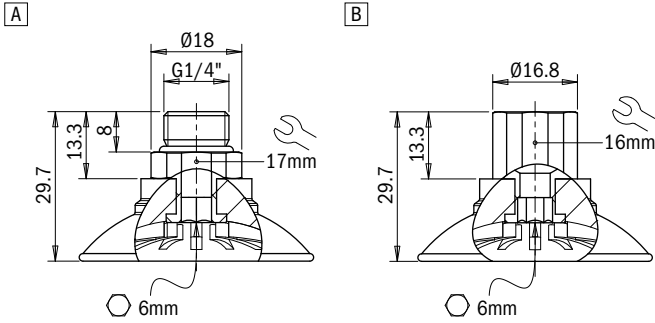

Identification codes

Drawing	Alphanumeric code	Suction cups	Order code
A	VG.MF45P.40	VG.MF45 suction cup, polyurethane, 40 Shore	2322201

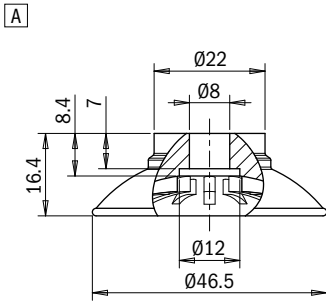

Identification codes

Drawing	Alphanumeric code	Fittings	Order code
A	FT.G14M.20	G1/4" male fitting	2321432
B	FT.G14F.20	G1/4" female fitting	2321430

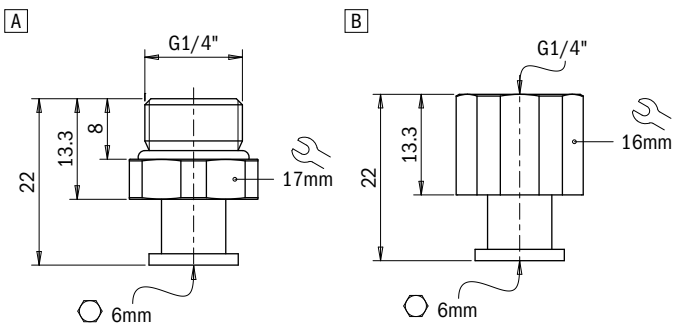

Suction cups / Polyurethane

VG.MF60P flat suction cup with non-slip tread pattern in polyurethane

- Ideal for handling lubricated sheet metal in stamping processes
- Special tread pattern that increases friction on lubricated surfaces
- Vulcanised fittings for greater stability during fastening, the suction cups can withstand high shear forces

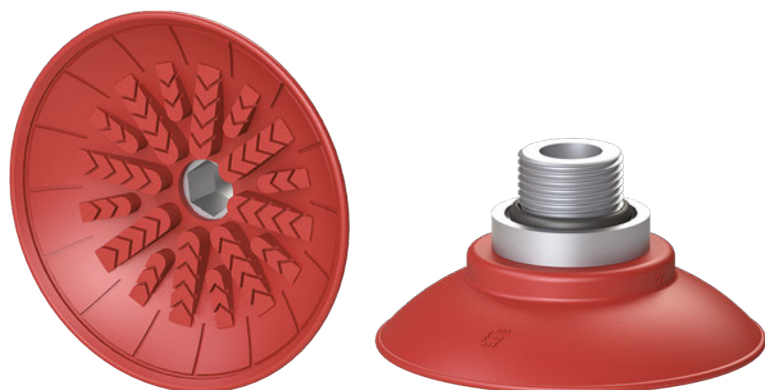

Application example



Technical data

Material	Lifting force [N] perpendicular to the surface, at various vacuum levels			Lifting force [N] parallel to the surface, at various vacuum levels			Volume [cm ³]	Min curve radius [mm]	Max vertical movement [mm]	Suction cup weight [g]
	-20 kPa	-60 kPa	-90 kPa	-20 kPa	-60 kPa	-90 kPa				
PU40	49	95	115	50	85	118	25	58	5.4	29

Technical features

Material	Color	Hardness	Temperature range
Polyurethane PU40 Shore	Red	40 Shore	+50 - +113 °F

Identification codes

Drawing	Alphanumeric code	Suction cups with fitting	Order code
A	VG.MF60P.40.G38M	VG.MF60 suction cup, polyurethane, 40 Shore, G3/8" male	2322157
B	VG.MF60P.40.G38F	VG.MF60 suction cup, polyurethane, 40 Shore, G3/8" female	2322158

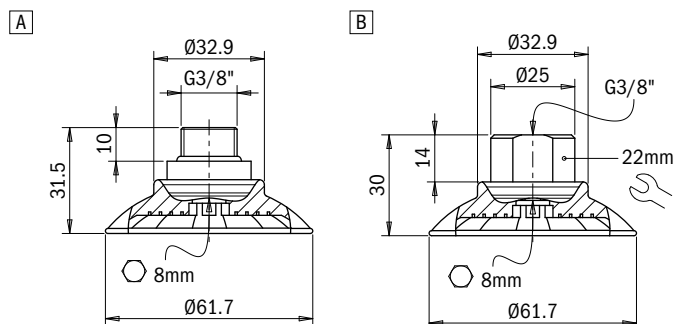

VG.MF80P flat suction cup with non-slip tread pattern in polyurethane

- Ideal for handling lubricated sheet metal in stamping processes
- Special tread pattern that increases friction on lubricated surfaces
- Vulcanised fittings for greater stability during fastening, the suction cups can withstand high shear forces



Application example



Technical data

Material	Lifting force [N] perpendicular to the surface, at various vacuum levels			Lifting force [N] parallel to the surface, at various vacuum levels			Volume [cm ³]	Min curve radius [mm]	Max vertical movement [mm]	Suction cup weight [g]
	-20 kPa	-60 kPa	-90 kPa	-20 kPa	-60 kPa	-90 kPa				
PU40	80	188	238	93	190	240	31	79	7.1	47

Technical features

Material	Color	Hardness	Temperature range
Polyurethane PU40 Shore	Red	40 Shore	+50 - +113 °F

Identification codes

Drawing	Alphanumeric code	Suction cups with fitting	Order code
A	VG.MF80P.40.G38M	VG.MF80 suction cup, polyurethane, 40 Shore, G3/8" male	2322159
B	VG.MF80P.40.G38F	VG.MF80 suction cup, polyurethane, 40 Shore, G3/8" female	2322160

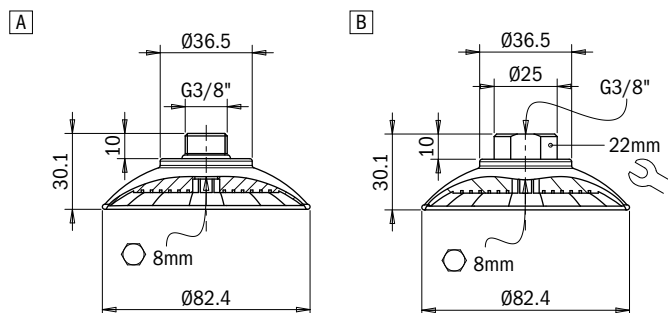

Suction cups / Polyurethane

VG.MF100P flat suction cup with non-slip tread pattern in polyurethane

- Ideal for handling lubricated sheet metal in stamping processes
- Special tread pattern that increases friction on lubricated surfaces
- Vulcanised fittings for greater stability during fastening, the suction cups can withstand high shear forces

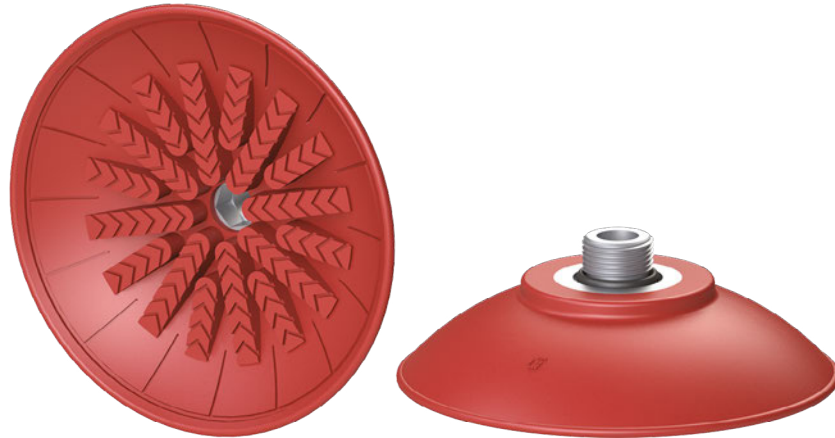

Application example



Technical data

Material	Lifting force [N] perpendicular to the surface, at various vacuum levels			Lifting force [N] parallel to the surface, at various vacuum levels			Volume [cm ³]	Min curve radius [mm]	Max vertical movement [mm]	Suction cup weight [g]
	-20 kPa	-60 kPa	-90 kPa	-20 kPa	-60 kPa	-90 kPa				
PU40	140	300	390	178	320	410	81	110	10.3	60

Technical features

Material	Color	Hardness	Temperature range
Polyurethane PU40 Shore	Red	40 Shore	+50 - +113 °F

Identification codes

Drawing	Alphanumeric code	Suction cups with fitting	Order code
A	VG.MF100P.40.G38M	VG.MF100 suction cup, polyurethane, 40 Shore, G3/8" male	2322161
B	VG.MF100P.40.G38F	VG.MF100 suction cup, polyurethane, 40 Shore, G3/8" female	2322162

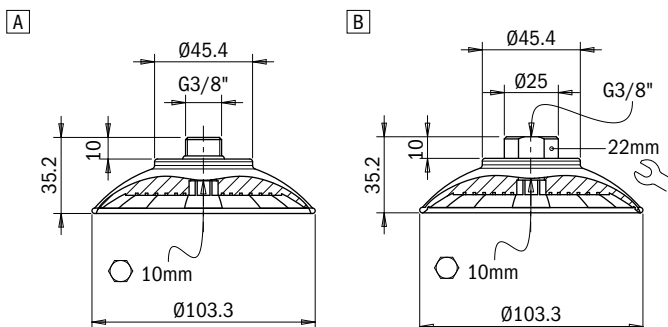

VG.MF120P flat suction cup with non-slip tread pattern in polyurethane

- Ideal for handling lubricated sheet metal in stamping processes
- Special tread pattern that increases friction on lubricated surfaces
- Vulcanised fittings for greater stability during fastening, the suction cups can withstand high shear forces



Application example



Technical data

Material	Lifting force [N] perpendicular to the surface, at various vacuum levels			Lifting force [N] parallel to the surface, at various vacuum levels			Volume [cm ³]	Min curve radius [mm]	Max vertical movement [mm]	Suction cup weight [g]
	-20 kPa	-60 kPa	-90 kPa	-20 kPa	-60 kPa	-90 kPa				
PU40	226	630	850	200	500	790	210	155	12.5	63

Technical features

Material	Color	Hardness	Temperature range
Polyurethane PU40 Shore	Red	40 Shore	+50 - +113 °F

Identification codes

Drawing	Alphanumeric code	Suction cups with fitting	Order code
A	VG.MF120P.40.G38M	VG.MF120 suction cup, polyurethane, 40 Shore, G3/8" male	2322163
B	VG.MF120P.40.G38F	VG.MF120 suction cup, polyurethane, 40 Shore, G3/8" female	2322164

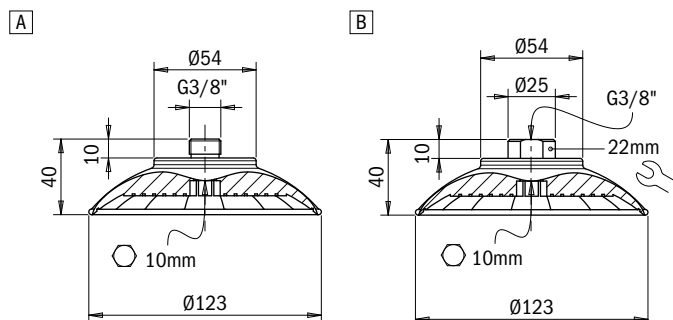

Suction cups / FDA-compliant silicone

VG.BPG30F multi-bellows suction cups in FDA-compliant silicone

- Suitable for handling bags, pouches and flexible packages for solids and liquids
- Version with 1.5 bellows
- Suction cups in FDA-compliant silicone
- Reinforced bellows for higher grip stability
- The lip of the suction cup has been designed to maximise the grip and allow perfect adhesion even on wrinkles without damaging the grip surfaces

NEW



Application example

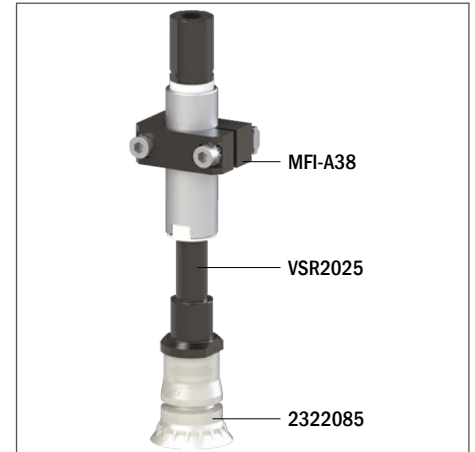

Technical data

Material	Lifting force [N] perpendicular to the surface, at various vacuum levels			Lifting force [N] parallel to the surface, at various vacuum levels			Volume [cm ³]	Min curve radius [mm]	Max vertical movement [mm]	Suction cup weight [g]
	-20 kPa	-50 kPa	-60 kPa	-20 kPa	-50 kPa	-60 kPa				
SIL 40 FDA	9.4	16.8	18.5	6.7	11	11.8	7.3	15	3	7.5

Technical features

Material	Color	Hardness	Temperature range
Silicone, FDA SIL	Transparent	40 Shore	-94 - +392 °F

Identification codes			
Drawing	Alphanumeric code	Suction cups with fitting	Order code
A	VG.BPG30F.40.G18M	VG.BPG30 suction cup, FDA-compliant silicone, 40 Shore, with internal insert, G1/8" male	2322085
B	VG.BPG30F.40.G14M	VG.BPG30 suction cup, FDA-compliant silicone, 40 Shore, with internal insert, G1/4" male	2322087
C	VG.BPG30F.40.G38M	VG.BPG30 suction cup, FDA-compliant silicone, 40 Shore, with internal insert, G3/8" male	2322088

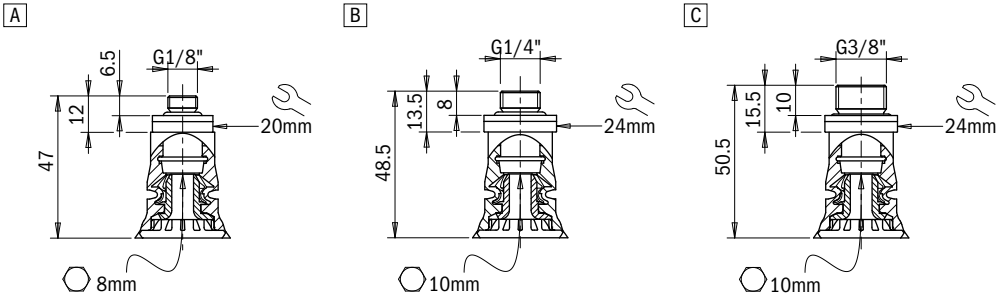

Identification codes			
Drawing	Alphanumeric code	Suction cups	Order code
A	VG.BPG30F.40	VG.BPG30 suction cup, FDA-compliant silicone, 40 Shore, with internal insert	2322086

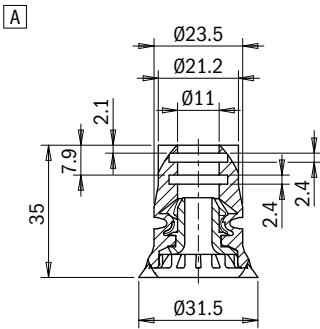

Click for Pricing & Add to Cart



Identification codes			
Drawing	Alphanumeric code	Fittings	Order code
A	FT.G18M.E8	G1/8" male fitting	1900017
B	FT.G14M.E10	G1/4" male fitting	1900013
C	FT.G38M.E10	G3/8" male fitting	1900037

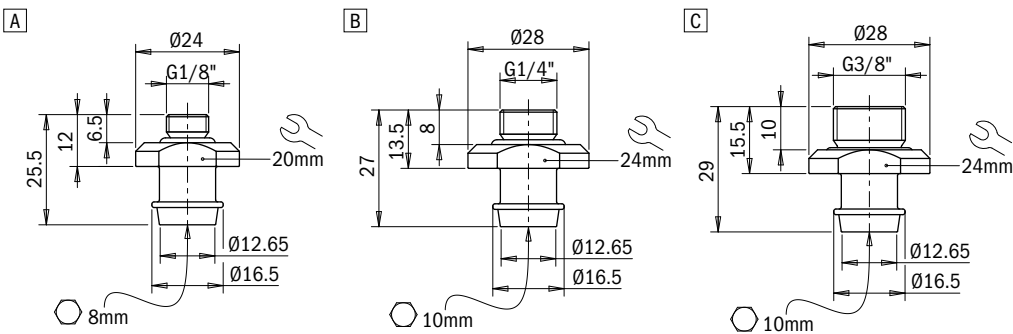

Identification codes		
Alphanumeric code	Insert	Order code
AC.BPG30	Spare insert for flow packs, size 30 mm in PA12 GB material	2302147

Suction cups / FDA-compliant silicone

VG.BPG41F multi-bellows suction cups in FDA-compliant silicone

- Suitable for handling bags, pouches and flexible packages for solids and liquids
- Version with 1.5 bellows
- Suction cups in FDA-compliant silicone
- Reinforced bellows for higher grip stability
- The lip of the suction cup has been designed to maximise the grip and allow perfect adhesion even on wrinkles without damaging the grip surfaces

NEW



Application example



Technical data

Material	Lifting force [N] perpendicular to the surface, at various vacuum levels			Lifting force [N] parallel to the surface, at various vacuum levels			Volume [cm ³]	Min curve radius [mm]	Max vertical movement [mm]	Suction cup weight [g]
	-20 kPa	-50 kPa	-60 kPa	-20 kPa	-50 kPa	-60 kPa				
SIL 40 FDA	14	19.4	23.7	8.3	13	15.9	13.4	20.5	3.5	13.7

Technical features

Material	Color	Hardness	Temperature range
Silicone, FDA SIL	Transparent	40 Shore	-94 - +392 °F

Identification codes			
Drawing	Alphanumeric code	Suction cups with fitting	Order code
A	VG.BPG41F.40.G18M	VG.BPG41 suction cup, FDA-compliant silicone, 40 Shore, with internal insert, G1/8" male	2322089
B	VG.BPG41F.40.G14M	VG.BPG41 suction cup, FDA-compliant silicone, 40 Shore, with internal insert, G1/4" male	2322091
C	VG.BPG41F.40.G38M	VG.BPG41 suction cup, FDA-compliant silicone, 40 Shore, with internal insert, G3/8" male	2322092

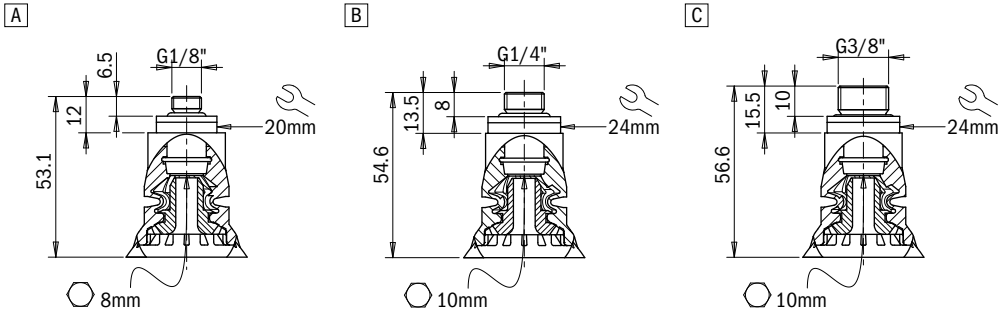

Identification codes			
Drawing	Alphanumeric code	Suction cups	Order code
A	VG.BPG41F.40	VG.BPG41 suction cup, FDA-compliant silicone, 40 Shore, with internal insert	2322090

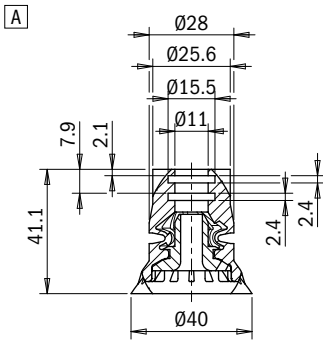

Identification codes			
Drawing	Alphanumeric code	Fittings	Order code
A	FT.G18M.E8	G1/8" male fitting	1900017
B	FT.G14M.E10	G1/4" male fitting	1900013
C	FT.G38M.E10	G3/8" male fitting	1900037

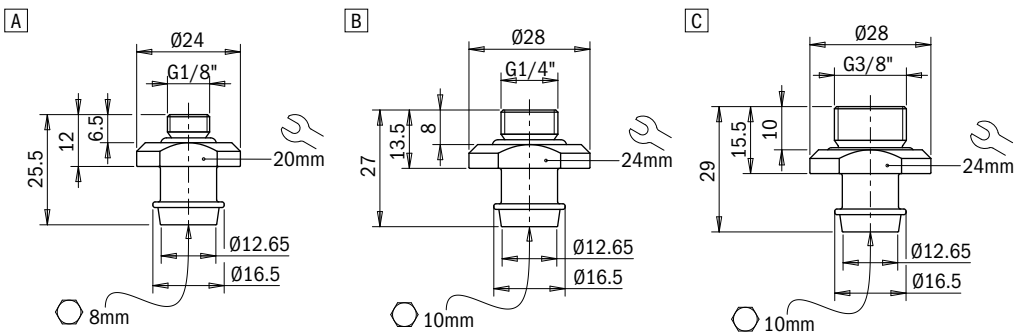

Identification codes		
Alphanumeric code	Insert	Order code
AC.BPG41	Spare insert for flow packs, size 41 mm in PA12 GB material	2302148

Suction cups / FDA-compliant silicone

VG.BPG48F multi-bellows suction cups in FDA-compliant silicone

- Suitable for handling bags, pouches and flexible packages for solids and liquids
- Version with 1.5 bellows
- Suction cups in FDA-compliant silicone
- Reinforced bellows for higher grip stability
- The lip of the suction cup has been designed to maximise the grip and allow perfect adhesion even on wrinkles without damaging the grip surfaces

NEW



Application example

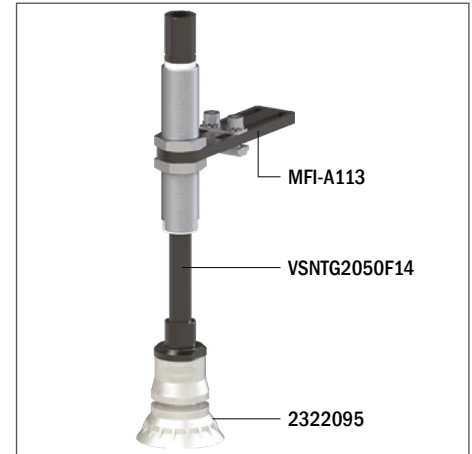

Technical data

Material	Lifting force [N] perpendicular to the surface, at various vacuum levels			Lifting force [N] parallel to the surface, at various vacuum levels			Volume [cm ³]	Min curve radius [mm]	Max vertical movement [mm]	Suction cup weight [g]
	-20 kPa	-50 kPa	-60 kPa	-20 kPa	-50 kPa	-60 kPa				
SIL 40 FDA	19.8	26	32.9	10.9	16.5	22	17.9	24	4	18.4

Technical features

Material	Colour	Hardness	Temperature range
Silicone, FDA SIL	Transparent	40 Shore	-94 - +392 °F

Identification codes			
Drawing	Alphanumeric code	Suction cups with fitting	Order code
A	VG.BPG48F.40.G18M	VG.BPG48 suction cup, FDA-compliant silicone, 40 Shore, with internal insert, G1/8" male	2322093
B	VG.BPG48F.40.G14M	VG.BPG48 suction cup, FDA-compliant silicone, 40 Shore, with internal insert, G1/4" male	2322095
C	VG.BPG48F.40.G38M	VG.BPG48 suction cup, FDA-compliant silicone, 40 Shore, with internal insert, G3/8" male	2322096

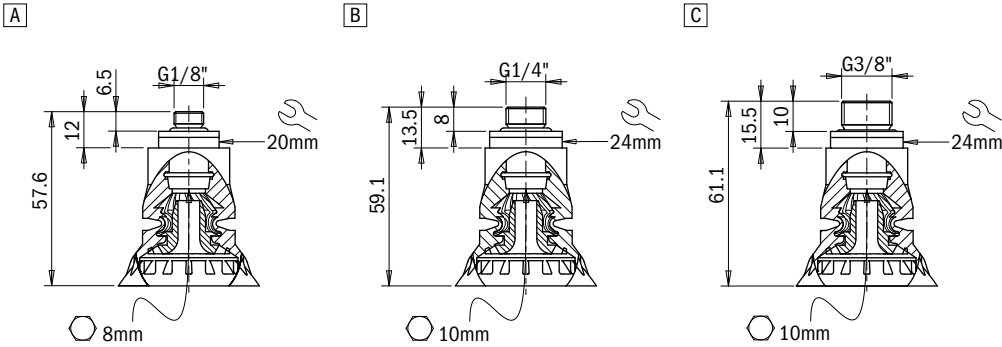

Identification codes			
Drawing	Alphanumeric code	Suction cups	Order code
A	VG.BPG48F.40	VG.BPG48 suction cup, FDA-compliant silicone, 40 Shore, with internal insert	2322094

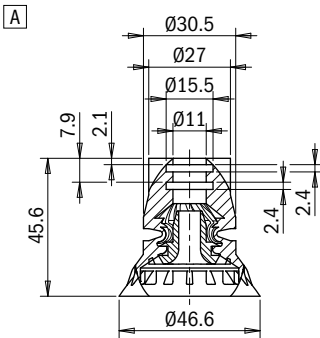

Identification codes			
Drawing	Alphanumeric code	Fittings	Order code
A	FT.G18M.E8	G1/8" male fitting	1900017
B	FT.G14M.E10	G1/4" male fitting	1900013
C	FT.G38M.E10	G3/8" male fitting	1900037

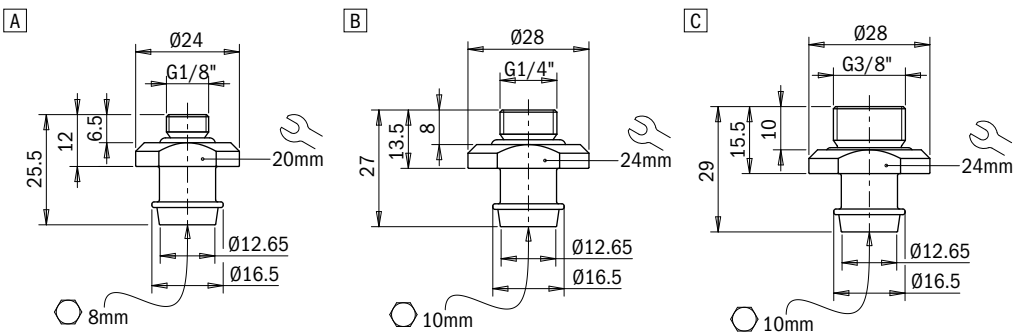

Identification codes		
Alphanumeric code	Insert	Order code
AC.BPG48	Spare insert for flow packs, size 48 mm in PA12 GB material	2302149

Suction cups / FDA-compliant silicone

VG.BPG55F multi-bellows suction cups in FDA-compliant silicone

- Suitable for handling bags, pouches and flexible packages for solids and liquids
- Version with 1.5 bellows
- Suction cups in FDA-compliant silicone
- Reinforced bellows for higher grip stability
- The lip of the suction cup has been designed to maximise the grip and allow perfect adhesion even on wrinkles without damaging the grip surfaces

NEW



Fixing example

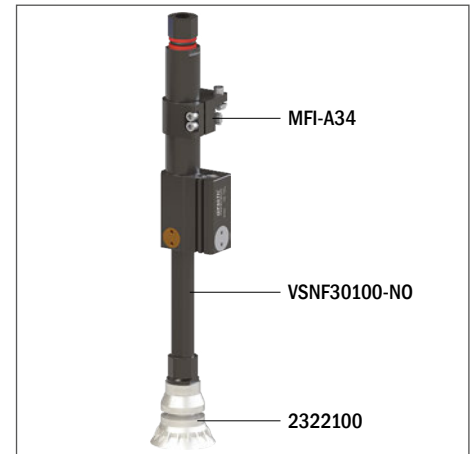

Technical data

Material	Lifting force [N] perpendicular to the surface, at various vacuum levels			Lifting force [N] parallel to the surface, at various vacuum levels			Volume [cm ³]	Min curve radius [mm]	Max vertical movement [mm]	Suction cup weight [g]
	-20 kPa	-50 kPa	-60 kPa	-20 kPa	-50 kPa	-60 kPa				
SIL 40 FDA	22	35.8	48.7	15.2	22.3	31.2	31.8	27.5	5.3	32.5

Technical features

Material	Color	Hardness	Temperature range
Silicone, FDA SIL	Transparent	40 Shore	-94 - +392 °F

Identification codes			
Drawing	Alphanumeric code	Suction cups with fitting	Order code
A	VG.BPG55F.40.G18M	VG.BPG55 suction cup, FDA-compliant silicone, 40 Shore, with internal insert, G1/8" male	2322097
B	VG.BPG55F.40.G14M	VG.BPG55 suction cup, FDA-compliant silicone, 40 Shore, with internal insert, G1/4" male	2322099
C	VG.BPG55F.40.G38M	VG.BPG55 suction cup, FDA-compliant silicone, 40 Shore, with internal insert, G3/8" male	2322100

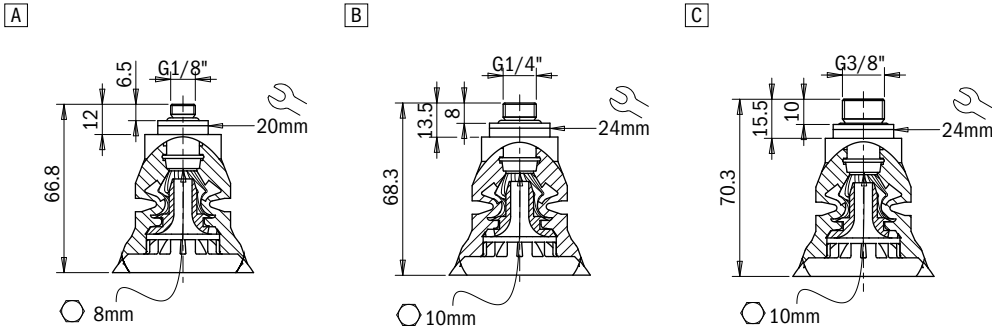

Identification codes			
Drawing	Alphanumeric code	Suction cups	Order code
A	VG.BPG55F.40	VG.BPG55 suction cup, FDA-compliant silicone, 40 Shore, with internal insert	2322098

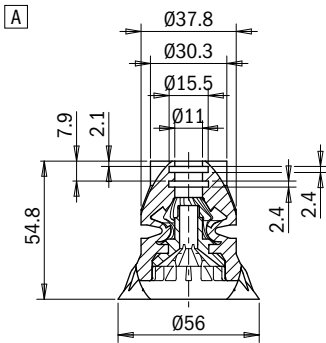

Identification codes			
Drawing	Alphanumeric code	Fittings	Order code
A	FT.G18M.E8	G1/8" male fitting	1900017
B	FT.G14M.E10	G1/4" male fitting	1900013
C	FT.G38M.E10	G3/8" male fitting	1900037

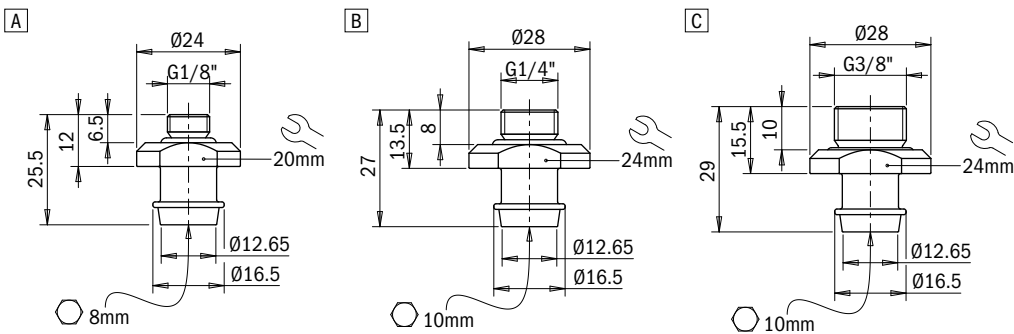

Identification codes		
Alphanumeric code	Insert	Order code
AC.BPG55	Spare insert for flow packs, size 55 mm in PA12 GB material	2302150

Suction cups / FDA-compliant silicone

VG.BPG30FSI multi-bellows suction cups in FDA-compliant silicone

- Suitable for handling bags, pouches and flexible packages for solids and liquids
- Version with 1.5 bellows
- Suction cups in FDA-compliant silicone
- Ideal for handling unpackaged food products such as pralines or biscuits with porous and uneven surfaces
- Reinforced bellows for higher grip stability
- The lip of the suction cup has been designed to maximise the grip and allow perfect adhesion even on wrinkles without damaging the grip surfaces

NEW



Application example

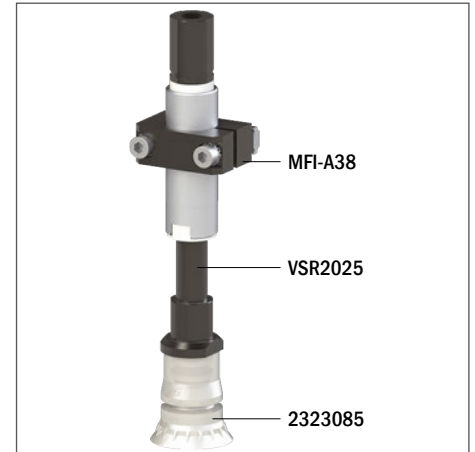

Technical data

Material	Lifting force [N] perpendicular to the surface, at various vacuum levels			Lifting force [N] parallel to the surface, at various vacuum levels			Volume [cm ³]	Min curve radius [mm]	Max vertical movement [mm]	Suction cup weight [g]
	-20 kPa	-50 kPa	-60 kPa	-20 kPa	-50 kPa	-60 kPa				
SIL 40 FDA	9.4	16.8	18.5	6.7	11	11.8	7.3	15	3	7.5

Technical features

Material	Color	Hardness	Temperature range
Silicone, FDA SIL	Transparent	40 Shore	-94 - +392 °F

Identification codes			
Drawing	Alphanumeric code	Suction cups with fitting	Order code
A	VG.BPG30FSI.40.G18M	VG.BPG30 suction cup, FDA-compliant silicone, 40 Shore, G1/8" male	2323085
B	VG.BPG30FSI.40.G14M	VG.BPG30 suction cup, FDA-compliant silicone, 40 Shore, G1/4" male	2323087
C	VG.BPG30FSI.40.G38M	VG.BPG30 suction cup, FDA-compliant silicone, 40 Shore, G3/8" male	2323088

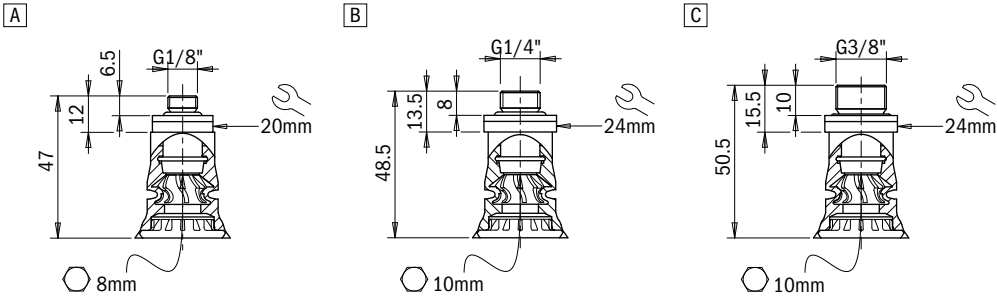

Identification codes			
Drawing	Alphanumeric code	Suction cups	Order code
A	VG.BPG30FSI.40	VG.BPG30 suction cup, FDA-compliant silicone, 40 Shore	2323086

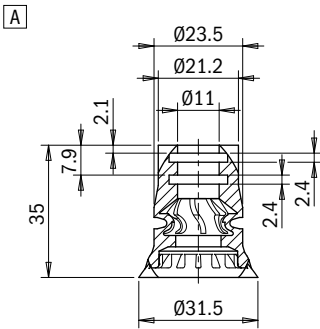

Click for Pricing & Add to Cart



Identification codes			
Drawing	Alphanumeric code	Fittings	Order code
A	FT.G18M.E8	G1/8" male fitting	1900017
B	FT.G14M.E10	G1/4" male fitting	1900013
C	FT.G38M.E10	G3/8" male fitting	1900037

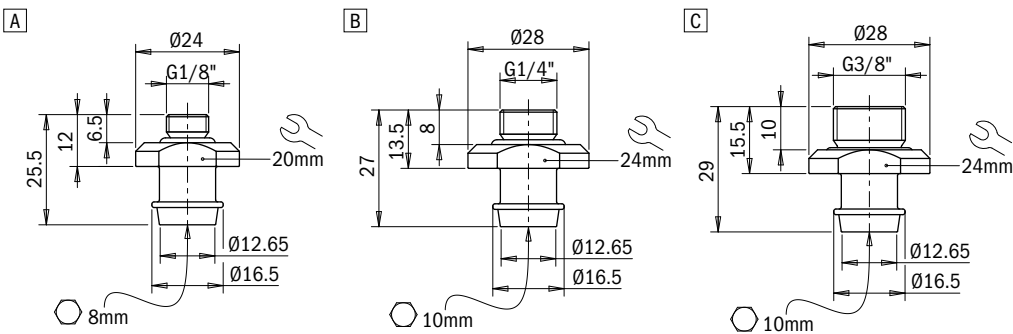

Suction cups / FDA-compliant silicone

VG.BPG41FSI multi-bellows suction cups in FDA-compliant silicone

- Suitable for handling bags, pouches and flexible packages for solids and liquids
- Version with 1.5 bellows
- Suction cups in FDA-compliant silicone
- Ideal for handling unpackaged food products such as pralines or biscuits with porous and uneven surfaces
- Reinforced bellows for higher grip stability
- The lip of the suction cup has been designed to maximise the grip and allow perfect adhesion even on wrinkles without damaging the grip surfaces

NEW



Application example



Technical data

Material	Lifting force [N] perpendicular to the surface, at various vacuum levels			Lifting force [N] parallel to the surface, at various vacuum levels			Volume [cm ³]	Min curve radius [mm]	Max vertical movement [mm]	Suction cup weight [g]
	-20 kPa	-50 kPa	-60 kPa	-20 kPa	-50 kPa	-60 kPa				
SIL 40 FDA	14	19.4	23.7	8.3	13	15.9	13.4	20.5	3.5	13.7

Technical features

Material	Color	Hardness	Temperature range
Silicone, FDA SIL	Transparent	40 Shore	-94 - +392 °F

Identification codes			
Drawing	Alphanumeric code	Suction cups with fitting	Order code
A	VG.BPG41FSI.40.G18M	VG.BPG41 suction cup, FDA-compliant silicone, 40 Shore, G1/8" male	2323089
B	VG.BPG41FSI.40.G14M	VG.BPG41 suction cup, FDA-compliant silicone, 40 Shore, G1/4" male	2323091
C	VG.BPG41FSI.40.G38M	VG.BPG41 suction cup, FDA-compliant silicone, 40 Shore, G3/8" male	2323092

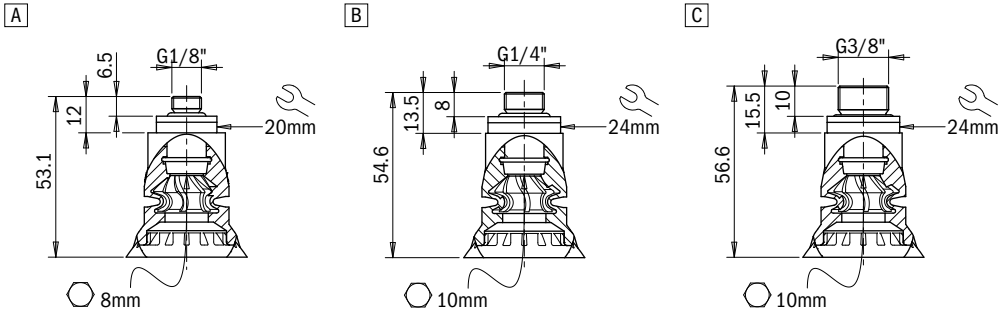

Identification codes			
Drawing	Alphanumeric code	Suction cups	Order code
A	VG.BPG41FSI.40	VG.BPG41 suction cup, FDA-compliant silicone, 40 Shore	2323090

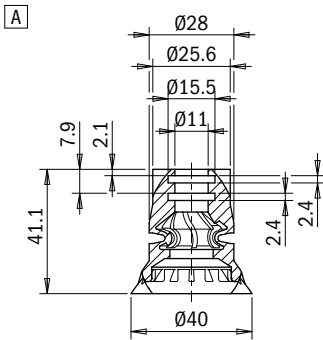

Identification codes			
Drawing	Alphanumeric code	Fittings	Order code
A	FT.G18M.E8	G1/8" male fitting	1900017
B	FT.G14M.E10	G1/4" male fitting	1900013
C	FT.G38M.E10	G3/8" male fitting	1900037

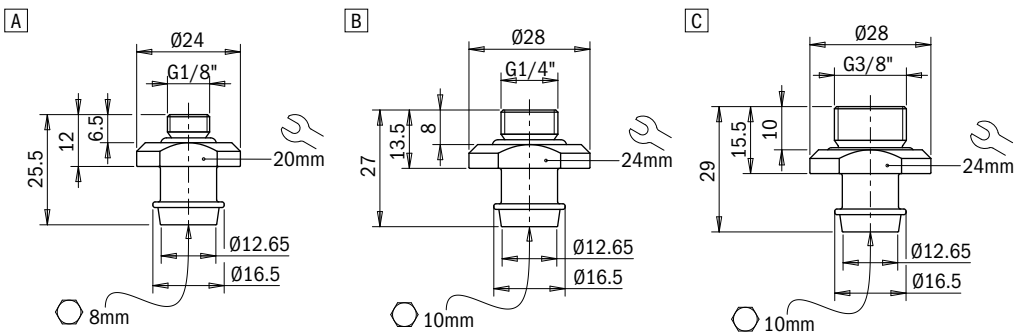

Suction cups / FDA-compliant silicone

VG.BPG48FSI multi-bellows suction cups in FDA-compliant silicone

- Suitable for handling bags, pouches and flexible packages for solids and liquids
- Version with 1.5 bellows
- Suction cups in FDA-compliant silicone
- Ideal for handling unpackaged food products such as pralines or biscuits with porous and uneven surfaces
- Reinforced bellows for higher grip stability
- The lip of the suction cup has been designed to maximise the grip and allow perfect adhesion even on wrinkles without damaging the grip surfaces

NEW



Application example

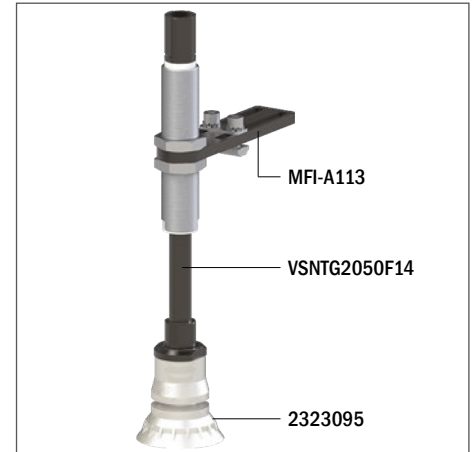

Technical data

Material	Lifting force [N] perpendicular to the surface, at various vacuum levels			Lifting force [N] parallel to the surface, at various vacuum levels			Volume [cm ³]	Min curve radius [mm]	Max vertical movement [mm]	Suction cup weight [g]
	-20 kPa	-50 kPa	-60 kPa	-20 kPa	-50 kPa	-60 kPa				
SIL 40 FDA	19.8	26	32.9	10.9	16.5	22	17.9	24	4	18.4

Technical features

Material	Color	Hardness	Temperature range
Silicone, FDA SIL	Transparent	40 Shore	-94 - +392 °F

Identification codes			
Drawing	Alphanumeric code	Suction cups with fitting	Order code
A	VG.BPG48FSI.40.G18M	VG.BPG48 suction cup, FDA-compliant silicone, 40 Shore, G1/8" male	2323093
B	VG.BPG48FSI.40.G14M	VG.BPG48 suction cup, FDA-compliant silicone, 40 Shore, G1/4" male	2323095
C	VG.BPG48FSI.40.G38M	VG.BPG48 suction cup, FDA-compliant silicone, 40 Shore, G3/8" male	2323096

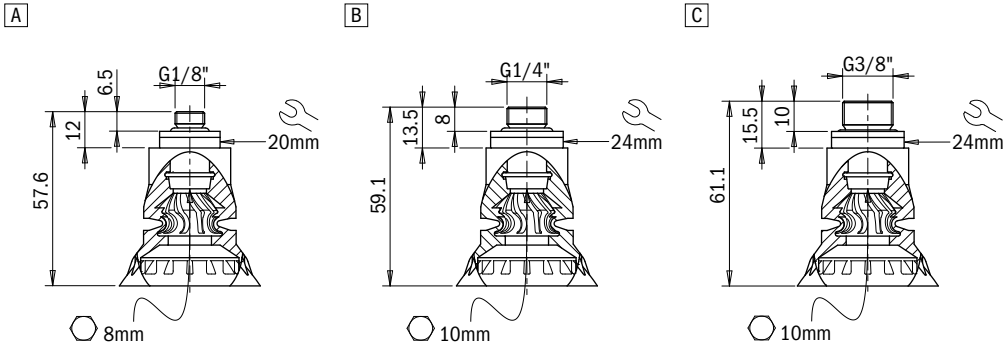

Identification codes			
Drawing	Alphanumeric code	Suction cups	Order code
A	VG.BPG48FSI.40	VG.BPG48 suction cup, FDA-compliant silicone, 40 Shore	2323094

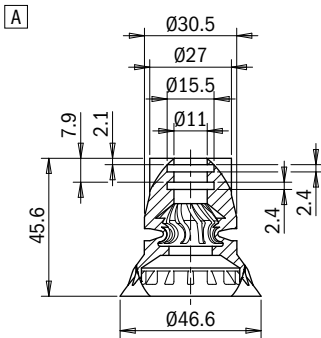

Identification codes			
Drawing	Alphanumeric code	Fittings	Order code
A	FT.G18M.E8	G1/8" male fitting	1900017
B	FT.G14M.E10	G1/4" male fitting	1900013
C	FT.G38M.E10	G3/8" male fitting	1900037

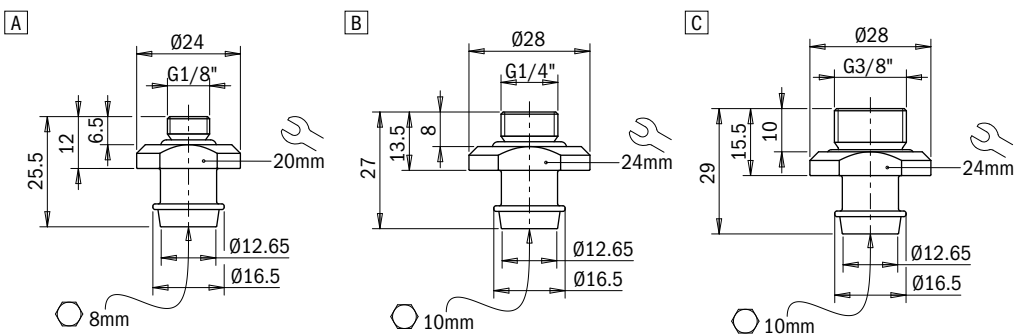

Suction cups / FDA-compliant silicone

VG.BPG55FSI multi-bellows suction cups in FDA-compliant silicone

- Suitable for handling bags, pouches and flexible packages for solids and liquids
- Version with 1.5 bellows
- Suction cups in FDA-compliant silicone
- Ideal for handling unpackaged food products such as pralines or biscuits with porous and uneven surfaces
- Reinforced bellows for higher grip stability
- The lip of the suction cup has been designed to maximise the grip and allow perfect adhesion even on wrinkles without damaging the grip surfaces

NEW



Fixing example

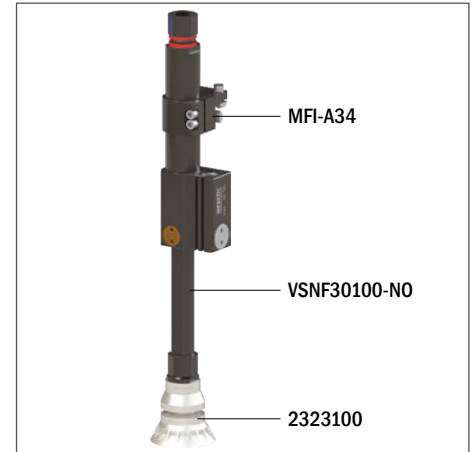

Technical data

Material	Lifting force [N] perpendicular to the surface, at various vacuum levels			Lifting force [N] parallel to the surface, at various vacuum levels			Volume [cm ³]	Min curve radius [mm]	Max vertical movement [mm]	Suction cup weight [g]
	-20 kPa	-50 kPa	-60 kPa	-20 kPa	-50 kPa	-60 kPa				
SIL 40 FDA	22	35.8	48.7	15.2	22.3	31.2	31.8	27.5	5.3	32.5

Technical features

Material	Color	Hardness	Temperature range
Silicone, FDA SIL	Transparent	40 Shore	-94 - +392 °F

Identification codes			
Drawing	Alphanumeric code	Suction cups with fitting	Order code
A	VG.BPG55FSI.40.G18M	VG.BPG55 suction cup, FDA-compliant silicone, 40 Shore, G1/8" male	2323097
B	VG.BPG55FSI.40.G14M	VG.BPG55 suction cup, FDA-compliant silicone, 40 Shore, G1/4" male	2323099
C	VG.BPG55FSI.40.G38M	VG.BPG55 suction cup, FDA-compliant silicone, 40 Shore, G3/8" male	2323100

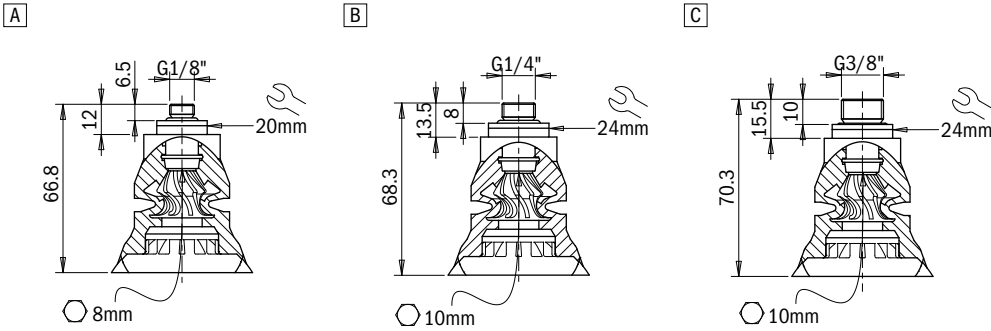

Identification codes			
Drawing	Alphanumeric code	Suction cups	Order code
A	VG.BPG55FSI.40	VG.BPG55 suction cup, FDA-compliant silicone, 40 Shore	2323098

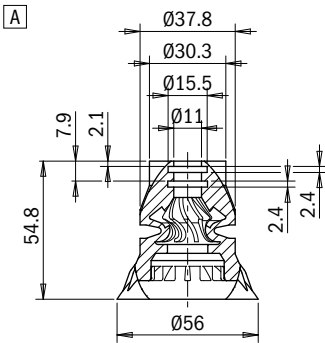

Identification codes			
Drawing	Alphanumeric code	Fittings	Order code
A	FT.G18M.E8	G1/8" male fitting	1900017
B	FT.G14M.E10	G1/4" male fitting	1900013
C	FT.G38M.E10	G3/8" male fitting	1900037

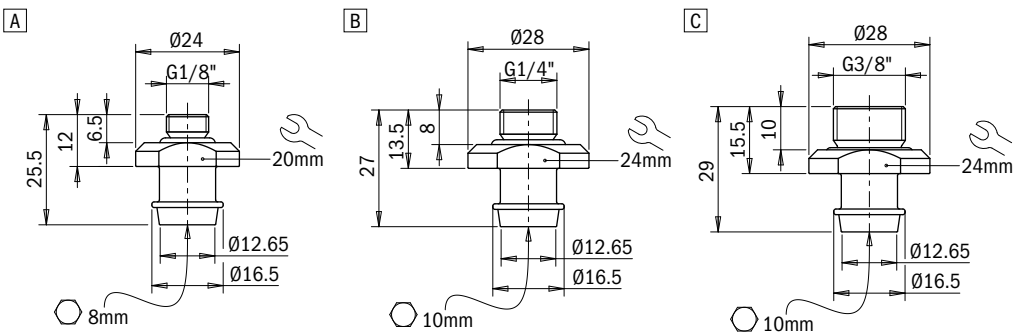

Suction cups / FDA-compliant silicone

VG.LPG30F multi-bellows suction cups in FDA-compliant silicone

- Suitable for handling bags, pouches and flexible packages for solids and liquids
- Version with 3.5 bellows
- Suction cups in FDA-compliant silicone
- Reinforced bellows for higher grip stability
- The lip of the suction cup has been designed to maximise the grip and allow perfect adhesion even on wrinkles without damaging the grip surfaces

NEW



Application example

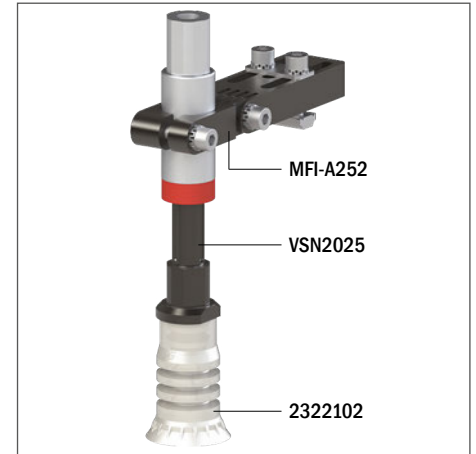

Technical data

Material	Lifting force [N] perpendicular to the surface, at various vacuum levels			Lifting force [N] parallel to the surface, at various vacuum levels			Volume [cm ³]	Min curve radius [mm]	Max vertical movement [mm]	Suction cup weight [g]
	-20 kPa	-50 kPa	-60 kPa	-20 kPa	-50 kPa	-60 kPa				
SIL 40 FDA	9.0	16.0	17.5	–	–	–	10.5	15	9	10.7

Technical features

Material	Color	Hardness	Temperature range
Silicone, FDA SIL	Transparent	40 Shore	-94 - +392 °F

Identification codes			
Drawing	Alphanumeric code	Suction cups with fitting	Order code
A	VG.LPG30F.40.G18M	VG.LPG30 suction cup, FDA-compliant silicone, 40 Shore, with internal insert, G1/8" male	2322102
B	VG.LPG30F.40.G14M	VG.LPG30 suction cup, FDA-compliant silicone, 40 Shore, with internal insert, G1/4" male	2322104
C	VG.LPG30F.40.G38M	VG.LPG30 suction cup, FDA-compliant silicone, 40 Shore, with internal insert, G3/8" male	2322105

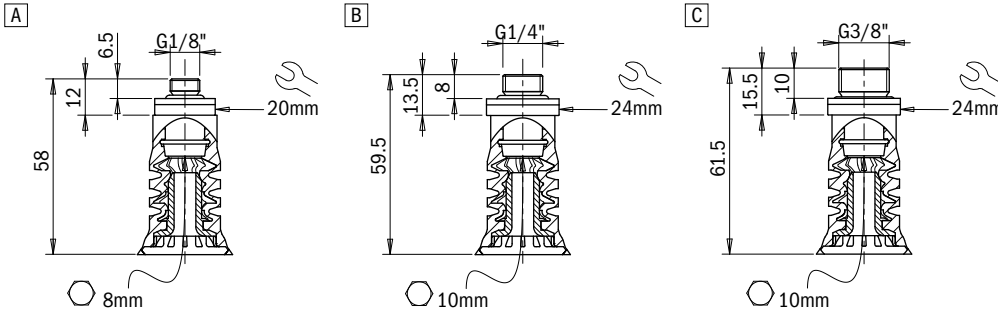

Identification codes			
Drawing	Alphanumeric code	Suction cups	Order code
A	VG.LPG30F.40	VG.LPG30 suction cup, FDA-compliant silicone, 40 Shore, with internal insert	2322103

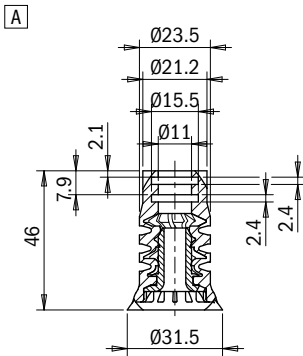

Identification codes			
Drawing	Alphanumeric code	Fittings	Order code
A	FT.G18M.E8	G1/8" male fitting	1900017
B	FT.G14M.E10	G1/4" male fitting	1900013
C	FT.G38M.E10	G3/8" male fitting	1900037

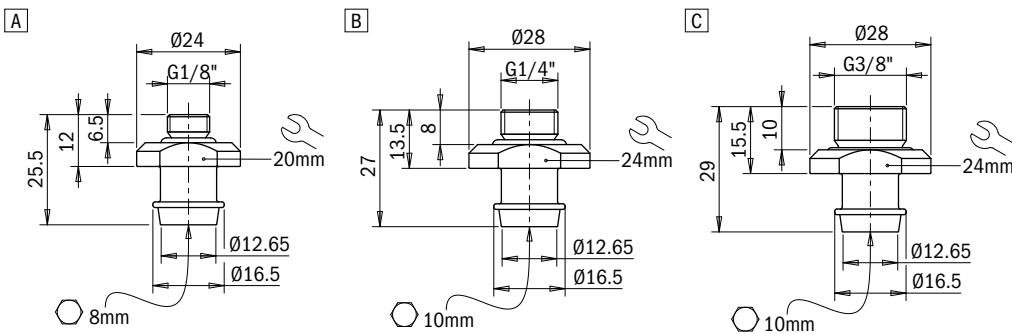

Identification codes		
Alphanumeric code	Insert	Order code
AC.LPG30	Spare insert for flow packs, size 30 mm in PA12 GB material	2322147

Suction cups / FDA-compliant silicone

VG.LPG41F multi-bellows suction cups in FDA-compliant silicone

- Suitable for handling bags, pouches and flexible packages for solids and liquids
- Version with 3.5 bellows
- Suction cups in FDA-compliant silicone
- Reinforced bellows for higher grip stability
- The lip of the suction cup has been designed to maximise the grip and allow perfect adhesion even on wrinkles without damaging the grip surfaces

NEW



Application example

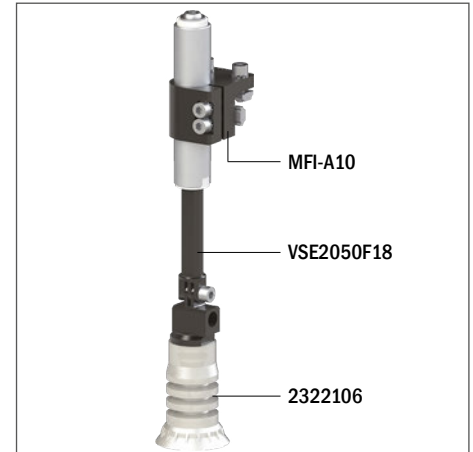

Technical data

Material	Lifting force [N] perpendicular to the surface, at various vacuum levels			Lifting force [N] parallel to the surface, at various vacuum levels			Volume [cm ³]	Min curve radius [mm]	Max vertical movement [mm]	Suction cup weight [g]
	-20 kPa	-50 kPa	-60 kPa	-20 kPa	-50 kPa	-60 kPa				
SIL 40 FDA	13	18.6	22.5	–	–	–	17.3	20.5	10.5	17.7

Technical features

Material	Color	Hardness	Temperature range
Silicone, FDA SIL	Transparent	40 Shore	-94 - +392 °F

Identification codes			
Drawing	Alphanumeric code	Suction cups with fitting	Order code
A	VG.LPG41F.40.G18M	VG.LPG41 suction cup, FDA-compliant silicone, 40 Shore, with internal insert, G1/8" male	2322106
B	VG.LPG41F.40.G14M	VG.LPG41 suction cup, FDA-compliant silicone, 40 Shore, with internal insert, G1/4" male	2322108
C	VG.LPG41F.40.G38M	VG.LPG41 suction cup, FDA-compliant silicone, 40 Shore, with internal insert, G3/8" male	2322109

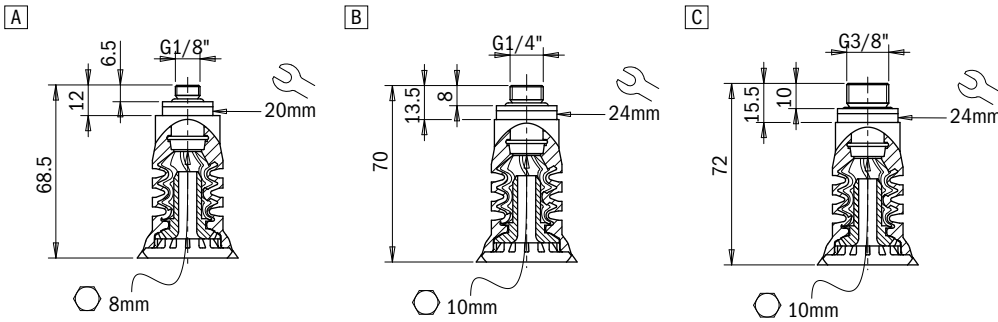

Identification codes			
Drawing	Alphanumeric code	Suction cups	Order code
A	VG.LPG41F.40	VG.LPG41 suction cup, FDA-compliant silicone, 40 Shore, with internal insert	2322107

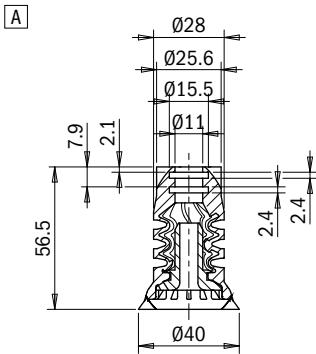

Identification codes			
Drawing	Alphanumeric code	Fittings	Order code
A	FT.G18M.E8	G1/8" male fitting	1900017
B	FT.G14M.E10	G1/4" male fitting	1900013
C	FT.G38M.E10	G3/8" male fitting	1900037

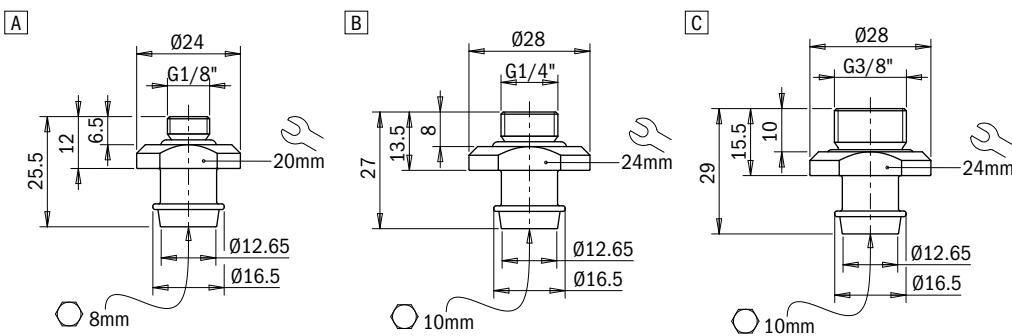

Identification codes		
Alphanumeric code	Insert	Order code
AC.LPG41	Spare insert for flow packs, size 41 mm in PA12 GB material	2322148

Suction cups / FDA-compliant silicone

VG.LPG48F multi-bellows suction cups in FDA-compliant silicone

- Suitable for handling bags, pouches and flexible packages for solids and liquids
- Version with 3.5 bellows
- Suction cups in FDA-compliant silicone
- Reinforced bellows for higher grip stability
- The lip of the suction cup has been designed to maximise the grip and allow perfect adhesion even on wrinkles without damaging the grip surfaces

NEW



Application example



Technical data

Material	Lifting force [N] perpendicular to the surface, at various vacuum levels			Lifting force [N] parallel to the surface, at various vacuum levels			Volume [cm ³]	Min curve radius [mm]	Max vertical movement [mm]	Suction cup weight [g]
	-20 kPa	-50 kPa	-60 kPa	-20 kPa	-50 kPa	-60 kPa				
SIL 40 FDA	19.6	25	32.5	–	–	–	23.7	24	12	24

Technical features

Material	Color	Hardness	Temperature range
Silicone, FDA SIL	Transparent	40 Shore	-94 - +392 °F

Identification codes			
Drawing	Alphanumeric code	Suction cups with fitting	Order code
A	VG.LPG48F.40.G18M	VG.LPG48 suction cup, FDA-compliant silicone, 40 Shore, with internal insert, G1/8" male	2322110
B	VG.LPG48F.40.G14M	VG.LPG48 suction cup, FDA-compliant silicone, 40 Shore, with internal insert, G1/4" male	2322112
C	VG.LPG48F.40.G38M	VG.LPG48 suction cup, FDA-compliant silicone, 40 Shore, with internal insert, G3/8" male	2322113

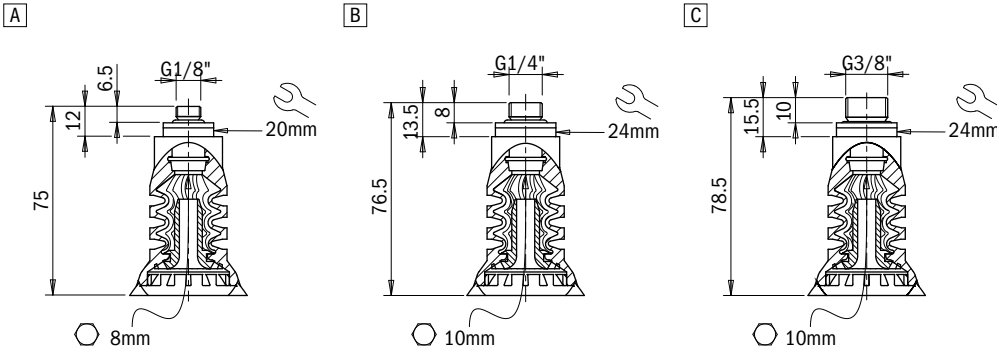

Identification codes			
Drawing	Alphanumeric code	Suction cups	Order code
A	VG.LPG48F.40	VG.LPG48 suction cup, FDA-compliant silicone, 40 Shore, with internal insert	2322111

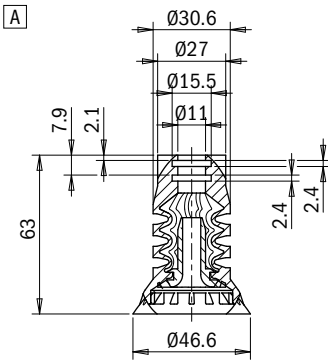

Click for Pricing & Add to Cart



Identification codes			
Drawing	Alphanumeric code	Fittings	Order code
A	FT.G18M.E8	G1/8" male fitting	1900017
B	FT.G14M.E10	G1/4" male fitting	1900013
C	FT.G38M.E10	G3/8" male fitting	1900037

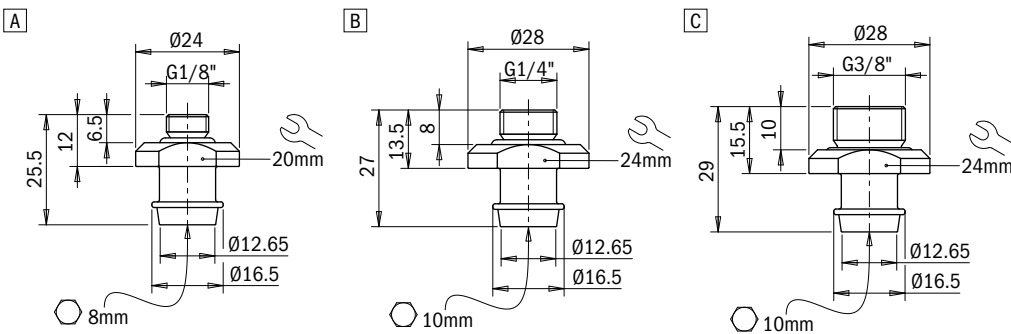

Identification codes		
Alphanumeric code	Insert	Order code
AC.LPG48	Spare insert for flow packs, size 48 mm in PA12 GB material	2322149

Suction cups / FDA-compliant silicone

VG.LPG30FSI multi-bellows suction cups in FDA-compliant silicone

- Suitable for handling bags, pouches and flexible packages for solids and liquids
- Version with 3.5 bellows
- Suction cups in FDA-compliant silicone
- Ideal for handling unpackaged food products such as pralines or biscuits with porous and uneven surfaces
- Reinforced bellows for higher grip stability
- The lip of the suction cup has been designed to maximise the grip and allow perfect adhesion even on wrinkles without damaging the grip surfaces

NEW



Application example

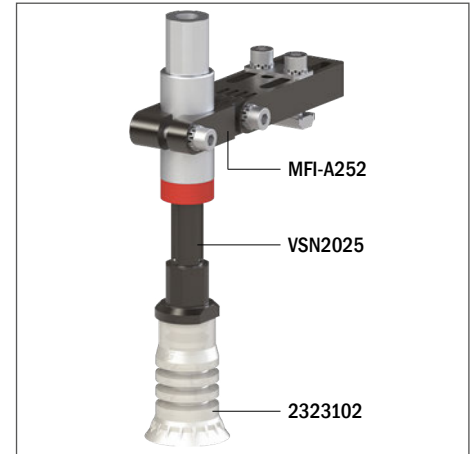

Technical data

Material	Lifting force [N] perpendicular to the surface, at various vacuum levels			Lifting force [N] parallel to the surface, at various vacuum levels			Volume [cm ³]	Min curve radius [mm]	Max vertical movement [mm]	Suction cup weight [g]
	-20 kPa	-50 kPa	-60 kPa	-20 kPa	-50 kPa	-60 kPa				
SIL 40 FDA	9.0	16.0	17.5	–	–	–	10.5	15	9	10.7

Technical features

Material	Color	Hardness	Temperature range
Silicone, FDA SIL	Transparent	40 Shore	-94 - +392 °F

Identification codes

Drawing	Alphanumeric code	Suction cups with fitting	Order code
A	VG.LPG30FSI.40.G18M	VG.LPG30 suction cup, FDA-compliant silicone, 40 Shore, G1/8" male	2323102
B	VG.LPG30FSI.40.G14M	VG.LPG30 suction cup, FDA-compliant silicone, 40 Shore, G1/4" male	2323104
C	VG.LPG30FSI.40.G38M	VG.LPG30 suction cup, FDA-compliant silicone, 40 Shore, G3/8" male	2323105

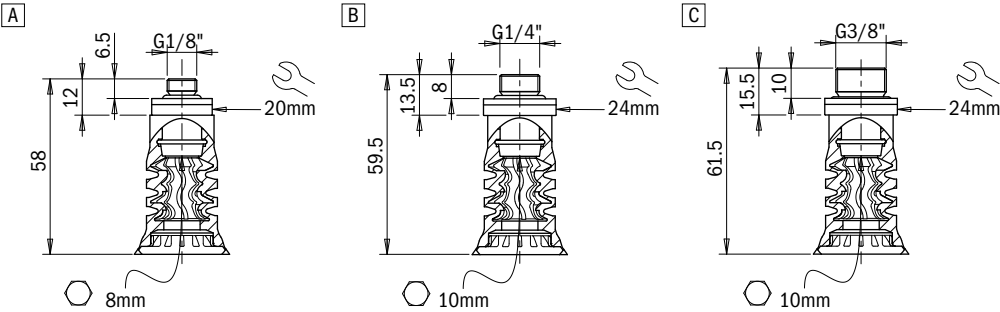

Identification codes

Drawing	Alphanumeric code	Suction cups	Order code
A	VG.LPG30FSI.40	VG.LPG30 suction cup, FDA-compliant silicone, 40 Shore	2323103

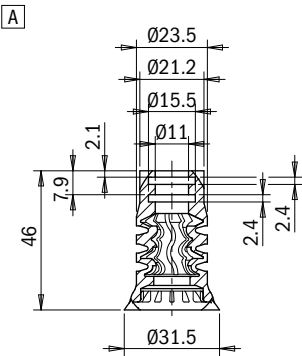

Identification codes

Drawing	Alphanumeric code	Fittings	Order code
A	FT.G18M.E8	G1/8" male fitting	1900017
B	FT.G14M.E10	G1/4" male fitting	1900013
C	FT.G38M.E10	G3/8" male fitting	1900037

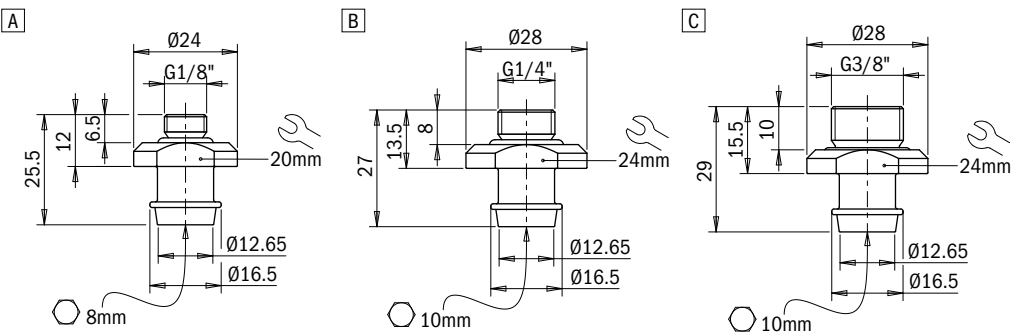

Suction cups / FDA-compliant silicone

VG.LPG41FSI multi-bellows suction cups in FDA-compliant silicone

- Suitable for handling bags, pouches and flexible packages for solids and liquids
- Version with 3.5 bellows
- Suction cups in FDA-compliant silicone
- Ideal for handling unpackaged food products such as pralines or biscuits with porous and uneven surfaces
- Reinforced bellows for higher grip stability
- The lip of the suction cup has been designed to maximise the grip and allow perfect adhesion even on wrinkles without damaging the grip surfaces

NEW



Application example

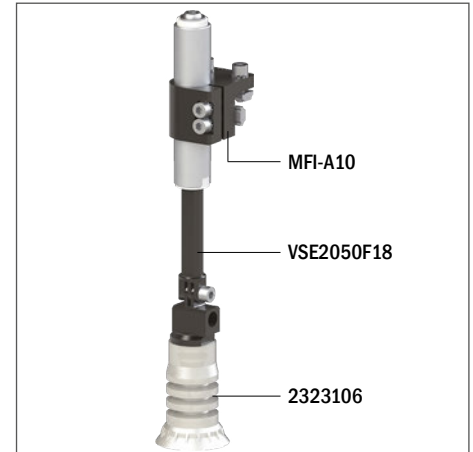

Technical data

Material	Lifting force [N] perpendicular to the surface, at various vacuum levels			Lifting force [N] parallel to the surface, at various vacuum levels			Volume [cm ³]	Min curve radius [mm]	Max vertical movement [mm]	Suction cup weight [g]
	-20 kPa	-50 kPa	-60 kPa	-20 kPa	-50 kPa	-60 kPa				
SIL 40 FDA	13	18.6	22.5	–	–	–	17.3	20.5	10.5	17.7

Technical features

Material	Color	Hardness	Temperature range
Silicone, FDA SIL	Transparent	40 Shore	-94 - +392 °F

Identification codes			
Drawing	Alphanumeric code	Suction cups with fitting	Order code
A	VG.LPG41FSI.40.G18M	VG.LPG41 suction cup, FDA-compliant silicone, 40 Shore, G1/8" male	2323106
B	VG.LPG41FSI.40.G14M	VG.LPG41 suction cup, FDA-compliant silicone, 40 Shore, G1/4" male	2323108
C	VG.LPG41FSI.40.G38M	VG.LPG41 suction cup, FDA-compliant silicone, 40 Shore, G3/8" male	2323109

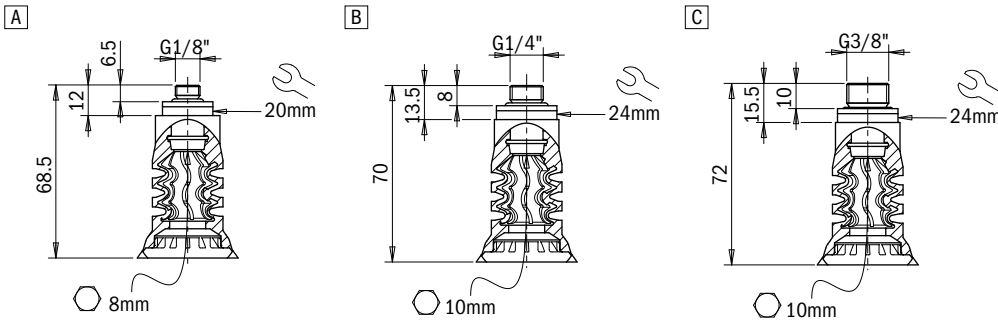

Identification codes			
Drawing	Alphanumeric code	Suction cups	Order code
A	VG.LPG41FSI.40	VG.LPG41 suction cup, FDA-compliant silicone, 40 Shore	2323107

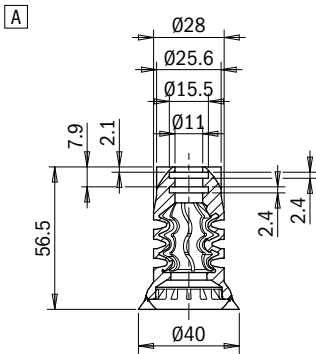

Identification codes			
Drawing	Alphanumeric code	Fittings	Order code
A	FT.G18M.E8	G1/8" male fitting	1900017
B	FT.G14M.E10	G1/4" male fitting	1900013
C	FT.G38M.E10	G3/8" male fitting	1900037

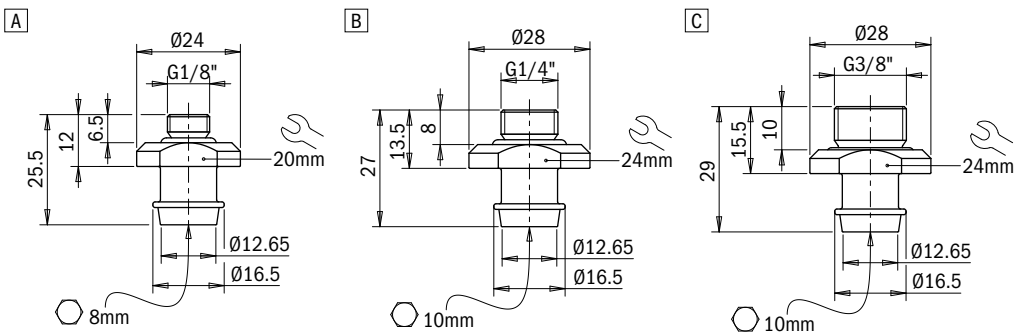

Suction cups / FDA-compliant silicone

VG.LPG48FSI multi-bellows suction cups in FDA-compliant silicone

- Suitable for handling bags, pouches and flexible packages for solids and liquids
- Version with 3.5 bellows
- Suction cups in FDA-compliant silicone
- Ideal for handling unpackaged food products such as pralines or biscuits with porous and uneven surfaces
- Reinforced bellows for higher grip stability
- The lip of the suction cup has been designed to maximise the grip and allow perfect adhesion even on wrinkles without damaging the grip surfaces

NEW



Application example



Technical data

Material	Lifting force [N] perpendicular to the surface, at various vacuum levels			Lifting force [N] parallel to the surface, at various vacuum levels			Volume [cm ³]	Min curve radius [mm]	Max vertical movement [mm]	Suction cup weight [g]
	-20 kPa	-50 kPa	-60 kPa	-20 kPa	-50 kPa	-60 kPa				
SIL 40 FDA	19.6	25	32.5	–	–	–	23.7	24	12	24

Technical features

Material	Color	Hardness	Temperature range
Silicone, FDA SIL	Transparent	40 Shore	-94 - +392 °F

Identification codes			
Drawing	Alphanumeric code	Suction cups with fitting	Order code
A	VG.LPG48FSI.40.G18M	VG.LPG48 suction cup, FDA-compliant silicone, 40 Shore, G1/8" male	2323110
B	VG.LPG48FSI.40.G14M	VG.LPG48 suction cup, FDA-compliant silicone, 40 Shore, G1/4" male	2323112
C	VG.LPG48FSI.40.G38M	VG.LPG48 suction cup, FDA-compliant silicone, 40 Shore, G3/8" male	2323113

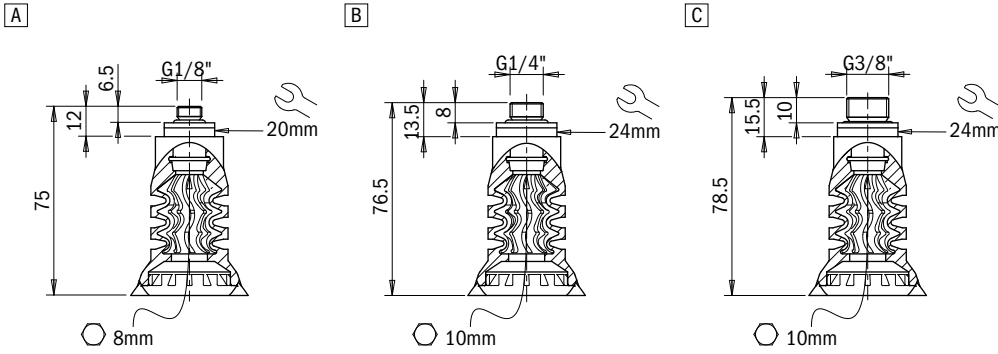

Identification codes			
Drawing	Alphanumeric code	Suction cups	Order code
A	VG.LPG48FSI.40	VG.LPG48 suction cup, FDA-compliant silicone, 40 Shore	2323111

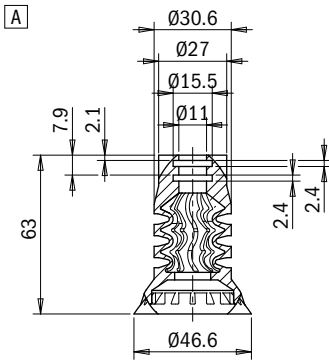

Identification codes			
Drawing	Alphanumeric code	Fittings	Order code
A	FT.G18M.E8	G1/8" male fitting	1900017
B	FT.G14M.E10	G1/4" male fitting	1900013
C	FT.G38M.E10	G3/8" male fitting	1900037

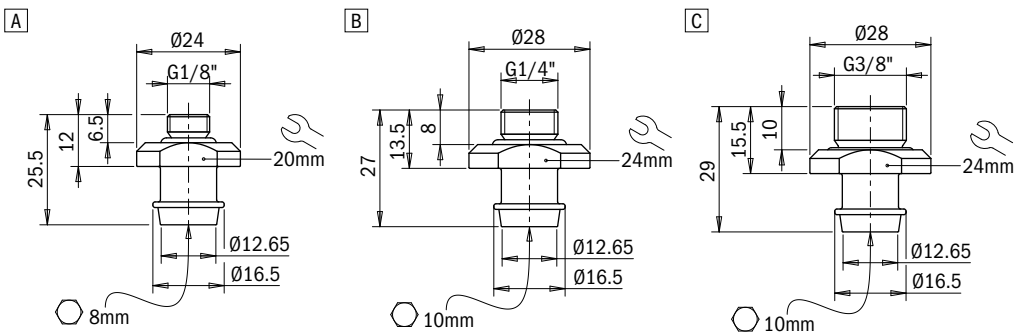

Suction cups / FDA-compliant silicone

VG.U6F flat FDA-compliant silicone suction cups

- Food-grade silicone compound (FDA-approved)
- Suitable for high working temperatures
- Suitable for objects with flat or slightly curved surfaces

Application example

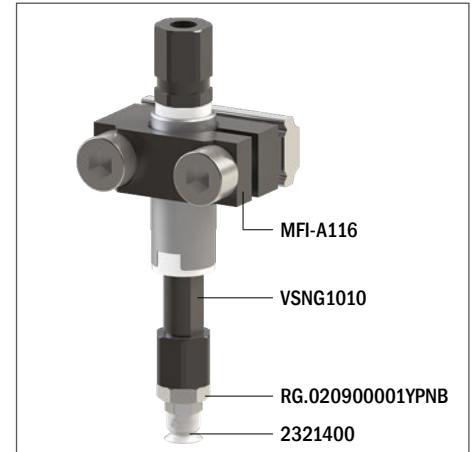

Technical data

Material	Lifting force [N] perpendicular to the surface, at various vacuum levels			Lifting force [N] parallel to the surface, at various vacuum levels			Volume [cm ³]	Min curve radius [mm]	Max vert. movement [mm]	Suction cup weight [g]
	-20 kPa	-60 kPa	-90 kPa	-20 kPa	-60 kPa	-90 kPa				
SIL 50 FDA	0.5	1.5	2.5	0.5	1.3	2.2	0.05	5	0.3	0.14

Technical features

Material	Color	Hardness	Temperature range
Silicone, FDA SIL	Transparent	50 Shore	-94 - +392 °F

Ordering information			
Drawing	Alphanumeric code	Suction cups with fitting	Order code
A	VG.U6F.50.M3M.E5	VG.U6 suction cup, FDA-compliant silicone, 50 Shore, M3 male, 5 mm hex	2321400
B	VG.U6F.50.M5M.E8	VG.U6 suction cup, FDA-compliant silicone, 50 Shore, M5 male, 8 mm hex	2321000

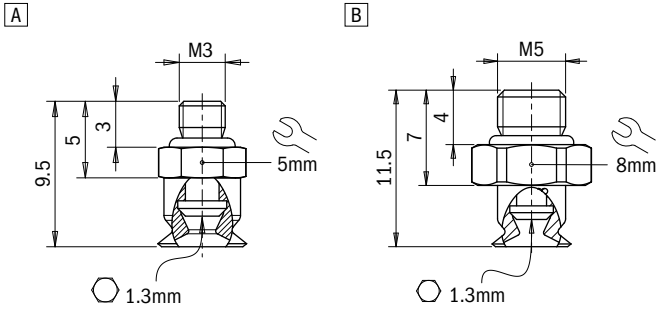

Ordering information			
Drawing	Alphanumeric code	Suction cups	Order code
A	VG.U6F.50	VG.U6 suction cup, FDA-compliant silicone, 50 Shore	2321401

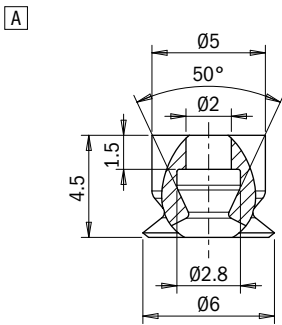

Ordering information			
Drawing	Alphanumeric code	Fittings	Order code
A	FT.M3M.E5	M3 male fitting, 5 mm hex	2321402
B	FT.M5M.E8.06	M5 male fitting, 8 mm hex	2321005

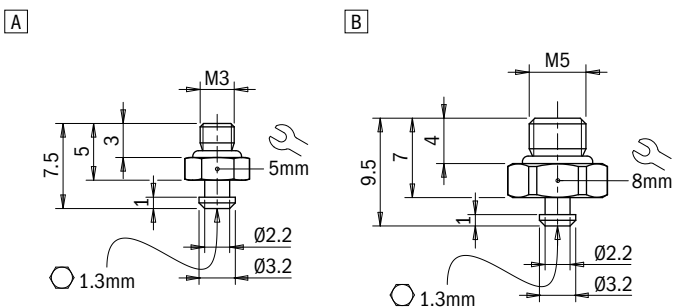

Suction cups / FDA-compliant silicone

VG.U9F flat FDA-compliant silicone suction cups

- Food-grade silicone compound (FDA-approved)
- Suitable for high working temperatures
- Suitable for objects with flat or slightly curved surfaces

Introduction

Vacuum theory

Suction cups

Vacuum pumps

Customised solutions

Suspensions

System accessories



Application example

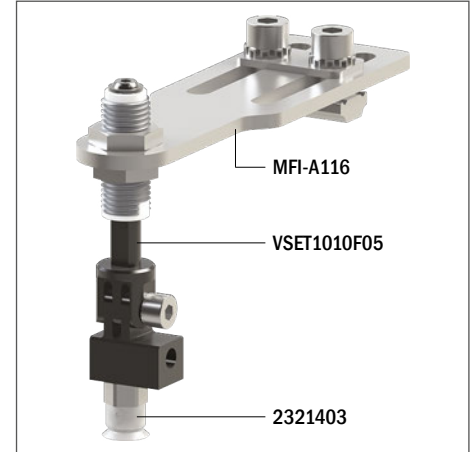

Technical data

Material	Lifting force [N] perpendicular to the surface, at various vacuum levels			Lifting force [N] parallel to the surface, at various vacuum levels			Volume [cm ³]	Min curve radius [mm]	Max vert. movement [mm]	Suction cup weight [g]
	-20 kPa	-60 kPa	-90 kPa	-20 kPa	-60 kPa	-90 kPa				
SIL 50 FDA	1	2.5	3.8	1	2.5	3.5	0.1	6	0.5	0.2

Technical features

Material	Color	Hardness	Temperature range
Silicone, FDA SIL	Transparent	50 Shore	-94 - +392 °F

Ordering information			
Drawing	Alphanumeric code	Suction cups with fitting	Order code
A	VG.U9F.50.M5M.E8	VG.U9 suction cup, FDA-compliant silicone, 50 Shore, M5 male, 8 mm hex	2321403

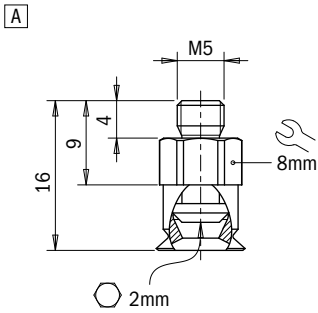

Ordering information			
Drawing	Alphanumeric code	Suction cups	Order code
A	VG.U9F.50	VG.U9 suction cup, FDA-compliant silicone, 50 Shore	2321404

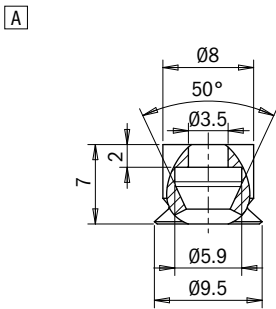

Ordering information			
Drawing	Alphanumeric code	Fittings	Order code
A	FT.M5M.E8.05	M5 male fitting, 8 mm hex	2321405

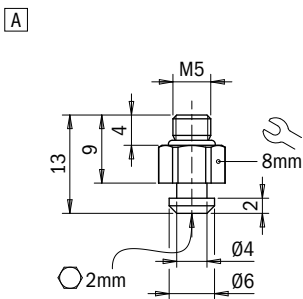

Suction cups / FDA-compliant silicone

VG.U11F flat FDA-compliant silicone suction cups

- Food-grade silicone compound (FDA-approved)
- Suitable for high working temperatures
- Suitable for objects with flat or slightly curved surfaces

Introduction

Vacuum theory

Suction cups

Vacuum pumps

Customised solutions

Suspensions

System accessories



Application example

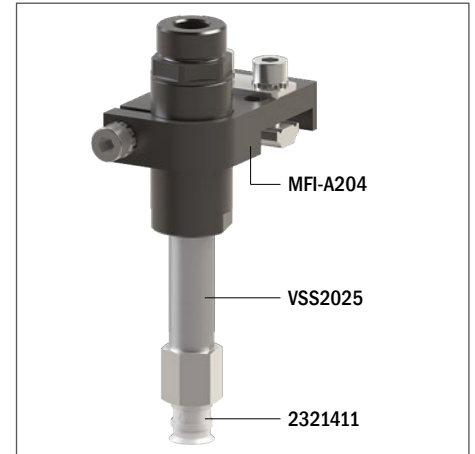

Technical data

Material	Lifting force [N] perpendicular to the surface, at various vacuum levels			Lifting force [N] parallel to the surface, at various vacuum levels			Volume [cm ³]	Min curve radius [mm]	Max vert. movement [mm]	Suction cup weight [g]
	-20 kPa	-60 kPa	-90 kPa	-20 kPa	-60 kPa	-90 kPa				
SIL 50 FDA	1.5	4.1	6.2	1.5	4.1	6.2	0.18	8	0.5	0.5

Technical features

Material	Color	Hardness	Temperature range
Silicone, FDA SIL	Transparent	50 Shore	-94 - +392 °F

Ordering information

Drawing	Alphanumeric code	Suction cups with fitting	Order code
A	VG.U11F.50.M5F.E8	VG.U11 suction cup, FDA-compliant silicone, 50 Shore, M5 female, 8 mm hex	2321406
B	VG.U11F.50.M5M.E8	VG.U11 suction cup, FDA-compliant silicone, 50 Shore, M5 male, 8 mm hex	2321409
C	VG.U11F.50.G18F.E13	VG.U11 suction cup, FDA-compliant silicone, 50 Shore, G1/8" female, 13 mm hex	2321411
D	VG.U11F.50.G18M.E13	VG.U11 suction cup, FDA-compliant silicone, 50 Shore, G1/8" male, 13 mm hex	2321413

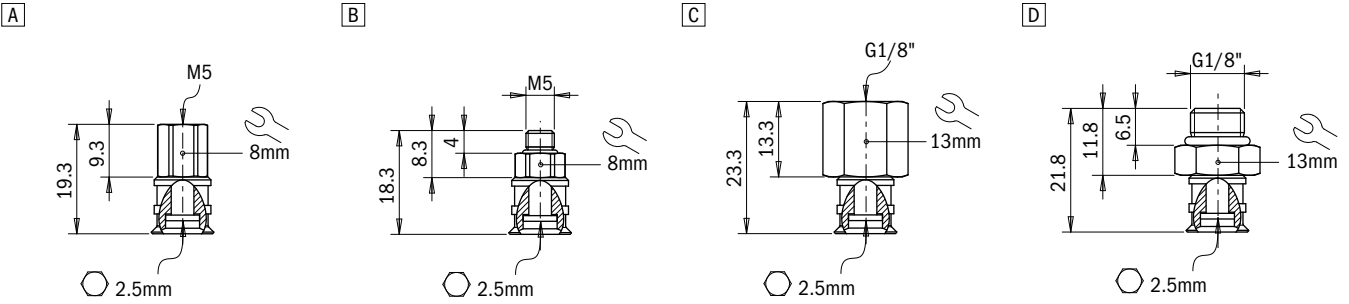

Ordering information

Drawing	Alphanumeric code	Suction cups	Order code
A	VG.U11F.50	VG.U11 suction cup, FDA-compliant silicone, 50 Shore	2321407

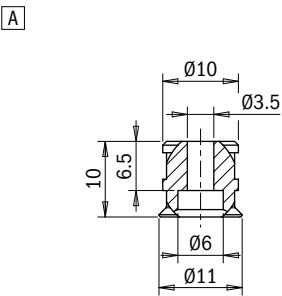

Click for Pricing & Add to Cart



Ordering information

Drawing	Alphanumeric code	Fittings	Order code
A	FT.M5F.E8	M5 female fitting, 8 mm hex	2321408
B	FT.M5M.E8	M5 male fitting, 8 mm hex	2321410
C	FT.G18F.E13	G1/8" female fitting, 13 mm hex	2321412
D	FT.G18M.E13	G1/8" male fitting, 13 mm hex	2321414

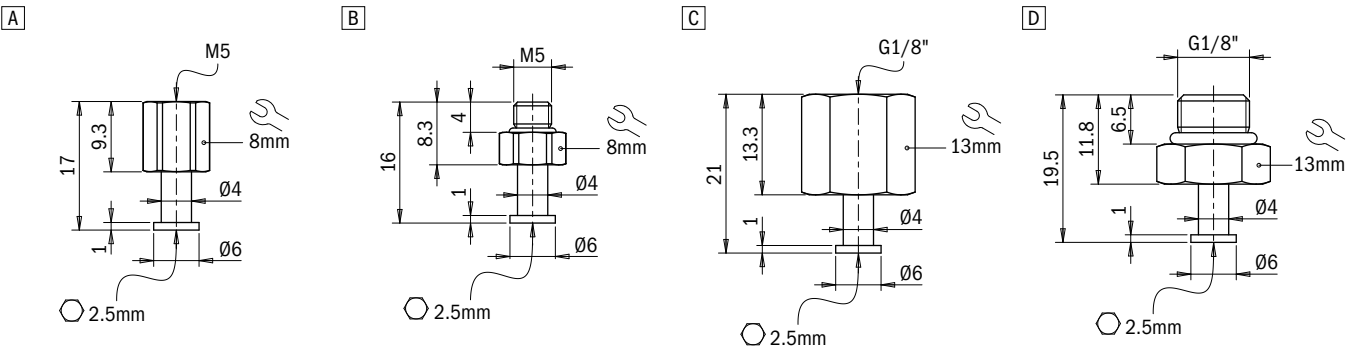

Suction cups / FDA-compliant silicone

VG.U16F flat FDA-compliant silicone suction cups

- Food-grade silicone compound (FDA-approved)
- Suitable for high working temperatures
- Suitable for objects with flat or slightly curved surfaces



Application example



Technical data

Material	Lifting force [N] perpendicular to the surface, at various vacuum levels			Lifting force [N] parallel to the surface, at various vacuum levels			Volume [cm ³]	Min curve radius [mm]	Max vert. movement [mm]	Suction cup weight [g]
	-20 kPa	-60 kPa	-90 kPa	-20 kPa	-60 kPa	-90 kPa				
SIL 50 FDA	3	8.5	11	3	8.5	11	0.5	8	1.5	0.6

Technical features

Material	Color	Hardness	Temperature range
Silicone, FDA SIL	Transparent	50 Shore	-94 - +392 °F

Ordering information

Drawing	Alphanumeric code	Suction cups with fitting	Order code
A	VG.U16F.50.M5F.E8	VG.U16 suction cup, FDA-compliant silicone, 50 Shore, M5 female, 8 mm hex	2321415
B	VG.U16F.50.M5M.E8	VG.U16 suction cup, FDA-compliant silicone, 50 Shore, M5 male, 8 mm hex	2321417
C	VG.U16F.50.G18F.E13	VG.U16 suction cup, FDA-compliant silicone, 50 Shore, G1/8" female, 13 mm hex	2321418
D	VG.U16F.50.G18M.E13	VG.U16 suction cup, FDA-compliant silicone, 50 Shore, G1/8" male, 13 mm hex	2321419

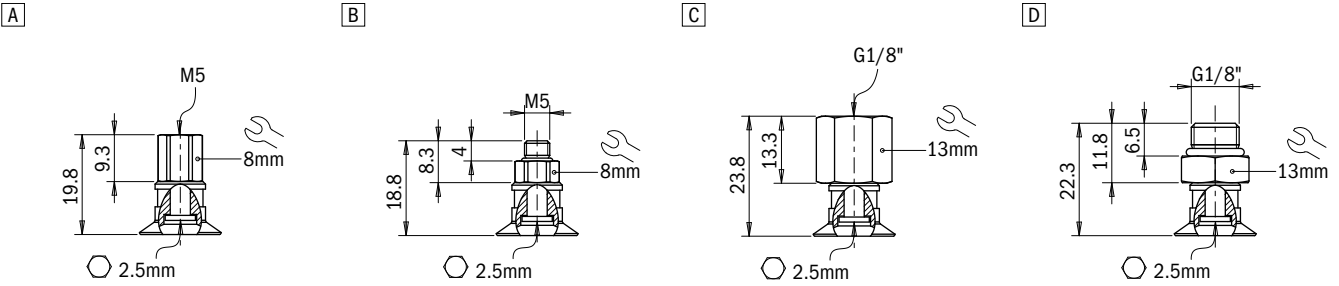

Identification codes

Drawing	Alphanumeric code	Suction cups	Order code
A	VG.U16F.50	VG.U16 suction cup, FDA-compliant silicone, 50 Shore	2321416

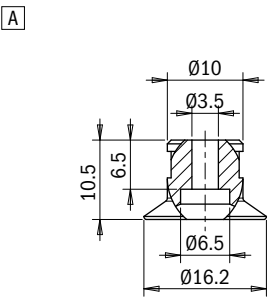

Identification codes

Drawing	Alphanumeric code	Fittings	Order code
A	FT.M5F.E8	M5 female fitting, 8 mm hex	2321408
B	FT.M5M.E8	M5 male fitting, 8 mm hex	2321410
C	FT.G18F.E13	G1/8" female fitting, 13 mm hex	2321412
D	FT.G18M.E13	G1/8" male fitting, 13 mm hex	2321414

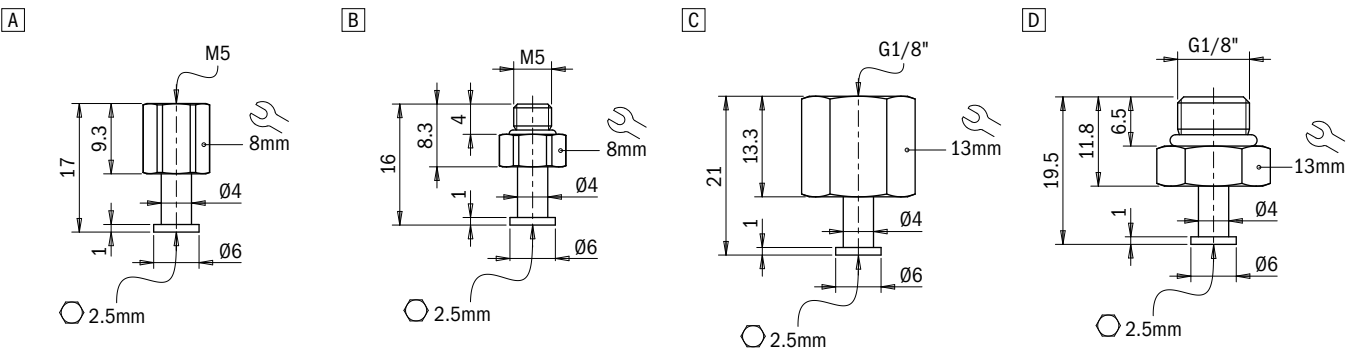

Suction cups / FDA-compliant silicone

VG.U22F flat FDA-compliant silicone suction cups

- Food-grade silicone compound (FDA-approved)
- Suitable for high working temperatures
- Suitable for objects with flat or slightly curved surfaces

Application example



Technical data

Material	Lifting force [N] perpendicular to the surface, at various vacuum levels			Lifting force [N] parallel to the surface, at various vacuum levels			Volume [cm ³]	Min curve radius [mm]	Max vert. movement [mm]	Suction cup weight [g]
	-20 kPa	-60 kPa	-90 kPa	-20 kPa	-60 kPa	-90 kPa				
SIL 50 FDA	5.6	14	20	6	14	20	1	13	2.5	1.1

Technical features

Material	Color	Hardness	Temperature range
Silicone, FDA SIL	Transparent	50 Shore	-94 - +392 °F

Ordering information

Drawing	Alphanumeric code	Suction cups with fitting	Order code
A	VG.U22F.50.G18F.E12	VG.U22 suction cup, FDA-compliant silicone, 50 Shore, G1/8" female, 12 mm hex	2321420
B	VG.U22F.50.G18M.E12	VG.U22 suction cup, FDA-compliant silicone, 50 Shore, G1/8" male, 12 mm hex	2321423
C	VG.U22F.50.G18F.E16	VG.U22 suction cup, FDA-compliant silicone, 50 Shore, G1/8" female, 16 mm hex	2321425
D	VG.U22F.50.G18M.E16	VG.U22 suction cup, FDA-compliant silicone, 50 Shore, G1/8" male, 16 mm hex	2321427
E	VG.U22F.50.G14F.E16	VG.U22 suction cup, FDA-compliant silicone, 50 Shore, G1/4" female, 16 mm hex	2321429
F	VG.U22F.50.G14M.E17	VG.U22 suction cup, FDA-compliant silicone, 50 Shore, G1/4" male, 17 mm hex	2321431

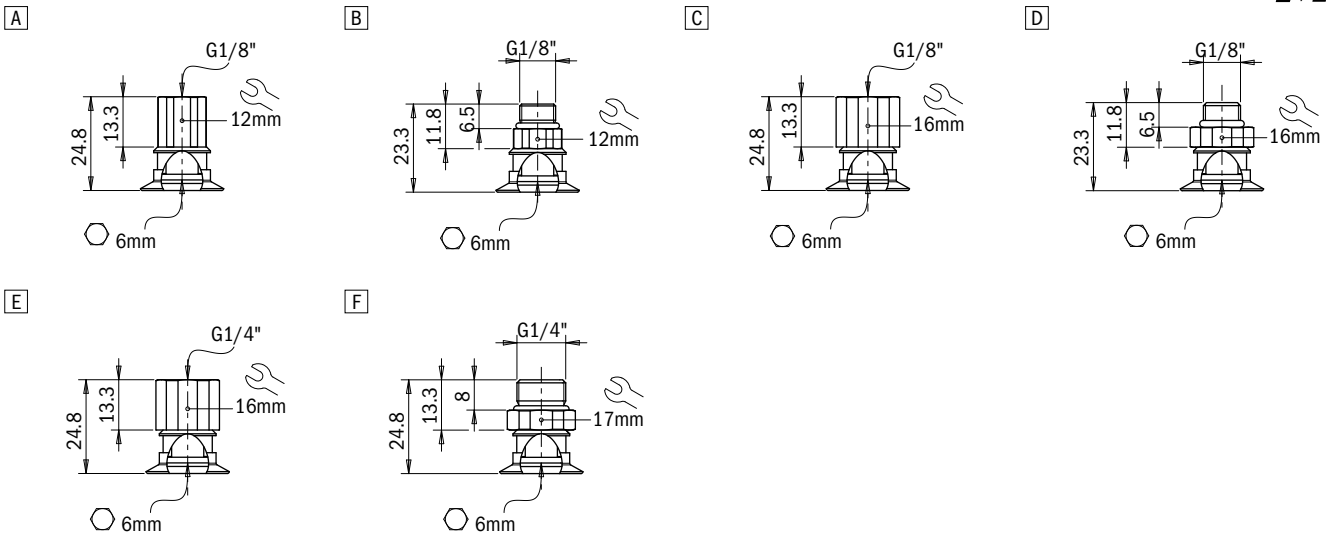

Ordering information

Drawing	Alphanumeric code	Suction cups	Order code
A	VG.U22F.50	VG.U22 suction cup, FDA-compliant silicone, 50 Shore	2321421

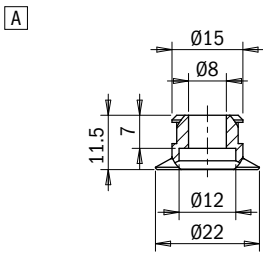

Ordering information

Drawing	Alphanumeric code	Fittings	Order code
A	FT.G18F.E12	G1/8" female fitting, 12 mm hex	2321422
B	FT.G18M.E12	G1/8" male fitting, 12 mm hex	2321424
C	FT.G18F.E16	G1/8" female fitting, 16 mm hex	2321426
D	FT.G18M.E16	G1/8" male fitting, 16 mm hex	2321428
E	FT.G14F.E16	G1/4" female fitting, 16 mm hex	2321430
F	FT.G14M.E17	G1/4" male fitting, 17 mm hex	2321432

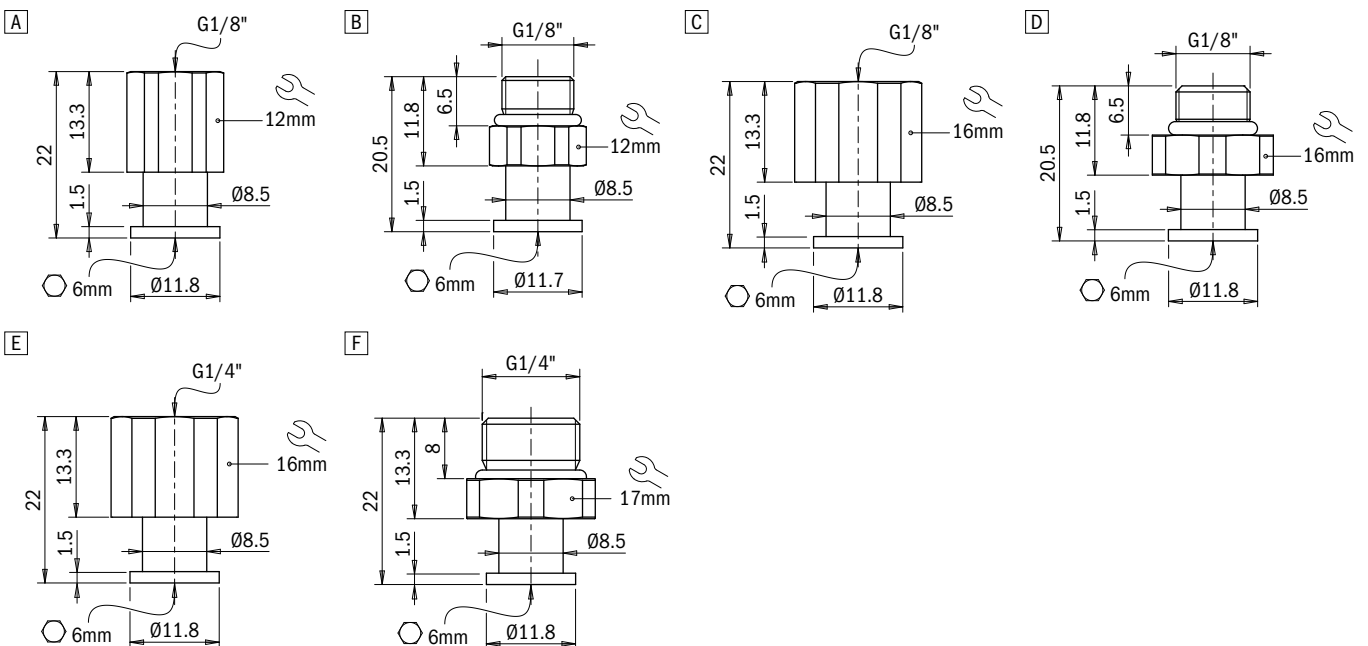

Suction cups / FDA-compliant silicone

VG.U33F flat FDA-compliant silicone suction cups

- Food-grade silicone compound (FDA-approved)
- Suitable for high working temperatures
- Suitable for objects with flat or slightly curved surfaces

Application example



Technical data

Material	Lifting force [N] perpendicular to the surface, at various vacuum levels			Lifting force [N] parallel to the surface, at various vacuum levels			Volume [cm ³]	Min curve radius [mm]	Max vert. movement [mm]	Suction cup weight [g]
	-20 kPa	-60 kPa	-90 kPa	-20 kPa	-60 kPa	-90 kPa				
SIL 50 FDA	11	29	38	8.5	15	12.5	2	20	3.5	2.4

Technical features

Material	Color	Hardness	Temperature range
Silicone, FDA SIL	Transparent	50 Shore	-94 - +392 °F

Ordering information

Drawing	Alphanumeric code	Suction cups with fitting	Order code
A	VG.U33F.50.G18F.E12	VG.U33 suction cup, FDA-compliant silicone, 50 Shore, G1/8" female, 12 mm hex	2321433
B	VG.U33F.50.G18M.E12	VG.U33 suction cup, FDA-compliant silicone, 50 Shore, G1/8" male, 12 mm hex	2321435
C	VG.U33F.50.G18F.E16	VG.U33 suction cup, FDA-compliant silicone, 50 Shore, G1/8" female, 16 mm hex	2321436
D	VG.U33F.50.G18M.E16	VG.U33 suction cup, FDA-compliant silicone, 50 Shore, G1/8" male, 16 mm hex	2321437
E	VG.U33F.50.G14F.E16	VG.U33 suction cup, FDA-compliant silicone, 50 Shore, G1/4" female, 16 mm hex	2321438
F	VG.U33F.50.G14M.E17	VG.U33 suction cup, FDA-compliant silicone, 50 Shore, G1/4" male, 17 mm hex	2321439

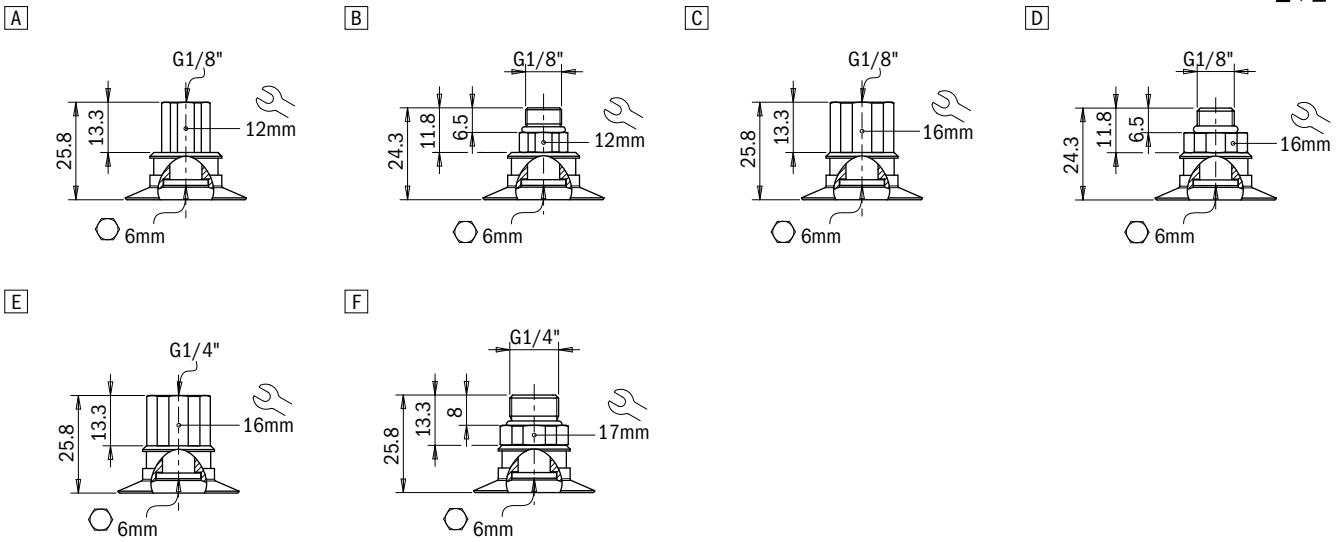

Ordering information

Drawing	Alphanumeric code	Suction cups	Order code
A	VG.U33F.50	VG.U33 suction cup, FDA-compliant silicone, 50 Shore	2321434

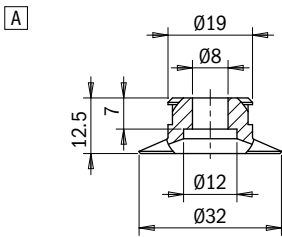

Ordering information

Drawing	Alphanumeric code	Fittings	Order code
A	FT.G18F.E12	G1/8" female fitting, 12 mm hex	2321422
B	FT.G18M.E12	G1/8" male fitting, 12 mm hex	2321424
C	FT.G18F.E16	G1/8" female fitting, 16 mm hex	2321426
D	FT.G18M.E16	G1/8" male fitting, 16 mm hex	2321428
E	FT.G14F.E16	G1/4" female fitting, 16 mm hex	2321430
F	FT.G14M.E17	G1/4" male fitting, 17 mm hex	2321432

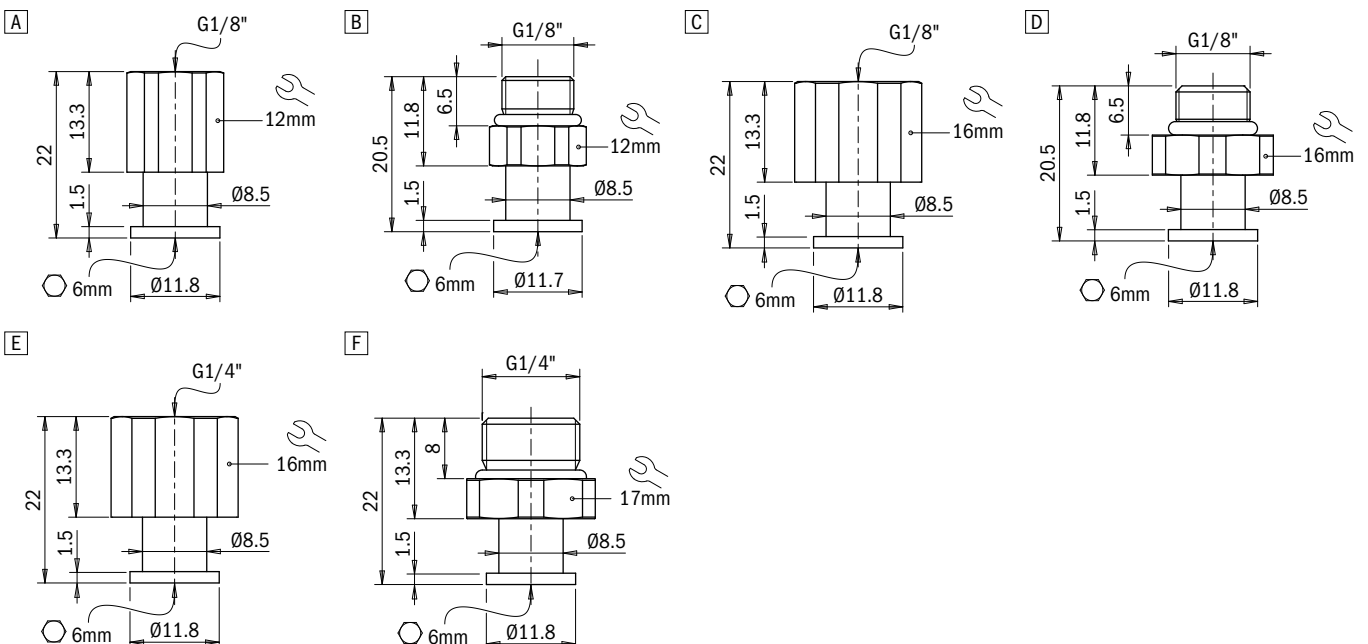

Suction cups / FDA-compliant silicone

VG.U42F flat FDA-compliant silicone suction cups

- Food-grade silicone compound (FDA-approved)
- Suitable for high working temperatures
- Suitable for objects with flat or slightly curved surfaces

Application example

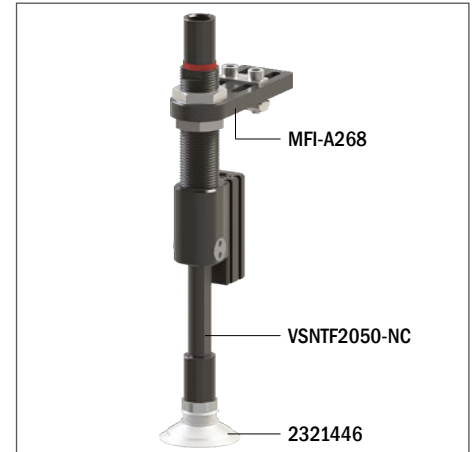

Technical data

Material	Lifting force [N] perpendicular to the surface, at various vacuum levels			Lifting force [N] parallel to the surface, at various vacuum levels			Volume [cm ³]	Min curve radius [mm]	Max vert. movement [mm]	Suction cup weight [g]
	-20 kPa	-60 kPa	-90 kPa	-20 kPa	-60 kPa	-90 kPa				
SIL 50 FDA	21	48.5	58	14	28	36	5.5	30	4.5	4.4

Technical features

Material	Color	Hardness	Temperature range
Silicone, FDA SIL	Transparent	50 Shore	-94 - +392 °F

Ordering information

Drawing	Alphanumeric code	Suction cups with fitting	Order code
A	VG.U42F.50.G18F.E12	VG.U42 suction cup, FDA-compliant silicone, 50 Shore, G1/8" female, 12 mm hex	2321440
B	VG.U42F.50.G18M.E12	VG.U42 suction cup, FDA-compliant silicone, 50 Shore, G1/8" male, 12 mm hex	2321442
C	VG.U42F.50.G18F.E16	VG.U42 suction cup, FDA-compliant silicone, 50 Shore, G1/8" female, 16 mm hex	2321443
D	VG.U42F.50.G18M.E16	VG.U42 suction cup, FDA-compliant silicone, 50 Shore, G1/8" male, 16 mm hex	2321444
E	VG.U42F.50.G14F.E16	VG.U42 suction cup, FDA-compliant silicone, 50 Shore, G1/4" female, 16 mm hex	2321445
F	VG.U42F.50.G14M.E17	VG.U42 suction cup, FDA-compliant silicone, 50 Shore, G1/4" male, 17 mm hex	2321446

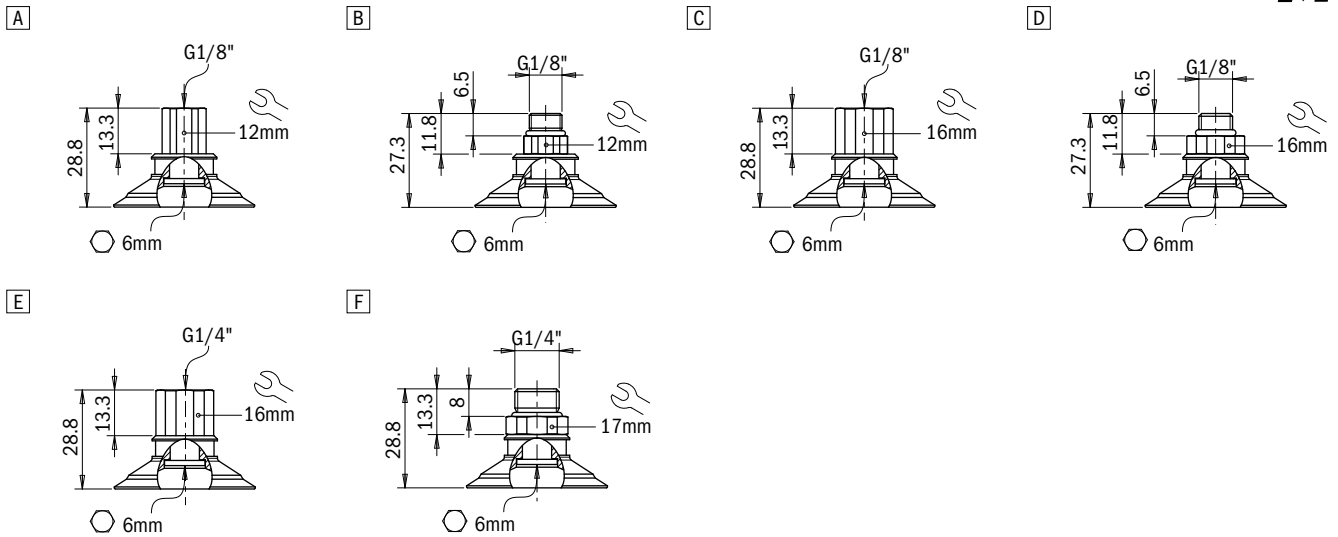

Ordering information

Drawing	Alphanumeric code	Suction cups	Order code
A	VG.U42F.50	VG.U42 suction cup, FDA-compliant silicone, 50 Shore	2321441

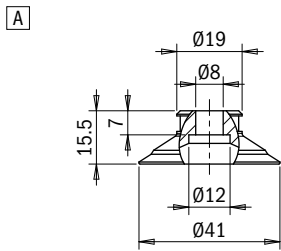

Ordering information

Drawing	Alphanumeric code	Fittings	Order code
A	FT.G18F.E12	G1/8" female fitting, 12 mm hex	2321422
B	FT.G18M.E12	G1/8" male fitting, 12 mm hex	2321424
C	FT.G18F.E16	G1/8" female fitting, 16 mm hex	2321426
D	FT.G18M.E16	G1/8" male fitting, 16 mm hex	2321428
E	FT.G14F.E16	G1/4" female fitting, 16 mm hex	2321430
F	FT.G14M.E17	G1/4" male fitting, 17 mm hex	2321432

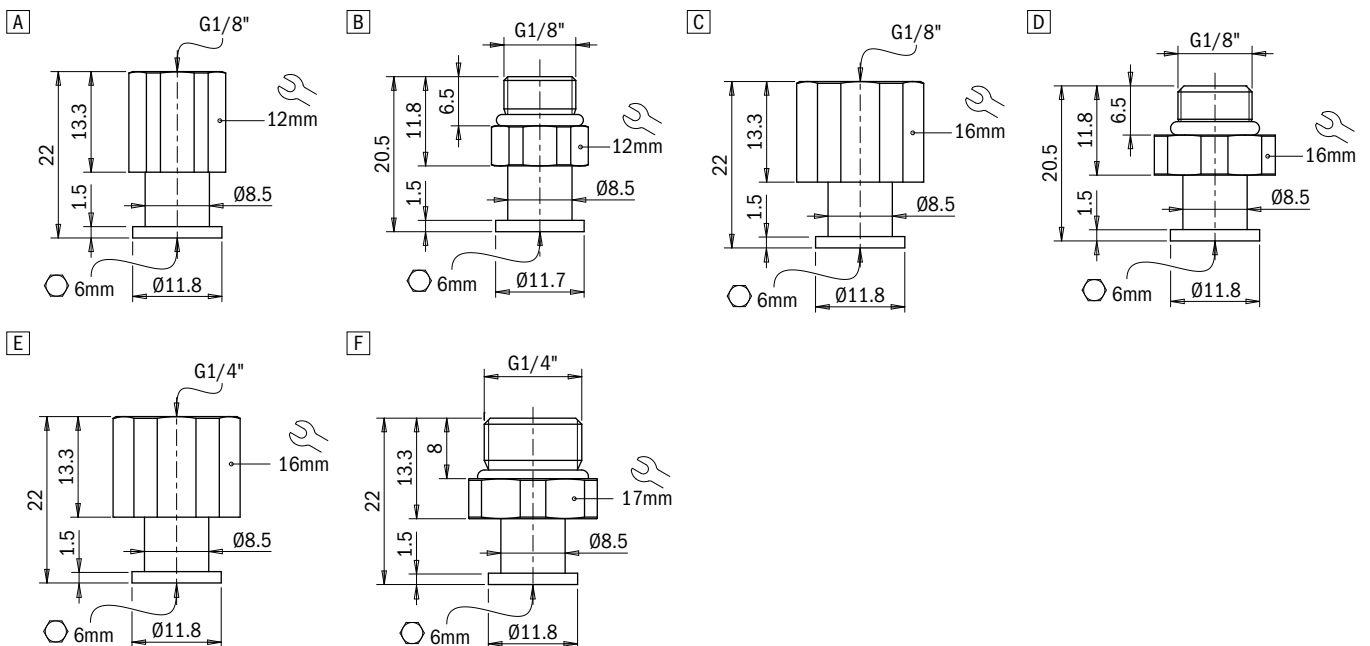

Suction cups / FDA-compliant silicone

VG.U53F flat FDA-compliant silicone suction cups

- Food-grade silicone compound (FDA-approved)
- Suitable for high working temperatures
- Suitable for objects with flat or slightly curved surfaces

Application example

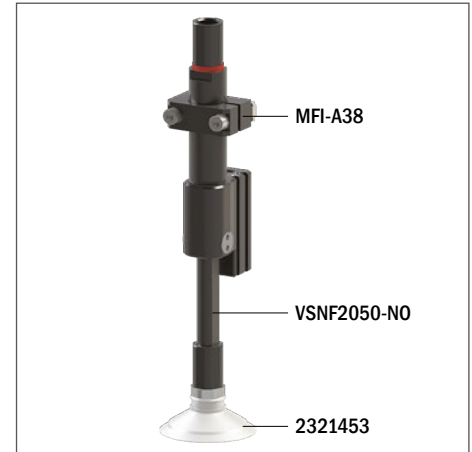

Technical data

Material	Lifting force [N] perpendicular to the surface, at various vacuum levels			Lifting force [N] parallel to the surface, at various vacuum levels			Volume [cm ³]	Min curve radius [mm]	Max vert. movement [mm]	Suction cup weight [g]
	-20 kPa	-60 kPa	-90 kPa	-20 kPa	-60 kPa	-90 kPa				
SIL 50 FDA	37	75	96	20	35	46	12	35	6	8

Technical features

Material	Color	Hardness	Temperature range
Silicone, FDA SIL	Transparent	50 Shore	-94 - +392 °F

Ordering information

Drawing	Alphanumeric code	Suction cups with fitting	Order code
A	VG.U53F.50.G18F.E12	VG.U53 suction cup, FDA-compliant silicone, 50 Shore, G1/8" female, 12 mm hex	2321447
B	VG.U53F.50.G18M.E12	VG.U53 suction cup, FDA-compliant silicone, 50 Shore, G1/8" male, 12 mm hex	2321449
C	VG.U53F.50.G18F.E16	VG.U53 suction cup, FDA-compliant silicone, 50 Shore, G1/8" female, 16 mm hex	2321450
D	VG.U53F.50.G18M.E16	VG.U53 suction cup, FDA-compliant silicone, 50 Shore, G1/8" male, 16 mm hex	2321451
E	VG.U53F.50.G14F.E16	VG.U53 suction cup, FDA-compliant silicone, 50 Shore, G1/4" female, 16 mm hex	2321452
F	VG.U53F.50.G14M.E17	VG.U53 suction cup, FDA-compliant silicone, 50 Shore, G1/4" male, 17 mm hex	2321453

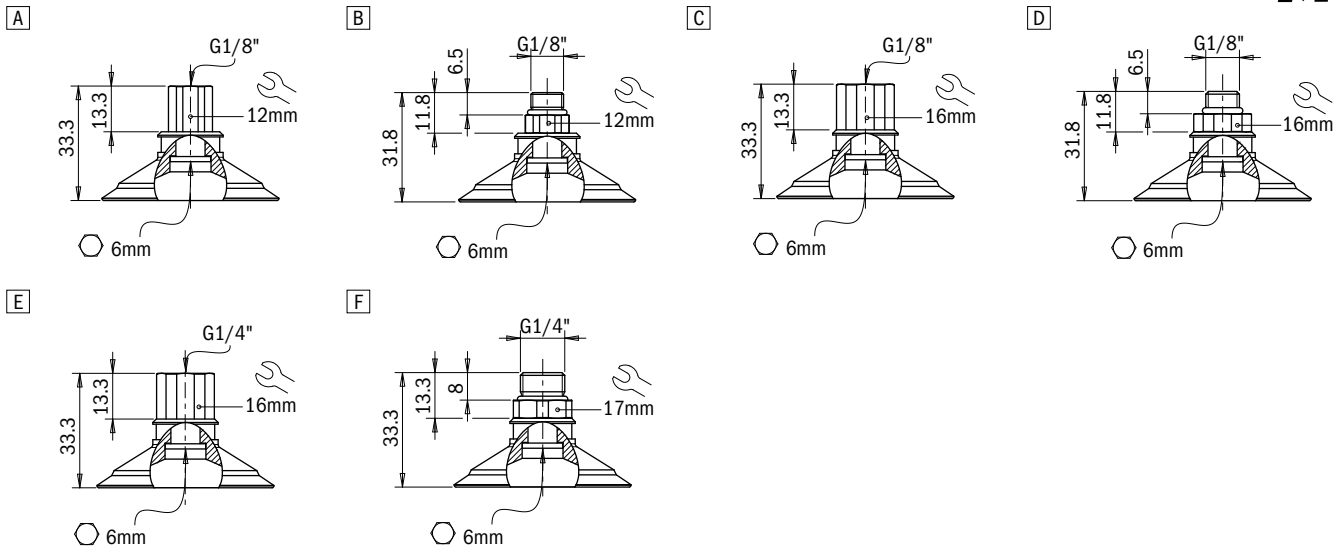

Ordering information

Drawing	Alphanumeric code	Suction cups	Order code
A	VG.U53F.50	VG.U53 suction cup, FDA-compliant silicone, 50 Shore	2321448

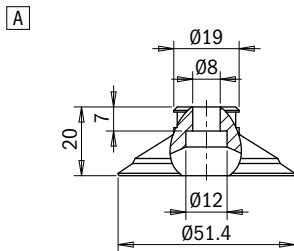

Ordering information

Drawing	Alphanumeric code	Fittings	Order code
A	FT.G18F.E12	G1/8" female fitting, 12 mm hex	2321422
B	FT.G18M.E12	G1/8" male fitting, 12 mm hex	2321424
C	FT.G18F.E16	G1/8" female fitting, 16 mm hex	2321426
D	FT.G18M.E16	G1/8" male fitting, 16 mm hex	2321428
E	FT.G14F.E16	G1/4" female fitting, 16 mm hex	2321430
F	FT.G14M.E17	G1/4" male fitting, 17 mm hex	2321432

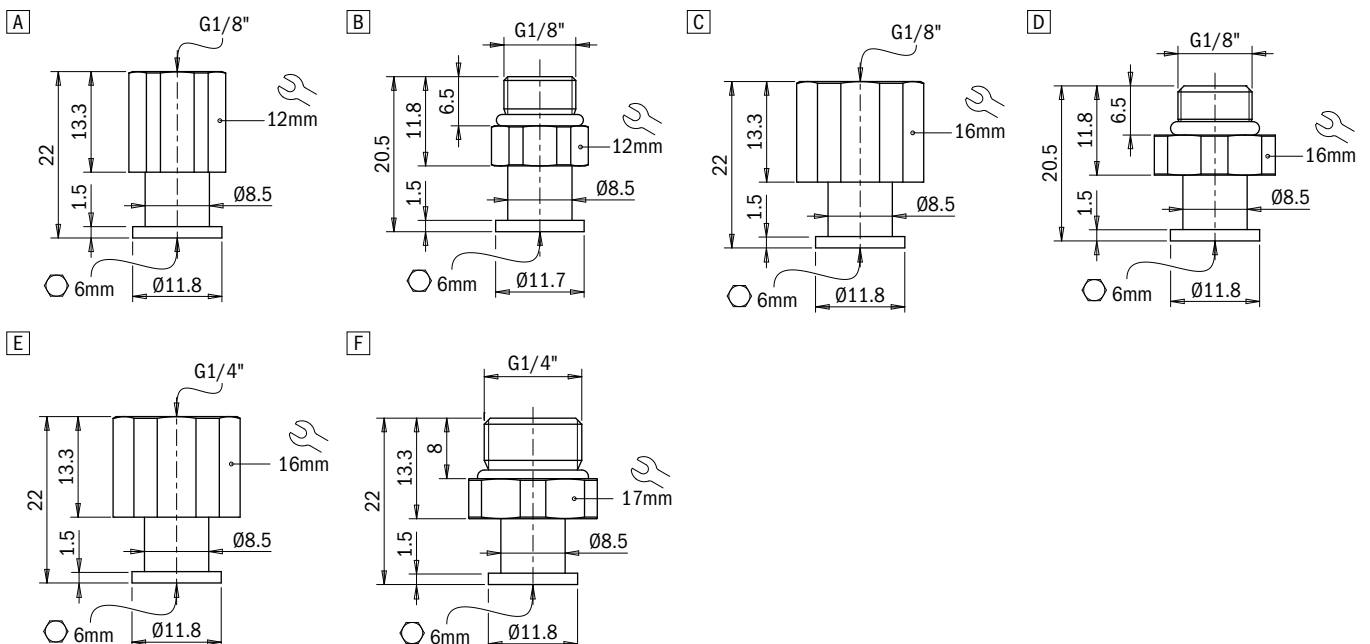

Suction cups / FDA-compliant silicone

VG.B6F bellows suction cups in FDA-compliant silicone

- Food-grade silicone compound (FDA-approved)
- Suitable for high working temperatures
- Suitable for objects with flat or slightly curved surfaces
- They enable to compensate for differences in height



Application example

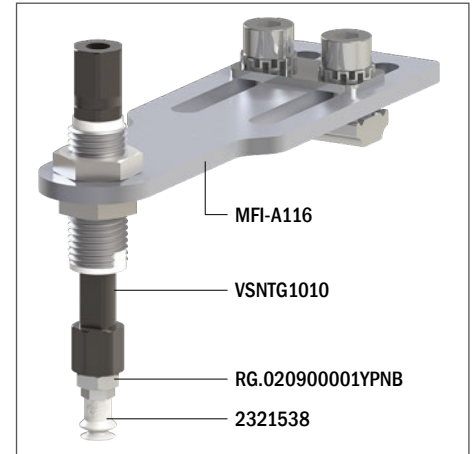

Technical data

Material	Lifting force [N] perpendicular to the surface, at various vacuum levels			Lifting force [N] parallel to the surface, at various vacuum levels			Volume [cm ³]	Min curve radius [mm]	Max vertical movement [mm]	Suction cup weight [g]
	-20 kPa	-60 kPa	-90 kPa	-20 kPa	-60 kPa	-90 kPa				
SIL 50 FDA	0.25	0.78	1.1	–	–	–	0.05	1.5	1.5	0.1

Technical features

Material	Color	Hardness	Temperature range
Silicone, FDA SIL	Transparent	50 Shore	-94 - +392 °F

Identification codes			
Drawing	Alphanumeric code	Suction cups with fitting	Order code
A	VG.B6F.50.M3M.E5	VG.B6 suction cup, FDA-compliant silicone, 50 Shore, M3 Male, 5 mm hex	2321538
B	VG.B6F.50.M5M.E8	VG.B6 suction cup, FDA-compliant silicone, 50 Shore, M5 Male, 8 mm hex	2321038

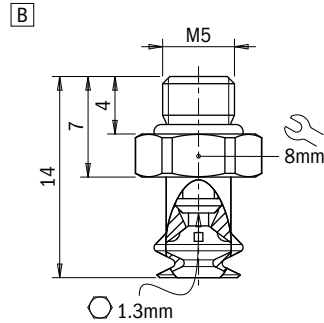
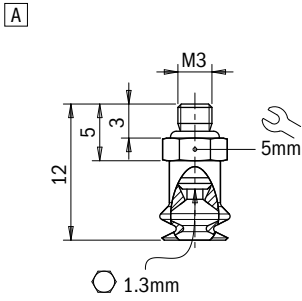

Identification codes			
Drawing	Alphanumeric code	Suction cups	Order code
A	VG.B6F.50	VG.B6 suction cup, FDA-compliant silicone, 50 Shore	2321539

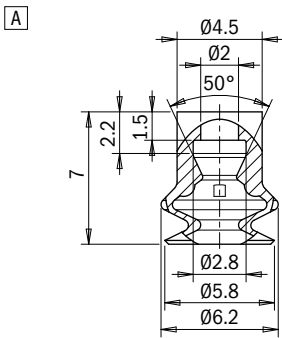

Identification codes			
Drawing	Alphanumeric code	Fittings	Order code
A	FT.M3M.E5	M3 male fitting, hex, 5 mm	2321402
B	FT.M5M.E8.06	M5 male fitting, hex, 8 mm	2321005

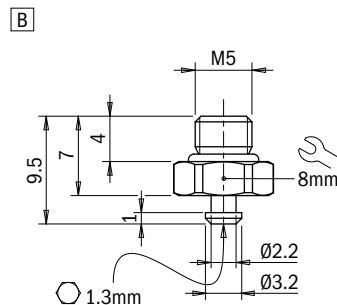
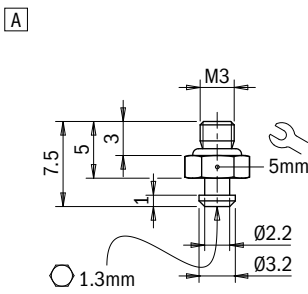

Suction cups / FDA-compliant silicone

VG.B9F bellows suction cups in FDA-compliant silicone

- Food-grade silicone compound (FDA-approved)
- Suitable for high working temperatures
- Suitable for objects with flat or slightly curved surfaces
- They enable to compensate for differences in height

Application example

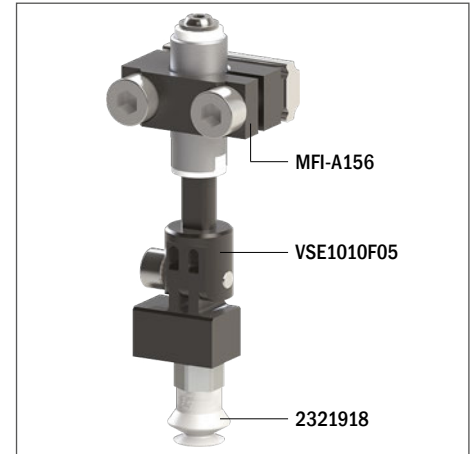

Technical data

Material	Lifting force [N] perpendicular to the surface, at various vacuum levels			Lifting force [N] parallel to the surface, at various vacuum levels			Volume [cm ³]	Min curve radius [mm]	Max vertical movement [mm]	Suction cup weight [g]
	-20 kPa	-60 kPa	-90 kPa	-20 kPa	-60 kPa	-90 kPa				
SIL 50 FDA	0.82	1.5	2.3	–	–	–	0.15	1.9	3.5	0.3

Technical features

Material	Color	Hardness	Temperature range
Silicone, FDA SIL	Transparent	50 Shore	-94 - +392 °F

Identification codes			
Drawing	Alphanumeric code	Suction cups with fitting	Order code
A	VG.B9F.50.M5M.E8	VG.B9 suction cup, FDA-compliant silicone, 50 Shore, M5 male, 8 mm hex	2321918

A

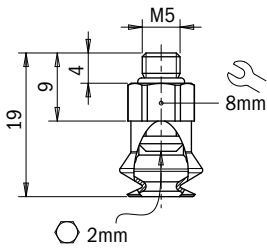

Identification codes			
Drawing	Alphanumeric code	Suction cups	Order code
A	VG.B9F.50	VG.B9 suction cup, FDA-compliant silicone, 50 Shore	2321919

A

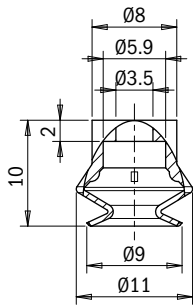

Identification codes			
Drawing	Alphanumeric code	Fittings	Order code
A	FT.M5M.E8.05	M5 male fitting, 8 mm hex	2321405

A

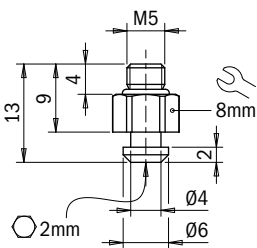

Suction cups / FDA-compliant silicone

VG.B11F bellows suction cups in FDA-compliant silicone

- Food-grade silicone compound (FDA-approved)
- Suitable for high working temperatures
- Suitable for objects with flat or slightly curved surfaces
- They enable to compensate for differences in height

Application example



Technical data

Material	Lifting force [N] perpendicular to the surface, at various vacuum levels			Lifting force [N] parallel to the surface, at various vacuum levels			Volume [cm ³]	Min curve radius [mm]	Max vertical movement [mm]	Suction cup weight [g]
	-20 kPa	-60 kPa	-90 kPa	-20 kPa	-60 kPa	-90 kPa				
SIL 50 FDA	1.3	3.4	4.6	1.7	2.42	2.81	0.48	4	4.5	1.3

Technical features

Material	Color	Hardness	Temperature range
Silicone, FDA SIL	Transparent	50 Shore	-94 - +392 °F

Identification codes			
Drawing	Alphanumeric code	Suction cups with fitting	Order code
A	VG.B11F.50.M5F.E8	VG.B11 suction cup, FDA-compliant silicone, 50 Shore, M5 female, 8 mm hex	2321540
B	VG.B11F.50.M5M.E8	VG.B11 suction cup, FDA-compliant silicone, 50 Shore, M5 male, 8 mm hex	2321542
C	VG.B11F.50.G18F.E13	VG.B11 suction cup, FDA-compliant silicone, 50 Shore, G1/8" female, 13 mm hex	2321543
D	VG.B11F.50.G18M.E13	VG.B11 suction cup, FDA-compliant silicone, 50 Shore, G1/8" male, 13 mm hex	2321544

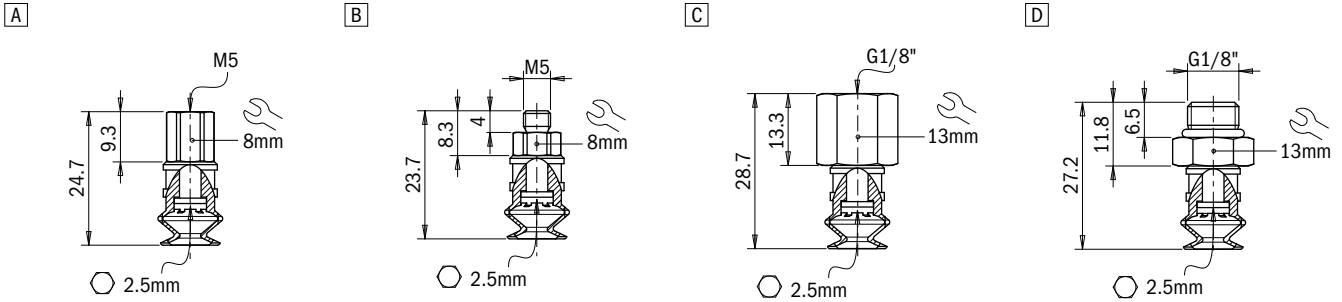

Identification codes			
Drawing	Alphanumeric code	Suction cups	Order code
A	VG.B11F.50	VG.B11 suction cup, FDA-compliant silicone, 50 Shore	2321541

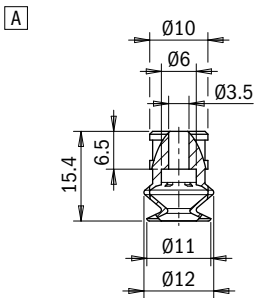

Identification codes			
Drawing	Alphanumeric code	Fittings	Order code
A	FT.M5F.E8	M5 female fitting, 8 mm hex	2321408
B	FT.M5M.E8	M5 male fitting, 8 mm hex	2321410
C	FT.G18F.E13	G1/8" female fitting, 13 mm hex	2321412
D	FT.G18M.E13	G1/8" male fitting, 13 mm hex	2321414

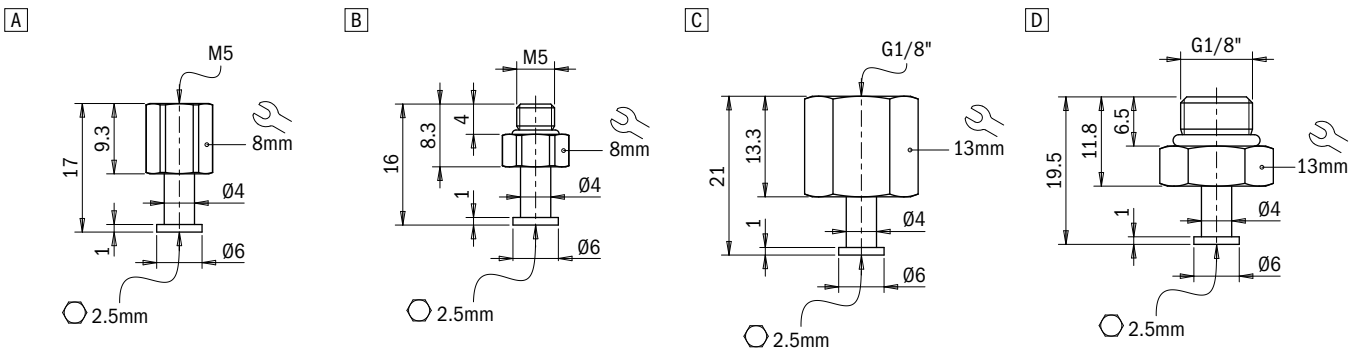

Suction cups / FDA-compliant silicone

VG.B16F bellows suction cups in FDA-compliant silicone

- Food-grade silicone compound (FDA-approved)
- Suitable for high working temperatures
- Suitable for objects with flat or slightly curved surfaces
- They enable to compensate for differences in height



Application example

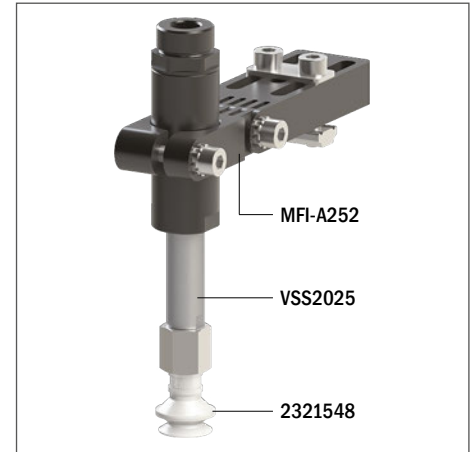

Technical data

Material	Lifting force [N] perpendicular to the surface, at various vacuum levels			Lifting force [N] parallel to the surface, at various vacuum levels			Volume [cm ³]	Min curve radius [mm]	Max vertical movement [mm]	Suction cup weight [g]
	-20 kPa	-60 kPa	-90 kPa	-20 kPa	-60 kPa	-90 kPa				
SIL 50 FDA	3	5.8	8.5	1.71	3.1	3.9	1.1	5	6.5	2.1

Technical features

Material	Color	Hardness	Temperature range
Silicone, FDA SIL	Transparent	50 Shore	-94 - +392 °F

Identification codes			
Drawing	Alphanumeric code	Suction cups with fitting	Order code
A	VG.B16F.50.M5F.E8	VG.B16 suction cup, FDA-compliant silicone, 50 Shore, M5 female, 8 mm hex	2321545
B	VG.B16F.50.M5M.E8	VG.B16 suction cup, FDA-compliant silicone, 50 Shore, M5 male, 8 mm hex	2321547
C	VG.B16F.50.G18F.E13	VG.B16 suction cup, FDA-compliant silicone, 50 Shore, G1/8" female, 13 mm hex	2321548
D	VG.B16F.50.G18M.E13	VG.B16 suction cup, FDA-compliant silicone, 50 Shore, G1/8" male, 13 mm hex	2321549

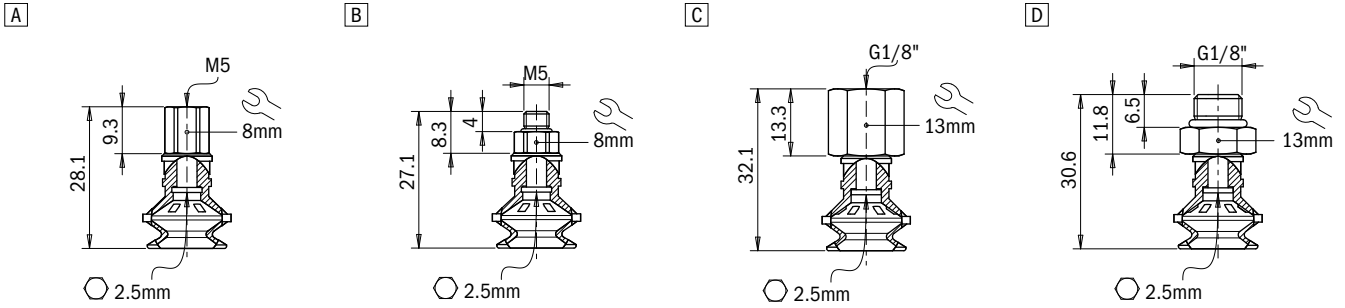

Identification codes			
Drawing	Alphanumeric code	Suction cups	Order code
A	VG.B16F.50	VG.B16 suction cup, FDA-compliant silicone, 50 Shore	2321546

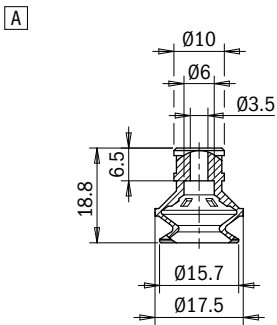

Identification codes			
Drawing	Alphanumeric code	Fittings	Order code
A	FT.M5F.E8	M5 female fitting, 8 mm hex	2321408
B	FT.M5M.E8	M5 male fitting, 8 mm hex	2321410
C	FT.G18F.E13	G1/8" female fitting, 13 mm hex	2321412
D	FT.G18M.E13	G1/8" male fitting, 13 mm hex	2321414

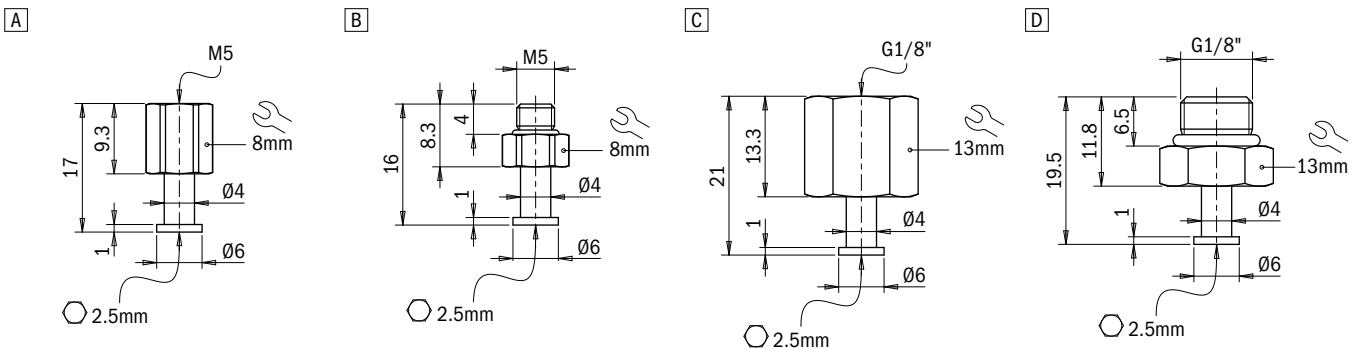

Suction cups / FDA-compliant silicone

VG.B22F bellows suction cups in FDA-compliant silicone

- Food-grade silicone compound (FDA-approved)
- Suitable for high working temperatures
- Suitable for objects with flat or slightly curved surfaces
- They enable to compensate for differences in height

Application example

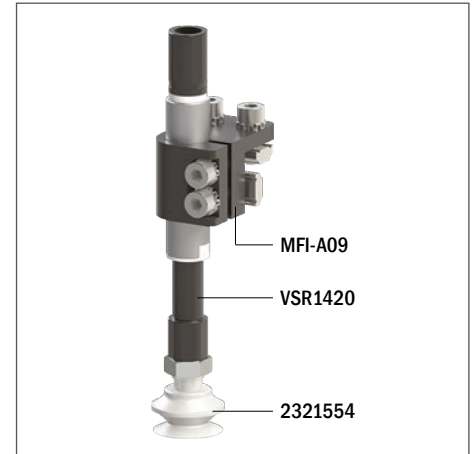

Technical data

Material	Lifting force [N] perpendicular to the surface, at various vacuum levels			Lifting force [N] parallel to the surface, at various vacuum levels			Volume [cm ³]	Min curve radius [mm]	Max vertical movement [mm]	Suction cup weight [g]
	-20 kPa	-60 kPa	-90 kPa	-20 kPa	-60 kPa	-90 kPa				
SIL 50 FDA	5.5	13	14	2.92	5.5	8.3	2.7	10	10	1.9

Technical features

Material	Color	Hardness	Temperature range
Silicone, FDA SIL	Transparent	50 Shore	-94 - +392 °F

Identification codes

Drawing	Alphanumeric code	Suction cups with fitting	Order code
A	VG.B22F.50.M5F.E8	VG.B22 suction cup, FDA-compliant silicone, 50 Shore, M5 female, 8 mm hex	2321550
B	VG.B22F.50.M5M.E8	VG.B22 suction cup, FDA-compliant silicone, 50 Shore, M5 male, 8 mm hex	2321552
C	VG.B22F.50.G18F.E13	VG.B22 suction cup, FDA-compliant silicone, 50 Shore, G1/8" female, 13 mm hex	2321553
D	VG.B22F.50.G18M.E13	VG.B22 suction cup, FDA-compliant silicone, 50 Shore, G1/8" male, 13 mm hex	2321554

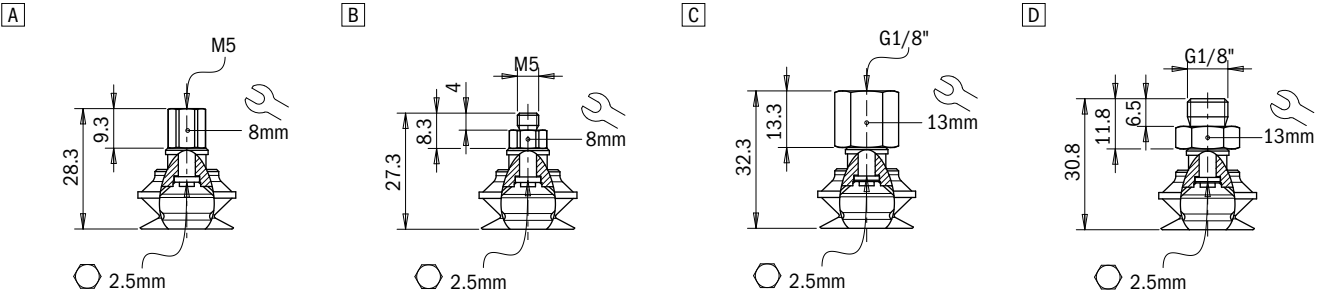

Identification codes

Drawing	Alphanumeric code	Suction cups	Order code
A	VG.B22F.50	VG.B22 suction cup, FDA-compliant silicone, 50 Shore	2321551

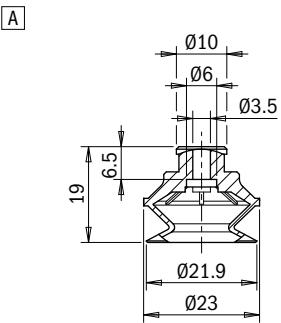

Identification codes

Drawing	Alphanumeric code	Fittings	Order code
A	FT.M5F.E8	M5 female fitting, 8 mm hex	2321408
B	FT.M5M.E8	M5 male fitting, 8 mm hex	2321410
C	FT.G18F.E13	G1/8" female fitting, 13 mm hex	2321412
D	FT.G18M.E13	G1/8" male fitting, 13 mm hex	2321414

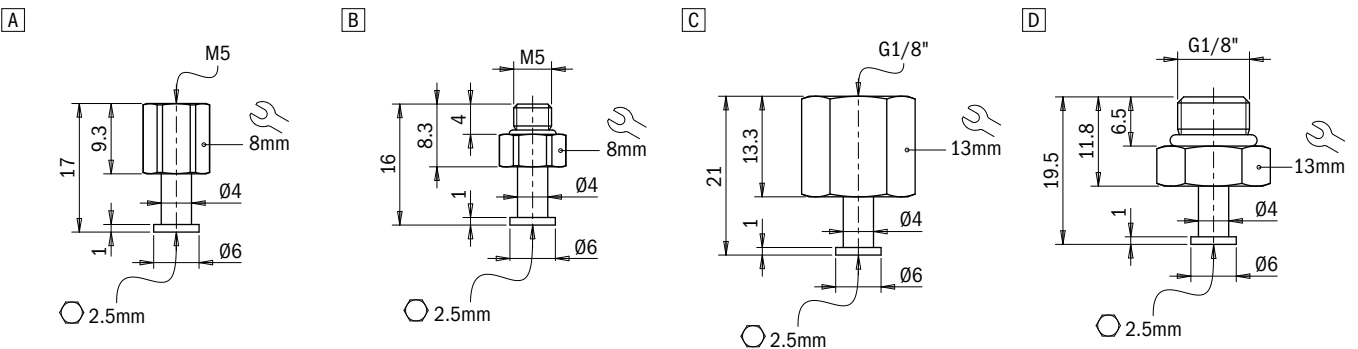

Suction cups / FDA-compliant silicone

VG.B33F bellows suction cups in FDA-compliant silicone

- Food-grade silicone compound (FDA-approved)
- Suitable for high working temperatures
- Suitable for objects with flat or slightly curved surfaces
- They enable to compensate for differences in height

Application example

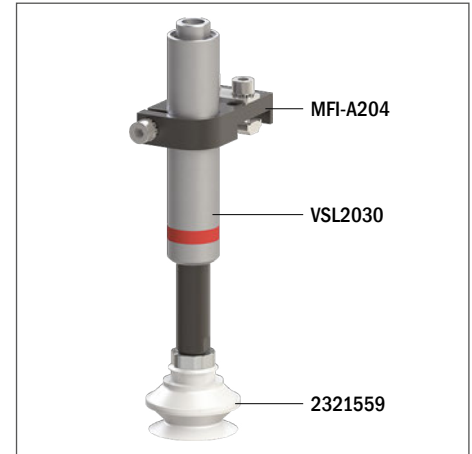

Technical data

Material	Lifting force [N] perpendicular to the surface, at various vacuum levels			Lifting force [N] parallel to the surface, at various vacuum levels			Volume [cm ³]	Min curve radius [mm]	Max vertical movement [mm]	Suction cup weight [g]
	-20 kPa	-60 kPa	-90 kPa	-20 kPa	-60 kPa	-90 kPa				
SIL 50 FDA	12	23	26	9.5	16.6	22.5	10	15	15	5.9

Technical features

Material	Color	Hardness	Temperature range
Silicone, FDA SIL	Transparent	50 Shore	-94 - +392 °F

Identification codes

Drawing	Alphanumeric code	Suction cups with fitting	Order code
A	VG.B33F.50.G18F.E12	VG.B33 suction cup, FDA-compliant silicone, 50 Shore, G1/8" female, 12 mm hex	2321555
B	VG.B33F.50.G18M.E12	VG.B33 suction cup, FDA-compliant silicone, 50 Shore, G1/8" male, 12 mm hex	2321557
C	VG.B33F.50.G18F.E16	VG.B33 suction cup, FDA-compliant silicone, 50 Shore, G1/8" female, 16 mm hex	2321558
D	VG.B33F.50.G18M.E16	VG.B33 suction cup, FDA-compliant silicone, 50 Shore, G1/8" male, 16 mm hex	2321559
E	VG.B33F.50.G14F.E16	VG.B33 suction cup, FDA-compliant silicone, 50 Shore, G1/4" female, 16 mm hex	2321560
F	VG.B33F.50.G14M.E17	VG.B33 suction cup, FDA-compliant silicone, 50 Shore, G1/4" male, 17 mm hex	2321561

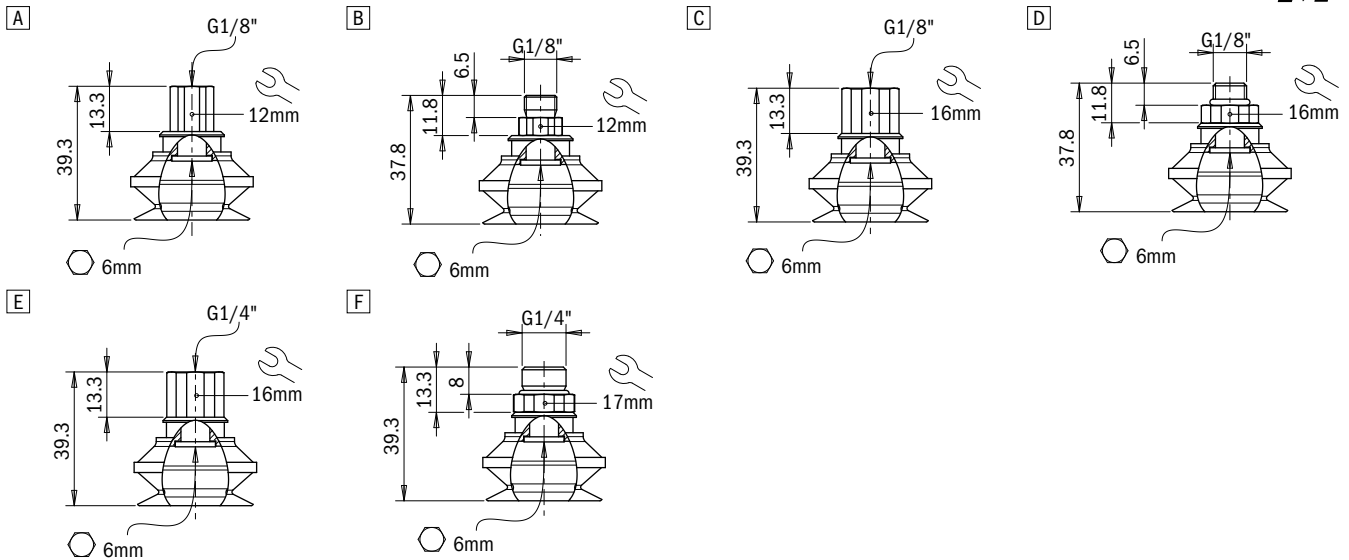

Identification codes

Drawing	Alphanumeric code	Suction cups	Order code
A	VG.B33F.50	VG.B33 suction cup, FDA-compliant silicone, 50 Shore	2321556



Click for Pricing & Add to Cart

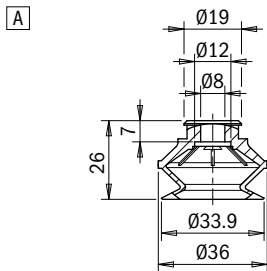

Identification codes

Drawing	Alphanumeric code	Fittings	Order code
A	FT.G18F.E12	G1/8" female fitting, 12 mm hex	2321422
B	FT.G18M.E12	G1/8" male fitting, 12 mm hex	2321424
C	FT.G18F.E16	G1/8" female fitting, 16 mm hex	2321426
D	FT.G18M.E16	G1/8" male fitting, 16 mm hex	2321428
E	FT.G14F.E16	G1/4" female fitting, 16 mm hex	2321430
F	FT.G14M.E17	G1/4" male fitting, 17 mm hex	2321432

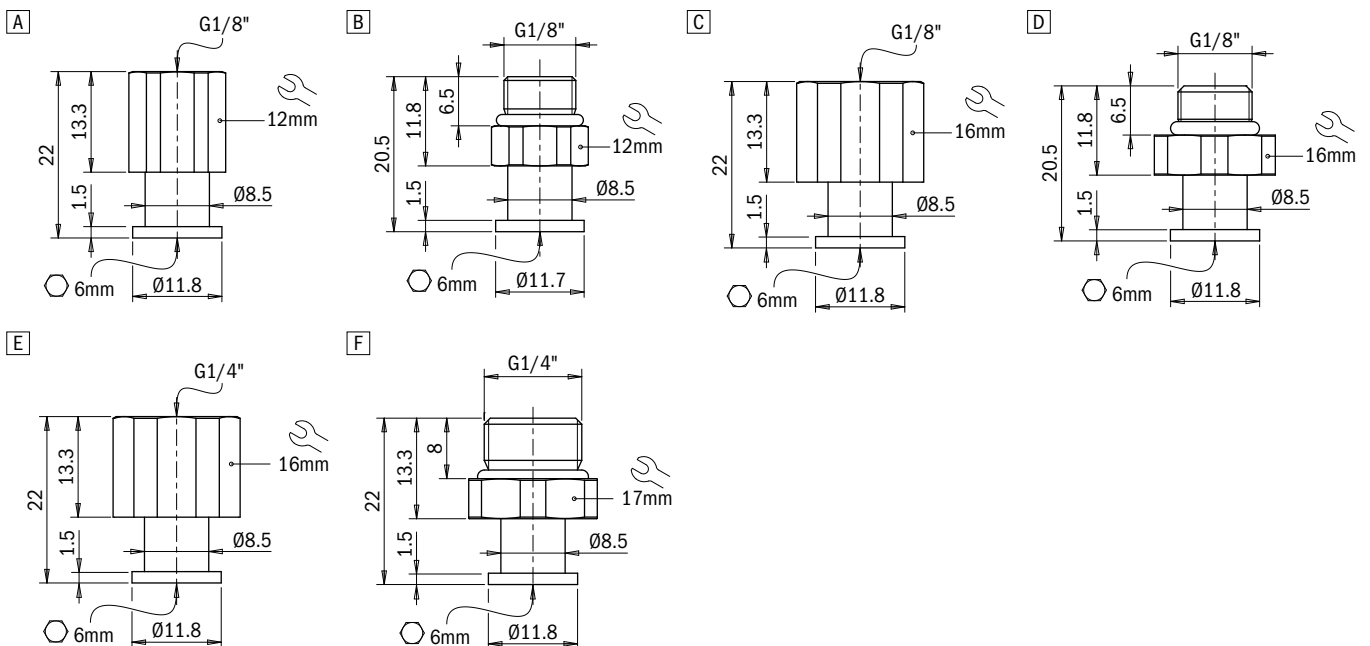

Suction cups / FDA-compliant silicone

VG.B42F bellows suction cups in FDA-compliant silicone

- Food-grade silicone compound (FDA-approved)
- Suitable for high working temperatures
- Suitable for objects with flat or slightly curved surfaces
- They enable to compensate for differences in height

Application example

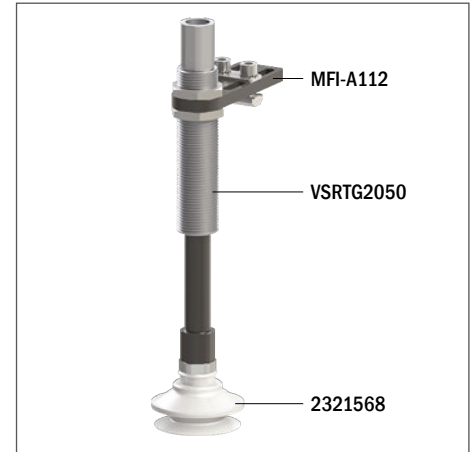

Technical data

Material	Lifting force [N] perpendicular to the surface, at various vacuum levels			Lifting force [N] parallel to the surface, at various vacuum levels			Volume [cm ³]	Min curve radius [mm]	Max vertical movement [mm]	Suction cup weight [g]
	-20 kPa	-60 kPa	-90 kPa	-20 kPa	-60 kPa	-90 kPa				
SIL 50 FDA	20	46	53	17.2	26.3	30.7	15	20	12	8.8

Technical features

Material	Color	Hardness	Temperature range
Silicone, FDA SIL	Transparent	50 Shore	-94 - +392 °F

Identification codes

Drawing	Alphanumeric code	Suction cups with fitting	Order code
A	VG.B42F.50.G18F.E12	VG.B42 suction cup, FDA-compliant silicone, 50 Shore, G1/8" female, 12 mm hex	2321562
B	VG.B42F.50.G18M.E12	VG.B42 suction cup, FDA-compliant silicone, 50 Shore, G1/8" male, 12 mm hex	2321564
C	VG.B42F.50.G18F.E16	VG.B42 suction cup, FDA-compliant silicone, 50 Shore, G1/8" female, 16 mm hex	2321565
D	VG.B42F.50.G18M.E16	VG.B42 suction cup, FDA-compliant silicone, 50 Shore, G1/8" male, 16 mm hex	2321566
E	VG.B42F.50.G14F.E16	VG.B42 suction cup, FDA-compliant silicone, 50 Shore, G1/4" female, 16 mm hex	2321567
F	VG.B42F.50.G14M.E17	VG.B42 suction cup, FDA-compliant silicone, 50 Shore, G1/4" male, 17 mm hex	2321568

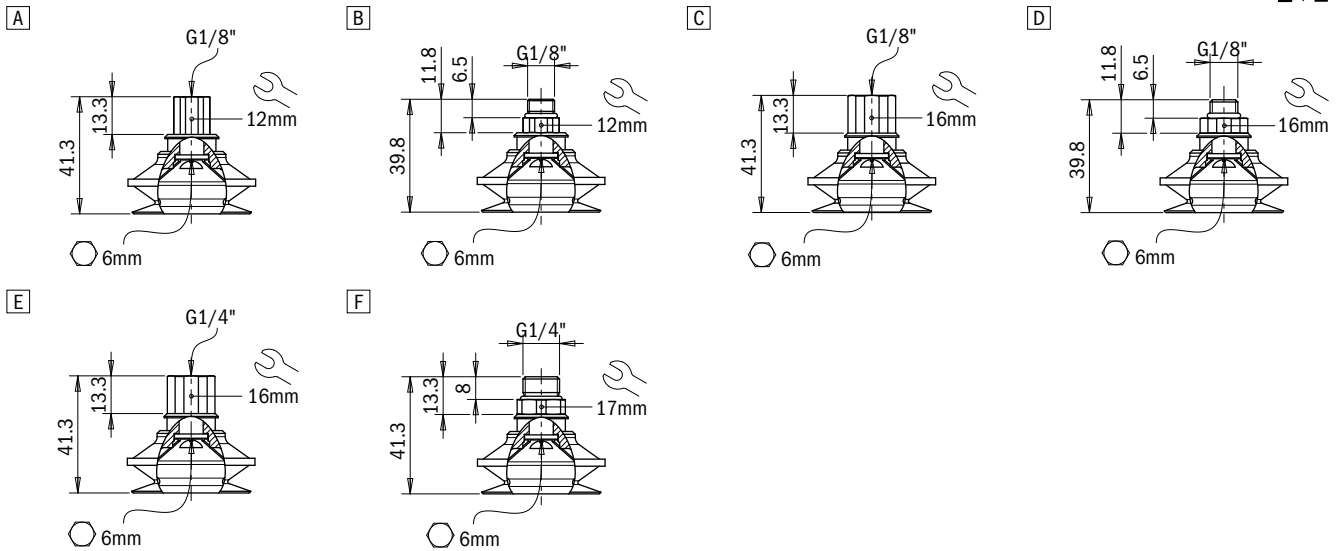

Identification codes

Drawing	Alphanumeric code	Suction cups	Order code
A	VG.B42F.50	VG.B42 suction cup, FDA-compliant silicone, 50 Shore	2321563

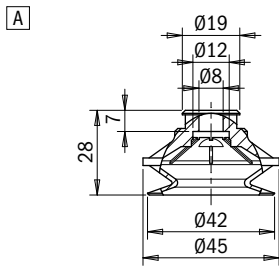

Identification codes

Drawing	Alphanumeric code	Fittings	Order code
A	FT.G18F.E12	G1/8" female fitting, 12 mm hex	2321422
B	FT.G18M.E12	G1/8" male fitting, 12 mm hex	2321424
C	FT.G18F.E16	G1/8" female fitting, 16 mm hex	2321426
D	FT.G18M.E16	G1/8" male fitting, 16 mm hex	2321428
E	FT.G14F.E16	G1/4" female fitting, 16 mm hex	2321430
F	FT.G14M.E17	G1/4" male fitting, 17 mm hex	2321432

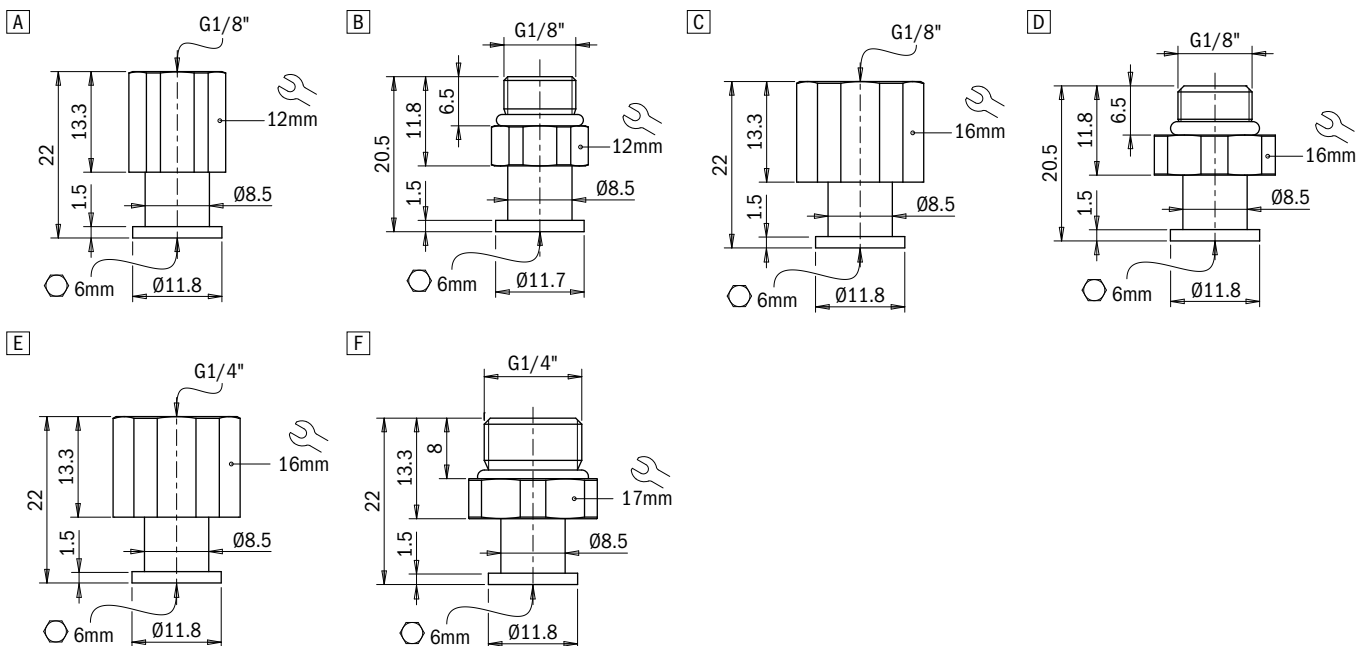

Suction cups / FDA-compliant silicone

VG.B53F bellows suction cups in FDA-compliant silicone

- Food-grade silicone compound (FDA-approved)
- Suitable for high working temperatures
- Suitable for objects with flat or slightly curved surfaces
- They enable to compensate for differences in height



Application example

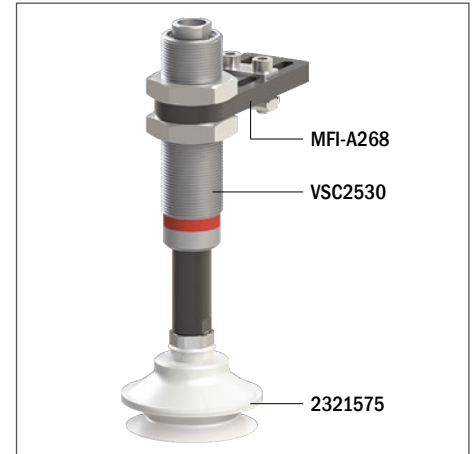

Technical data

Material	Lifting force [N] perpendicular to the surface, at various vacuum levels			Lifting force [N] parallel to the surface, at various vacuum levels			Volume [cm ³]	Min curve radius [mm]	Max vertical movement [mm]	Suction cup weight [g]
	-20 kPa	-60 kPa	-90 kPa	-20 kPa	-60 kPa	-90 kPa				
SIL 50 FDA	32	64.5	90	24.5	51.3	60.5	32	30	19	15.7

Technical features

Material	Color	Hardness	Temperature range
Silicone, FDA SIL	Transparent	50 Shore	-94 - +392 °F

Identification codes

Drawing	Alphanumeric code	Suction cups with fitting	Order code
A	VG.B53F.50.G18F.E12	VG.B53 suction cup, FDA-compliant silicone, 50 Shore, G1/8" female, 12 mm hex	2321569
B	VG.B53F.50.G18M.E12	VG.B53 suction cup, FDA-compliant silicone, 50 Shore, G1/8" male, 12 mm hex	2321571
C	VG.B53F.50.G18F.E16	VG.B53 suction cup, FDA-compliant silicone, 50 Shore, G1/8" female, 16 mm hex	2321572
D	VG.B53F.50.G18M.E16	VG.B53 suction cup, FDA-compliant silicone, 50 Shore, G1/8" male, 16 mm hex	2321573
E	VG.B53F.50.G14F.E16	VG.B53 suction cup, FDA-compliant silicone, 50 Shore, G1/4" female, 16 mm hex	2321574
F	VG.B53F.50.G14M.E17	VG.B53 suction cup, FDA-compliant silicone, 50 Shore, G1/4" male, 17 mm hex	2321575

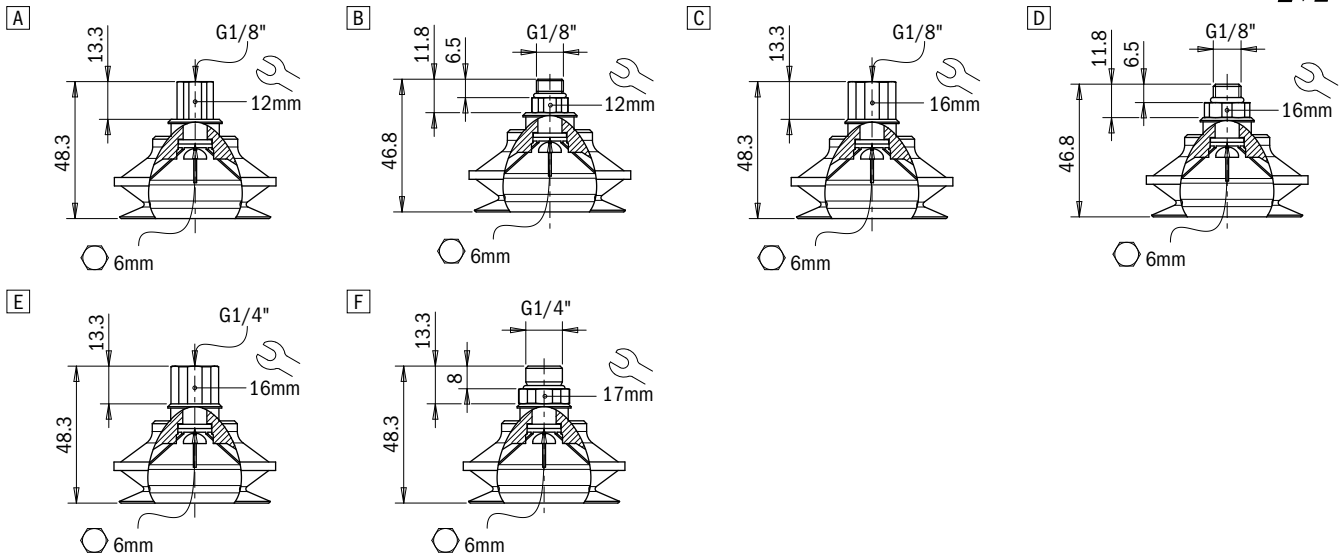

Identification codes

Drawing	Alphanumeric code	Suction cups	Order code
A	VG.B53F.50	VG.B53 suction cup, FDA-compliant silicone, 50 Shore	2321570

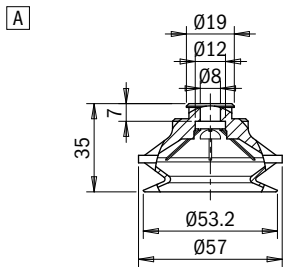

Identification codes

Drawing	Alphanumeric code	Fittings	Order code
A	FT.G18F.E12	G1/8" female fitting, 12 mm hex	2321422
B	FT.G18M.E12	G1/8" male fitting, 12 mm hex	2321424
C	FT.G18F.E16	G1/8" female fitting, 16 mm hex	2321426
D	FT.G18M.E16	G1/8" male fitting, 16 mm hex	2321428
E	FT.G14F.E16	G1/4" female fitting, 16 mm hex	2321430
F	FT.G14M.E17	G1/4" male fitting, 17 mm hex	2321432

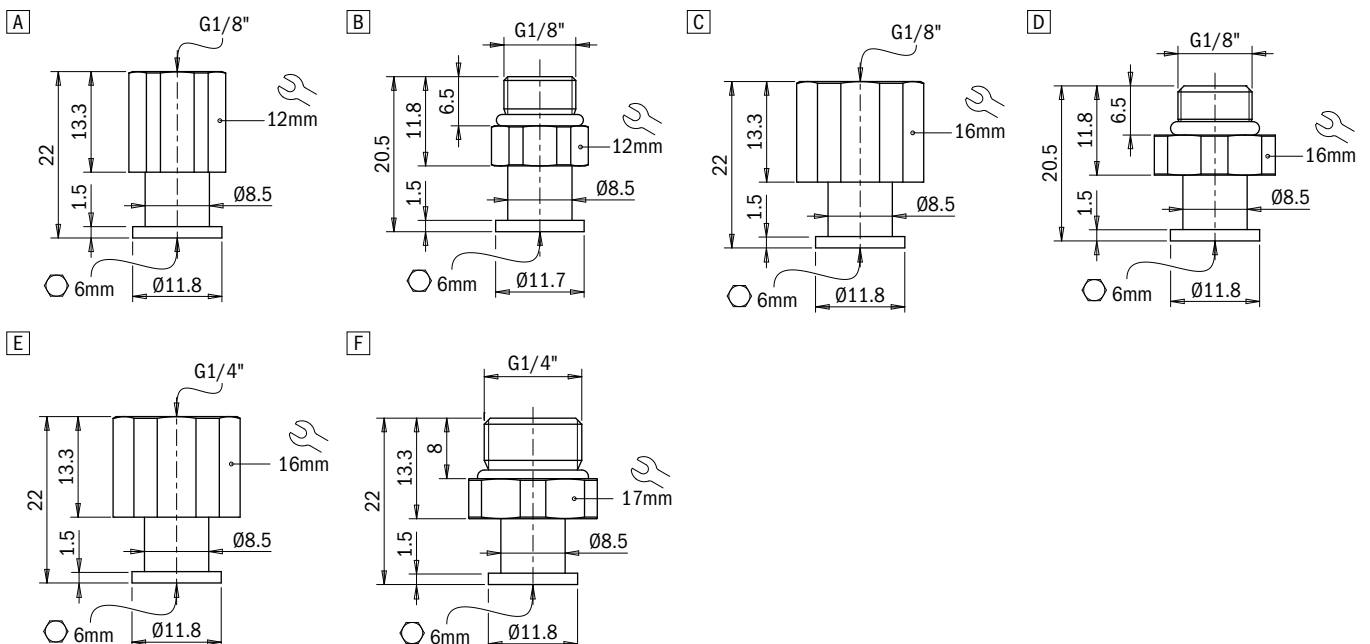

Suction cups / FDA-compliant silicone with ring in silicone foam

VG.B16F.SFO bellows suction cups in FDA-compliant silicone with silicone foam ring

- Ideal to handle uneven and porous surfaces
- High adaptability on rough wood panels, corrugated sheet metal and non-slip sheet metal
- Ring in mark-free silicone foam



Application example

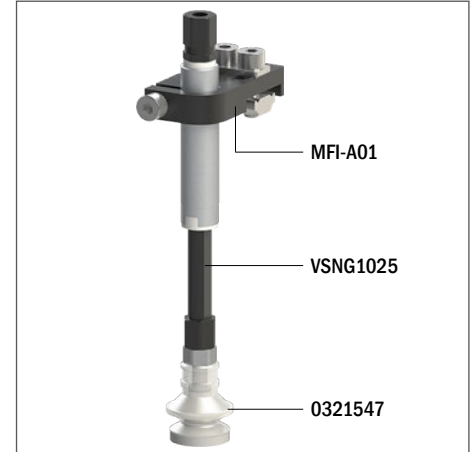

Technical features

Material	Color	Temperature range
Silicone, FDA SIL	Transparent	-67 - +392 °F

Identification codes

Drawing	Alphanumeric code	Suction cups with fitting	Order code
A	VG.B16F.50.M5F.E8.SFO	VG.B16 suction cup, FDA-compliant silicone, 50 Shore, M5 female, 8 mm hex with silicone foam ring	0321545
B	VG.B16F.50.M5M.E8.SFO	VG.B16 suction cup, FDA-compliant silicone, 50 Shore, M5 male, 8 mm hex with silicone foam ring	0321547
C	VG.B16F.50.G18F.E13.SFO	VG.B16 suction cup, FDA-compliant silicone, 50 Shore, G1/8" female, 13 mm hex with silicone foam ring	0321548
D	VG.B16F.50.G18M.E13.SFO	VG.B16 suction cup, FDA-compliant silicone, 50 Shore, G1/8" male, 13 mm hex with silicone foam ring	0321549

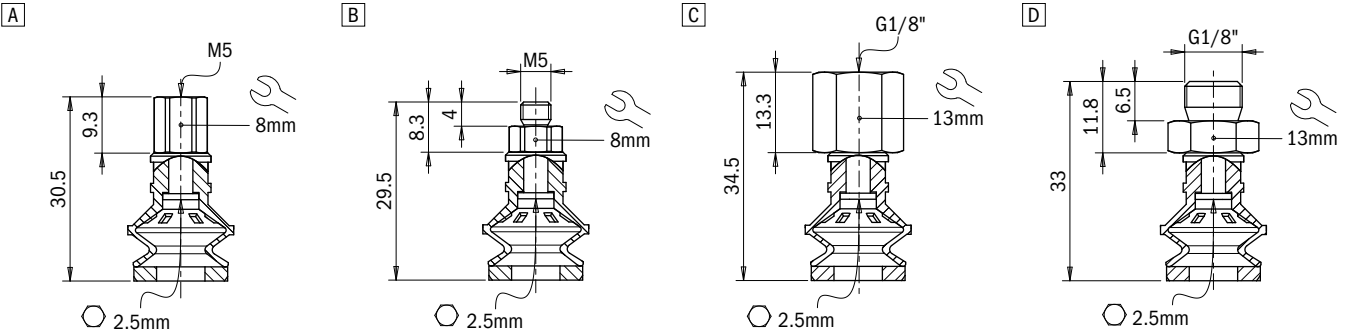

Identification codes

Drawing	Alphanumeric code	Suction cups	Order code
A	VG.B16F.SFO	VG.B16 suction cup in FDA-compliant silicone, 50 Shore, with silicone foam ring	0321546

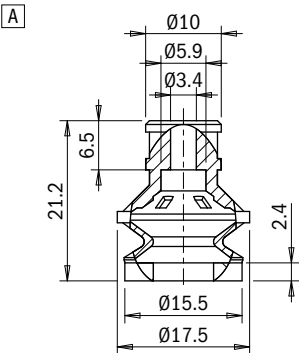

Identification codes

Drawing	Alphanumeric code	Fittings	Order code
A	FT.M5F.E8	M5 female fitting, 8 mm hex	2321408
B	FT.M5M.E8	M5 male fitting, 8 mm hex	2321410
C	FT.G18F.E13	G1/8" female fitting, 13 mm hex	2321412
D	FT.G18M.E13	G1/8" male fitting, 13 mm hex	2321414

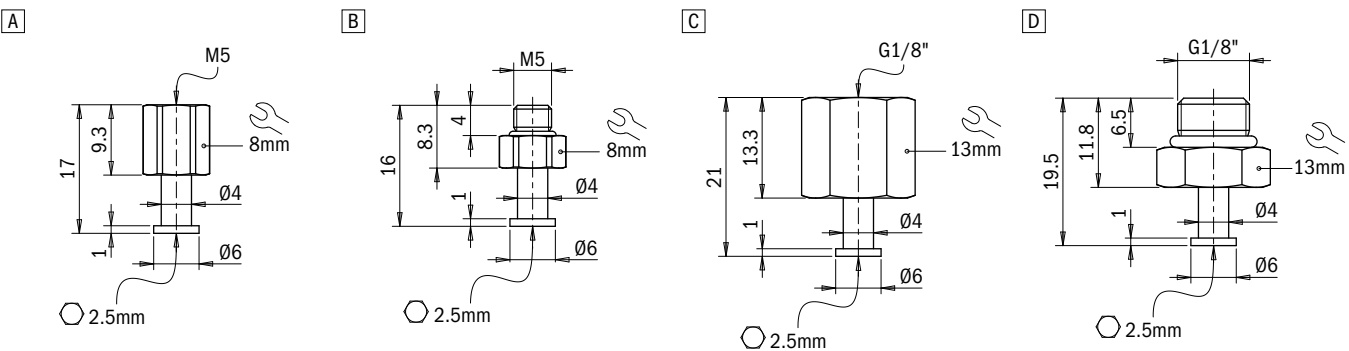

Suction cups / FDA-compliant silicone with ring in silicone foam

VG.B22F.SFO bellows suction cups in FDA-compliant silicone with silicone foam ring

- Ideal to handle uneven and porous surfaces
- High adaptability on rough wood panels, corrugated sheet metal and non-slip sheet metal
- Ring in mark-free silicone foam

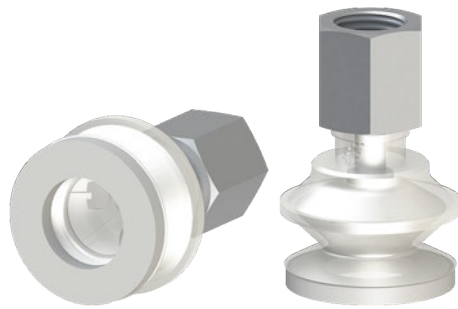

Application example

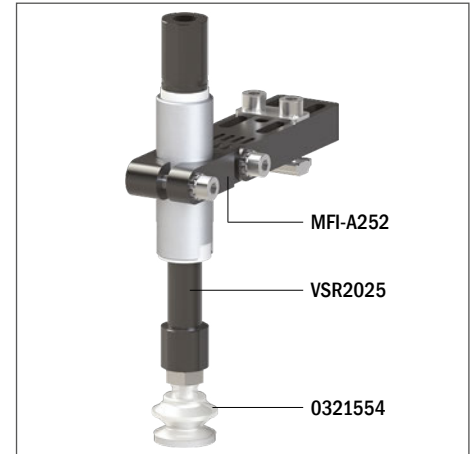

Technical features

Material	Color	Temperature range
Silicone, FDA SIL	Transparent	-67 - +392 °F

Identification codes

Drawing	Alphanumeric code	Suction cups with fitting	Order code
A	VG.B22F.50.M5F.E8.SFO	VG.B22 suction cup, FDA-compliant silicone, 50 Shore, M5 female, 8 mm hex with silicone foam ring	0321550
B	VG.B22F.50.M5M.E8.SFO	VG.B22 suction cup, FDA-compliant silicone, 50 Shore, M5 male, 8 mm hex with silicone foam ring	0321552
C	VG.B22F.50.G18F.E13.SFO	VG.B22 suction cup, FDA-compliant silicone, 50 Shore, G1/8" female, 13 mm hex with silicone foam ring	0321553
D	VG.B22F.50.G18M.E13.SFO	VG.B22 suction cup, FDA-compliant silicone, 50 Shore, G1/8" male, 13 mm hex with silicone foam ring	0321554

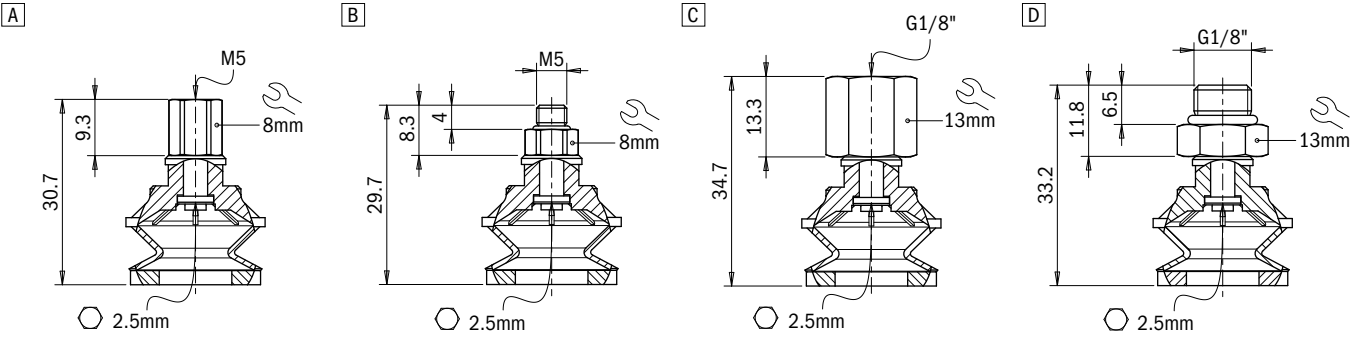

Identification codes

Drawing	Alphanumeric code	Suction cups	Order code
A	VG.B22F.SFO	VG.B22 suction cup in FDA-compliant silicone, 50 Shore, with silicone foam ring	0321551

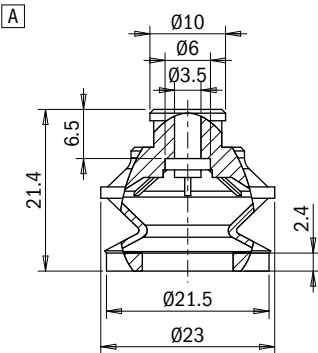

Identification codes

Drawing	Alphanumeric code	Fittings	Order code
A	FT.M5F.E8	M5 female fitting, 8 mm hex	2321408
B	FT.M5M.E8	M5 male fitting, 8 mm hex	2321410
C	FT.G18F.E13	G1/8" female fitting, 13 mm hex	2321412
D	FT.G18M.E13	G1/8" male fitting, 13 mm hex	2321414

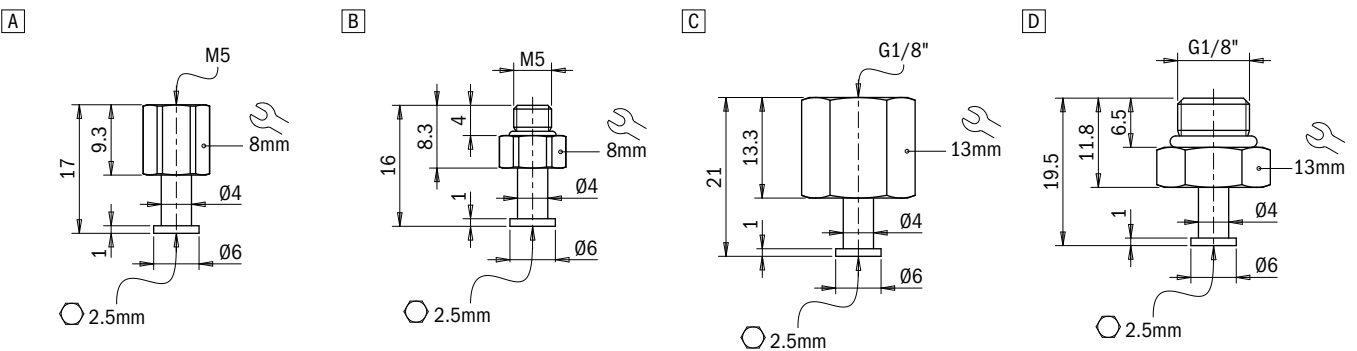

Suction cups / FDA-compliant silicone with ring in silicone foam

VG.B33F.SFO bellows suction cups in FDA-compliant silicone with silicone foam ring

- Ideal to handle uneven and porous surfaces
- High adaptability on rough wood panels, corrugated sheet metal and non-slip sheet metal
- Ring in mark-free silicone foam



Application example

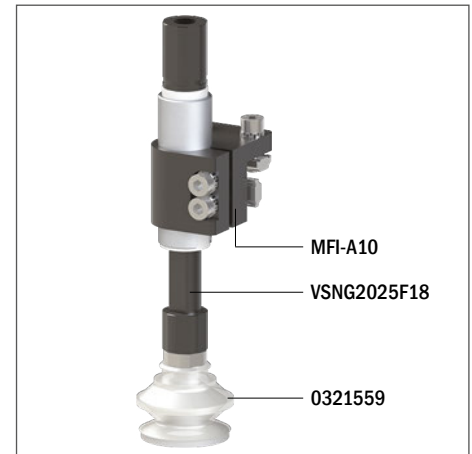

Technical features

Material	Color	Temperature range
Silicone, FDA SIL	Transparent	-67 - +392 °F

Identification codes

Drawing	Alphanumeric code	Suction cups with fitting	Order code
A	VG.B33F.50.G18F.E12.SFO	VG.B33 suction cup, FDA-compliant silicone, 50 Shore, G1/8" female, 12 mm hex with silicone foam ring	0321555
B	VG.B33F.50.G18M.E12.SFO	VG.B33 suction cup, FDA-compliant silicone, 50 Shore, G1/8" male, 12 mm hex with silicone foam ring	0321557
C	VG.B33F.50.G18F.E16.SFO	VG.B33 suction cup, FDA-compliant silicone, 50 Shore, G1/8" female, 16 mm hex with silicone foam ring	0321558
D	VG.B33F.50.G18M.E16.SFO	VG.B22 suction cup, FDA-compliant silicone, 50 Shore, G1/8" male, 16 mm hex with silicone foam ring	0321559
E	VG.B33F.50.G14F.E16.SFO	VG.B33 suction cup, FDA-compliant silicone, 50 Shore, G1/4" female, 16 mm hex with silicone foam ring	0321560
F	VG.B33F.50.G14M.E17.SFO	VG.B33 suction cup, FDA-compliant silicone, 50 Shore, G1/4" male, 17 mm hex with silicone foam ring	0321561

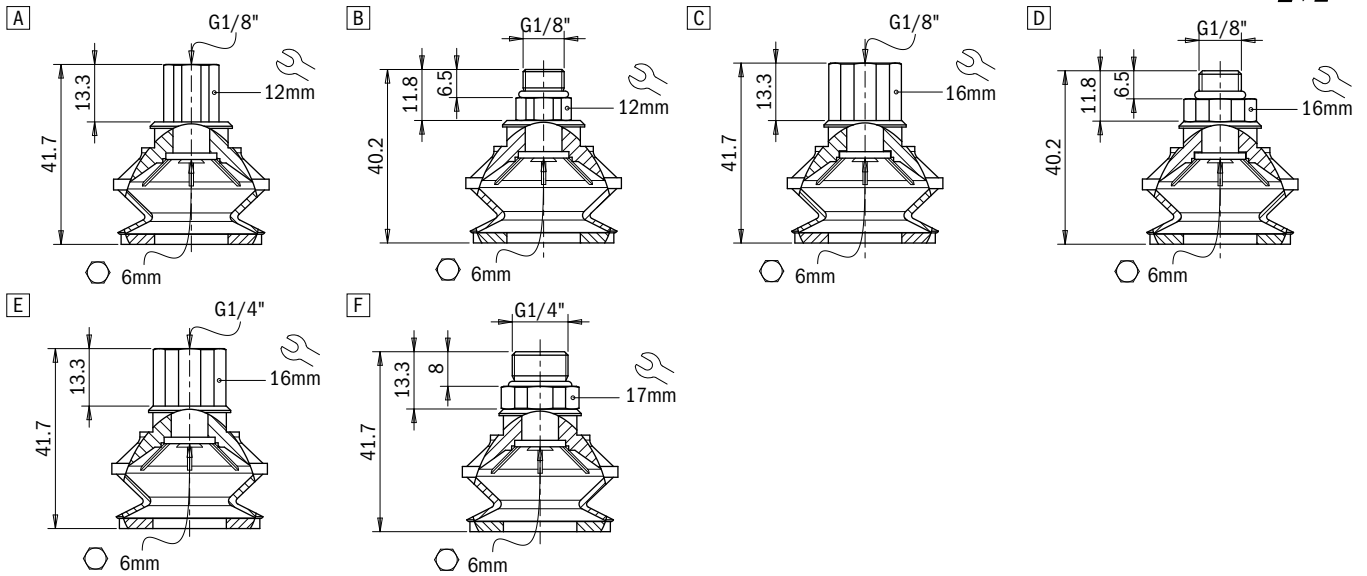

Identification codes

Drawing	Alphanumeric code	Suction cups	Order code
A	VG.B33F.SFO	VG.B33 suction cup in FDA-compliant silicone, 50 Shore, with silicone foam ring	0321556

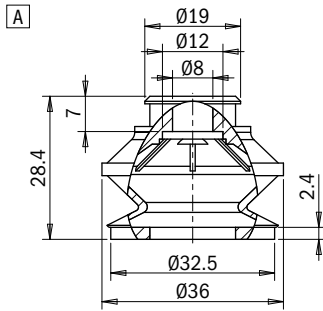

Identification codes

Drawing	Alphanumeric code	Fittings	Order code
A	FT.G18F.E12	G1/8" female fitting, 12 mm hex	2321422
B	FT.G18M.E12	G1/8" male fitting, 12 mm hex	2321424
C	FT.G18F.E16	G1/8" female fitting, 16 mm hex	2321426
D	FT.G18M.E16	G1/8" male fitting, 16 mm hex	2321428
E	FT.G14F.E16	G1/4" female fitting, 16 mm hex	2321430
F	FT.G14M.E17	G1/4" male fitting, 17 mm hex	2321432

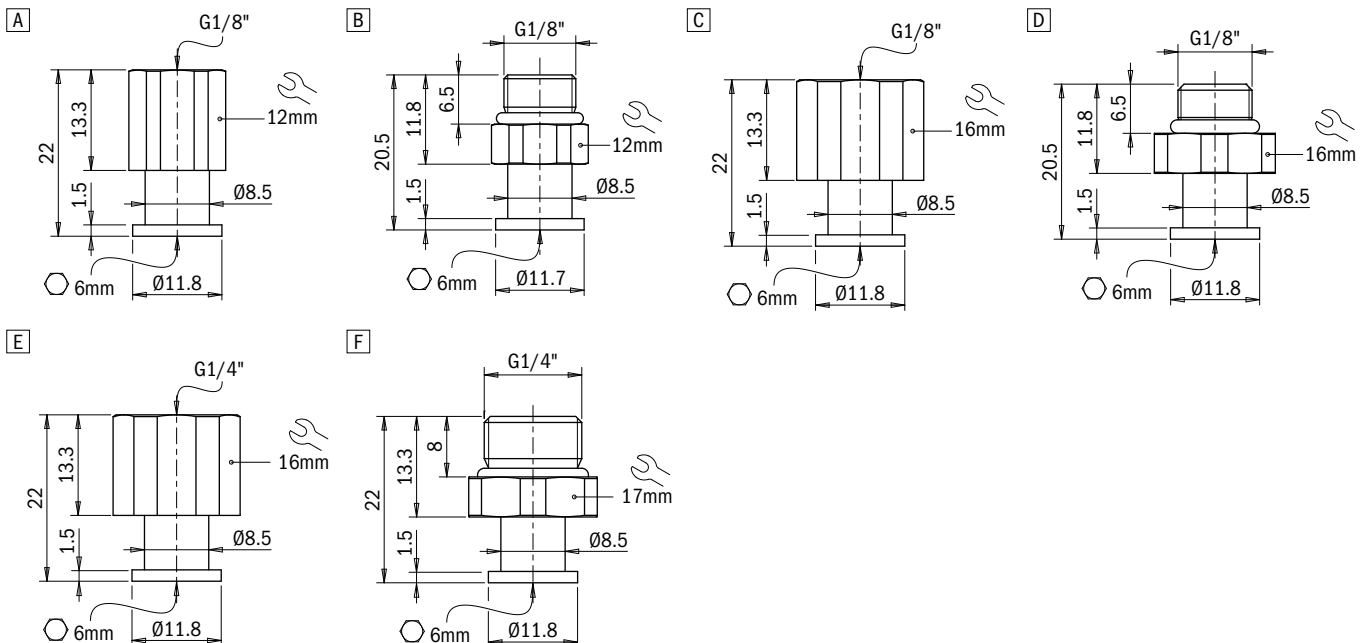

Suction cups / FDA-compliant silicone with ring in silicone foam

VG.B42F.SFO bellows suction cups in FDA-compliant silicone with silicone foam ring

- Ideal to handle uneven and porous surfaces
- High adaptability on rough wood panels, corrugated sheet metal and non-slip sheet metal
- Ring in mark-free silicone foam



Application example

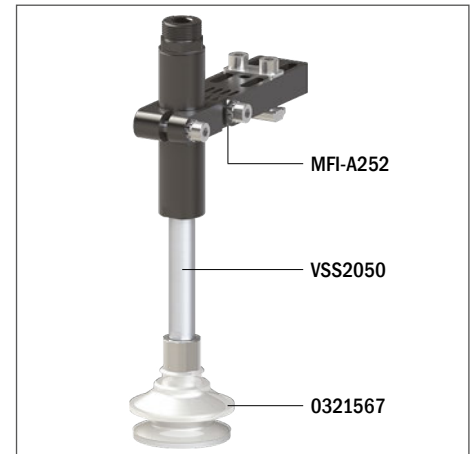

Technical features

Material	Color	Temperature range
Silicone, FDA SIL	Transparent	-67 - +392 °F

Identification codes

Drawing	Alphanumeric code	Suction cups with fitting	Order code
A	VG.B42F.50.G18F.E12.SFO	VG.B42 suction cup, FDA-compliant silicone, 50 Shore, G1/8" female, 12 mm hex with silicone foam ring	0321562
B	VG.B42F.50.G18M.E12.SFO	VG.B42 suction cup, FDA-compliant silicone, 50 Shore, G1/8" male, 12 mm hex with silicone foam ring	0321564
C	VG.B42F.50.G18F.E16.SFO	VG.B42 suction cup, FDA-compliant silicone, 50 Shore, G1/8" female, 16 mm hex with silicone foam ring	0321565
D	VG.B42F.50.G18M.E16.SFO	VG.B42 suction cup, FDA-compliant silicone, 50 Shore, G1/8" male, 16 mm hex with silicone foam ring	0321566
E	VG.B42F.50.G14F.E16.SFO	VG.B42 suction cup, FDA-compliant silicone, 50 Shore, G1/4" female, 16 mm hex with silicone foam ring	0321567
F	VG.B42F.50.G14M.E17.SFO	VG.B42 suction cup, FDA-compliant silicone, 50 Shore, G1/4" male, 17 mm hex with silicone foam ring	0321568

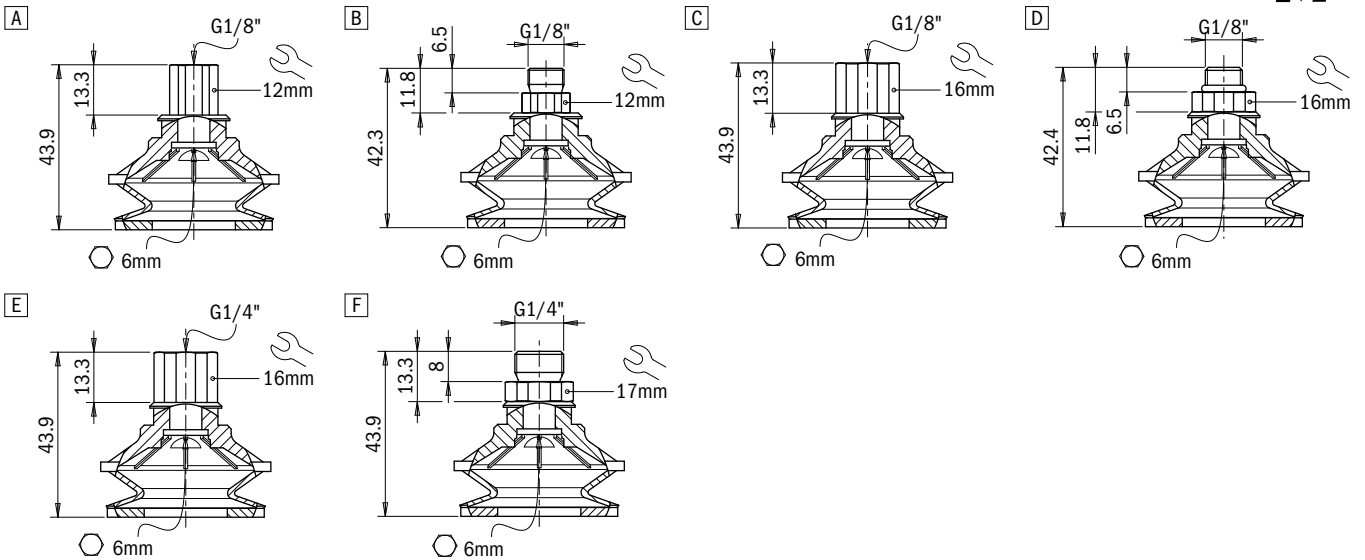

Identification codes

Drawing	Alphanumeric code	Suction cups	Order code
A	VG.B42F.SFO	VG.B42 suction cup in FDA-compliant silicone, 50 Shore, with silicone foam ring	0321563

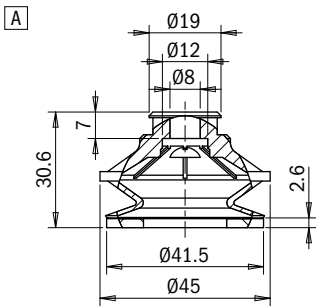

Identification codes

Drawing	Alphanumeric code	Fittings	Order code
A	FT.G18F.E12	G1/8" female fitting, 12 mm hex	2321422
B	FT.G18M.E12	G1/8" male fitting, 12 mm hex	2321424
C	FT.G18F.E16	G1/8" female fitting, 16 mm hex	2321426
D	FT.G18M.E16	G1/8" male fitting, 16 mm hex	2321428
E	FT.G14F.E16	G1/4" female fitting, 16 mm hex	2321430
F	FT.G14M.E17	G1/4" male fitting, 17 mm hex	2321432

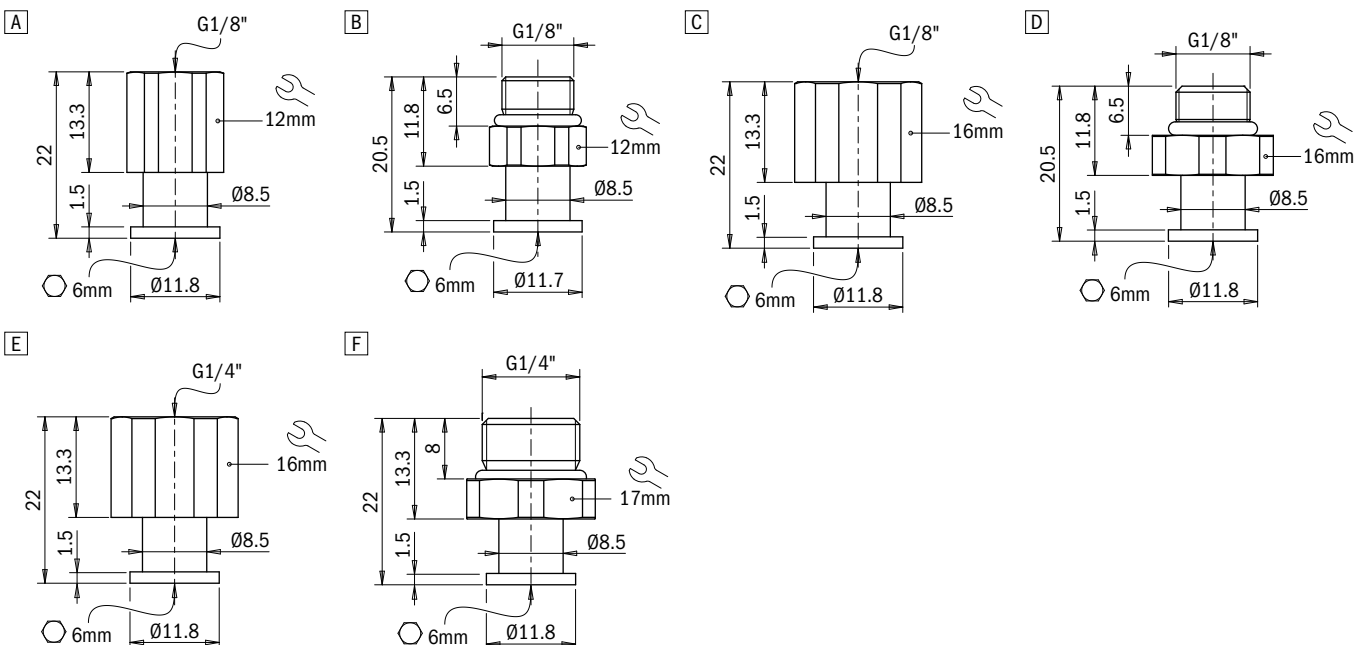

Suction cups / FDA-compliant silicone with ring in silicone foam

VG.B53F.SFO bellows suction cups in FDA-compliant silicone with silicone foam ring

- Ideal to handle uneven and porous surfaces
- High adaptability on rough wood panels, corrugated sheet metal and non-slip sheet metal
- Ring in mark-free silicone foam



Application example

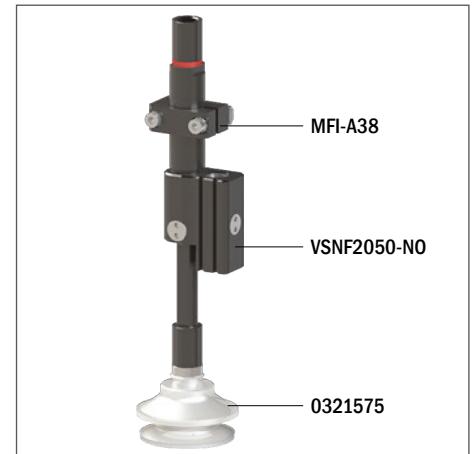

Technical features

Material	Color	Temperature range
Silicone, FDA SIL	Transparent	-67 - +392 °F

Identification codes

Drawing	Alphanumeric code	Suction cups with fitting	Order code
A	VG.B53F.50.G18F.E12.SFO	VG.B53 suction cup, FDA-compliant silicone, 50 Shore, G1/8" female, 12 mm hex with silicone foam ring	0321569
B	VG.B53F.50.G18M.E12.SFO	VG.B53 suction cup, FDA-compliant silicone, 50 Shore, G1/8" male, 12 mm hex with silicone foam ring	0321571
C	VG.B53F.50.G18F.E16.SFO	VG.B53 suction cup, FDA-compliant silicone, 50 Shore, G1/8" female, 16 mm hex with silicone foam ring	0321572
D	VG.B53F.50.G18M.E16.SFO	VG.B53 suction cup, FDA-compliant silicone, 50 Shore, G1/8" male, 16 mm hex with silicone foam ring	0321573
E	VG.B53F.50.G14F.E16.SFO	VG.B53 suction cup, FDA-compliant silicone, 50 Shore, G1/4" female, 16 mm hex with silicone foam ring	0321574
F	VG.B53F.50.G14M.E17.SFO	VG.B53 suction cup, FDA-compliant silicone, 50 Shore, G1/4" male, 17 mm hex with silicone foam ring	0321575

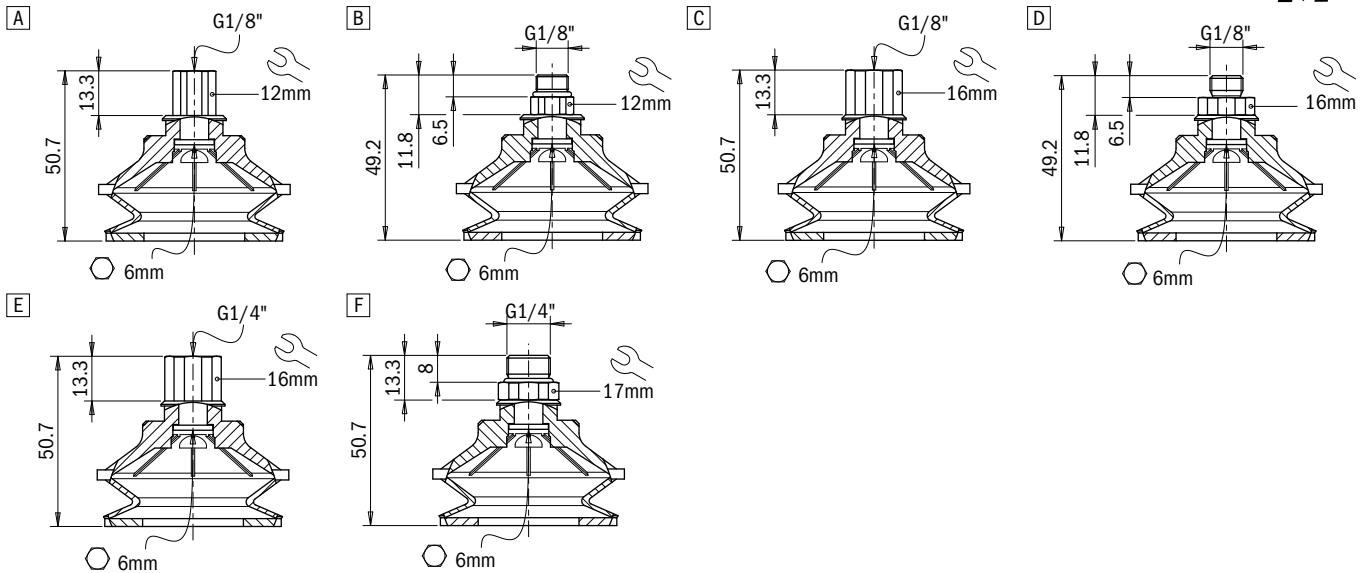

Identification codes

Drawing	Alphanumeric code	Suction cups	Order code
A	VG.B53F.SFO	VG.B53 suction cup in FDA-compliant silicone, 50 Shore, with silicone foam ring	0321570

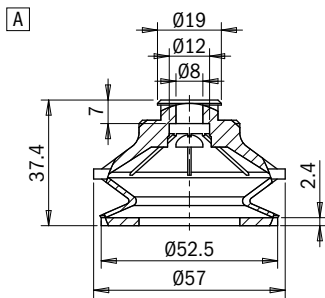

Identification codes

Drawing	Alphanumeric code	Fittings	Order code
A	FT.G18F.E12	G1/8" female fitting, 12 mm hex	2321422
B	FT.G18M.E12	G1/8" male fitting, 12 mm hex	2321424
C	FT.G18F.E16	G1/8" female fitting, 16 mm hex	2321426
D	FT.G18M.E16	G1/8" male fitting, 16 mm hex	2321428
E	FT.G14F.E16	G1/4" female fitting, 16 mm hex	2321430
F	FT.G14M.E17	G1/4" male fitting, 17 mm hex	2321432

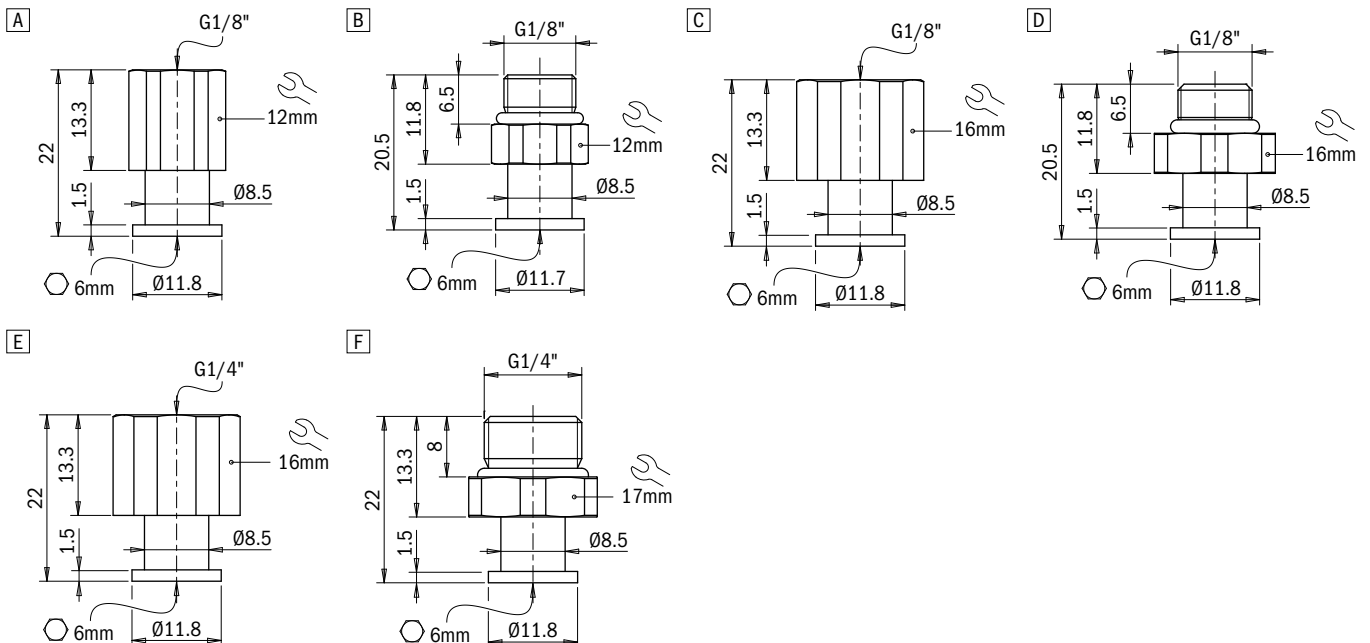

Suction cups / FDA-compliant silicone

VG.LB6F bellows suction cups in FDA-compliant silicone

- Food-grade silicone compound (FDA-approved)
- Suitable for high working temperatures
- Enables to compensate for height differences and work with uneven or porous surfaces
- Ideal for leafing through and picking up fine items

Application example

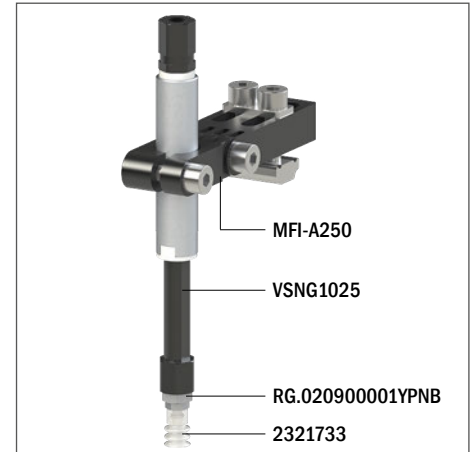

Technical data

Material	Lifting force [N] perpendicular to the surface, at various vacuum levels			Lifting force [N] parallel to the surface, at various vacuum levels			Volume [cm ³]	Min curve radius [mm]	Max vert. movement [mm]	Suction cup weight [g]
	-20 kPa	-60 kPa	-90 kPa	-20 kPa	-60 kPa	-90 kPa				
SIL 50 FDA	0.4	1.1	1.7	–	–	–	0.033	8	3	0.1

Technical features

Material	Color	Hardness	Temperature range
Silicone, FDA SIL	Transparent	50 Shore	-94 - +392 °F

Identification codes			
Drawing	Alphanumeric code	Suction cups with fitting	Order code
A	VG.LB6F.50.M3M.E5	VG.LB6 suction cup, FDA-compliant silicone, 50 Shore, M3 male, 5 mm hex	2321733
B	VG.LB6F.50.M5M.E8	VG.LB6 suction cup, FDA-compliant silicone, 50 Shore, M5 male, 8 mm hex	2321033

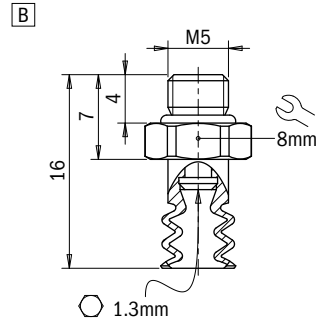
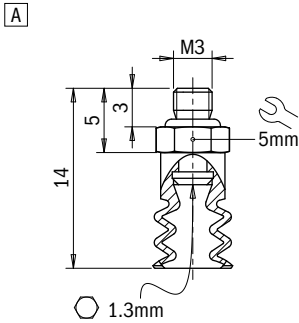

Identification codes			
Drawing	Alphanumeric code	Suction cups	Order code
A	VG.LB6F.50	VG.LB6 suction cup, FDA-compliant silicone, 50 Shore	2321734

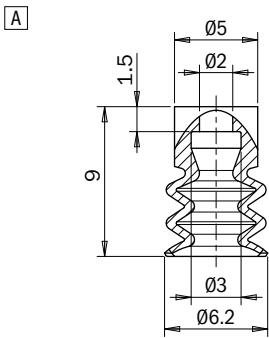

Identification codes			
Drawing	Alphanumeric code	Fittings	Order code
A	FT.M3M.E5	M3 male fitting, 5 mm hex	2321402
B	FT.M5M.E8.06	M5 male fitting, 8 mm hex	2321005

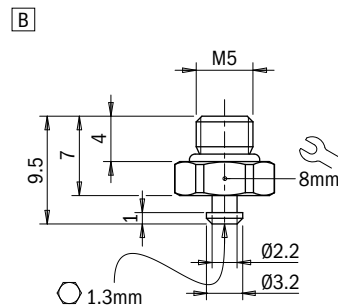
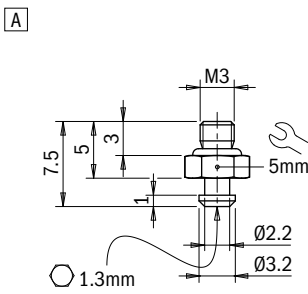

Suction cups / FDA-compliant silicone

VG.LB9F bellows suction cups in FDA-compliant silicone

- Food-grade silicone compound (FDA-approved)
- Suitable for high working temperatures
- Enables to compensate for height differences and work with uneven or porous surfaces
- Ideal for leafing through and picking up fine items



Application example



Technical data

Material	Lifting force [N] perpendicular to the surface, at various vacuum levels			Lifting force [N] parallel to the surface, at various vacuum levels			Volume [cm ³]	Min curve radius [mm]	Max vert. movement [mm]	Suction cup weight [g]
	-20 kPa	-60 kPa	-90 kPa	-20 kPa	-60 kPa	-90 kPa				
SIL 50 FDA	1.1	3	4.2	–	–	–	0.15	10	4	0.6

Technical features

Material	Color	Hardness	Temperature range
Silicone, FDA SIL	Transparent	50 Shore	-94 - +392 °F

Identification codes			
Drawing	Alphanumeric code	Suction cups with fitting	Order code
A	VG.LB9F.50.M5F.E8	VG.LB9 suction cup, FDA-compliant silicone, 50 Shore, M5 female, 8 mm hex	2321735
B	VG.LB9F.50.M5M.E8	VG.LB9 suction cup, FDA-compliant silicone, 50 Shore, M5 male, 8 mm hex	2321737
C	VG.LB9F.50.G18F.E13	VG.LB9 suction cup, FDA-compliant silicone, 50 Shore, G1/8" female, 13 mm hex	2321738
D	VG.LB9F.50.G18M.E13	VG.LB9 suction cup, FDA-compliant silicone, 50 Shore, G1/8" male, 13 mm hex	2321739

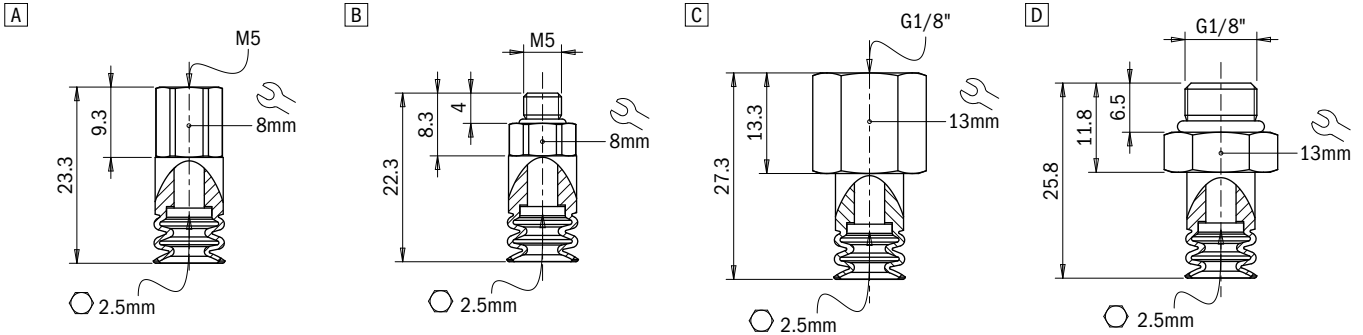

Identification codes			
Drawing	Alphanumeric code	Suction cups	Order code
A	VG.LB9F.50	VG.LB9 suction cup, FDA-compliant silicone, 50 Shore	2321736

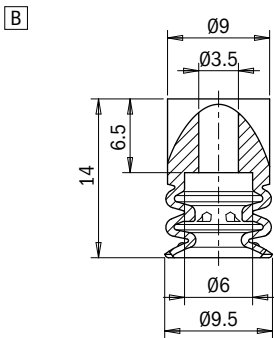

Identification codes			
Drawing	Alphanumeric code	Fittings	Order code
A	FT.M5F.E8	M5 female fitting, 8 mm hex	2321408
B	FT.M5M.E8	M5 male fitting, 8 mm hex	2321410
C	FT.G18F.E13	G1/8" female fitting, 13 mm hex	2321412
D	FT.G18M.E13	G1/8" male fitting, 13 mm hex	2321414

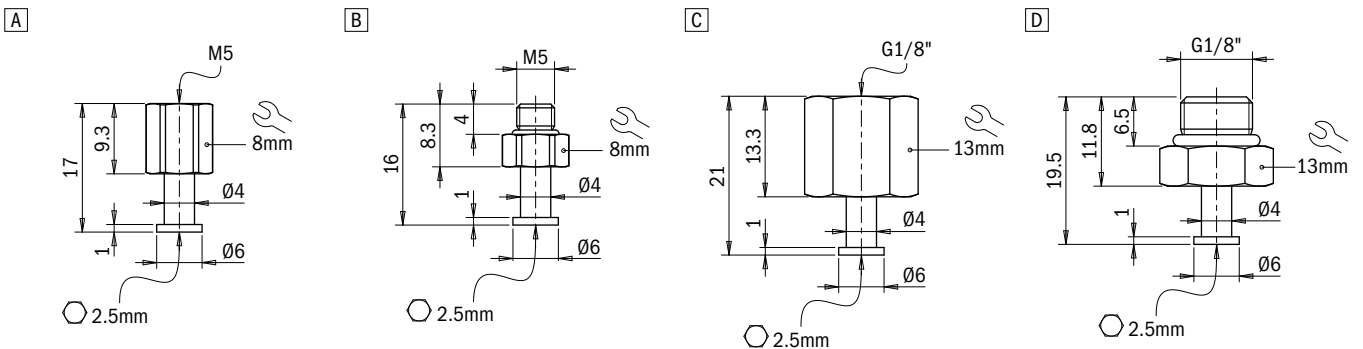

Suction cups / FDA-compliant silicone

VG.LB11F bellows suction cups in FDA-compliant silicone

- Food-grade silicone compound (FDA-approved)
- Suitable for high working temperatures
- Enables to compensate for height differences and work with uneven or porous surfaces
- Ideal for leafing through and picking up fine items

Application example

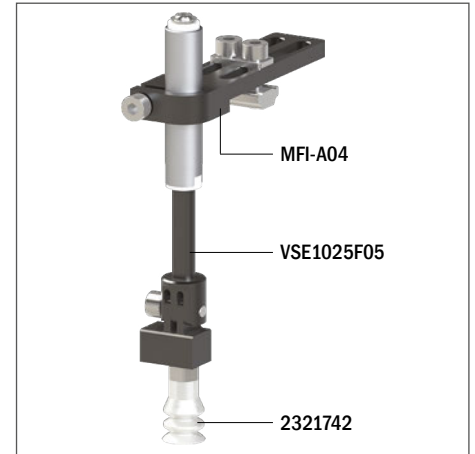

Technical data

Material	Lifting force [N] perpendicular to the surface, at various vacuum levels			Lifting force [N] parallel to the surface, at various vacuum levels			Volume [cm ³]	Min curve radius [mm]	Max vert. movement [mm]	Suction cup weight [g]
	-20 kPa	-60 kPa	-90 kPa	-20 kPa	-60 kPa	-90 kPa				
SIL 50 FDA	1.7	4.3	6.6	–	–	–	0.6	13	7	0.6

Technical features

Material	Color	Hardness	Temperature range
Silicone, FDA SIL	Transparent	50 Shore	-94 - +392 °F

Identification codes			
Drawing	Alphanumeric code	Suction cups with fitting	Order code
A	VG.LB11F.50.M5F.E8	VG.LB11 suction cup, FDA-compliant silicone, 50 Shore, M5 female, 8 mm hex	2321740
B	VG.LB11F.50.M5M.E8	VG.LB11 suction cup, FDA-compliant silicone, 50 Shore, M5 male, 8 mm hex	2321742
C	VG.LB11F.50.G18F.E13	VG.LB11 suction cup, FDA-compliant silicone, 50 Shore, G1/8" female, 13 mm hex	2321743
D	VG.LB11F.50.G18M.E13	VG.LB11 suction cup, FDA-compliant silicone, 50 Shore, G1/8" male, 13 mm hex	2321744

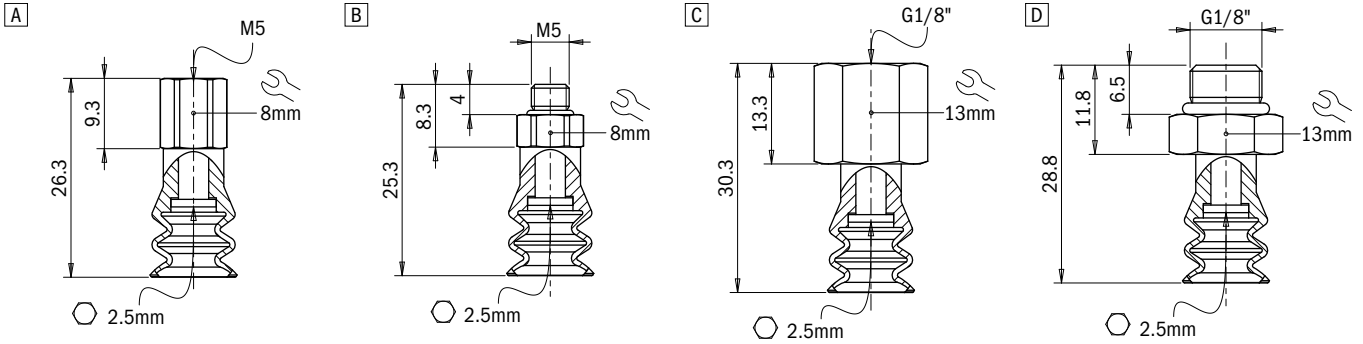

Identification codes			
Drawing	Alphanumeric code	Suction cups	Order code
A	VG.LB11F.50	VG.LB11 suction cup, FDA-compliant silicone, 50 Shore	2321741

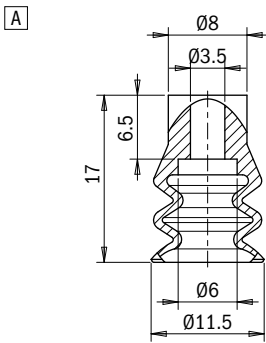

Identification codes			
Drawing	Alphanumeric code	Fittings	Order code
A	FT.M5F.E8	M5 female fitting, 8 mm hex	2321408
B	FT.M5M.E8	M5 male fitting, 8 mm hex	2321410
C	FT.G18F.E13	G1/8" female fitting, 13 mm hex	2321412
D	FT.G18M.E13	G1/8" male fitting, 13 mm hex	2321414

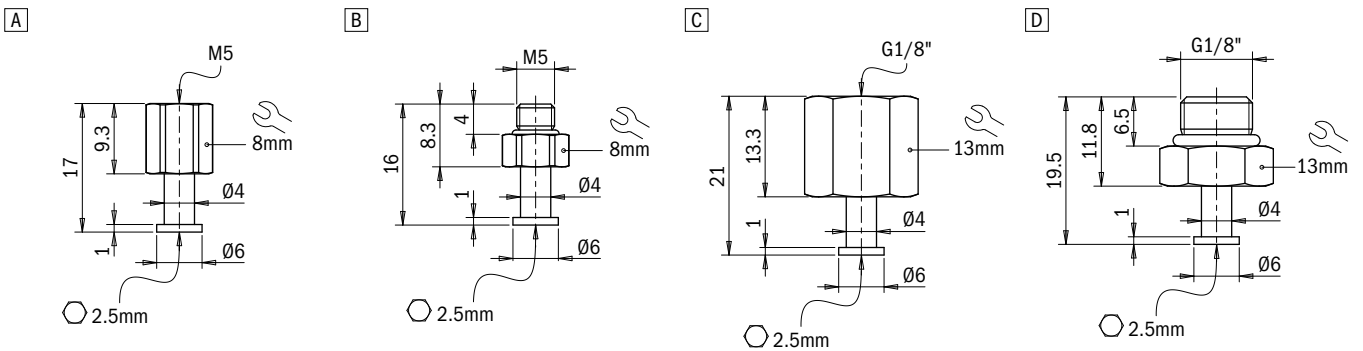

Suction cups / FDA-compliant silicone

VG.LB16F bellows suction cups in FDA-compliant silicone

- Food-grade silicone compound (FDA-approved)
- Suitable for high working temperatures
- Enables to compensate for height differences and work with uneven or porous surfaces
- Ideal for leafing through and picking up fine items

Application example

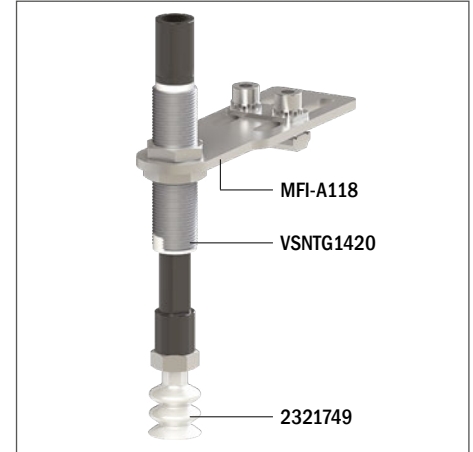

Technical data

Material	Lifting force [N] perpendicular to the surface, at various vacuum levels			Lifting force [N] parallel to the surface, at various vacuum levels			Volume [cm ³]	Min curve radius [mm]	Max vert. movement [mm]	Suction cup weight [g]
	-20 kPa	-60 kPa	-90 kPa	-20 kPa	-60 kPa	-90 kPa				
SIL 50 FDA	3.6	9.4	13.2	–	–	–	1.92	18	9	1.1

Technical features

Material	Color	Hardness	Temperature range
Silicone, FDA SIL	Transparent	50 Shore	-94 - +392 °F

Identification codes

Drawing	Alphanumeric code	Suction cups with fitting	Order code
A	VG.LB16F.50.M5F.E8	VG.LB16 suction cup, FDA-compliant silicone, 50 Shore, M5 female, 8 mm hex	2321745
B	VG.LB16F.50.M5M.E8	VG.LB16 suction cup, FDA-compliant silicone, 50 Shore, M5 male, 8 mm hex	2321747
C	VG.LB16F.50.G18F.E13	VG.LB16 suction cup, FDA-compliant silicone, 50 Shore, G1/8" female, 13 mm hex	2321748
D	VG.LB16F.50.G18M.E13	VG.LB16 suction cup, FDA-compliant silicone, 50 Shore, G1/8" male, 13 mm hex	2321749

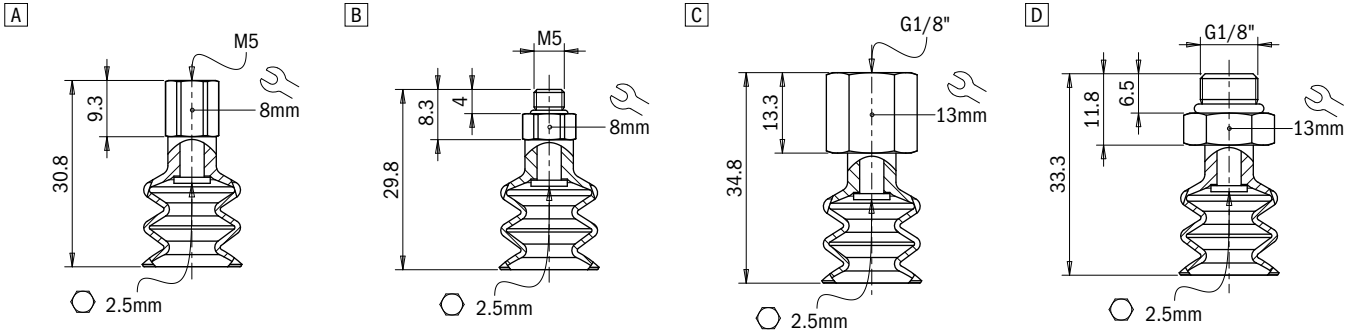

Identification codes

Drawing	Alphanumeric code	Suction cups	Order code
A	VG.LB16F.50	VG.LB16 suction cup, FDA-compliant silicone, 50 Shore	2321746

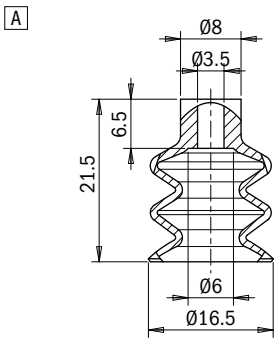

Identification codes

Drawing	Alphanumeric code	Fittings	Order code
A	FT.M5F.E8	M5 female fitting, 8 mm hex	2321408
B	FT.M5M.E8	M5 male fitting, 8 mm hex	2321410
C	FT.G18F.E13	G1/8" female fitting, 13 mm hex	2321412
D	FT.G18M.E13	G1/8" male fitting, 13 mm hex	2321414

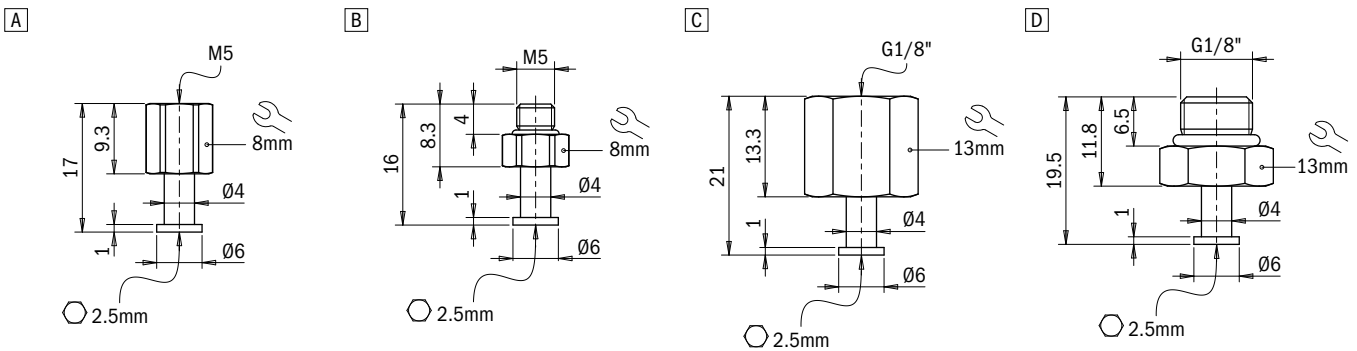

Suction cups / FDA-compliant silicone

VG.LB22F bellows suction cups in FDA-compliant silicone

- Food-grade silicone compound (FDA-approved)
- Suitable for high working temperatures
- Enables to compensate for height differences and work with uneven or porous surfaces
- Ideal for leafing through and picking up fine items

Application example

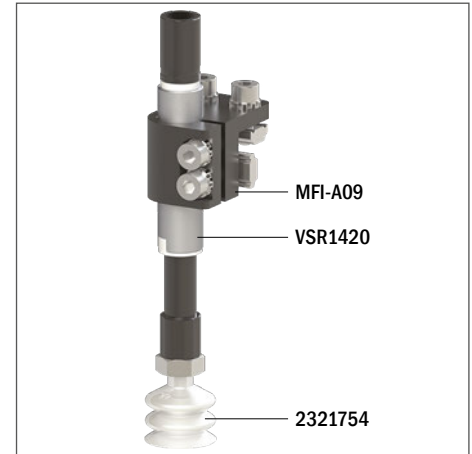

Technical data

Material	Lifting force [N] perpendicular to the surface, at various vacuum levels			Lifting force [N] parallel to the surface, at various vacuum levels			Volume [cm ³]	Min curve radius [mm]	Max vert. movement [mm]	Suction cup weight [g]
	-20 kPa	-60 kPa	-90 kPa	-20 kPa	-60 kPa	-90 kPa				
SIL 50 FDA	6.2	16.1	23.4	–	–	–	2	30	18	2.1

Technical features

Material	Color	Hardness	Temperature range
Silicone, FDA SIL	Transparent	50 Shore	-94 - +392 °F

Identification codes			
Drawing	Alphanumeric code	Suction cups with fitting	Order code
A	VG.LB22F.50.M5F.E8	VG.LB22 suction cup, FDA-compliant silicone, 50 Shore, M5 female, 8 mm hex	2321750
B	VG.LB22F.50.M5M.E8	VG.LB22 suction cup, FDA-compliant silicone, 50 Shore, M5 male, 8 mm hex	2321752
C	VG.LB22F.50.G18F.E13	VG.LB22 suction cup, FDA-compliant silicone, 50 Shore, G1/8" female, 13 mm hex	2321753
D	VG.LB22F.50.G18M.E13	VG.LB22 suction cup, FDA-compliant silicone, 50 Shore, G1/8" male, 13 mm hex	2321754

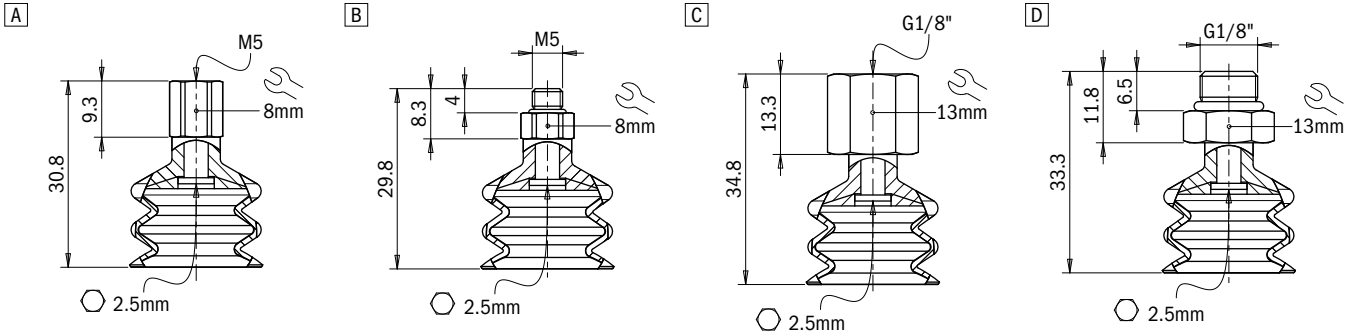

Identification codes			
Drawing	Alphanumeric code	Suction cups	Order code
A	VG.LB22F.50	VG.LB22 suction cup, FDA-compliant silicone, 50 Shore	2321751

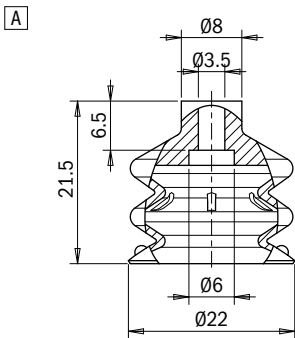

Identification codes			
Drawing	Alphanumeric code	Fittings	Order code
A	FT.M5F.E8	M5 female fitting, 8 mm hex	2321408
B	FT.M5M.E8	M5 male fitting, 8 mm hex	2321410
C	FT.G18F.E13	G1/8" female fitting, 13 mm hex	2321412
D	FT.G18M.E13	G1/8" male fitting, 13 mm hex	2321414

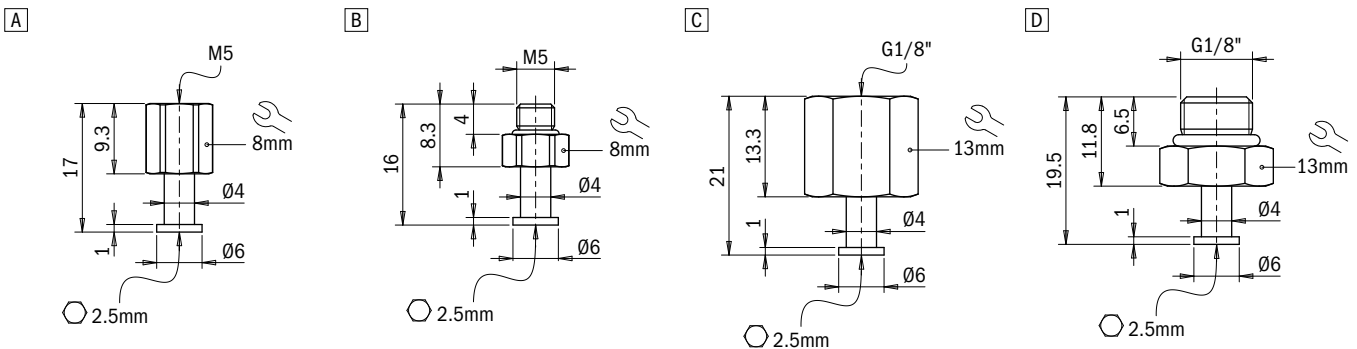

Suction cups / FDA-compliant silicone

VG.LB33F bellows suction cups in FDA-compliant silicone

- Food-grade silicone compound (FDA-approved)
- Suitable for high working temperatures
- Enables to compensate for height differences and work with uneven or porous surfaces
- Ideal for leafing through and picking up fine items

Application example

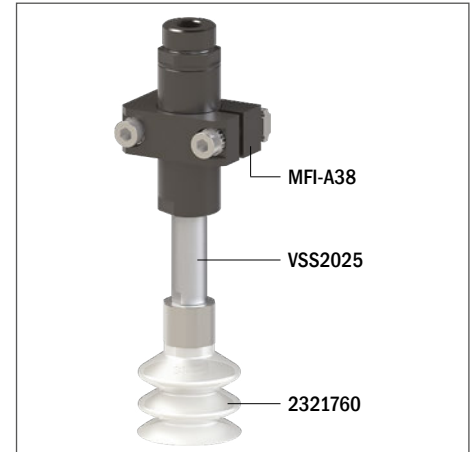

Technical data

Material	Lifting force [N] perpendicular to the surface, at various vacuum levels			Lifting force [N] parallel to the surface, at various vacuum levels			Volume [cm ³]	Min curve radius [mm]	Max vert. movement [mm]	Suction cup weight [g]
	-20 kPa	-60 kPa	-90 kPa	-20 kPa	-60 kPa	-90 kPa				
SIL 50 FDA	13.9	40.4	52.3	–	–	–	10	35	15	6.9

Technical features

Material	Color	Hardness	Temperature range
Silicone, FDA SIL	Transparent	50 Shore	-94 - +392 °F

Identification codes

Drawing	Alphanumeric code	Suction cups with fitting	Order code
A	VG.LB33F.50.G18F.E12	VG.LB33 suction cup, FDA-compliant silicone, 50 Shore, G1/8" female, 12 mm hex	2321757
B	VG.LB33F.50.G18M.E12	VG.LB33 suction cup, FDA-compliant silicone, 50 Shore, G1/8" male, 12 mm hex	2321759
C	VG.LB33F.50.G18F.E16	VG.LB33 suction cup, FDA-compliant silicone, 50 Shore, G1/8" female, 16 mm hex	2321760
D	VG.LB33F.50.G18M.E16	VG.LB33 suction cup, FDA-compliant silicone, 50 Shore, G1/8" male, 16 mm hex	2321761
E	VG.LB33F.50.G14F.E16	VG.LB33 suction cup, FDA-compliant silicone, 50 Shore, G1/4" female, 16 mm hex	2321762
F	VG.LB33F.50.G14M.E17	VG.LB33 suction cup, FDA-compliant silicone, 50 Shore, G1/4" male, 17 mm hex	2321763

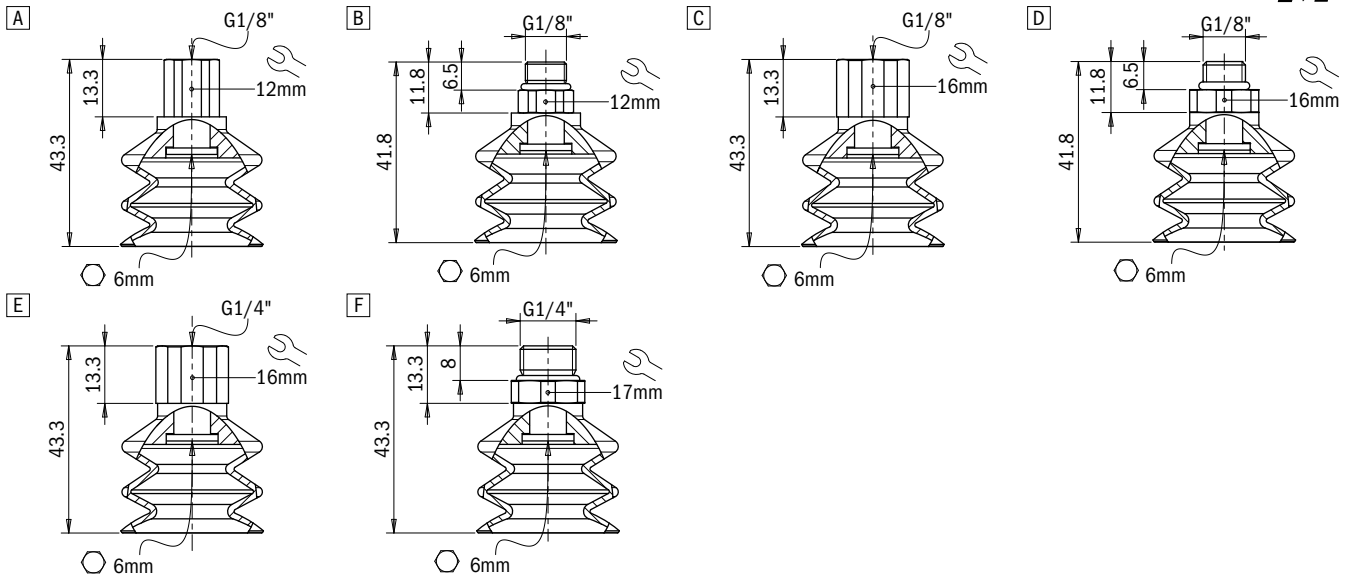

Identification codes

Drawing	Alphanumeric code	Suction cups	Order code
A	VG.LB33F.50	VG.LB33 suction cup, FDA-compliant silicone, 50 Shore	2321758

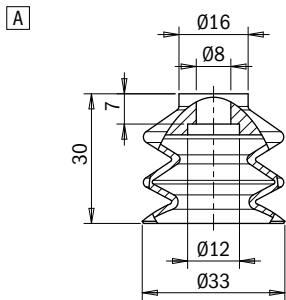

Identification codes

Drawing	Alphanumeric code	Fittings	Order code
A	FT.G18F.E12	G1/8" female fitting, 12 mm hex	2321422
B	FT.G18M.E12	G1/8" male fitting, 12 mm hex	2321424
C	FT.G18F.E16	G1/8" female fitting, 16 mm hex	2321426
D	FT.G18M.E16	G1/8" male fitting, 16 mm hex	2321428
E	FT.G14F.E16	G1/4" female fitting, 16 mm hex	2321430
F	FT.G14M.E17	G1/4" male fitting, 17 mm hex	2321432

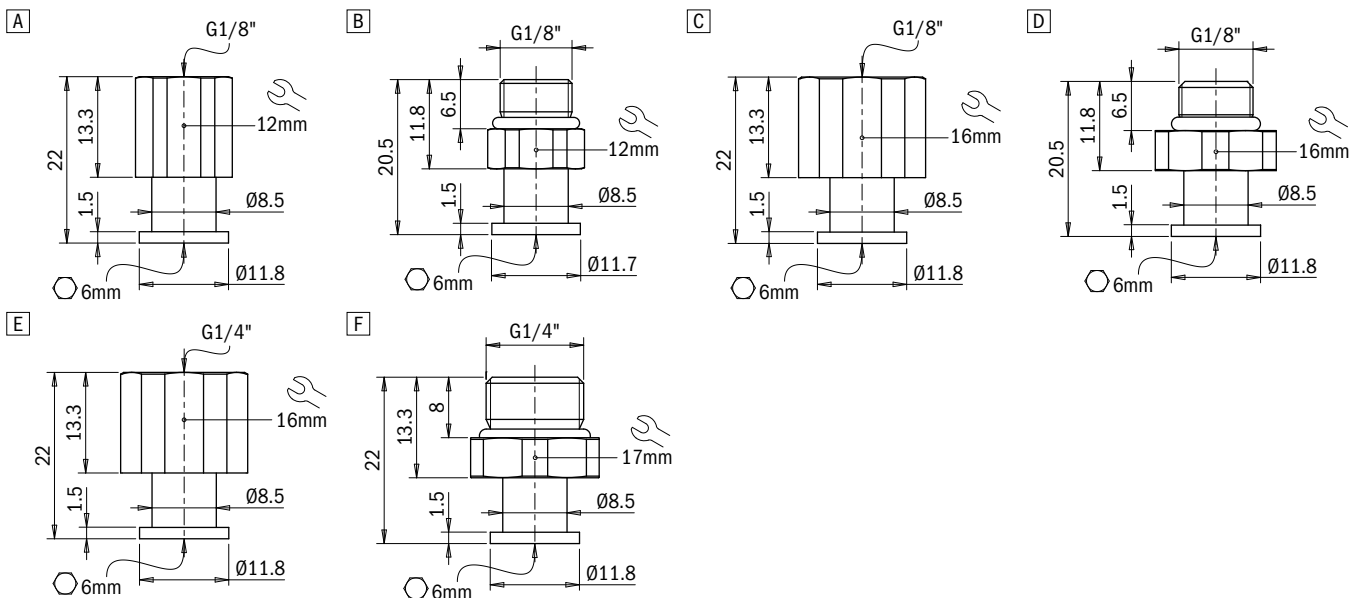

Suction cups / FDA-compliant silicone

VG.LB42F bellows suction cups in FDA-compliant silicone

- Food-grade silicone compound (FDA-approved)
- Suitable for high working temperatures
- Enables to compensate for height differences and work with uneven or porous surfaces
- Ideal for leafing through and picking up fine items



Application example

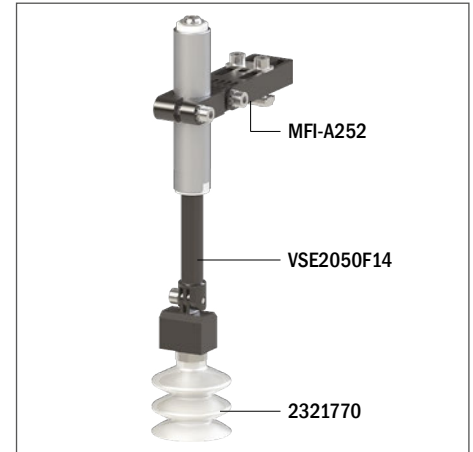

Technical data

Material	Lifting force [N] perpendicular to the surface, at various vacuum levels			Lifting force [N] parallel to the surface, at various vacuum levels			Volume [cm ³]	Min curve radius [mm]	Max vert. movement [mm]	Suction cup weight [g]
	-20 kPa	-60 kPa	-90 kPa	-20 kPa	-60 kPa	-90 kPa				
SIL 50 FDA	25.2	70.2	85.5	—	—	—	19	75	20	15.8

Technical features

Material	Color	Hardness	Temperature range
Silicone, FDA SIL	Transparent	50 Shore	-94 - +392 °F

Identification codes

Drawing	Alphanumeric code	Suction cups with fitting	Order code
A	VG.LB42F.50.G18F.E12	VG.LB42 suction cup, FDA-compliant silicone, 50 Shore, G1/8" female, 12 mm hex	2321764
B	VG.LB42F.50.G18M.E12	VG.LB42 suction cup, FDA-compliant silicone, 50 Shore, G1/8" male, 12 mm hex	2321766
C	VG.LB42F.50.G18F.E16	VG.LB42 suction cup, FDA-compliant silicone, 50 Shore, G1/8" female, 16 mm hex	2321767
D	VG.LB42F.50.G18M.E16	VG.LB42 suction cup, FDA-compliant silicone, 50 Shore, G1/8" male, 16 mm hex	2321768
E	VG.LB42F.50.G14F.E16	VG.LB42 suction cup, FDA-compliant silicone, 50 Shore, G1/4" female, 16 mm hex	2321769
F	VG.LB42F.50.G14M.E17	VG.LB42 suction cup, FDA-compliant silicone, 50 Shore, G1/4" male, 17 mm hex	2321770

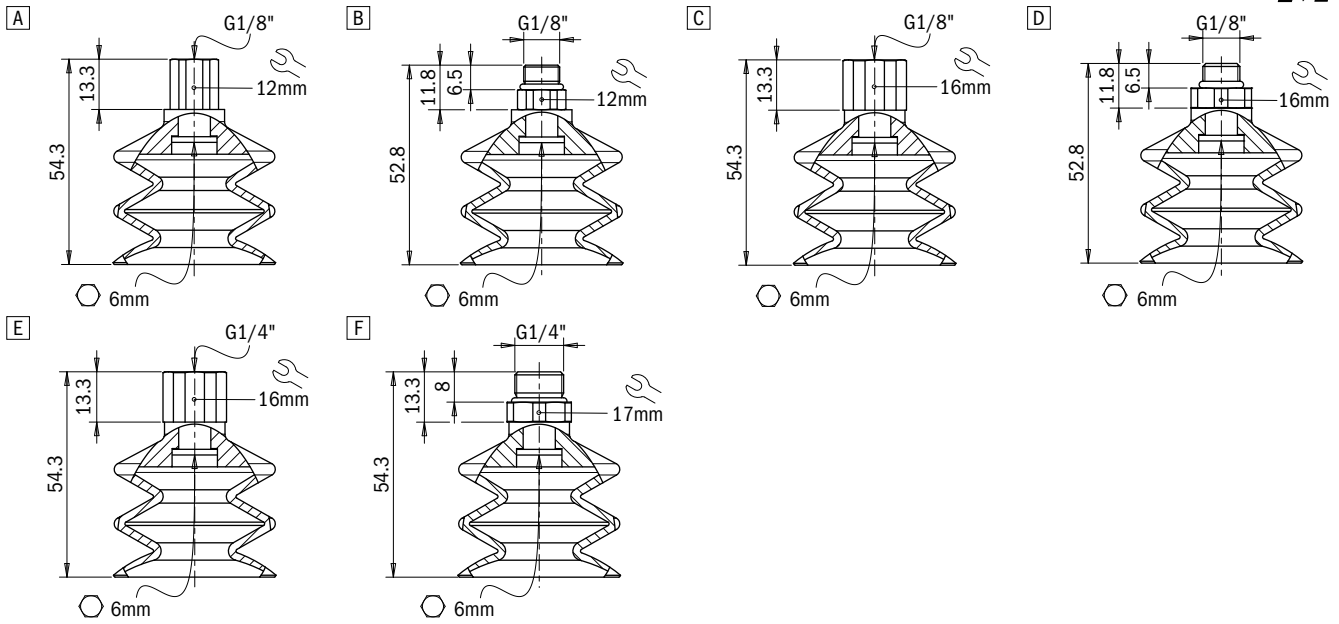

Identification codes

Drawing	Alphanumeric code	Suction cups	Order code
A	VG.LB42F.50	VG.LB42 suction cup, FDA-compliant silicone, 50 Shore	2321765



Click for Pricing & Add to Cart

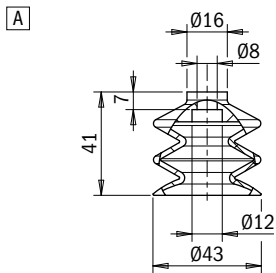

Identification codes

Drawing	Alphanumeric code	Fittings	Order code
A	FT.G18F.E12	G1/8" female fitting, 12 mm hex	2321422
B	FT.G18M.E12	G1/8" male fitting, 12 mm hex	2321424
C	FT.G18F.E16	G1/8" female fitting, 16 mm hex	2321426
D	FT.G18M.E16	G1/8" male fitting, 16 mm hex	2321428
E	FT.G14F.E16	G1/4" female fitting, 16 mm hex	2321430
F	FT.G14M.E17	G1/4" male fitting, 17 mm hex	2321432

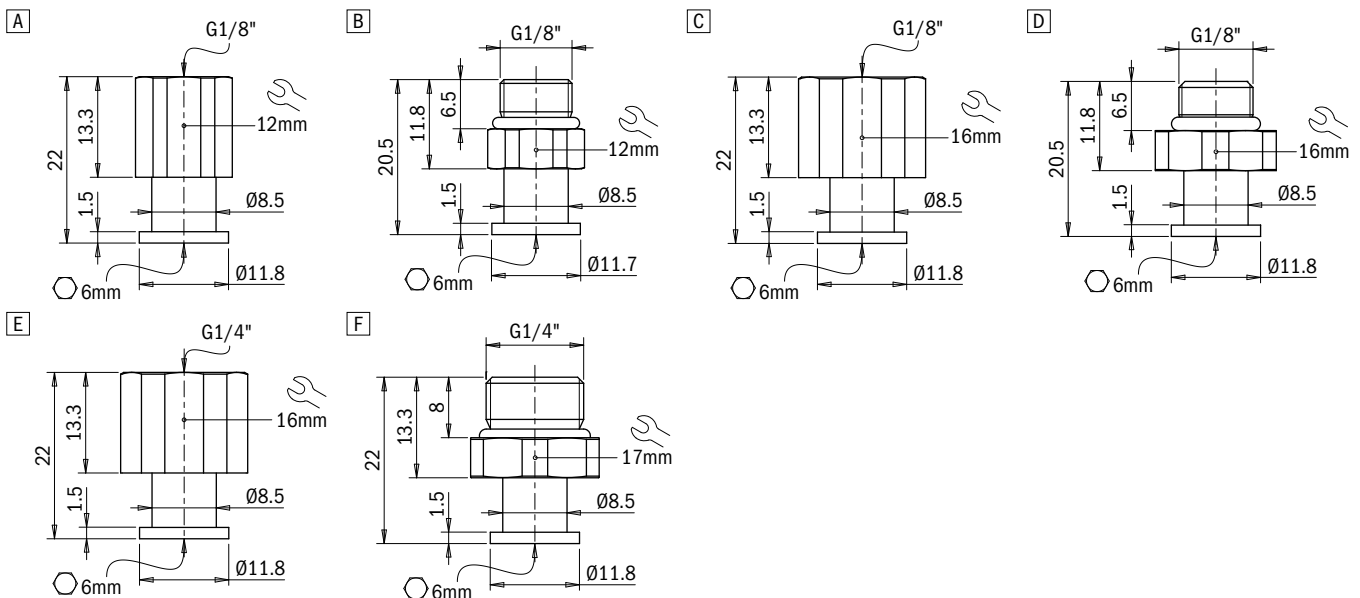

Suction cups / FDA-compliant silicone

VG.LB53F bellows suction cups in FDA-compliant silicone

- Food-grade silicone compound (FDA-approved)
- Suitable for high working temperatures
- Enables to compensate for height differences and work with uneven or porous surfaces
- Ideal for leafing through and picking up fine items



Application example

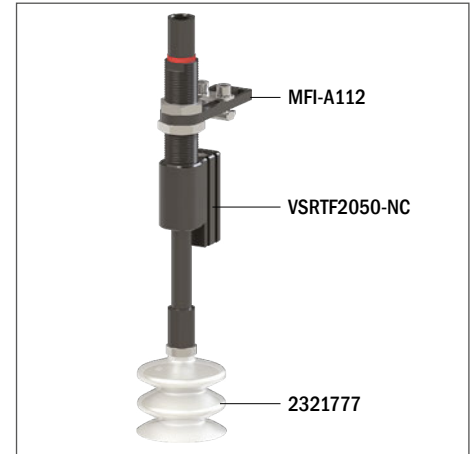

Technical data

Material	Lifting force [N] perpendicular to the surface, at various vacuum levels			Lifting force [N] parallel to the surface, at various vacuum levels			Volume [cm ³]	Min curve radius [mm]	Max vert. movement [mm]	Suction cup weight [g]
	-20 kPa	-60 kPa	-90 kPa	-20 kPa	-60 kPa	-90 kPa				
SIL 50 FDA	34.3	58.1	67.2	–	–	–	37	80	25	26.1

Technical features

Material	Color	Hardness	Temperature range
Silicone, FDA SIL	Transparent	50 Shore	-94 – +392 °F

Identification codes

Drawing	Alphanumeric code	Suction cups with fitting	Order code
A	VG.LB53F.50.G18F.E12	VG.LB53 suction cup, FDA-compliant silicone, 50 Shore, G1/8" female, 12 mm hex	2321771
B	VG.LB53F.50.G18M.E12	VG.LB53 suction cup, FDA-compliant silicone, 50 Shore, G1/8" male, 12 mm hex	2321773
C	VG.LB53F.50.G18F.E16	VG.LB53 suction cup, FDA-compliant silicone, 50 Shore, G1/8" female, 16 mm hex	2321774
D	VG.LB53F.50.G18M.E16	VG.LB53 suction cup, FDA-compliant silicone, 50 Shore, G1/8" male, 16 mm hex	2321775
E	VG.LB53F.50.G14F.E16	VG.LB53 suction cup, FDA-compliant silicone, 50 Shore, G1/4" female, 16 mm hex	2321776
F	VG.LB53F.50.G14M.E17	VG.LB53 suction cup, FDA-compliant silicone, 50 Shore, G1/4" male, 17 mm hex	2321777

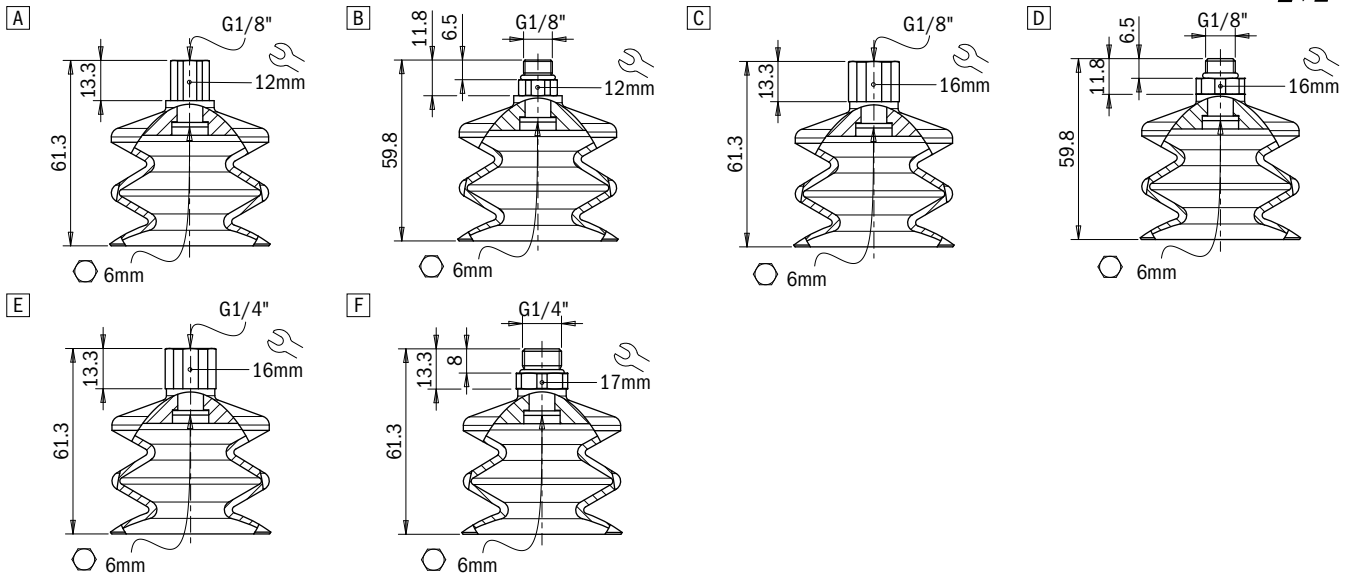

Identification codes

Drawing	Alphanumeric code	Suction cups	Order code
A	VG.LB53F.50	VG.LB53 suction cup, FDA-compliant silicone, 50 Shore	2321772

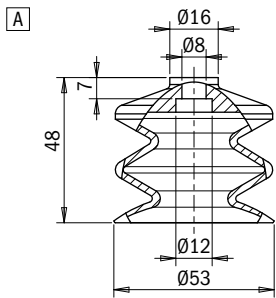

Identification codes

Drawing	Alphanumeric code	Fittings	Order code
A	FT.G18F.E12	G1/8" female fitting, 12 mm hex	2321422
B	FT.G18M.E12	G1/8" male fitting, 12 mm hex	2321424
C	FT.G18F.E16	G1/8" female fitting, 16 mm hex	2321426
D	FT.G18M.E16	G1/8" male fitting, 16 mm hex	2321428
E	FT.G14F.E16	G1/4" female fitting, 16 mm hex	2321430
F	FT.G14M.E17	G1/4" male fitting, 17 mm hex	2321432

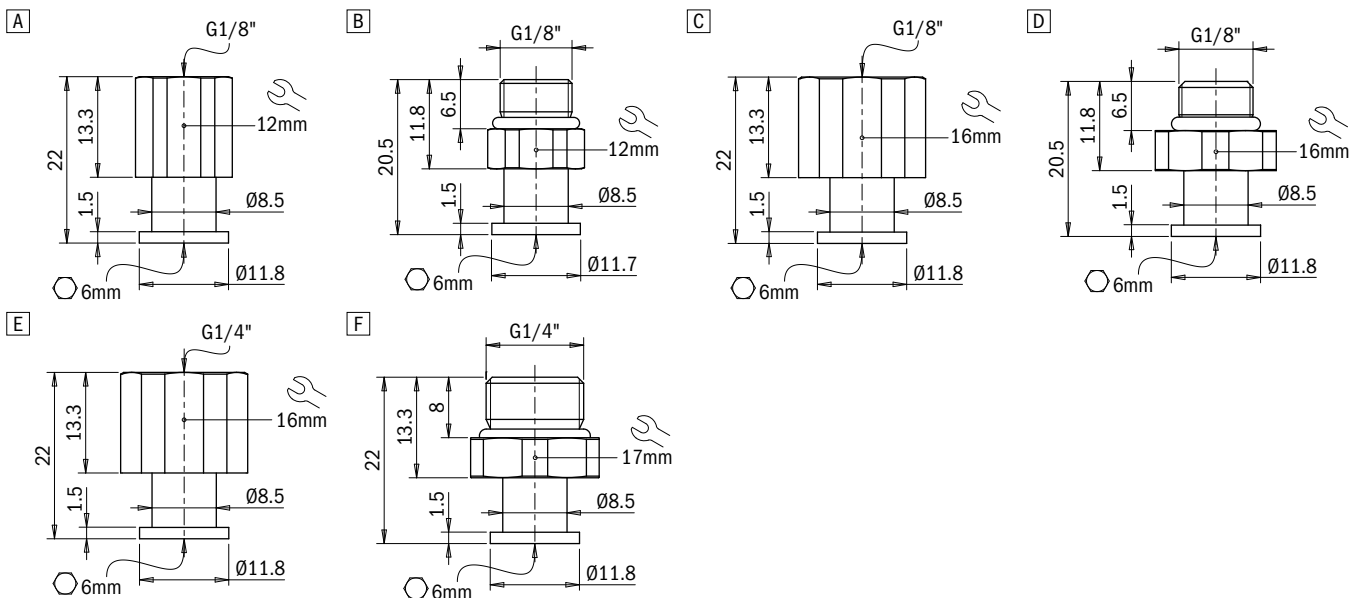

Suction cups / FDA-compliant silicone with ring in silicone foam

VG.LB16F.SFO bellows suction cups in FDA-compliant silicone with silicone foam ring

- Ideal to handle uneven and porous surfaces
- High adaptability on rough wood panels, corrugated sheet metal and non-slip sheet metal
- Ring in mark-free silicone foam
- They enable to compensate for differences in height



Application example

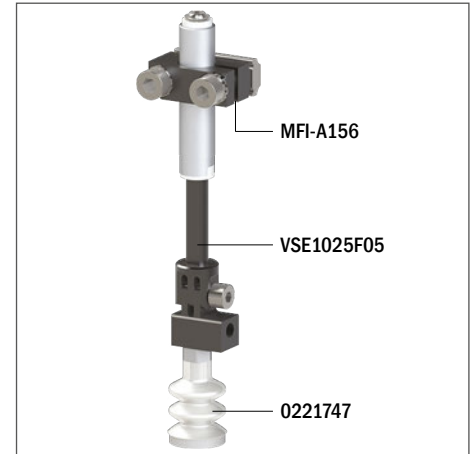

Technical features

Material	Color	Hardness	Temperature range
Silicone, FDA SIL	Transparent	50 Shore	-94 - +392 °F

Identification codes			
Drawing	Alphanumeric code	Suction cups with fitting	Order code
A	VG.LB16F.50.M5F.E8.SFO	VG.LB16 suction cup, FDA-compliant silicone, 50 Shore, M5 female, 8 mm hex with silicone foam ring	0221745
B	VG.LB16F.50.M5M.E8.SFO	VG.LB16 suction cup, FDA-compliant silicone, 50 Shore, M5 male, 8 mm hex with silicone foam ring	0221747
C	VG.LB16F.50.G18F.E13.SFO	VG.LB16 suction cup, FDA-compliant silicone, 50 Shore, G1/8" female, 13 mm hex with silicone foam ring	0221748
D	VG.LB16F.50.G18M.E13.SFO	VG.LB16 suction cup, FDA-compliant silicone, 50 Shore, G1/8" male, 13 mm hex with silicone foam ring	0221749

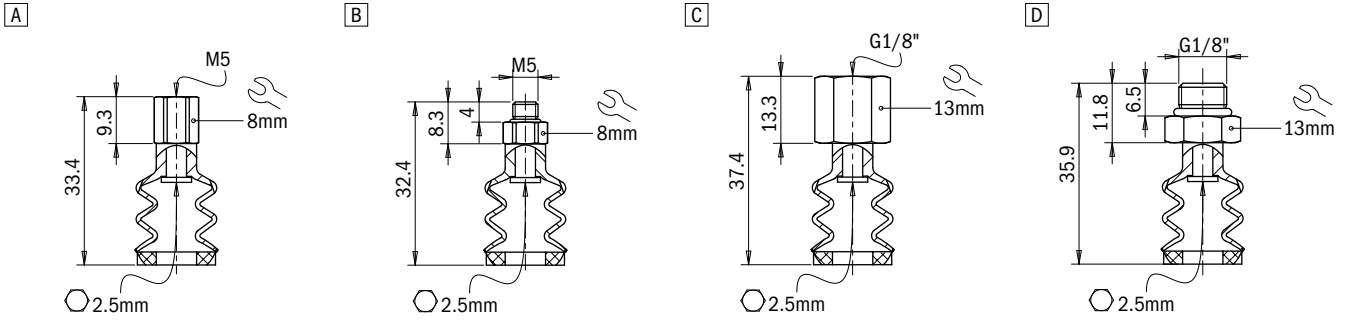

Identification codes			
Drawing	Alphanumeric code	Suction cups	Order code
A	VG.LB16F.50.SFO	VG.LB16 suction cup, FDA-compliant silicone, 50 Shore, with silicone foam ring	0221746

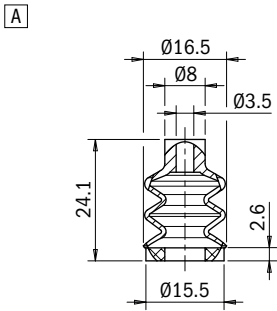

Identification codes			
Drawing	Alphanumeric code	Fittings	Order code
A	FT.M5F.E8	M5 female fitting, 8 mm hex	2321408
B	FT.M5M.E8	M5 male fitting, 8 mm hex	2321410
C	FT.G18F.E13	G1/8" female fitting, 13 mm hex	2321412
D	FT.G18M.E13	G1/8" male fitting, 13 mm hex	2321414

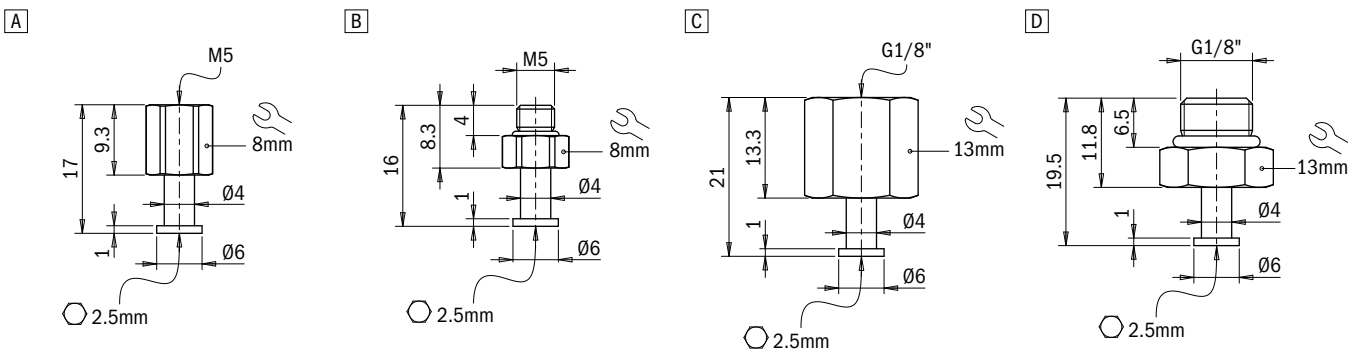

Suction cups / FDA-compliant silicone with ring in silicone foam

VG.LB22F.SFO bellows suction cups in FDA-compliant silicone with silicone foam ring

- Ideal to handle uneven and porous surfaces
- High adaptability on rough wood panels, corrugated sheet metal and non-slip sheet metal
- Ring in mark-free silicone foam
- They enable to compensate for differences in height



Application example

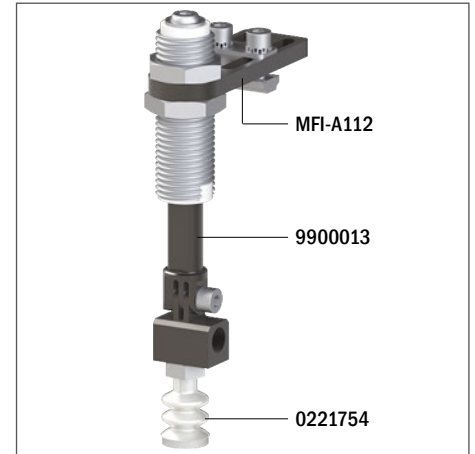

Technical features

Material	Color	Hardness	Temperature range
Silicone, FDA SIL	Transparent	50 Shore	-94 - +392 °F

Identification codes			
Drawing	Alphanumeric code	Suction cups with fitting	Order code
A	VG.LB22F.50.M5F.E8.SFO	VG.LB22 suction cup, FDA-compliant silicone, 50 Shore, M5 female, 8 mm hex with silicone foam ring	0221750
B	VG.LB22F.50.M5M.E8.SFO	VG.LB22 suction cup, FDA-compliant silicone, 50 Shore, M5 male, 8 mm hex with silicone foam ring	0221752
C	VG.LB22F.50.G18F.E13.SFO	VG.LB22 suction cup, FDA-compliant silicone, 50 Shore, G1/8" female, 13 mm hex with silicone foam ring	0221753
D	VG.LB22F.50.G18M.E13.SFO	VG.LB22 suction cup, FDA-compliant silicone, 50 Shore, G1/8" male, 13 mm hex with silicone foam ring	0221754

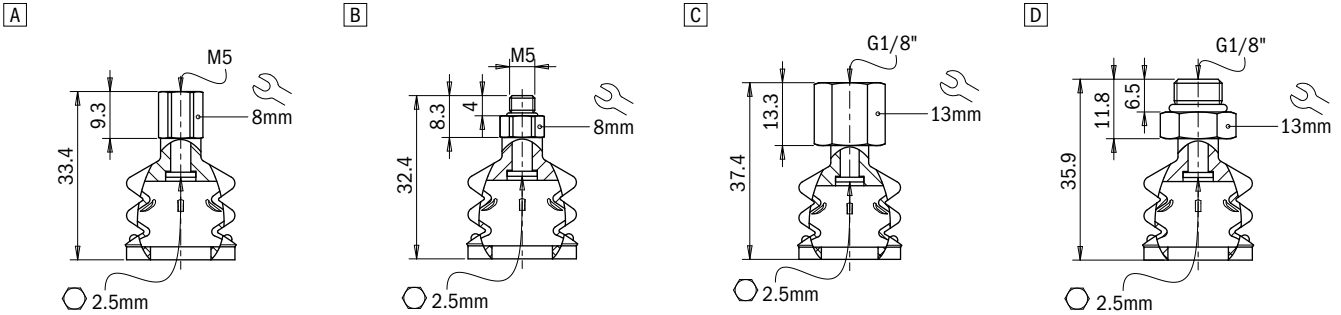

Identification codes			
Drawing	Alphanumeric code	Suction cups	Order code
A	VG.LB22F.50.SFO	VG.LB22 suction cup, FDA-compliant silicone, 50 Shore, with silicone foam ring	0221751

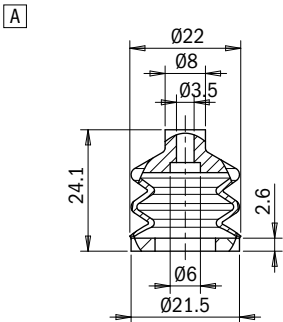

Identification codes			
Drawing	Alphanumeric code	Fittings	Order code
A	FT.M5F.E8	M5 female fitting, 8 mm hex	2321408
B	FT.M5M.E8	M5 male fitting, 8 mm hex	2321410
C	FT.G18F.E13	G1/8" female fitting, 13 mm hex	2321412
D	FT.G18M.E13	G1/8" male fitting, 13 mm hex	2321414

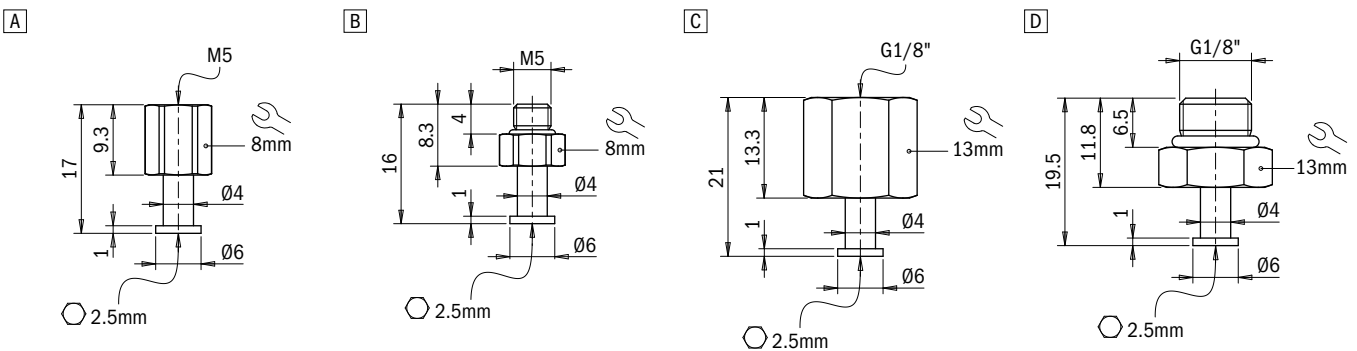

Suction cups / FDA-compliant silicone with ring in silicone foam

VG.LB33F.SFO bellows suction cups in FDA-compliant silicone with silicone foam ring

- Ideal to handle uneven and porous surfaces
- High adaptability on rough wood panels, corrugated sheet metal and non-slip sheet metal
- Ring in mark-free silicone foam
- They enable to compensate for differences in height



Application example

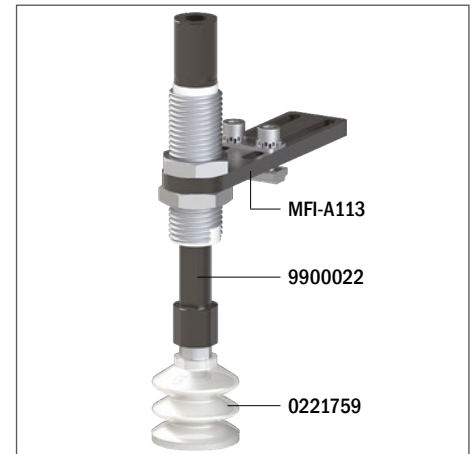

Technical features

Material	Color	Hardness	Temperature range
Silicone, FDA SIL	Transparent	50 Shore	-94 - +392 °F

Identification codes

Drawing	Alphanumeric code	Suction cups with fitting	Order code
A	VG.LB33F.50.G18F.E12.SFO	VG.LB33 suction cup, FDA-compliant silicone, 50 Shore, G1/8" female, 12 mm hex with silicone foam ring	0221757
B	VG.LB33F.50.G18M.E12.SFO	VG.LB33 suction cup, FDA-compliant silicone, 50 Shore, G1/8" male, 12 mm hex with silicone foam ring	0221759
C	VG.LB33F.50.G18F.E16.SFO	VG.LB33 suction cup, FDA-compliant silicone, 50 Shore, G1/8" female, 16 mm hex with silicone foam ring	0221760
D	VG.LB33F.50.G18M.E16.SFO	VG.LB33 suction cup, FDA-compliant silicone, 50 Shore, G1/8" male, 16 mm hex with silicone foam ring	0221761
E	VG.LB33F.50.G14F.E16.SFO	VG.LB33 suction cup, FDA-compliant silicone, 50 Shore, G1/4" female, 16 mm hex with silicone foam ring	0221762
F	VG.LB33F.50.G14M.E17.SFO	VG.LB33 suction cup, FDA-compliant silicone, 50 Shore, G1/4" male, 17 mm hex with silicone foam ring	0221763

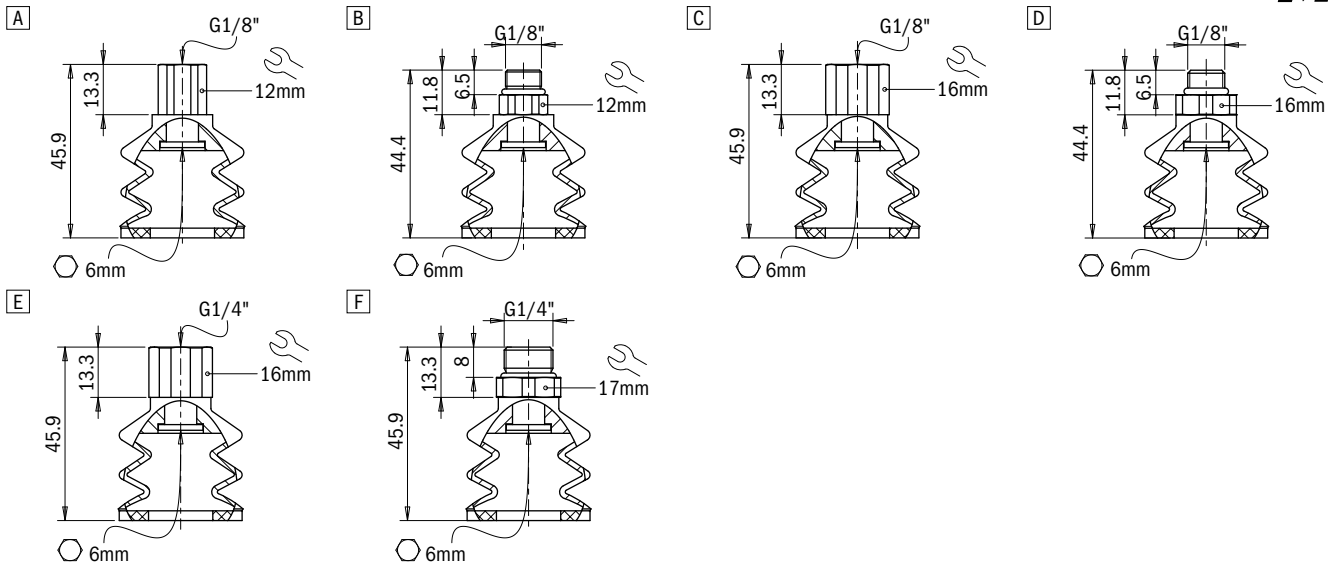

Identification codes

Drawing	Alphanumeric code	Suction cups	Order code
A	VG.LB33F.50.SFO	VG.LB33 suction cup, FDA-compliant silicone, 50 Shore, with silicone foam ring	0221758

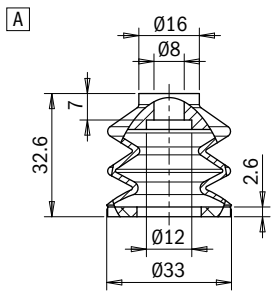

Identification codes

Drawing	Alphanumeric code	Fittings	Order code
A	FT.G18F.E12	G1/8" female fitting, 12 mm hex	2321422
B	FT.G18M.E12	G1/8" male fitting, 12 mm hex	2321424
C	FT.G18F.E16	G1/8" female fitting, 16 mm hex	2321426
D	FT.G18M.E16	G1/8" male fitting, 16 mm hex	2321428
E	FT.G14F.E16	G1/4" female fitting, 16 mm hex	2321430
F	FT.G14M.E17	G1/4" male fitting, 17 mm hex	2321432

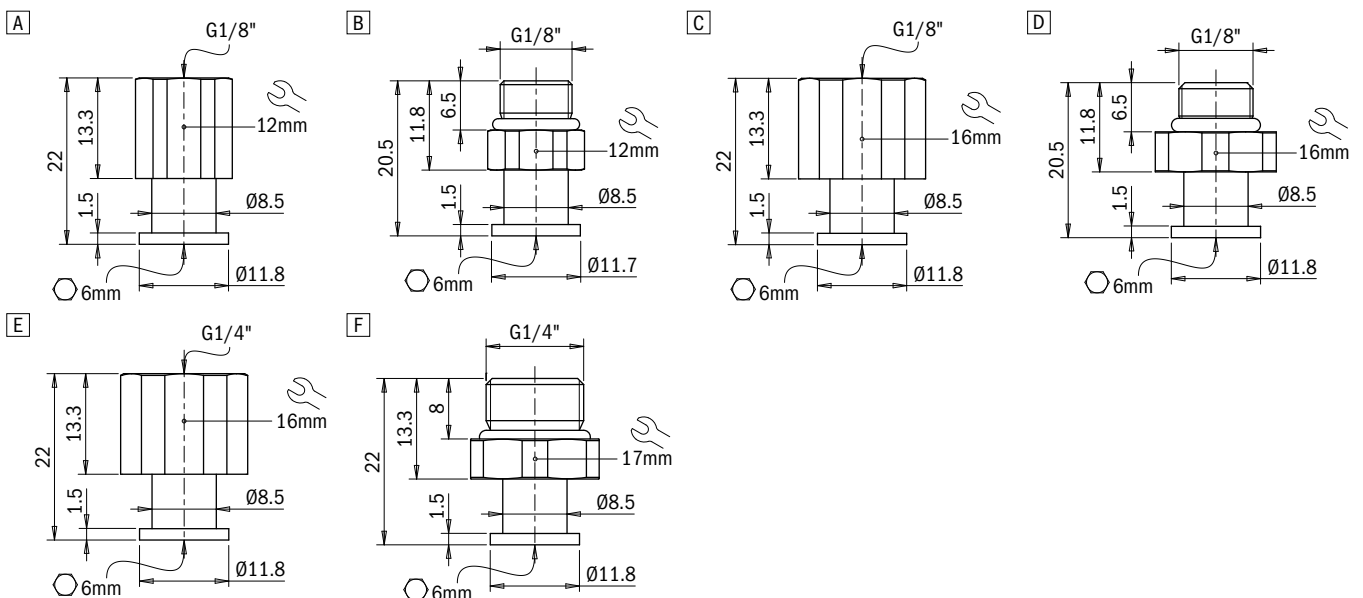

Suction cups / FDA-compliant silicone with ring in silicone foam

VG.LB42F.SFO bellows suction cups in FDA-compliant silicone with silicone foam ring

- Ideal to handle uneven and porous surfaces
- High adaptability on rough wood panels, corrugated sheet metal and non-slip sheet metal
- Ring in mark-free silicone foam
- They enable to compensate for differences in height



Application example

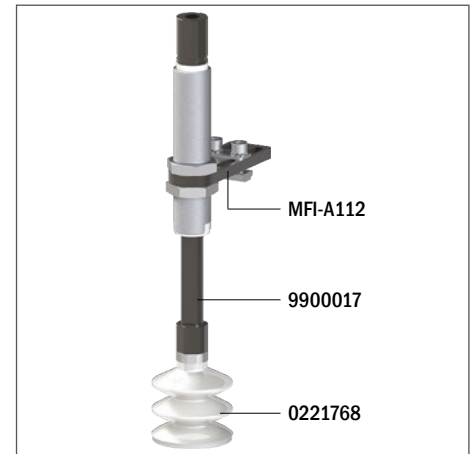

Technical features

Material	Color	Hardness	Temperature range
Silicone, FDA SIL	Transparent	50 Shore	-94 - +392 °F

Identification codes

Drawing	Alphanumeric code	Suction cups with fitting	Order code
A	VG.LB42F.50.G18F.E12.SFO	VG.LB42 suction cup, FDA-compliant silicone, 50 Shore, G1/8" female, 12 mm hex with silicone foam ring	0221764
B	VG.LB42F.50.G18M.E12.SFO	VG.LB42 suction cup, FDA-compliant silicone, 50 Shore, G1/8" male, 12 mm hex with silicone foam ring	0221766
C	VG.LB42F.50.G18F.E16.SFO	VG.LB42 suction cup, FDA-compliant silicone, 50 Shore, G1/8" female, 16 mm hex with silicone foam ring	0221767
D	VG.LB42F.50.G18M.E16.SFO	VG.LB42 suction cup, FDA-compliant silicone, 50 Shore, G1/8" male, 16 mm hex with silicone foam ring	0221768
E	VG.LB42F.50.G14F.E16.SFO	VG.LB42 suction cup, FDA-compliant silicone, 50 Shore, G1/4" female, 16 mm hex with silicone foam ring	0221769
F	VG.LB42F.50.G14M.E17.SFO	VG.LB42 suction cup, FDA-compliant silicone, 50 Shore, G1/4" male, 17 mm hex with silicone foam ring	0221770



[Click for Pricing & Add to Cart](#)

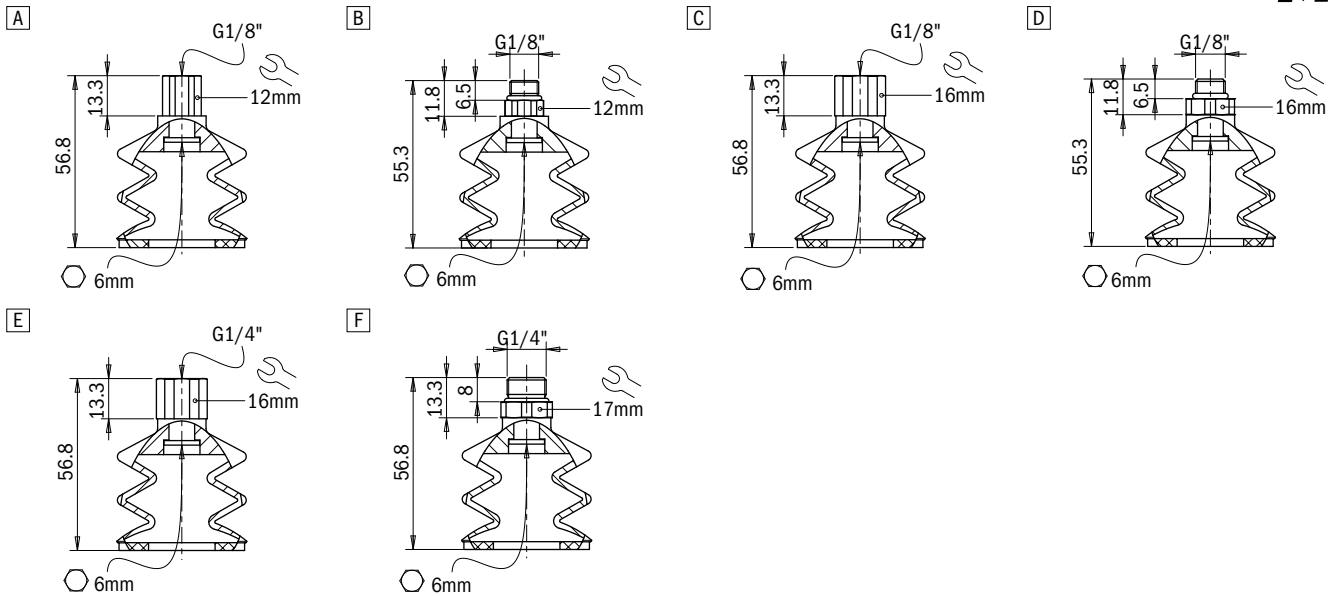

Identification codes

Drawing	Alphanumeric code	Suction cups	Order code
A	VG.LB42F.50.SF0	VG.LB42 suction cup, FDA-compliant silicone, 50 Shore, with silicone foam ring	0221765

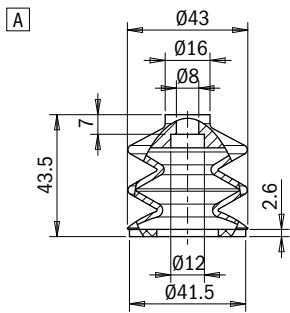

Identification codes

Drawing	Alphanumeric code	Fittings	Order code
A	FT.G18F.E12	G1/8" female fitting, 12 mm hex	2321422
B	FT.G18M.E12	G1/8" male fitting, 12 mm hex	2321424
C	FT.G18F.E16	G1/8" female fitting, 16 mm hex	2321426
D	FT.G18M.E16	G1/8" male fitting, 16 mm hex	2321428
E	FT.G14F.E16	G1/4" female fitting, 16 mm hex	2321430
F	FT.G14M.E17	G1/4" male fitting, 17 mm hex	2321432

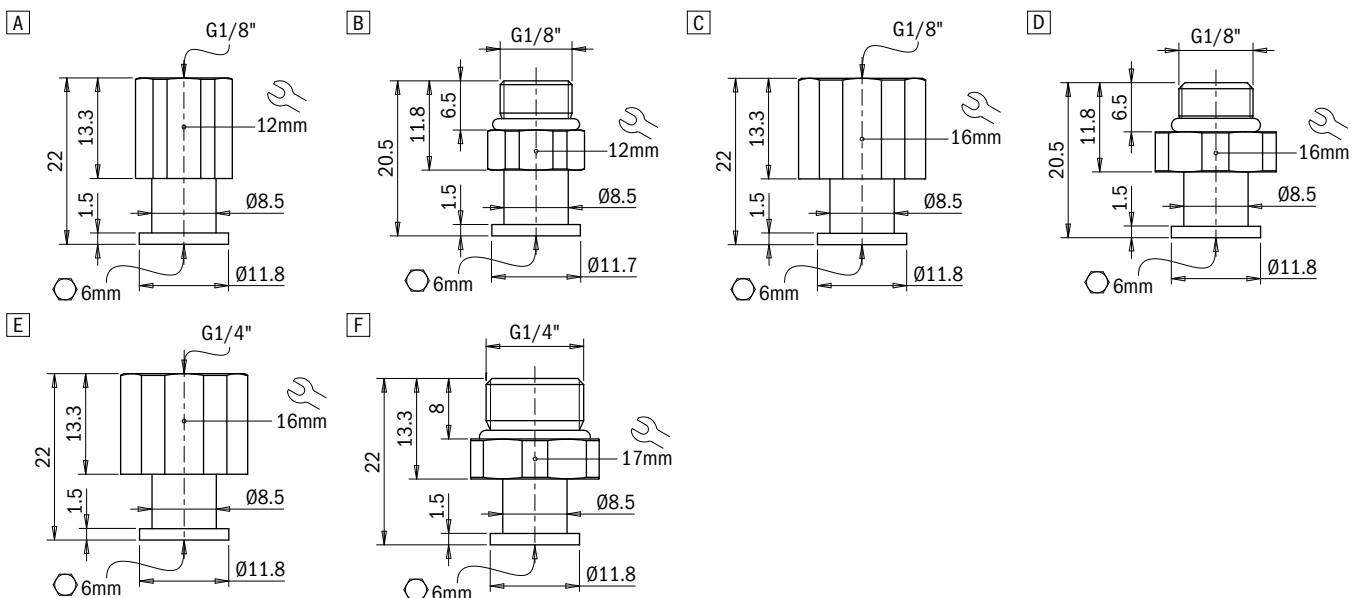

Suction cups / FDA-compliant silicone with ring in silicone foam

VG.LB53F.SFO bellows suction cups in FDA-compliant silicone with silicone foam ring

- Ideal to handle uneven and porous surfaces
- High adaptability on rough wood panels, corrugated sheet metal and non-slip sheet metal
- Ring in mark-free silicone foam
- They enable to compensate for differences in height



Application example

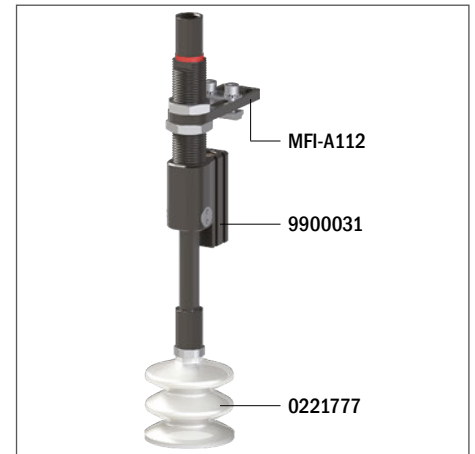

Technical features

Material	Color	Hardness	Temperature range
Silicone, FDA SIL	Transparent	50 Shore	-94 - +392 °F

Identification codes

Drawing	Alphanumeric code	Suction cups with fitting	Order code
A	VG.LB53F.50.G18F.E12.SFO	VG.LB53 suction cup, FDA-compliant silicone, 50 Shore, G1/8" female, 12 mm hex with silicone foam ring	0221771
B	VG.LB53F.50.G18M.E12.SFO	VG.LB53 suction cup, FDA-compliant silicone, 50 Shore, G1/8" male, 12 mm hex with silicone foam ring	0221773
C	VG.LB53F.50.G18F.E16.SFO	VG.LB53 suction cup, FDA-compliant silicone, 50 Shore, G1/8" female, 16 mm hex with silicone foam ring	0221774
D	VG.LB53F.50.G18M.E16.SFO	VG.LB53 suction cup, FDA-compliant silicone, 50 Shore, G1/8" male, 16 mm hex with silicone foam ring	0221775
E	VG.LB53F.50.G14F.E16.SFO	VG.LB53 suction cup, FDA-compliant silicone, 50 Shore, G1/4" female, 16 mm hex with silicone foam ring	0221776
F	VG.LB53F.50.G14M.E17.SFO	VG.LB53 suction cup, FDA-compliant silicone, 50 Shore, G1/4" male, 17 mm hex with silicone foam ring	0221777

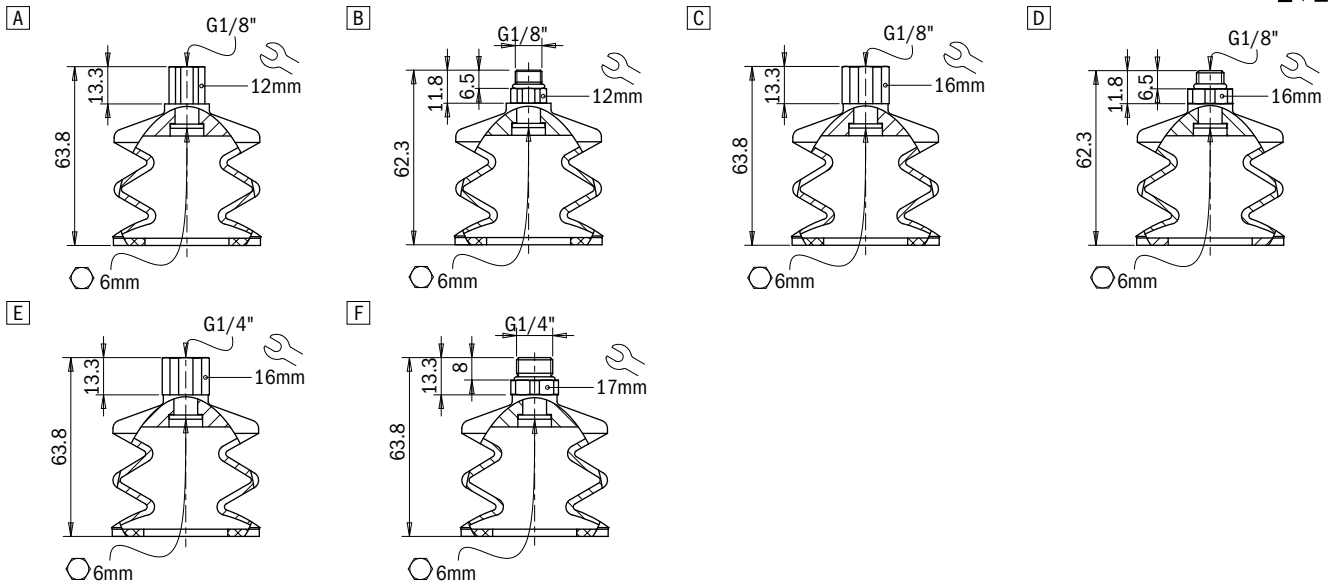

Identification codes

Drawing	Alphanumeric code	Suction cups	Order code
A	VG.LB53F.50.SF0	VG.LB53 suction cup, FDA-compliant silicone, 50 Shore, with silicone foam ring	0221772

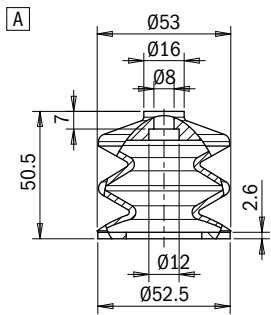

Identification codes

Drawing	Alphanumeric code	Fittings	Order code
A	FT.G18F.E12	G1/8" female fitting, 12 mm hex	2321422
B	FT.G18M.E12	G1/8" male fitting, 12 mm hex	2321424
C	FT.G18F.E16	G1/8" female fitting, 16 mm hex	2321426
D	FT.G18M.E16	G1/8" male fitting, 16 mm hex	2321428
E	FT.G14F.E16	G1/4" female fitting, 16 mm hex	2321430
F	FT.G14M.E17	G1/4" male fitting, 17 mm hex	2321432

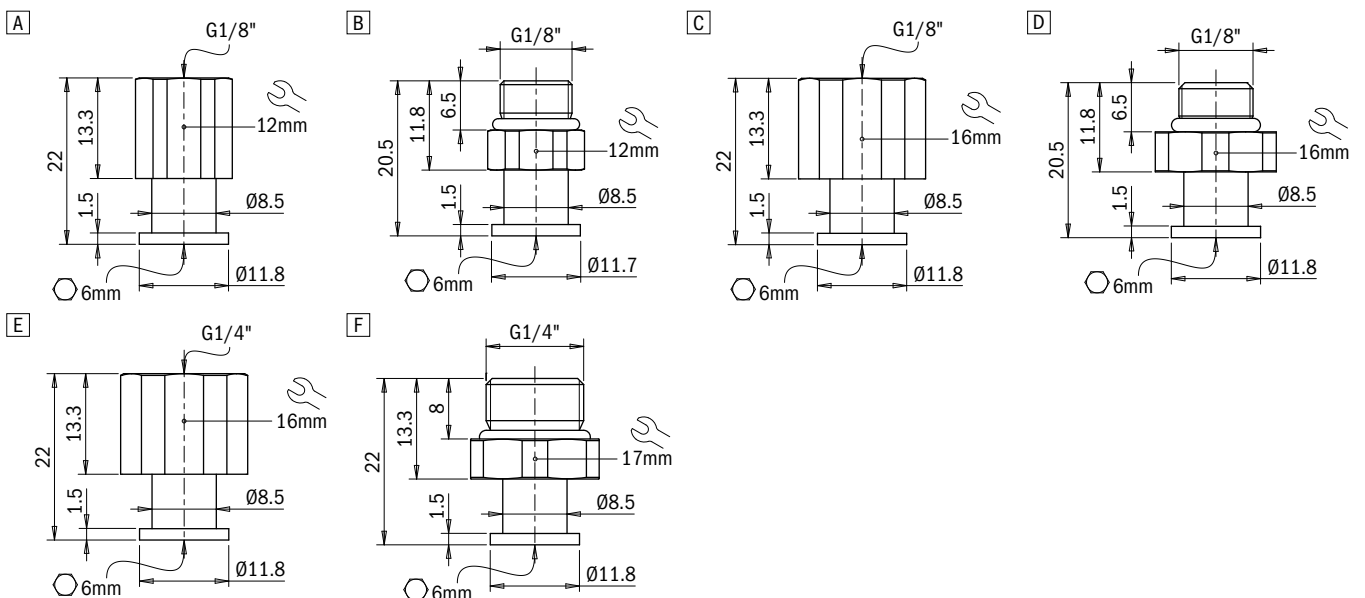

Suction cups / FDA-compliant silicone

VG.FP15F multi-bellows suction cups in FDA-compliant silicone

- The silicone is FDA-compliant and therefore suitable for handling unpackaged food
- Suitable for level compensation
- High vertical movement, useful for separating thin parts

Application example

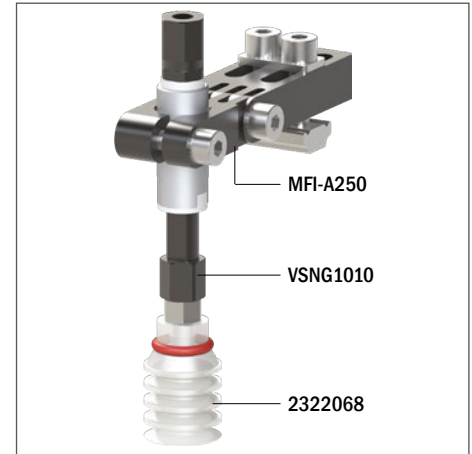

Technical data

Material	Lifting force [N] perpendicular to the surface, at various vacuum levels			Lifting force [N] parallel to the surface, at various vacuum levels			Volume [cm ³]	Min curve radius [mm]	Max vertical movement [mm]	Suction cup weight [g]
	-20 kPa	-60 kPa	-90 kPa	-20 kPa	-60 kPa	-90 kPa				
SIL 50 FDA	0.2	0.23	–	–	–	–	1.05	2	8	0.9

Technical features

Material	Color	Hardness	Temperature range
Silicone, FDA SIL	Transparent	50 Shore	-94 - +392 °F

Identification codes			
Drawing	Alphanumeric code	Suction cups with fitting	Order code
A	VG.FP15F.50.M5M	VG.FP15 suction cup, FDA-compliant silicone, 50 Shore, M5 male	2322068

A

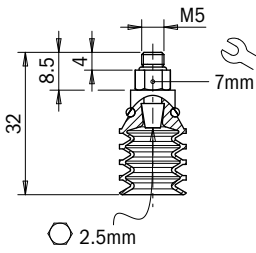

Identification codes			
Drawing	Alphanumeric code	Suction cups	Order code
A	VG.FP15F.50	VG.FP15 suction cup, FDA-compliant silicone, 50 Shore	2322068

A

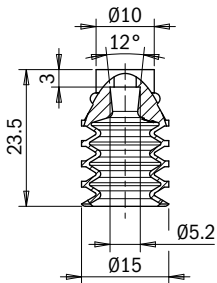

Identification codes			
Drawing	Alphanumeric code	Fittings	Order code
A	FT.M5M	M5 male fitting	1600005

A

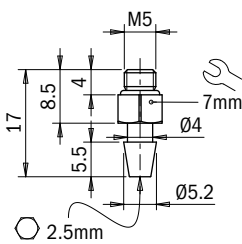

Suction cups / FDA-compliant silicone

VG.FP20F multi-bellows suction cups in FDA-compliant silicone

- The silicone is FDA-compliant and therefore suitable for handling unpackaged food
- Suitable for level compensation
- High vertical movement, useful for separating thin parts
- It can be equipped with a perforated disc to increase stability and to allow the handling of thin films



Application example

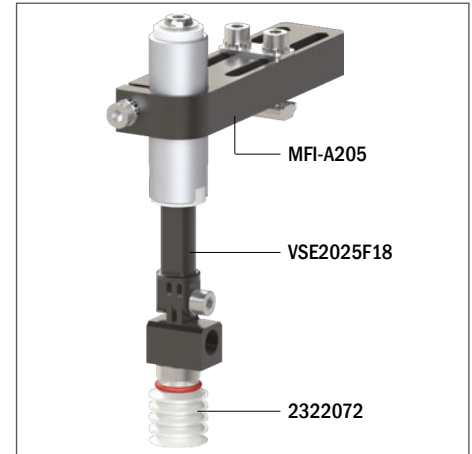

Technical data

Material	Lifting force [N] perpendicular to the surface, at various vacuum levels			Lifting force [N] parallel to the surface, at various vacuum levels			Volume [cm ³]	Min curve radius [mm]	Max vertical movement [mm]	Suction cup weight [g]
	-20 kPa	-60 kPa	-90 kPa	-20 kPa	-60 kPa	-90 kPa				
SIL FDA 50	0.35	0.7	–	–	–	–	4	4	13	3

Technical features

Material	Color	Hardness	Temperature range
Silicone, FDA SIL	Transparent	50 Shore	-94 - +392 °F

Identification codes			
Drawing	Alphanumeric code	Suction cups with fitting	Order code
A	VG.FP20F.50.M5F	VG.FP20 suction cup, FDA-compliant silicone, 50 Shore, M5 female	2322070
B	VG.FP20F.50.G18M	VG.FP20 suction cup, FDA-compliant silicone, 50 Shore, G1/8" male	2322072
C	VG.FP20F.50.G18MF	VG.FP20 suction cup, FDA-compliant silicone, 50 Shore, G1/8" male / M5 female	2322073
D	VG.FP20F.50.G18MFV	VG.FP20 suction cup, FDA-compliant silicone, 50 Shore, G1/8" male/M5 female with valve	2322074

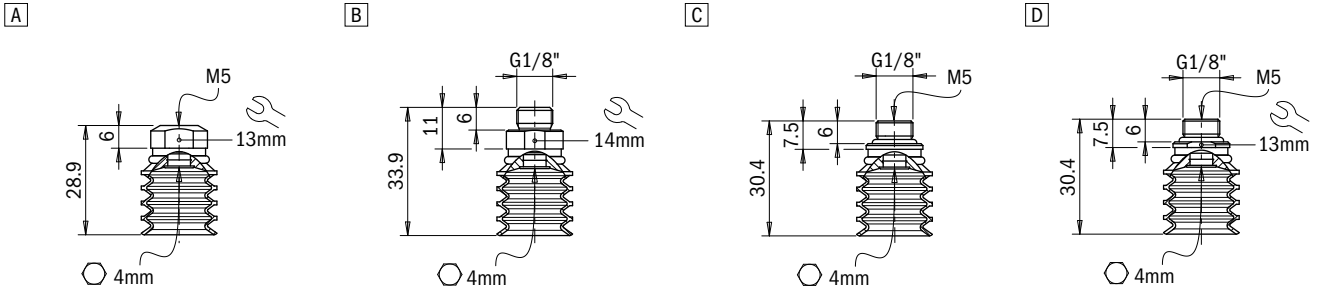

Identification codes			
Drawing	Alphanumeric code	Suction cups	Order code
A	VG.FP20F.50	VG.FP20 suction cup, FDA-compliant silicone, 50 Shore	2322071

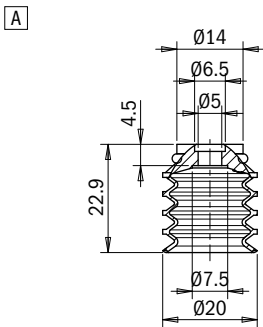

Identification codes			
Drawing	Alphanumeric code	Fittings	Order code
A	FT.M5F	Fitting, M5 female	1700006
B	FT.G18M.17	G1/8" male fitting	1700018
C	FT.G18M.M5F	Fitting, G1/8" male / M5 female	1700016
D	FT.G18M.M5F.VF	G1/8" male / M5 female fitting, with valve	1700017

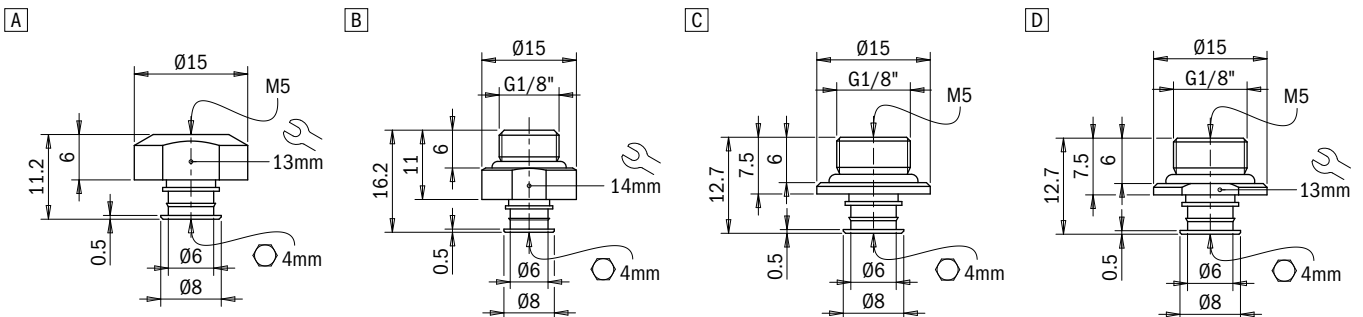

Identification codes		
Alphanumeric code	Disc	Order code
AC.DF20	Perforated disc for thin films, diameter 20 mm	2321780

Suction cups / FDA-compliant silicone

VG.FP30F multi-bellows suction cups in FDA-compliant silicone

- The silicone is FDA-compliant and therefore suitable for handling unpackaged food
- Suitable for level compensation
- High vertical movement, useful for separating thin parts
- It can be equipped with a perforated disc to increase stability and to allow the handling of thin films

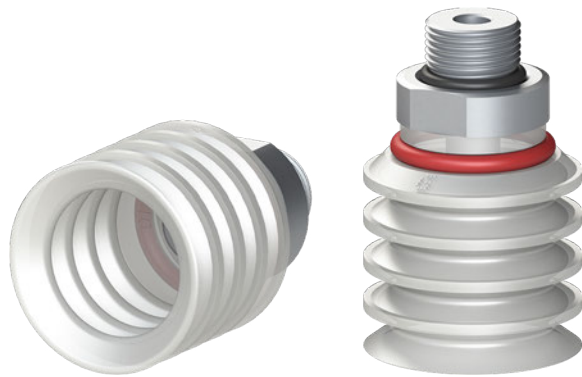

Application example



Technical data

Material	Lifting force [N] perpendicular to the surface, at various vacuum levels			Lifting force [N] parallel to the surface, at various vacuum levels			Volume [cm ³]	Min curve radius [mm]	Max vertical movement [mm]	Suction cup weight [g]
	-20 kPa	-60 kPa	-90 kPa	-20 kPa	-60 kPa	-90 kPa				
SIL FDA 50	6.5	10.3	–	–	–	–	10	8	20	7

Technical features

Material	Color	Hardness	Temperature range
Silicone, FDA SIL	Transparent	50 Shore	-94 - +392 °F

Identification codes			
Drawing	Alphanumeric code	Suction cups with fitting	Order code
A	VG.FP30F.50.G18F	VG.FP30 suction cup, FDA-compliant silicone, 50 Shore, G1/8" female	2322075
B	VG.FP30F.50.G18M	VG.FP30 suction cup, FDA-compliant silicone, 50 Shore, G1/8" male	2322077
C	VG.FP30F.50.G14M	VG.FP30 suction cup, FDA-compliant silicone, 50 Shore, G1/4" male	2322078
D	VG.FP30F.50.G38M	VG.FP30 suction cup, FDA-compliant silicone, 50 Shore, G3/8" male	2322079

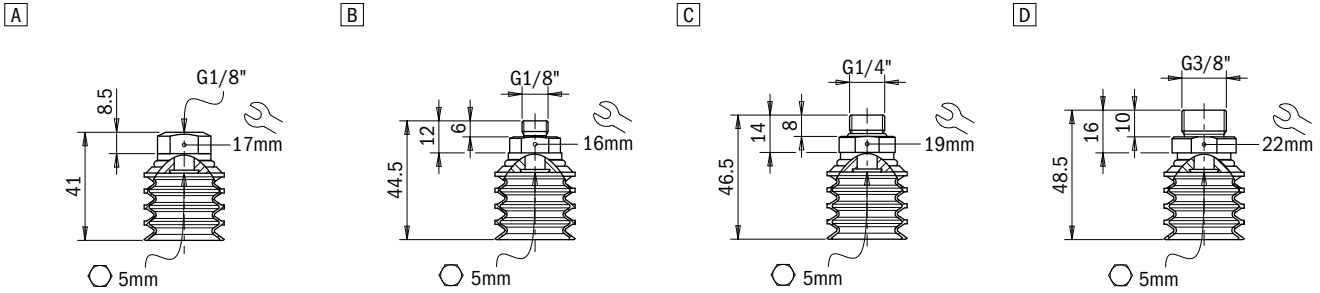

Identification codes			
Drawing	Alphanumeric code	Suction cups	Order code
A	VG.FP30F.50	VG.FP30 suction cup, FDA-compliant silicone, 50 Shore	2322076

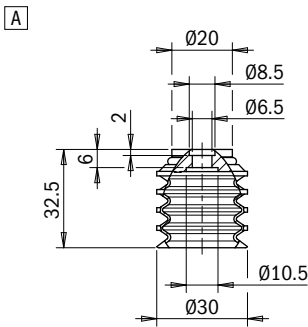

Identification codes			
Drawing	Alphanumeric code	Fittings	Order code
A	FT.G18F.18	G1/8" female fitting	1800019
B	FT.G18M.18	G1/8" male fitting	1800018
C	FT.G14M.18	G1/4" male fitting	1800014
D	FT.G38M.18	G3/8" male fitting	1800038

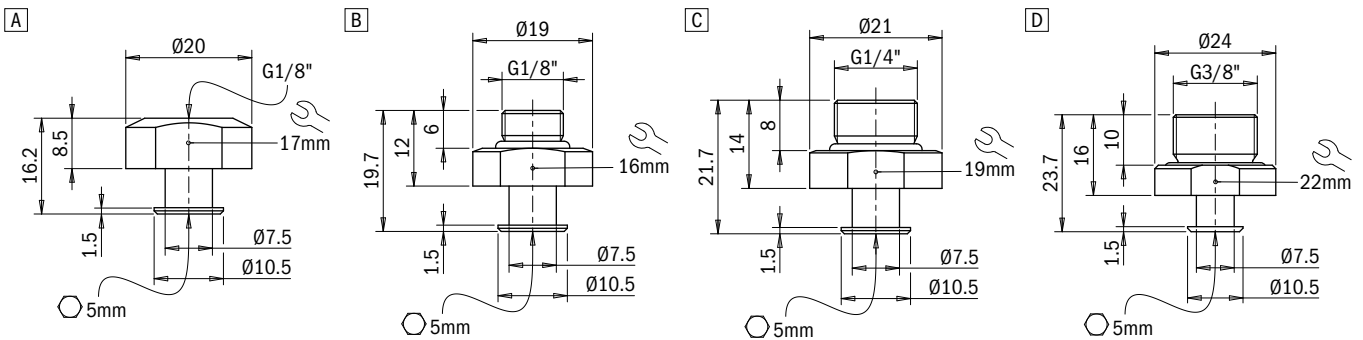

Identification codes		
Alphanumeric code	Disc	Order code
AC.DF30	Perforated disc for thin films, diameter 30 mm	2321781

Suction cups / FDA-compliant silicone

VG.FP40F multi-bellows suction cups in FDA-compliant silicone

- The silicone is FDA-compliant and therefore suitable for handling unpackaged food
- Suitable for level compensation
- High vertical movement, useful for separating thin parts
- It can be equipped with a perforated disc to increase stability and to allow the handling of thin films



Application example



Technical data

Material	Lifting force [N] perpendicular to the surface, at various vacuum levels			Lifting force [N] parallel to the surface, at various vacuum levels			Volume [cm ³]	Min curve radius [mm]	Max vertical movement [mm]	Suction cup weight [g]
	-20 kPa	-60 kPa	-90 kPa	-20 kPa	-60 kPa	-90 kPa				
SIL FDA 50	10.8	31.5	–	–	–	–	27	11	33	10

Technical features

Material	Color	Hardness	Temperature range
Silicone, FDA SIL	Transparent	50 Shore	-94 - +392 °F

Identification codes			
Drawing	Alphanumeric code	Suction cups with fitting	Order code
A	VG.FP40F.50.G18F	VG.FP40 suction cup, FDA-compliant silicone, 50 Shore, G1/8" female	2322080
B	VG.FP40F.50.G18M	VG.FP40 suction cup, FDA-compliant silicone, 50 Shore, G1/8" male	2322082
C	VG.FP40F.50.G14M	VG.FP40 suction cup, FDA-compliant silicone, 50 Shore, G1/4" male	2322083
D	VG.FP40F.50.G38M	VG.FP40 suction cup, FDA-compliant silicone, 50 Shore, G3/8" male	2322084

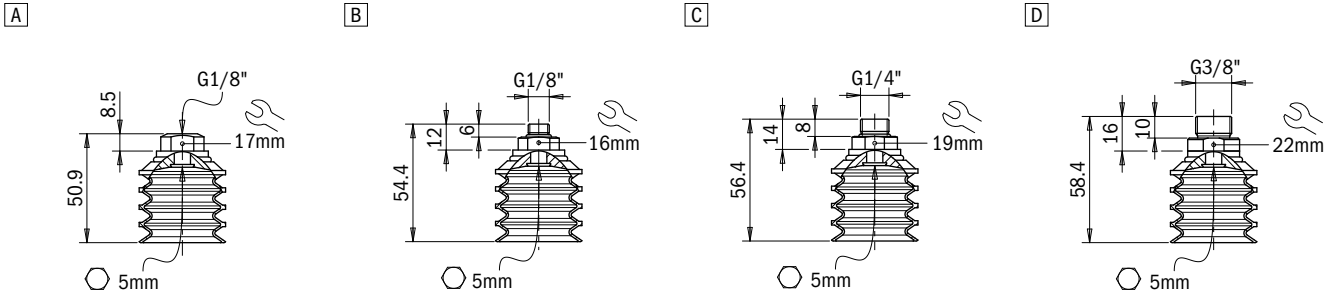

Identification codes			
Drawing	Alphanumeric code	Suction cups	Order code
A	VG.FP40F.50	VG.FP40 suction cup, FDA-compliant silicone, 50 Shore	2322081

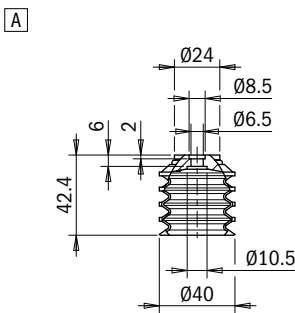

Click for Pricing & Add to Cart



Identification codes			
Drawing	Alphanumeric code	Fittings	Order code
A	FT.G18F.18	G1/8" female fitting	1800019
B	FT.G18M.18	G1/8" male fitting	1800018
C	FT.G14M.18	G1/4" male fitting	1800014
D	FT.G38M.18	G3/8" male fitting	1800038

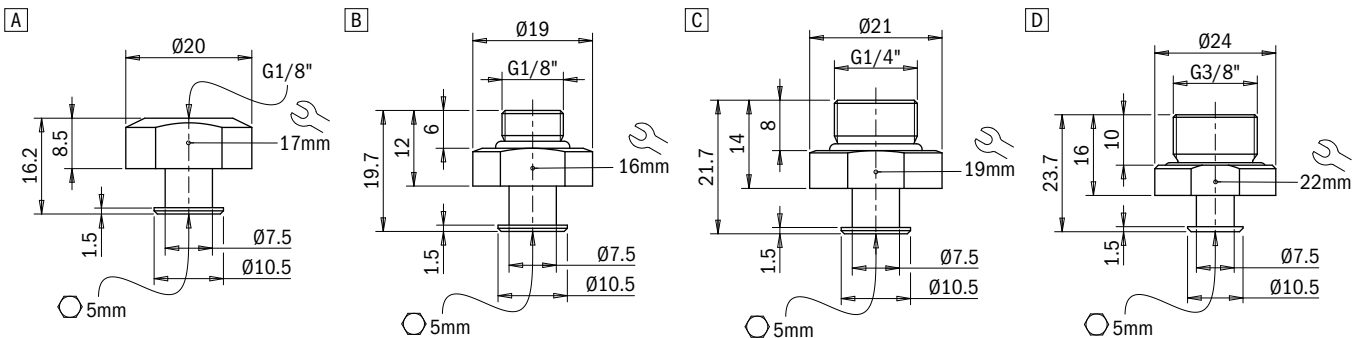

Identification codes		
Alphanumeric code	Disc	Order code
AC.DF40	Perforated disc for thin films, diameter 40 mm	2321755

Suction cups / FDA-compliant silicone

VG.F026F flat suction cups in FDA-compliant silicone with reinforcements and thin lip

- Suitable for opening bags and handling thin and delicate objects such as sheets and film
- The internal texture and the thin lip prevent damage to the handled object while maintaining its flatness
- Suction cups in FDA-approved transparent silicone

Application example

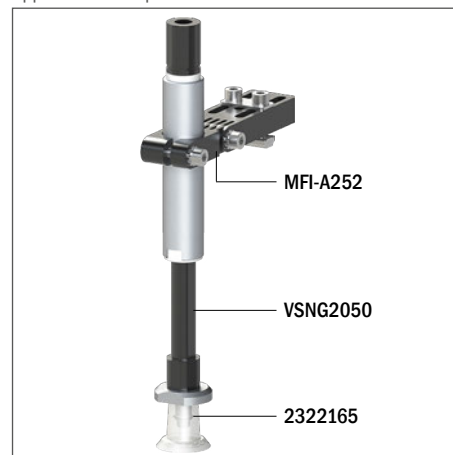

Technical data										
Material	Lifting force [N] perpendicular to the surface, at various vacuum levels			Lifting force [N] parallel to the surface, at various vacuum levels			Volume [cm ³]	Min curve radius [mm]	Max vertical movement [mm]	Suction cup weight [g]
	-20 kPa	-60 kPa	-90 kPa	-20 kPa	-60 kPa	-90 kPa				
SIL 50 FDA	10	25.1	30	9	20	25	1.6	25	1.5	4

Technical features			
Material	Color	Hardness	Temperature range
Silicone, FDA SIL	Transparent	50 Shore	-94 - +392 °F

Identification codes			
Drawing	Alphanumeric code	Suction cups with fitting	Order code
A	VG.FO26F.50.G18M	VG.FO26 suction cup, FDA-compliant silicone, 50 Shore, G1/8" male	2322165
B	VG.FO26F.50.G14M	VG.FO26 suction cup, FDA-compliant silicone, 50 Shore, G1/4" male	2322167

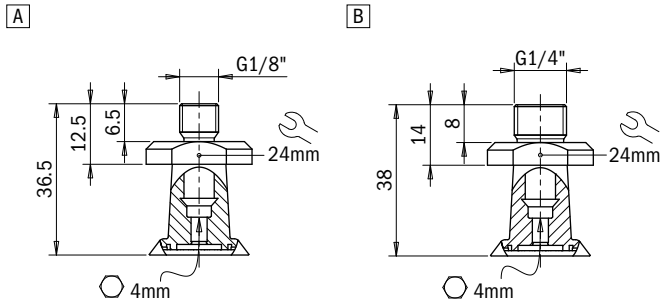

Identification codes			
Drawing	Alphanumeric code	Suction cups	Order code
A	VG.FO26F.50	VG.FO26 suction cup, FDA-compliant silicone, 50 Shore	2322166

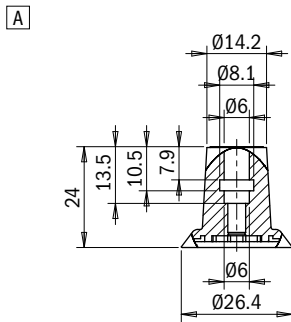

Identification codes			
Drawing	Alphanumeric code	Fittings	Order code
A	FT.G18M.30	G1/8" male fitting	3000018
B	FT.G14M.30	G1/4" male fitting	3000014

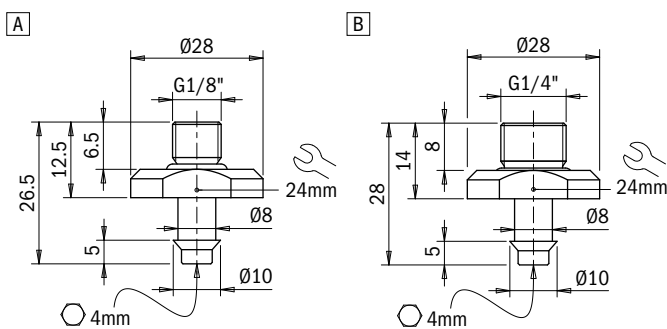

Suction cups / FDA-compliant silicone

VG.F033F flat suction cups in FDA-compliant silicone with reinforcements and thin lip

- Suitable for opening bags and handling thin and delicate objects such as sheets and film
- The internal texture and the thin lip prevent damage to the handled object while maintaining its flatness
- Suction cups in FDA-approved transparent silicone

Application example

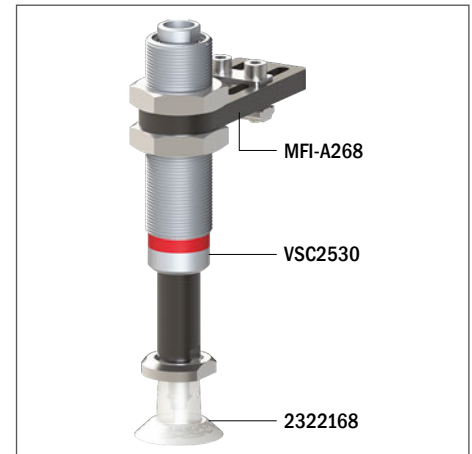

Technical data

Material	Lifting force [N] perpendicular to the surface, at various vacuum levels			Lifting force [N] parallel to the surface, at various vacuum levels			Volume [cm ³]	Min curve radius [mm]	Max vertical movement [mm]	Suction cup weight [g]
	-20 kPa	-60 kPa	-90 kPa	-20 kPa	-60 kPa	-90 kPa				
SIL 50 FDA	16.2	38.3	49.2	13	30	39	2.1	35	1.5	5

Technical features

Material	Color	Hardness	Temperature range
Silicone, FDA SIL	Transparent	50 Shore	-94 - +392 °F

Identification codes			
Drawing	Alphanumeric code	Suction cups with fitting	Order code
A	VG.F033F.50.G14M	VG.F033 suction cup, FDA-compliant silicone, 50 Shore, G1/4" male	2322168
B	VG.F033F.50.G38M	VG.F033 suction cup, FDA-compliant silicone, 50 Shore, G3/8" male	2322170

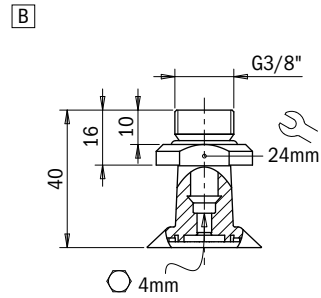
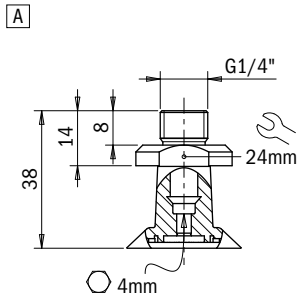

Identification codes			
Drawing	Alphanumeric code	Suction cups	Order code
A	VG.F033F.50	VG.F033 suction cup, FDA-compliant silicone, 50 Shore	2322169

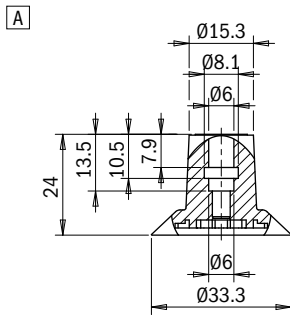

Identification codes			
Drawing	Alphanumeric code	Fittings	Order code
A	FT.G14M.30	G1/4" male fitting	3000014
B	FT.G38M.30	G3/8" male fitting	3000038

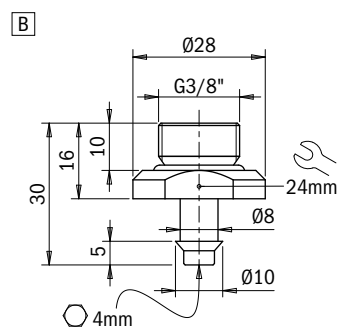
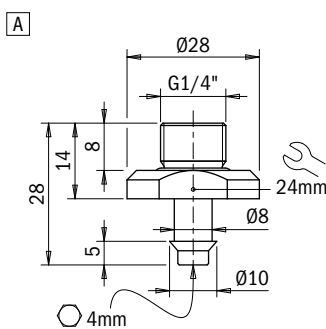

Suction cups / Detectable FDA-compliant silicone

VG.BDT40 multi-bellows suction cups in detectable FDA-compliant silicone

- Ideal for handling food products
- Detectable FDA-compliant silicone compliant with FDA 21 CFR 177.2600 standards
- Available with separable, acid-resistant, food-grade stainless steel fitting
- Easy to clean thanks to the hygienic design with no cavities where food dust or dirt might build up
- Available with clips for connection to demoulders in the bakery sector

NEW

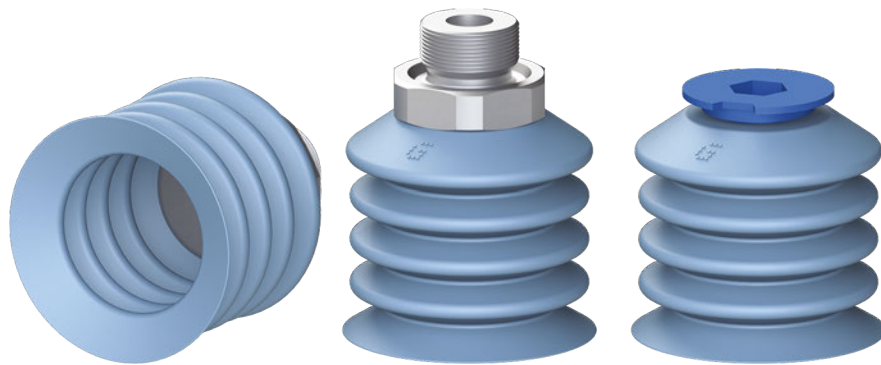

Application example

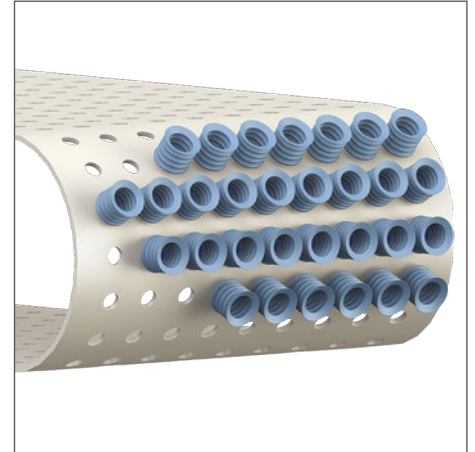

Technical data

Material	Lifting force [N] perpendicular to the surface, at various vacuum levels			Lifting force [N] parallel to the surface, at various vacuum levels			Volume [cm ³]	Min curve radius [mm]	Max vertical movement [mm]	Suction cup weight [g]
	-20 kPa	-60 kPa	-90 kPa	-20 kPa	-60 kPa	-90 kPa				
SIL40 FDA RIL	14.3	23.5	–	4.6	19.4	–	29.0	15.9	28.0	8.2

Technical features

Material	Color	Hardness	Temperature range
Detectable SIL FDA-compliant silicone	Blue	40 Shore	-40 - +392 °F

Identification codes			
Drawing	Alphanumeric code	Suction cups with fitting	Order code
A	VG.BDT40F40.G38M	VG.BDT40 suction cup, detectable FDA-compliant silicone, 40 Shore, G3/8" male, 25 mm hex, stainless steel	2322174
B	VG.BDT40F40.CF	VG.BDT40 suction cup, detectable FDA-compliant silicone, 40 Shore, fixing clip, 9 mm hex	2322176

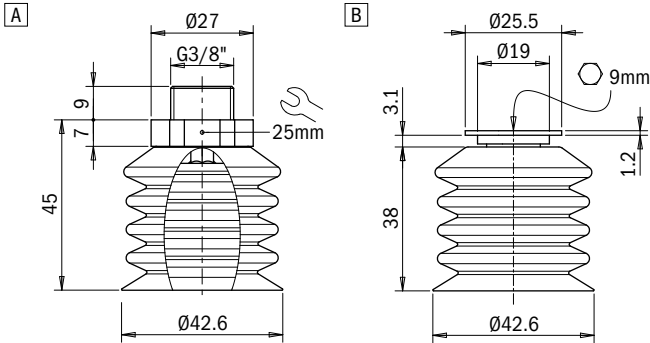

Identification codes			
Drawing	Alphanumeric code	Suction cups	Order code
A	VG.BDT40F40	VG.BDT40 suction cup, detectable FDA-compliant silicone, 40 Shore	2322175

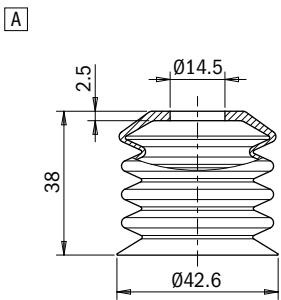

Identification codes			
Drawing	Alphanumeric code	Fittings	Order code
A	FT.G38M.E26.INOX	G3/8" male fitting, 25 mm hex, stainless steel	1500038
B	FT.9.CLIP	Fixing clip connection, 9 mm hex	1500009

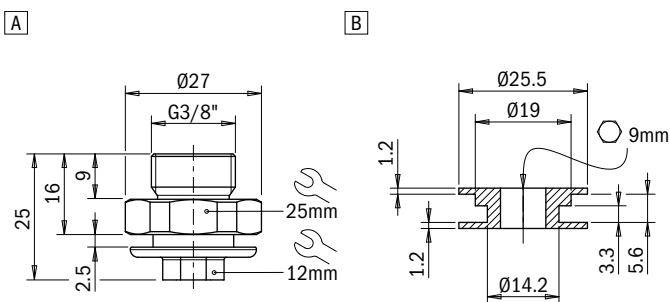

Foam material / EPDM – Silicone

Rings in EPDM foam and silicone foam

- Ideal to handle porous and corrugated surfaces
- High adaptability on rough wood panels and corrugated sheet metal
- EPDM: thickness 5 and 10 mm for diameters 20, 30, 40 and 50 mm
- Silicone: 2 mm thickness for diameters of 15, 20, 30, 40 and 50 mm
- The silicone version is mark-free

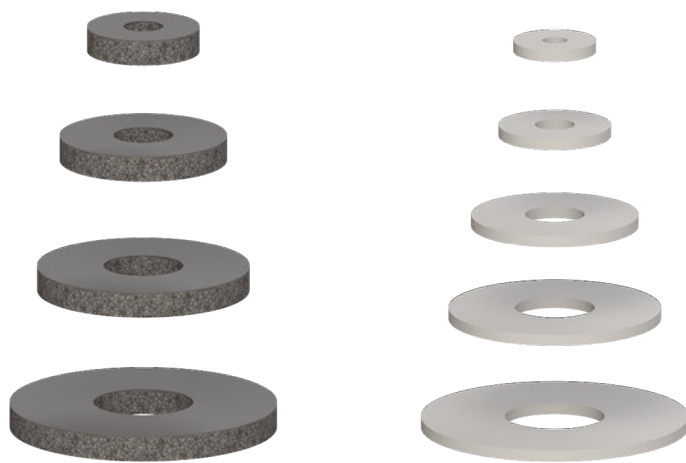

Application example



Technical features

Material	Color	Temperature range
EPDM	Black	-40 - +275 °F
SIL	White	-67 - +392 °F

Identification codes			
Drawing	Alphanumeric code	Rings in EPDM foam	Order code
A	VG.FOAM22-5	Ring in EPDM foam for suction cups, diameter 20 mm, thickness 5 mm	0000001
B	VG.FOAM22-10	Ring in EPDM foam for suction cups, diameter 20 mm, thickness 10 mm	0000002
C	VG.FOAM33-5	Ring in EPDM foam for suction cups, diameter 30 mm, thickness 5 mm	0000003
D	VG.FOAM33-10	Ring in EPDM foam for suction cups, diameter 30 mm, thickness 10 mm	0000004
E	VG.FOAM42-5	Ring in EPDM foam for suction cups, diameter 40 mm, thickness 5 mm	0000005
F	VG.FOAM42-10	Ring in EPDM foam for suction cups, diameter 40 mm, thickness 10 mm	0000006
G	VG.FOAM53-5	Ring in EPDM foam for suction cups, diameter 50 mm, thickness 5 mm	0000007
H	VG.FOAM53-10	Ring in EPDM foam for suction cups, diameter 50 mm, thickness 10 mm	0000008

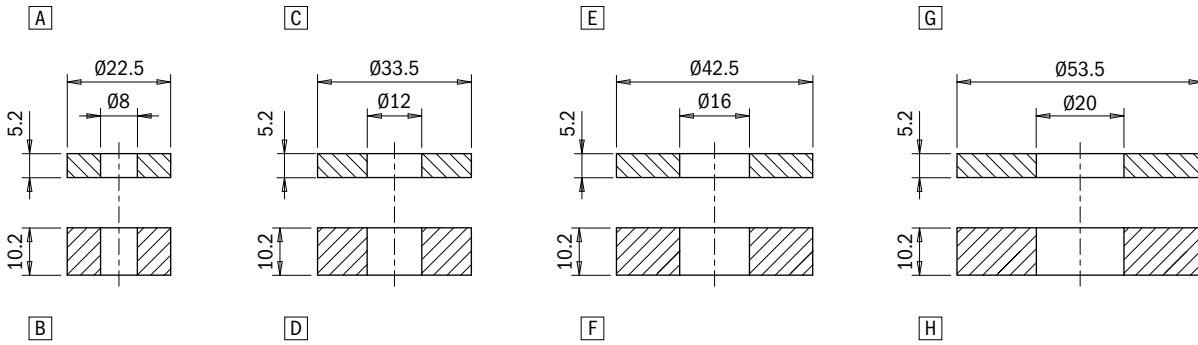

Identification codes			
Drawing	Alphanumeric code	Rings in silicone foam	Order code
A	VG.FOAM-SI-16-2	Silicone foam for suction cups, diameter 15 mm, thickness 2 mm	0000009
B	VG.FOAM-SI-22-2	Silicone foam for suction cups, diameter 20 mm, thickness 2 mm	0000010
C	VG.FOAM-SI-32-2	Silicone foam for suction cups, diameter 30 mm, thickness 2 mm	0000011
D	VG.FOAM-SI-42-2	Silicone foam for suction cups, diameter 40 mm, thickness 2 mm	0000012
E	VG.FOAM-SI-53-2	Silicone foam for suction cups, diameter 50 mm, thickness 2 mm	0000013

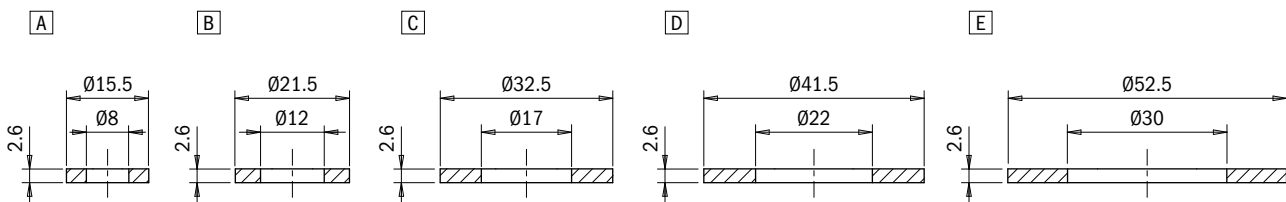

Introduction

Vacuum theory

Suction cups

Vacuum pumps

Customised solutions

Suspensions

System accessories

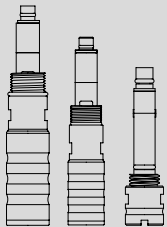
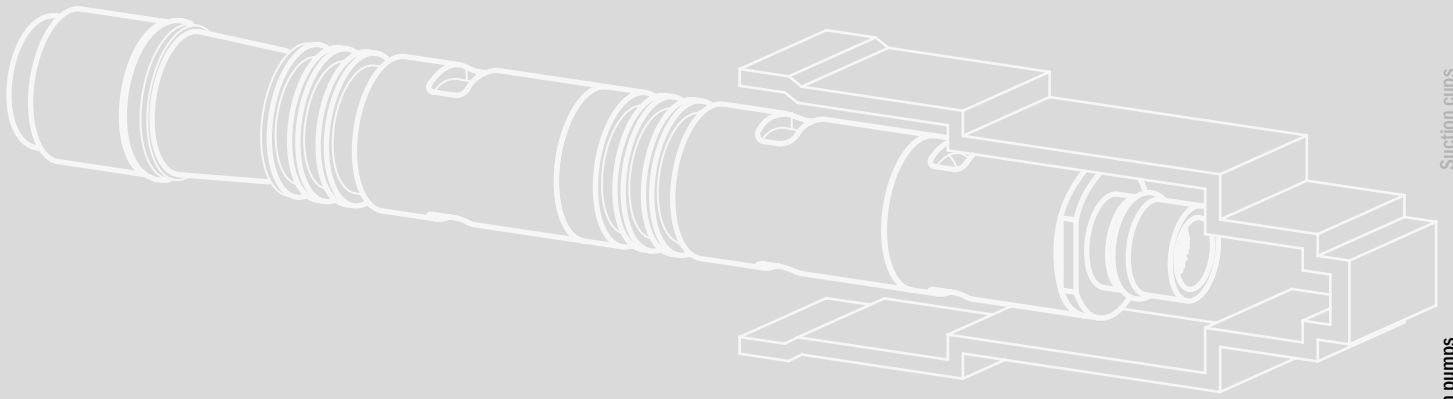

MULTISTAGE CARTRIDGES FOR INTEGRATION

Introduction

Vacuum theory

Suction cups

Vacuum pumps

Customised solutions

Suspensions

System accessories

EJ CARTRIDGE SELECTION GUIDE

Gimatic's EJ multistage cartridges are available in 3 sizes:

- EJ-SMALL
- EJ-MEDIUM
- EJ-LARGE

Each multi-stage cartridge has different characteristics depending on the model.

Size	Model	Vacuum level	Low feed pressure	High vacuum level	High suction flow rate	High initial flow rate
SMALL	EJ-SMALL-LP-2	-82 kPa	X			
	EJ-SMALL-HF-2	-78 kPa			X	
	EJ-SMALL-HV-2	-92 kPa		X		
MEDIUM	EJ-MEDIUM-LP-2	-90 kPa	X			
	EJ-MEDIUM-LP-3	-90 kPa	X			X
	EJ-MEDIUM-HF-2	-73 kPa			X	
	EJ-MEDIUM-HF-3	-73 kPa			X	X
	EJ-MEDIUM-HV-2	-94 kPa		X		
	EJ-MEDIUM-HV-3	-94 kPa		X		X
LARGE	EJ-LARGE-LP-2	-90 kPa	X			
	EJ-LARGE-LP-3	-90 kPa	X			X
	EJ-LARGE-HF-2	-73 kPa			X	
	EJ-LARGE-HF-3	-73 kPa			X	X
	EJ-LARGE-HV-2	-94 kPa		X		
	EJ-LARGE-HV-3	-94 kPa		X		X



[Click for Quick Navigation](#)



CHARACTERISTICS

EJ-LP (LOW PRESSURE)

The EJ-LP cartridges can reach a high vacuum level with low feed pressure. They are recommended both in applications such as the handling of glass panels or metal sheets and in all sealed circuits, where a good flow rate at a high vacuum level is required.

EJ-HF (HIGH FLOW)

EJ-HF cartridges evacuate large volumes of air. They are therefore suitable for handling porous objects such as cardboard, wood and materials with uneven surfaces. Ideal where it is necessary to evacuate large volumes of air to keep the circuit at a certain level of vacuum during the production cycle, compensating for any leaks.

EJ-HV (HIGH VACUUM)

EJ-HV cartridges are ideal for sealed applications such as glass panel handling, metal sheet handling and thermoforming applications.

MATERIALS



- PA= Polyamide, Nylon®
- Al= Aluminium
- NBR= Nitrile
- SS= Stainless steel

RECOMMENDED TUBE DIMENSIONS (internal diameter)



Connections	EJ-SMALL cartridge	EJ-MEDIUM cartridge	EJ-LARGE cartridge
Compressed air	≥ 2.5 mm	≥ 4 mm	≥6 mm
Vacuum	≥ 2.5 mm	≥8 mm	≥12 mm
Exhaust	≥ 8 mm	≥10 mm	≥15 mm

* Applies to pipes up to 1.5 m long

GIMATIC CARTRIDGE EJECTORS FOR INTEGRATED SOLUTIONS

Gimatic's multi-stage cartridge ejectors create vacuum using compressed air. Our vacuum pumps are compact in size, efficient and reliable, ideal to meet the integration requirements of our customers. They allow the development of flexible, modular and lightweight vacuum systems.

Modularity and flexibility enable to meet market changes, with reduced costs and increased productivity. Gimatic develops and manufactures products with high quality standards, which allow to improve production processes with reduced energy consumption.



OPERATING PRINCIPLE OF GIMATIC'S EJ CARTRIDGES

When compressed air passes through the nozzles, the air is sucked by means of the compressed air flow. The suction is generated at each stage, resulting in the generation of vacuum.

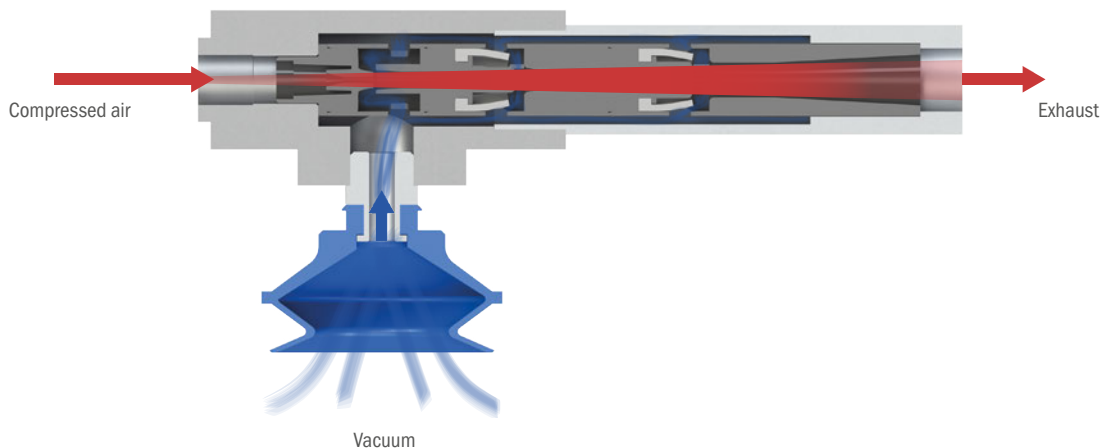



LOW ENERGY CONSUMPTION AND REDUCED DOWNTIME

Integrating the EJ cartridges right into the machines enables to generate vacuum near the point of use, which makes the most of the energy employed and increases the operating speed, eliminating pressure drops and possible inefficiencies of the vacuum circuit.



INTEGRATION - ADVANTAGES

Bringing the pump closer to the point of use guarantees:

- Greater Efficiency
- Reduced energy consumption
- Better monitoring of the system
- Reduced gripping and release times

HOW TO INTEGRATE THE EJ MULTISTAGE CARTRIDGES

Simply make a hole and insert the suction cartridge to obtain a completely integrated vacuum system.

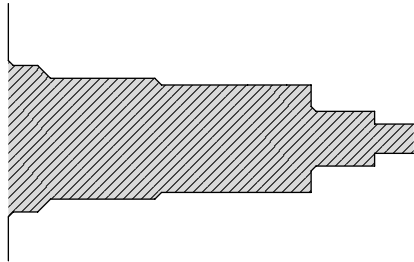

EXAMPLES OF INTEGRATION



EJ-SMALL cartridge in-line integration



Decentralised EOAT with rapid prototyping



Integration of EJ-MEDIUM cartridges on EOAT in rapid prototyping - Pick-and-Place application

EJ-SMALL cartridges for integration

EJ-SMALL-LP-2

- Two-stage EJ-SMALL-LP-2 cartridge with extremely compact dimensions
- Can be integrated near the gripping point, lightweight
- Ideal for high speed Pick & Place applications
- Suitable for handling sealed objects
- Maximum vacuum level (-82 kPa)
- Available in the cartridge-only or cartridge with holder versions

Introduction

Vacuum theory

Suction cups

Vacuum pumps

Customised solutions

Suspensions

System accessories



Technical features

Max feed pressure	0.7 MPa
Temperature range	+14 - +176 °F
Weight	0.6 ÷ 1.9 g

Suction flow rate

Feed pressure [MPa]	Air consumption [l/s]	Suction flow rate [l/s] at different vacuum levels [kPa]								Max vacuum [kPa]
		0	-10	-20	-30	-40	-50	-60	-70	
0.12	0.11	0.18	0.08	0.05	0.038	0.023	–	–	–	-50
0.15	0.13	0.20	0.09	0.06	0.05	0.04	0.02	–	–	-65
0.22	0.17	0.25	0.18	0.08	0.05	0.04	0.025	0.018	0.0053	-82

Evacuation time

Feed pressure [MPa]	Air consumption [l/s]	Evacuation time [s/l] to reach different vacuum levels [kPa]								Max vacuum [kPa]
		-10	-20	-30	-40	-50	-60	-70	-80	
0.12	0.11	0.77	2.31	4.58	7.9	16.6	–	–	–	-50
0.15	0.13	0.69	2.02	3.84	6.1	9.4	19.4	–	–	-65
0.22	0.17	0.47	1.23	2.77	5	8.07	12.7	21.3	59.01	-82

Identification codes

Drawing	Alphanumeric code	Description	Order code
A	EJ-S-LP-2	EJ-SMALL-LP-2 without holder	3300001
B	EJ-S-LP-2-H	EJ-SMALL-LP-2 with holder	3300002



Click for Pricing & Add to Cart

A

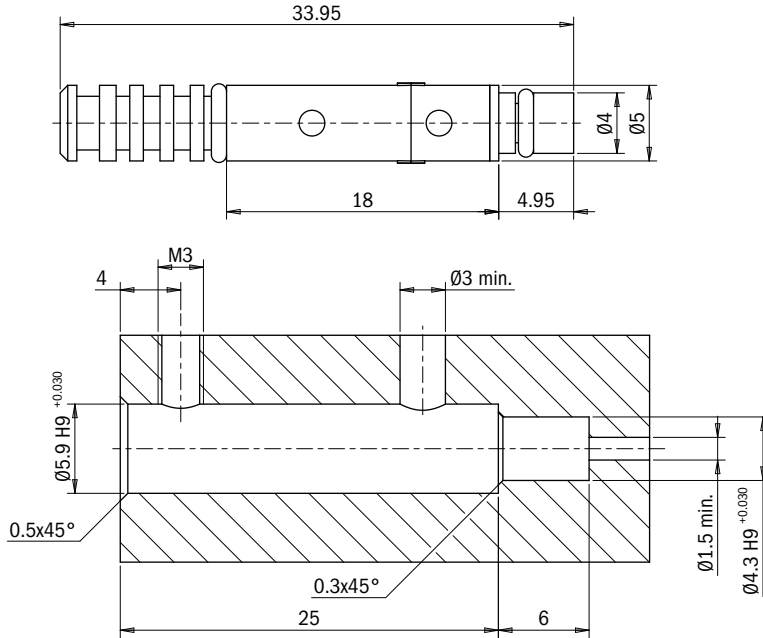

B

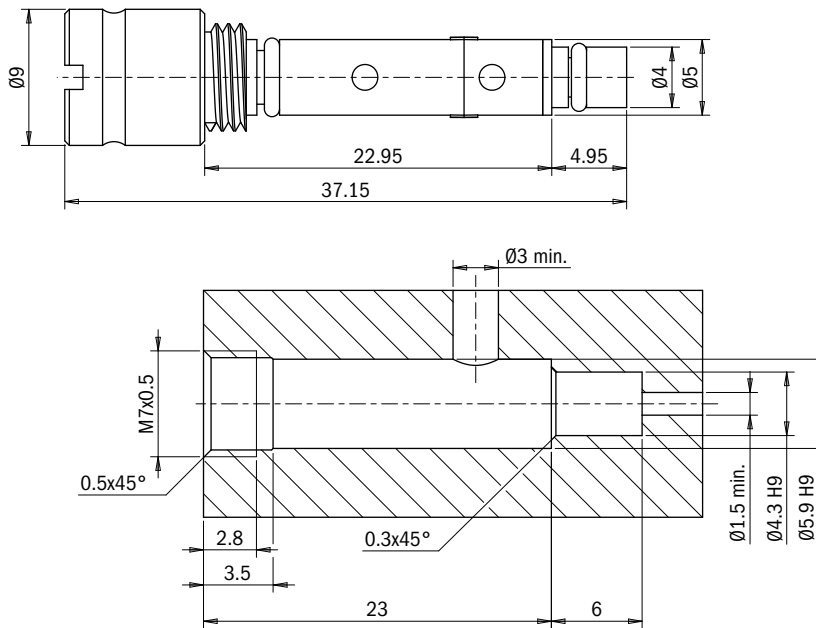

Introduction

Vacuum theory

Suction cups

Vacuum pumps

Customised solutions

Suspensions

System accessories

EJ-SMALL cartridges for integration

EJ-SMALL-HF-2

- Two-stage EJ-SMALL-HF-2 cartridge with extremely compact dimensions
- Can be integrated near the gripping point, lightweight
- Ideal for high speed Pick & Place applications
- Suitable for handling porous objects
- Maximum vacuum level (-78 kPa)
- Available in the cartridge-only or cartridge with holder versions

Introduction

Vacuum theory

Suction cups

Vacuum pumps

Customised solutions

Suspensions

System accessories



Technical features

Max feed pressure	0.7 MPa
Temperature range	+14 - +176 °F
Weight	0.6 ÷ 1.9 g

Suction flow rate

Feed pressure [MPa]	Air consumption [NI/s]	Suction flow rate [NI/s] at different vacuum levels [kPa]								Max vacuum [kPa]
		0	-10	-20	-30	-40	-50	-60	-70	
0.4	0.12	0.26	0.13	0.08	0.07	0.06	0.04	0.02	—	-65
0.5	0.13	0.28	0.16	0.09	0.08	0.05	0.04	0.02	—	-72
0.6	0.15	0.29	0.18	0.10	0.08	0.05	0.041	0.033	0.025	-78

Evacuation time

Feed pressure [MPa]	Air consumption [NI/s]	Evacuation time [s/l] to reach different vacuum levels [kPa]							Max vacuum [kPa]
		-10	-20	-30	-40	-50	-60	-70	
0.4	0.12	0.51	1.47	2.8	4.3	6.3	9.7	—	-65
0.5	0.13	0.45	1.25	2.43	4.0	6.2	9.5	—	-72
0.6	0.15	0.43	1.14	2.25	3.8	6.0	8.7	12.1	-78

Identification codes

Drawing	Alphanumeric code	Description	Order code
A	EJ-S-HF-2	EJ-SMALL-HF-2 without holder	3300003
B	EJ-S-HF-2-H	EJ-SMALL-HF-2 with holder	3300004

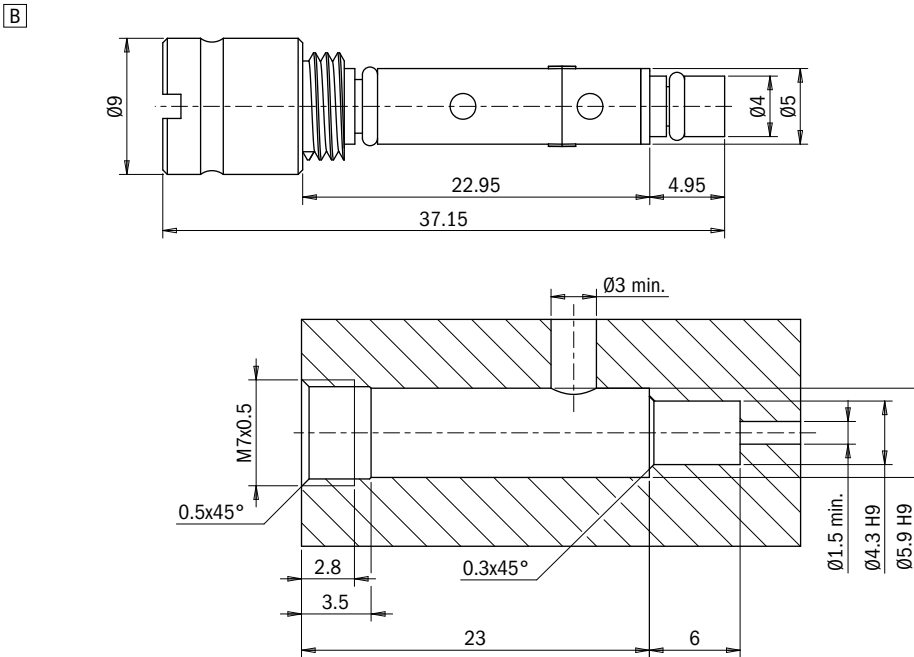
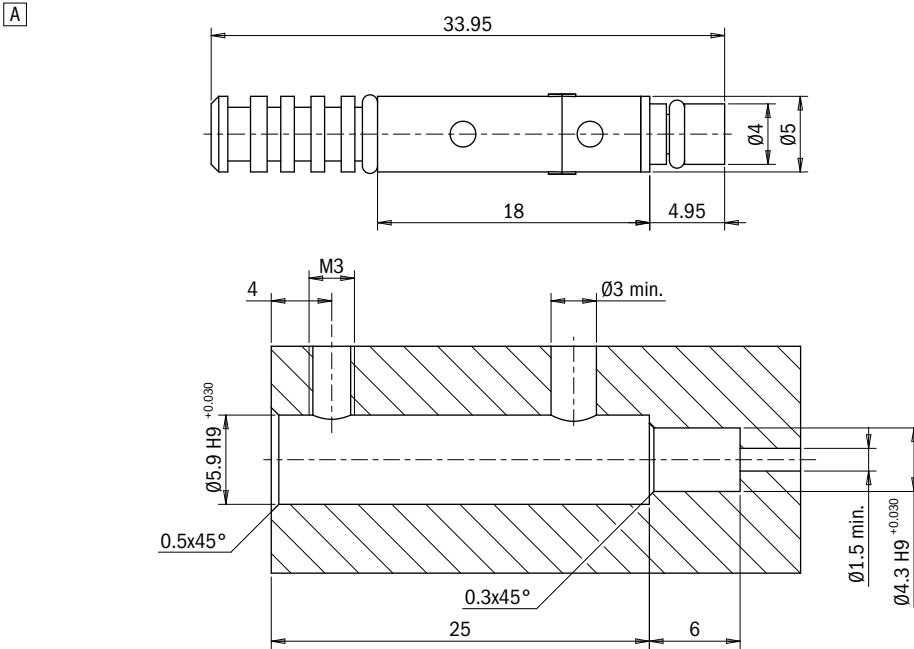

EJ-SMALL cartridges for integration

EJ-SMALL-HV-2

- Two-stage EJ-SMALL-HV-2 cartridge with extremely compact dimensions
- Can be integrated near the gripping point, lightweight
- Ideal for high speed Pick & Place applications
- Fast response times at high vacuum levels
- Suitable for handling sealed objects
- Maximum vacuum level (-92 kPa)
- Available in the cartridge-only or cartridge with holder versions

Introduction

Vacuum theory

Suction cups

Vacuum pumps

Customised solutions

Suspensions

System accessories



Technical features

Max feed pressure	0.7 MPa
Temperature range	+14 - +176 °F
Weight	0.6 ÷ 1.9 g

Suction flow rate

Feed pressure [MPa]	Air consumption [l/s]	Suction flow rate [l/s] at different vacuum levels [kPa]									Max vacuum [kPa]
		0	-10	-20	-30	-40	-50	-60	-70	-80	
0.5	0.13	0.22	0.16	0.10	0.06	0.05	0.04	0.02	0.01	0.010	-92
0.55	0.14	0.23	0.17	0.10	0.05	0.04	0.03	0.02	0.01	0.004	-91
0.6	0.15	0.23	0.16	0.08	0.05	0.04	0.03	0.02	0.01	0.005	-90

Evacuation time

Feed pressure [MPa]	Air consumption [l/s]	Evacuation time [s/l] to reach different vacuum levels [kPa]								Max vacuum [kPa]
		-10	-20	-30	-40	-50	-60	-70	-80	
0.5	0.13	0.53	1.30	2.55	4.4	6.6	9.9	16.6	36.6	-92
0.55	0.14	0.50	1.24	2.57	4.8	7.7	11.7	18.3	32.6	-91
0.6	0.15	0.51	1.35	2.88	5.1	8.0	12.1	18.6	32.1	-90

Identification codes

Drawing	Alphanumeric code	Description	Order code
A	EJ-S-HV-2	EJ-SMALL-HV-2 without holder	3300005
B	EJ-S-HV-2-H	EJ-SMALL-HV-2 with holder	3300006

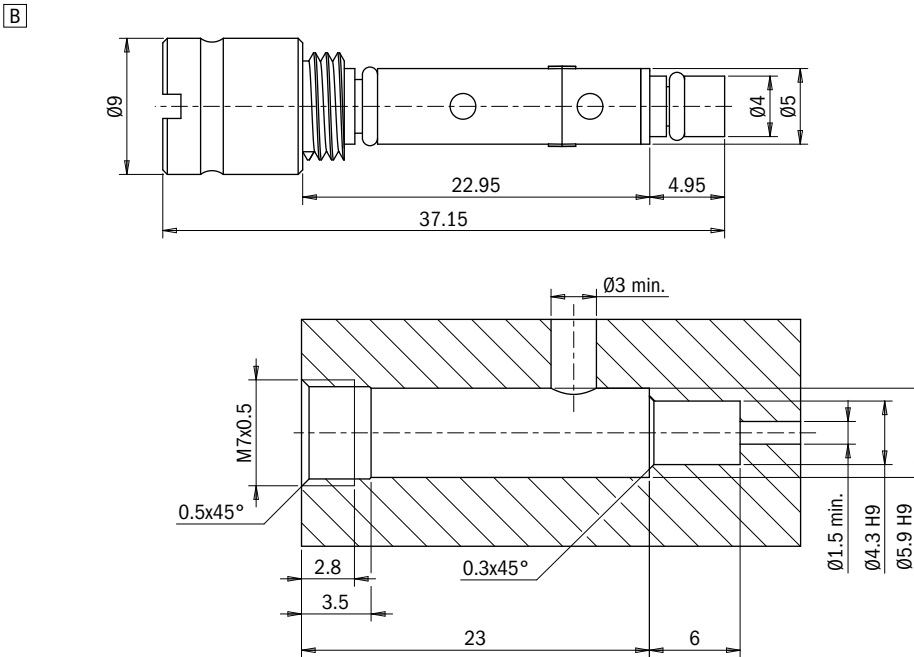
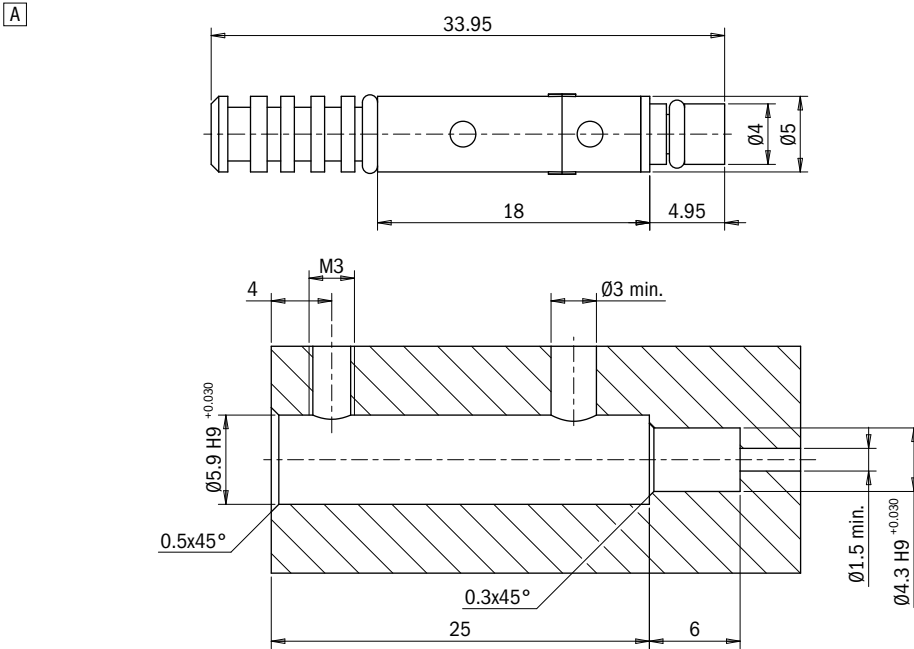

EJ-MEDIUM cartridges for integration

EJ-MEDIUM-LP-2

- Two-stage EJ-MEDIUM-LP-2 cartridge with compact dimensions
- Can be integrated near the gripping point, lightweight
- Suitable and reliable even in the case of fluctuations in feed pressure
- Ideal for handling sealed objects
- Maximum vacuum level (-90 kPa)
- Available in the cartridge-only or cartridge with holder and integrated silencer versions



Technical features

Max feed pressure	0.7 MPa
Temperature range	+14 - +176 °F
Weight	2.4 ± 15 g

Suction flow rate

Feed pressure [MPa]	Air consumption [l/s]	Suction flow rate [l/s] at different vacuum levels [kPa]										Max vacuum [kPa]
		0	-10	-20	-30	-40	-50	-60	-70	-80		
0.2	0.33	0.57	0.41	0.23	0.12	0.07	—	—	—	—	-55	
0.35	0.48	0.68	0.62	0.45	0.26	0.18	0.13	0.1	0.06	0.03	-90	
0.4	0.55	0.67	0.61	0.53	0.38	0.23	0.12	0.09	0.06	0.02	-89	

Evacuation time

Feed pressure [MPa]	Air consumption [l/s]	Evacuation time [s/l] to reach different vacuum levels [kPa]									Max vacuum [kPa]
		-10	-20	-30	-40	-50	-60	-70	-80		
0.2	0.33	0.21	0.52	1.09	2.1	—	—	—	—	-55	
0.35	0.48	0.16	0.32	0.6	1.1	1.7	2.6	3.8	6.1	-90	
0.4	0.55	0.17	0.33	0.55	0.9	1.5	2.4	3.7	7.1	-89	

Identification codes

Drawing	Alphanumeric code	Description	Order code
A	EJ-M-LP-2	EJ-MEDIUM-LP-2 without holder	3300007
B	EJ-M-LP-2-HS	EJ-MEDIUM-LP-2 with holder and integrated silencer	3300008
C	EJ-M-LP-2-NR	EJ-MEDIUM-LP-2 with non-return valve	3300009
D	EJ-M-LP-2-NR-HS	EJ-MEDIUM-LP-2 with holder, integrated silencer and non-return valve	3300010
E	EJ-M-LP-2-H	EJ-MEDIUM-LP-2 with holder	3300059

A C

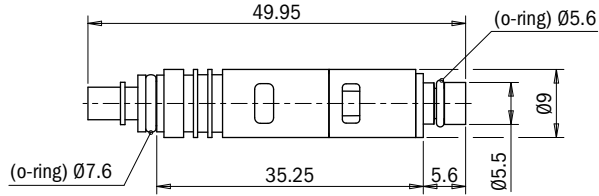

B D

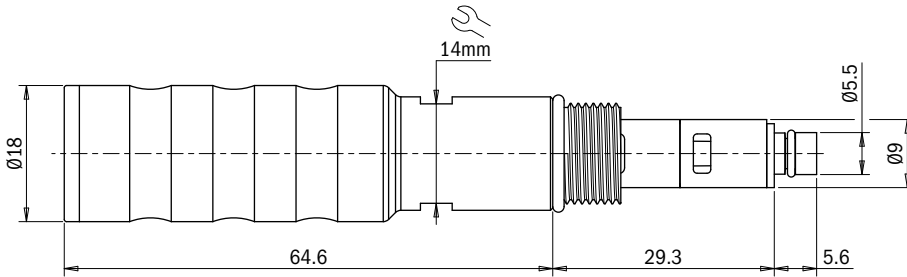

E

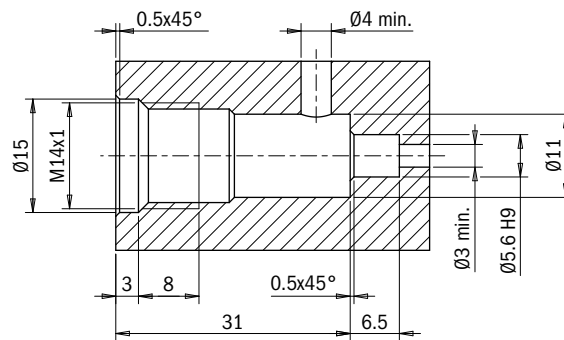
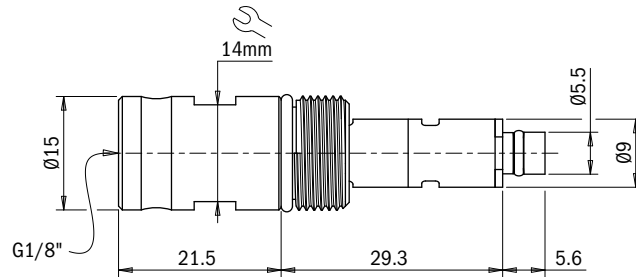

EJ-MEDIUM cartridges for integration

EJ-MEDIUM-LP-3

- Three-stage EJ-MEDIUM-LP-3 cartridge with compact dimensions
- High initial flow rate, reduces gripping time
- Can be integrated near the gripping point, lightweight
- Suitable and reliable even in the case of fluctuations in feed pressure
- Ideal for handling sealed objects
- Maximum vacuum level (-90 kPa)
- Available in the cartridge-only or cartridge with holder and integrated silencer versions



Technical features

Max feed pressure	0.7 MPa
Temperature range	+14 - +176 °F
Weight	4 ± 18.7 g

Suction flow rate

Feed pressure [MPa]	Air consumption [l/s]	Suction flow rate [l/s] at different vacuum levels [kPa]										Max vacuum [kPa]
		0	-10	-20	-30	-40	-50	-60	-70	-80		
0.2	0.33	0.9	0.41	0.23	0.12	0.07	—	—	—	—	-55	
0.35	0.48	1.6	0.73	0.45	0.26	0.18	0.14	0.10	0.06	0.03	-90	
0.4	0.55	1.5	0.71	0.53	0.38	0.24	0.12	0.09	0.06	0.02	-89	

Evacuation time

Feed pressure [MPa]	Air consumption [l/s]	Evacuation time [s/l] to reach different vacuum levels [kPa]									Max vacuum [kPa]
		-10	-20	-30	-40	-50	-60	-70	-80		
0.2	0.33	0.15	0.45	1.09	2.1	—	—	—	—	-55	
0.35	0.48	0.06	0.20	0.50	1.1	1.7	2.6	3.8	6.1	-90	
0.4	0.55	0.08	0.23	0.44	0.76	1.4	2.4	3.7	7.1	-89	

Identification codes

Drawing	Alphanumeric code	Description	Order code
A	EJ-M-LP-3	EJ-MEDIUM-LP-3 without holder	3300019
B	EJ-M-LP-3-HS	EJ-MEDIUM-LP-3 with holder and integrated silencer	3300020
C	EJ-M-LP-3-NR	EJ-MEDIUM-LP-3 with non-return valve	3300021
D	EJ-M-LP-3-NR-HS	EJ-MEDIUM-LP-3 with holder, integrated silencer and non-return valve	3300022
E	EJ-M-LP-3-H	EJ-MEDIUM-LP-3 with holder	3300062

A C

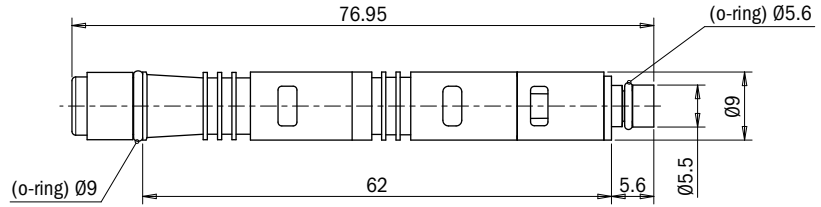

B D

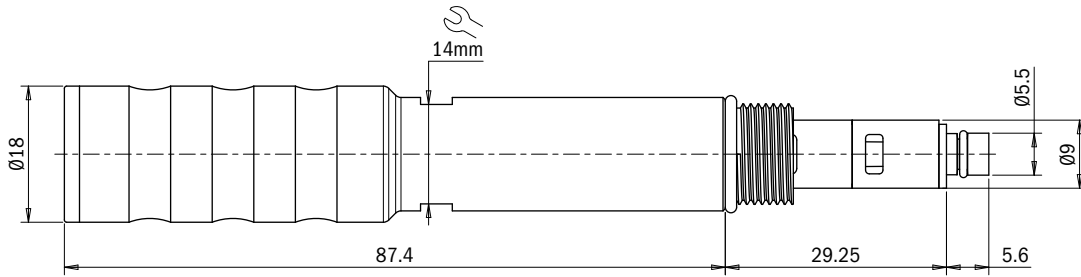

E

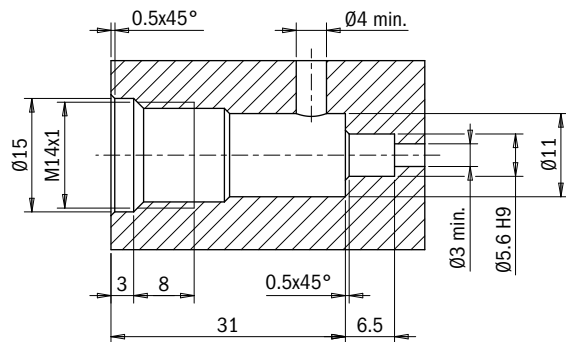
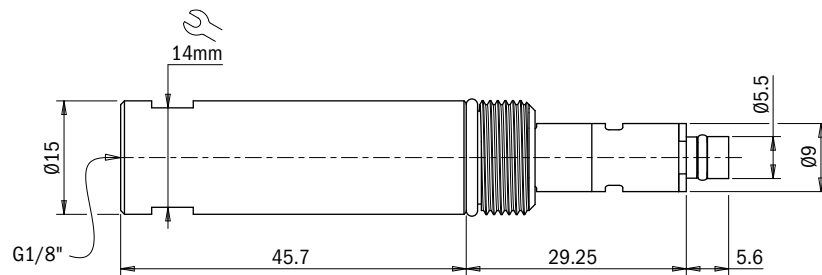

EJ-MEDIUM cartridges for integration

EJ-MEDIUM-HF-2

- Two-stage EJ-MEDIUM-HF-2 cartridge with compact dimensions
- Can be integrated near the gripping point, lightweight
- Suitable for handling objects with uneven or porous surfaces
- Maximum vacuum level (-73 kPa)
- Available in the cartridge-only or cartridge with holder and integrated silencer versions



Technical features

Max feed pressure	0.7 MPa
Temperature range	+14 - +176 °F
Weight	2.2 ± 15 g

Suction flow rate

Feed pressure [MPa]	Air consumption [NI/s]	Suction flow rate [NI/s] at different vacuum levels [kPa]								Max vacuum [kPa]
		0	-10	-20	-30	-40	-50	-60	-70	
0.4	0.32	0.70	0.54	0.33	0.26	0.20	0.14	—	—	-60
0.5	0.39	0.76	0.62	0.42	0.28	0.19	0.15	0.06	0.01	-69
0.6	0.43	0.78	0.68	0.52	0.31	0.21	0.15	0.10	0.08	-73

Evacuation time

Feed pressure [MPa]	Air consumption [NI/s]	Evacuation time [s/l] to reach different vacuum levels [kPa]							Max vacuum [kPa]
		-10	-20	-30	-40	-50	-60	-70	
0.4	0.32	0.16	0.39	0.72	1.1	1.9	3.6	—	-60
0.5	0.39	0.14	0.34	0.62	1	1.6	2.6	4.7	-69
0.6	0.43	0.13	0.30	0.54	0.9	1.5	2.3	3.2	-73

Identification codes

Drawing	Alphanumeric code	Description	Order code
A	EJ-M-HF-2	EJ-MEDIUM-HF-2 without holder	3300011
B	EJ-M-HF-2-HS	EJ-MEDIUM-HF-2 with holder and integrated silencer	3300012
C	EJ-M-HF-2-NR	EJ-MEDIUM-HF-2 with non-return valve	3300013
D	EJ-M-HF-2-NR-HS	EJ-MEDIUM-HF-2 with holder, integrated silencer and non-return valve	3300014
E	EJ-M-HF-2-H	EJ-MEDIUM-HF-2 with holder	3300058

A C

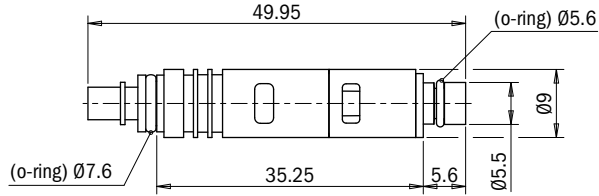

B D

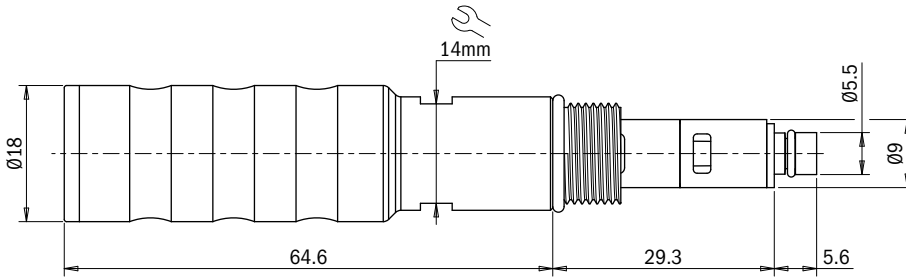

E

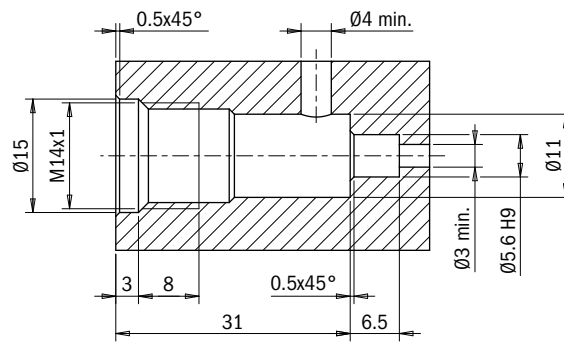
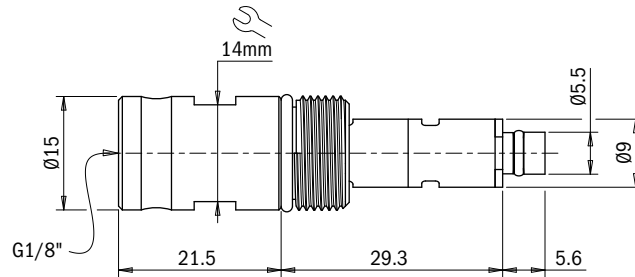

EJ-MEDIUM cartridges for integration

EJ-MEDIUM-HF-3

- Three-stage EJ-MEDIUM-HF-3 cartridge with compact dimensions
- High initial flow rate, reduces gripping time
- Suitable for handling objects with uneven or porous surfaces
- Can be integrated near the gripping point, lightweight
- Maximum vacuum level (-73 kPa)
- Available in the cartridge-only or cartridge with holder and integrated silencer versions



Technical features

Max feed pressure	0.7 MPa
Temperature range	+14 - +176 °F
Weight	4 ± 18.7 g

Suction flow rate

Feed pressure [MPa]	Air consumption [NI/s]	Suction flow rate [NI/s] at different vacuum levels [kPa]								Max vacuum [kPa]
		0	-10	-20	-30	-40	-50	-60	-70	
0.4	0.32	1	0.57	0.36	0.26	0.20	0.14	—	—	-60
0.5	0.39	1.22	0.64	0.46	0.28	0.19	0.15	0.06	0.01	-70
0.6	0.43	1.35	0.75	0.55	0.31	0.21	0.15	0.10	0.08	-73

Evacuation time

Feed pressure [MPa]	Air consumption [NI/s]	Evacuation time [s/l] to reach different vacuum levels [kPa]							Max vacuum [kPa]
		-10	-20	-30	-40	-50	-60	-70	
0.4	0.32	0.13	0.34	0.66	1.1	1.9	3.6	—	-60
0.5	0.39	0.11	0.29	0.55	0.9	1.5	2.3	4.6	-70
0.6	0.43	0.1	0.25	0.48	0.8	1.3	2.3	3.2	-73

Identification codes

Drawing	Alphanumeric code	Description	Order code
A	EJ-M-HF-3	EJ-MEDIUM-HF-3 without holder	3300023
B	EJ-M-HF-3-HS	EJ-MEDIUM-HF-3 with holder and integrated silencer	3300024
C	EJ-M-HF-3-NR	EJ-MEDIUM-HF-3 with non-return valve	3300025
D	EJ-M-HF-3-NR-HS	EJ-MEDIUM-HF-3 with holder, integrated silencer and non-return valve	3300026
E	EJ-M-HF-3-H	EJ-MEDIUM-HF-3 with holder	3300061



Click for Pricing & Add to Cart

A C

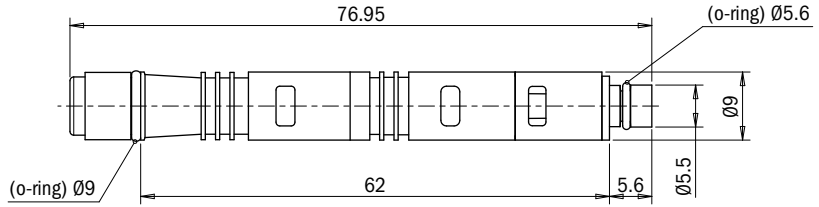

B D

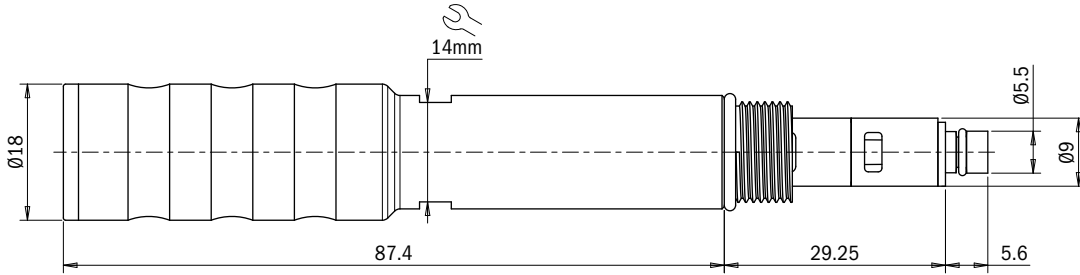

E

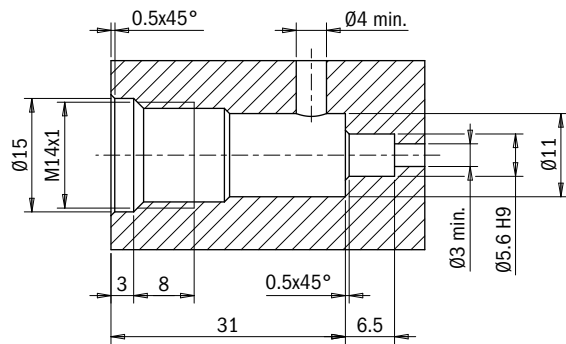
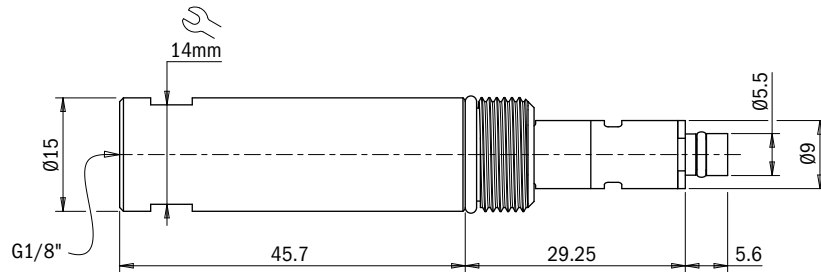

EJ-MEDIUM cartridges for integration

EJ-MEDIUM-HV-2

- Two-stage EJ-MEDIUM-HV-2 cartridge with compact dimensions
- Can be integrated near the gripping point, lightweight
- Suitable for handling sealed objects
- Fast response times at high vacuum levels
- Maximum vacuum level (-94 kPa)
- Available in the cartridge-only or cartridge with holder and integrated silencer versions



Technical features

Max feed pressure	0.7 MPa
Temperature range	+14 - +176 °F
Weight	2.2 ± 15 g

Suction flow rate

Feed pressure [MPa]	Air consumption [NI/s]	Suction flow rate [NI/s] at different vacuum levels [kPa]										Max vacuum [kPa]
		0	-10	-20	-30	-40	-50	-60	-70	-80	-90	
0.5	0.47	0.76	0.63	0.54	0.32	0.17	0.15	0.11	0.07	0.05	0.01	-94
0.55	0.54	0.77	0.64	0.54	0.33	0.20	0.15	0.10	0.07	0.04	0.01	-92
0.6	0.55	0.74	0.63	0.53	0.47	0.29	0.14	0.10	0.08	0.05	0.01	-93

Evacuation time

Feed pressure [MPa]	Air consumption [NI/s]	Evacuation time [s/l] to reach different vacuum levels [kPa]										Max vacuum [kPa]
		-10	-20	-30	-40	-50	-60	-70	-80	-90		
0.5	0.47	0.14	0.32	0.55	1.0	1.6	2.4	3.5	5.1	8.7	-94	
0.55	0.54	0.14	0.31	0.54	0.9	1.5	2.3	3.5	5.3	8.7	-92	
0.6	0.55	0.15	0.32	0.52	0.8	1.3	2.1	3.2	4.7	8.6	-93	

Identification codes

Drawing	Alphanumeric code	Description	Order code
A	EJ-M-HV-2	EJ-MEDIUM-HV-2 without holder	3300015
B	EJ-M-HV-2-HS	EJ-MEDIUM-HV-2 with holder and integrated silencer	3300016
C	EJ-M-HV-2-NR	EJ-MEDIUM-HV-2 with non-return valve	3300017
D	EJ-M-HV-2-NR-HS	EJ-MEDIUM-HV-2 with holder, integrated silencer and non-return valve	3300018
E	EJ-M-HV-2-H	EJ-MEDIUM-HV-2 with holder	3300057

A C

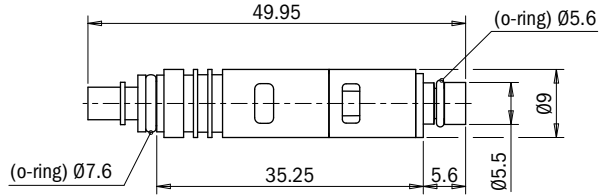

B D

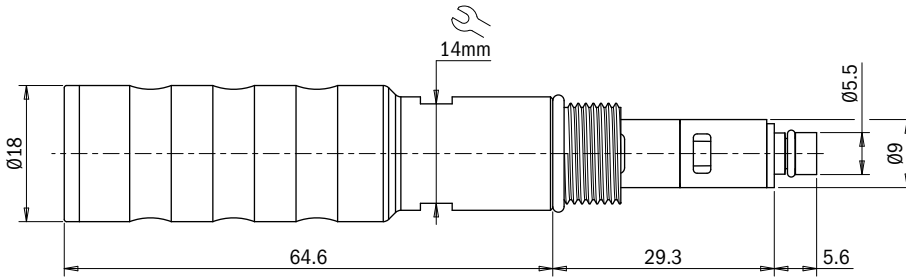

E

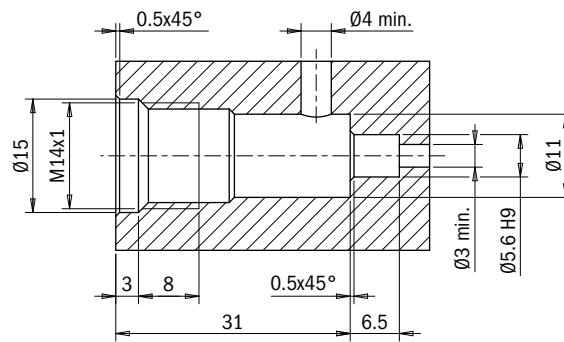
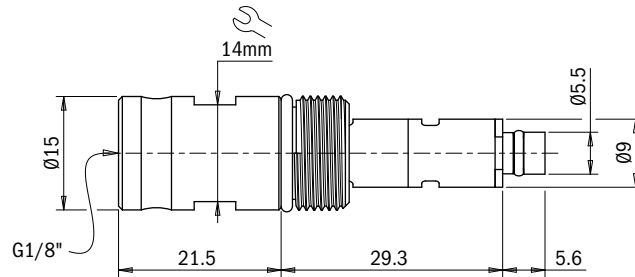

EJ-MEDIUM cartridges for integration

EJ-MEDIUM-HV-3

- Three-stage EJ-MEDIUM-HV-3 cartridge with compact dimensions
- High initial flow rate, reduces gripping time
- Suitable for handling sealed objects
- Fast response times at high vacuum levels
- Maximum vacuum level (-94 kPa)
- Available in the cartridge-only or cartridge with holder and integrated silencer versions



Technical features

Max feed pressure	0.7 MPa
Temperature range	+14 - +176 °F
Weight	3.9 ÷ 18.7 g

Suction flow rate

Feed pressure [MPa]	Air consumption [NI/s]	Suction flow rate [NI/s] at different vacuum levels [kPa]										Max vacuum [kPa]
		0	-10	-20	-30	-40	-50	-60	-70	-80	-90	
0.5	0.47	1.47	0.78	0.54	0.32	0.17	0.15	0.11	0.07	0.05	0.01	-94
0.55	0.54	1.48	0.79	0.54	0.33	0.20	0.15	0.10	0.07	0.04	0.01	-92
0.6	0.55	1.45	0.79	0.53	0.42	0.3	0.14	0.10	0.08	0.04	0.01	-93

Evacuation time

Feed pressure [MPa]	Air consumption [NI/s]	Evacuation time [s/l] to reach different vacuum levels [kPa]										Max vacuum [kPa]
		-10	-20	-30	-40	-50	-60	-70	-80	-90		
0.5	0.47	0.08	0.24	0.47	0.88	1.6	2.4	3.5	5.1	8.7	-94	
0.55	0.54	0.09	0.24	0.47	0.85	1.4	2.2	3.4	5.2	8.7	-92	
0.6	0.55	0.09	0.25	0.45	0.70	1.3	2.1	3.2	4.7	8.6	-93	

Identification codes

Drawing	Alphanumeric code	Description	Order code
A	EJ-M-HV-3	EJ-MEDIUM-HV-3 without holder	3300027
B	EJ-M-HV-3-HS	EJ-MEDIUM-HV-3 with holder and integrated silencer	3300028
C	EJ-M-HV-3-NR	EJ-MEDIUM-HV-3 with non-return valve	3300029
D	EJ-M-HV-3-NR-HS	EJ-MEDIUM-HV-3 with holder, integrated silencer and non-return valve	3300030
E	EJ-M-HV-3-H	EJ-MEDIUM-HV-3 with holder	3300060

A C

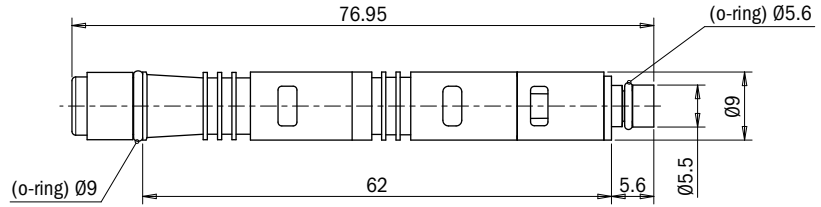

B D

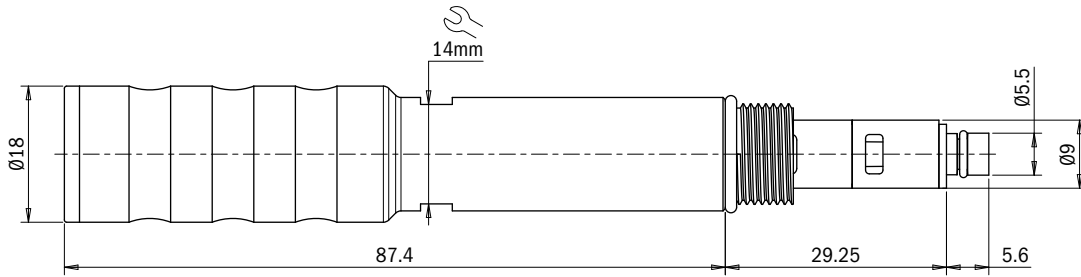

E

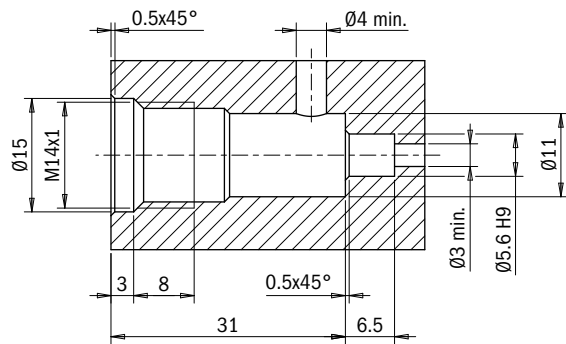
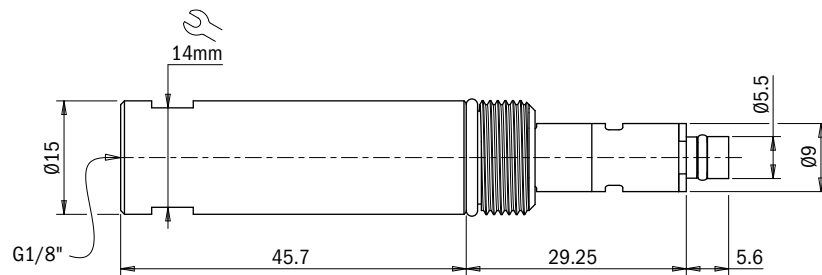

EJ-LARGE cartridges for integration

EJ-LARGE-LP-2

- Two-stage EJ-LARGE-LP-2 cartridge, small-sized
- Can be integrated near the gripping point
- Suitable and reliable even in the case of fluctuations in feed pressure
- Ideal for handling sealed objects
- Maximum vacuum level (-90 kPa)
- Available in the cartridge-only or cartridge with holder and integrated silencer versions



Technical features

Max feed pressure	0.7 MPa
Temperature range	+14 - +176 °F
Weight	15.3 ÷ 68.7 g

Suction flow rate

Feed pressure [MPa]	Air consumption [NI/s]	Suction flow rate [NI/s] at different vacuum levels [kPa]										Max vacuum [kPa]
		0	-10	-20	-30	-40	-50	-60	-70	-80	-90	
0.2	1.5	2.6	1.6	1.0	0.7	0.4	0.14	–	–	–	–	-60
0.35	2.3	2.9	2.6	1.8	1.4	0.94	0.47	0.29	0.25	0.08	–	-90
0.4	2.6	2.8	2.5	2.1	1.5	1.1	0.66	0.36	0.26	0.08	–	-89

Evacuation time

Feed pressure [MPa]	Air consumption [NI/s]	Evacuation time [s/l] to reach different vacuum levels [kPa]										Max vacuum [kPa]
		-10	-20	-30	-40	-50	-60	-70	-80	-90	-90	
0.2	1.5	0.05	0.12	0.24	0.4	0.8	–	–	–	–	–	-60
0.35	2.3	0.04	0.08	0.14	0.2	0.4	0.6	1.0	1.6	–	–	-90
0.4	2.6	0.04	0.07	0.14	0.19	0.3	0.5	0.8	1.4	–	–	-89

Identification codes

Drawing	Alphanumeric code	Description	Order code
A	EJ-L-LP-2	EJ-LARGE-LP-2 without holder	3300033
B	EJ-L-LP-2-HS	EJ-LARGE-LP-2 with holder and integrated silencer	3300034
C	EJ-L-LP-2-NR	EJ-LARGE-LP-2 with non-return valve	3300035
D	EJ-L-LP-2-NR-HS	EJ-LARGE-LP-2 with holder, integrated silencer and non-return valve	3300036
E	EJ-L-LP-2-H	EJ-LARGE-LP-2 with holder	3300065

A C

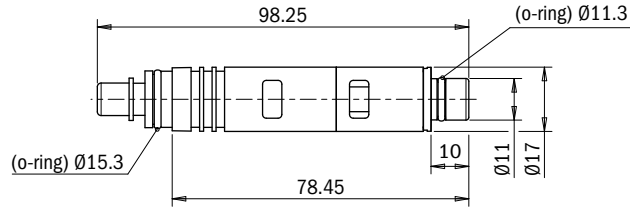

B D

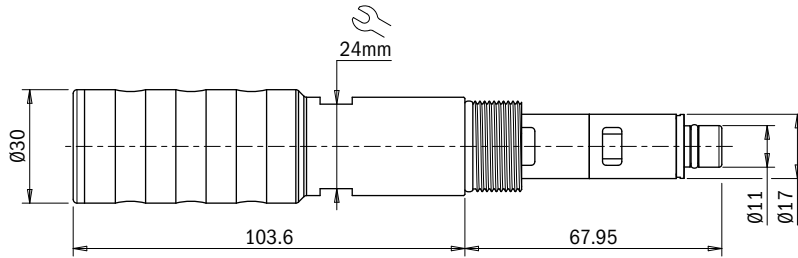

E

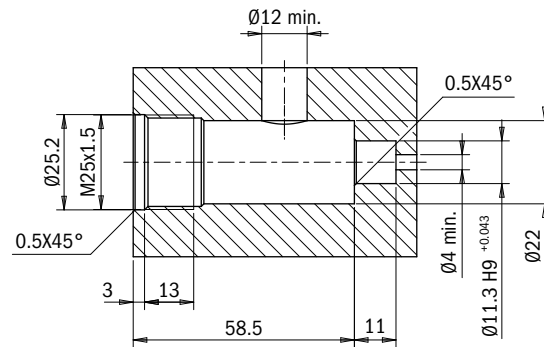
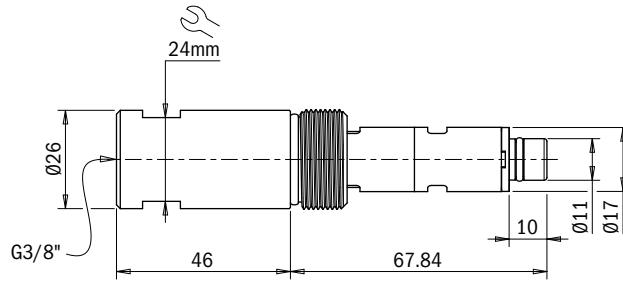

EJ-LARGE cartridges for integration

EJ-LARGE-LP-3

- Three-stage EJ-LARGE-LP-3 cartridge with compact dimensions
- High initial flow rate, reduces gripping time
- Can be integrated near the gripping point
- Suitable and reliable even in the case of fluctuations in feed pressure
- Ideal for handling sealed objects
- Maximum vacuum level (-90 kPa)
- Available in the cartridge-only or cartridge with holder and integrated silencer versions



Technical features

Max feed pressure	0.7 MPa
Temperature range	+14 - +176 °F
Weight	24.4 ÷ 84.4 g

Suction flow rate

Feed pressure [MPa]	Air consumption [NI/s]	Suction flow rate [NI/s] at different vacuum levels [kPa]										Max vacuum [kPa]
		0	-10	-20	-30	-40	-50	-60	-70	-80	-90	
0.2	1.5	4.0	1.6	1.0	0.7	0.4	0.14	–	–	–	–	-60
0.35	2.3	5.6	2.6	1.8	1.4	0.94	0.47	0.29	0.25	0.08	0.08	-90
0.4	2.6	5.7	2.5	2.1	1.5	1.1	0.66	0.36	0.26	0.08	0.08	-89

Evacuation time

Feed pressure [MPa]	Air consumption [NI/s]	Evacuation time [s/l] to reach different vacuum levels [kPa]										Max vacuum [kPa]
		-10	-20	-30	-40	-50	-60	-70	-80	-90	-90	
0.2	1.5	0.04	0.11	0.23	0.4	0.8	–	–	–	–	–	-60
0.35	2.3	0.02	0.07	0.13	0.2	0.4	0.6	1.0	1.6	–	–	-90
0.4	2.6	0.02	0.07	0.12	0.2	0.3	0.5	0.8	1.4	–	–	-89

Identification codes

Drawing	Alphanumeric code	Description	Order code
A	EJ-L-LP-3	EJ-LARGE-LP-3 without holder	3300037
B	EJ-L-LP-3-HS	EJ-LARGE-LP-3 with holder and integrated silencer	3300038
C	EJ-L-LP-3-NR	EJ-LARGE-LP-3 with non-return valve	3300039
D	EJ-L-LP-3-NR-HS	EJ-LARGE-LP-3 with holder, integrated silencer and non-return valve	3300040
E	EJ-L-LP-3-H	EJ-LARGE-LP-3 with holder	3300068

A C

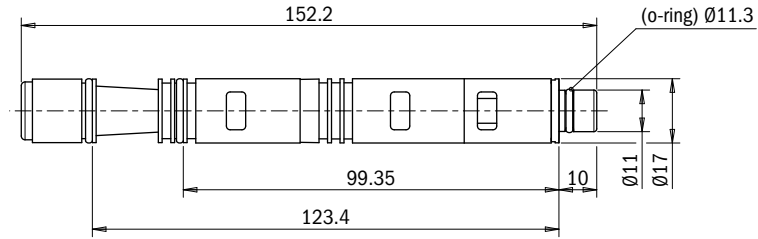

B D

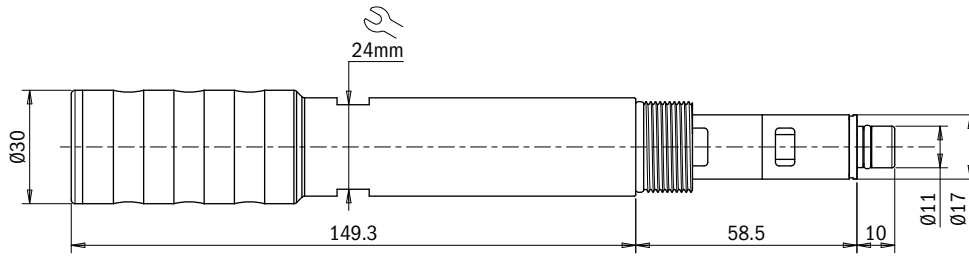

E

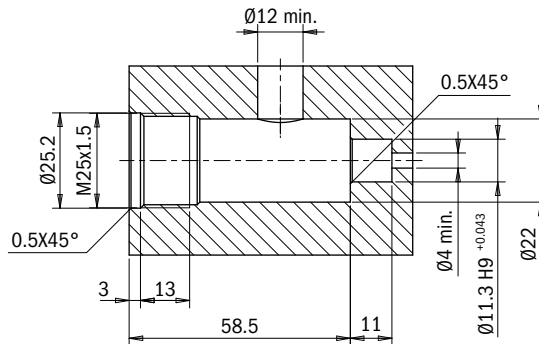
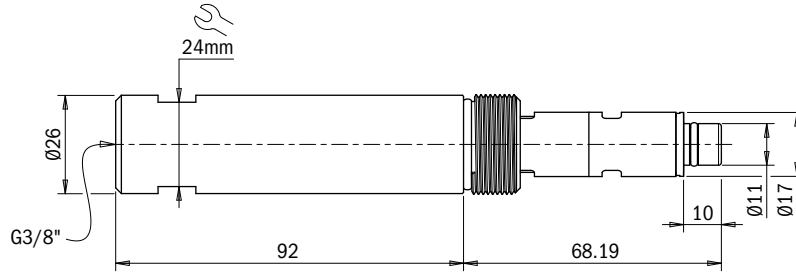

EJ-LARGE cartridges for integration

EJ-LARGE-HF-2

- Two-stage EJ-LARGE-HF-2 cartridge with compact dimensions
- Can be integrated near the gripping point
- Ideal for handling objects with uneven or porous surfaces
- Suitable for removing large volumes of air
- Able to compensate for any losses on the gripping surface
- Maximum vacuum level (-73 kPa)
- Available in the cartridge-only or cartridge with holder and integrated silencer versions



Technical features

Max feed pressure	0.7 MPa
Temperature range	+14 - +176 °F
Weight	15.3 ± 68.7 g

Suction flow rate

Feed pressure [MPa]	Air consumption [NI/s]	Suction flow rate [NI/s] at different vacuum levels [kPa]								Max vacuum [kPa]
		0	-10	-20	-30	-40	-50	-60	-70	
0.4	1.3	3.0	2.6	1.8	1.1	0.80	0.38	0.1	—	-60
0.5	1.5	3.1	2.8	2.1	1.4	0.86	0.60	0.30	0.18	-70
0.6	1.7	3.2	3.0	2.5	1.7	0.89	0.62	0.51	0.31	-73

Evacuation time

Feed pressure [MPa]	Air consumption [NI/s]	Evacuation time [s/l] to reach different vacuum levels [kPa]							Max vacuum [kPa]
		-10	-20	-30	-40	-50	-60	-70	
0.4	1.3	0.04	0.08	0.15	0.2	0.3	0.5	—	-60
0.5	1.5	0.03	0.07	0.13	0.2	0.3	0.5	0.7	-70
0.6	1.7	0.03	0.07	0.12	0.19	0.3	0.4	0.7	-73

Identification codes

Drawing	Alphanumeric code	Description	Order code
A	EJ-L-HF-2	EJ-LARGE-HF-2 without holder	3300041
B	EJ-L-HF-2-HS	EJ-LARGE-HF-2 with holder and integrated silencer	3300042
C	EJ-L-HF-2-NR	EJ-LARGE-HF-2 with non-return valve	3300043
D	EJ-L-HF-2-NR-HS	EJ-LARGE-HF-2 with holder, integrated silencer and non-return valve	3300044
E	EJ-L-HF-2-H	EJ-LARGE-HF-2 with holder	3300064

A C

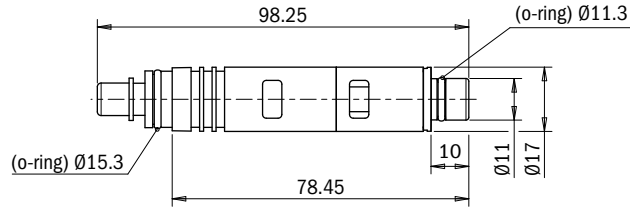

B D

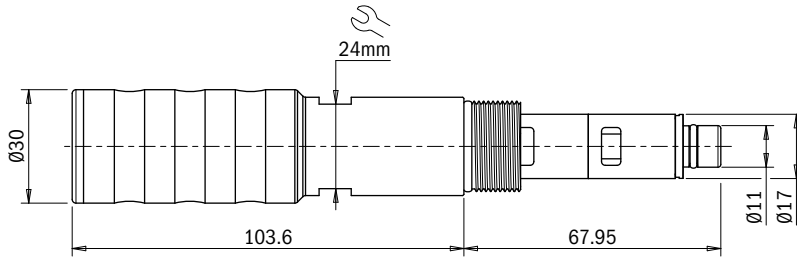

E

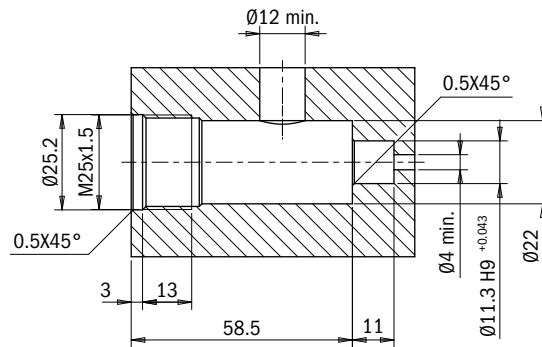
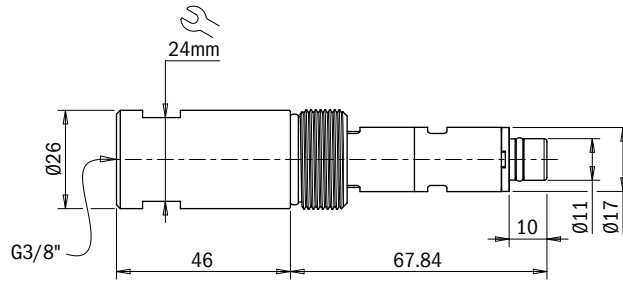

EJ-LARGE cartridges for integration

EJ-LARGE-HF-3

- Three-stage EJ-LARGE-HF-3 cartridge with compact dimensions
- High initial flow rate, reduces gripping time
- Suitable for handling objects with uneven or porous surfaces
- Can be integrated near the gripping point
- Able to compensate for any losses on the gripping surface
- High suction flow rate with low energy consumption
- Maximum vacuum level (-73 kPa)
- Available in the cartridge-only or cartridge with holder and integrated silencer versions



Technical features

Max feed pressure	0.7 MPa
Temperature range	+14 - +176 °F
Weight	24.4 ÷ 84.4 g

Suction flow rate

Feed pressure [MPa]	Air consumption [NI/s]	Suction flow rate [NI/s] at different vacuum levels [kPa]								Max vacuum [kPa]
		0	-10	-20	-30	-40	-50	-60	-70	
0.4	1.3	4.9	2.9	1.8	1.1	0.80	0.38	0.1	—	-60
0.5	1.5	5.6	3.2	2.1	1.4	0.86	0.60	0.30	0.18	-70
0.6	1.7	5.9	3.5	2.5	1.7	0.89	0.62	0.51	0.31	-73

Evacuation time

Feed pressure [MPa]	Air consumption [NI/s]	Evacuation time [s/l] to reach different vacuum levels [kPa]							Max vacuum [kPa]
		-10	-20	-30	-40	-50	-60	-70	
0.4	1.3	0.03	0.07	0.14	0.2	0.3	0.5	—	-60
0.5	1.5	0.02	0.06	0.12	0.2	0.3	0.5	0.7	-70
0.6	1.7	0.02	0.05	0.10	0.19	0.3	0.4	0.7	-73

Identification codes

Drawing	Alphanumeric code	Description	Order code
A	EJ-L-HF-3	EJ-LARGE-HF-3 without holder	3300045
B	EJ-L-HF-3-HS	EJ-LARGE-HF-3 with holder and integrated silencer	3300046
C	EJ-L-HF-3-NR	EJ-LARGE-HF-3 with non-return valve	3300047
D	EJ-L-HF-3-NR-HS	EJ-LARGE-HF-3 with holder, integrated silencer and non-return valve	3300048
E	EJ-L-HF-3-H	EJ-LARGE-HF-3 with holder	3300067

A C

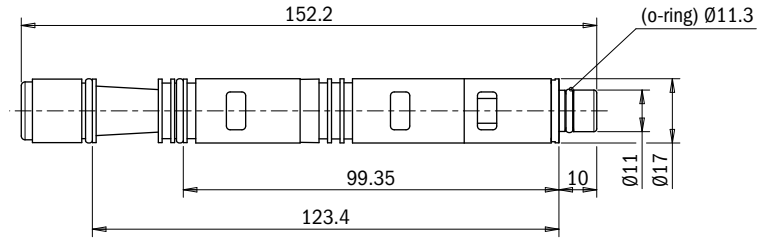

B D

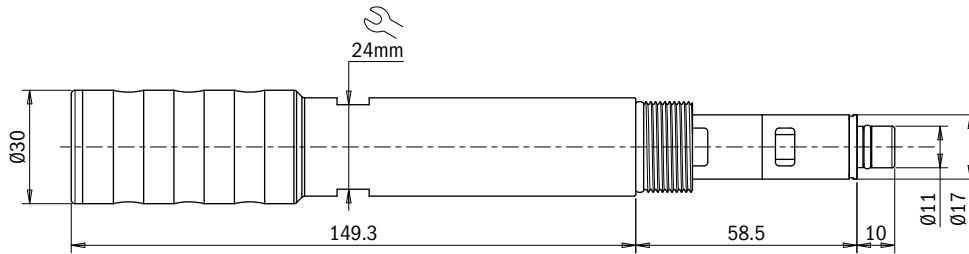

E

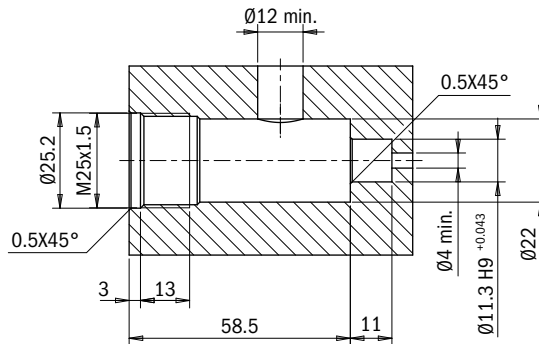
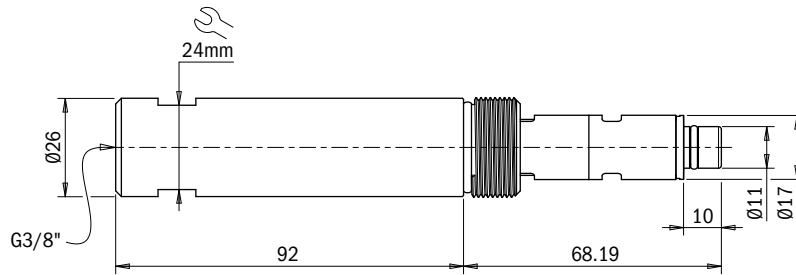

EJ-LARGE cartridges for integration

EJ-LARGE-HV-2

- Two-stage EJ-LARGE-HV-2 cartridge with compact dimensions
- Can be integrated near the gripping point
- Suitable for handling sealed objects, while being effective on porous products thanks to the high suction flow rate (between -30 and -50 kPa)
- Fast response times at high vacuum levels
- Maximum vacuum level (-94 kPa)
- Available in the cartridge-only or cartridge with holder and integrated silencer versions



Technical features

Max feed pressure	0.7 MPa
Temperature range	+14 - +176 °F
Weight	15.3 ÷ 68.7 g

Suction flow rate

Feed pressure [MPa]	Air consumption [l/s]	Suction flow rate [l/s] at different vacuum levels [kPa]										Max vacuum [kPa]
		0	-10	-20	-30	-40	-50	-60	-70	-80	-90	
0.45	1.82	2.8	2.3	1.7	1.0	0.70	0.58	0.40	0.31	0.18	0.03	-90
0.5	1.93	2.6	2.4	1.7	1.3	0.70	0.55	0.40	0.31	0.15	0.02	-94
0.6	2.33	2.7	2.4	2.0	1.6	1.03	0.68	0.36	0.30	0.14	0.02	-92

Evacuation time

Feed pressure [MPa]	Air consumption [l/s]	Evacuation time [s/l] to reach different vacuum levels [kPa]										Max vacuum [kPa]
		-10	-20	-30	-40	-50	-60	-70	-80	-90		
0.45	1.82	0.04	0.08	0.13	0.2	0.4	0.5	0.7	1.0	2.3	-90	
0.5	1.93	0.04	0.09	0.16	0.3	0.4	0.6	0.9	1.3	2.5	-94	
0.6	2.33	0.04	0.08	0.14	0.2	0.3	0.5	0.8	1.3	2.3	-92	

Identification codes

Drawing	Alphanumeric code	Description	Order code
A	EJ-L-HV-2	EJ-LARGE-HV-2 without holder	3300049
B	EJ-L-HV-2-HS	EJ-LARGE-HV-2 with holder and integrated silencer	3300050
C	EJ-L-HV-2-NR	EJ-LARGE-HV-2 with non-return valve	3300051
D	EJ-L-HV-2-NR-HS	EJ-LARGE-HV-2 with holder, integrated silencer and non-return valve	3300052
E	EJ-L-HV-2-H	EJ-LARGE-HV-2 with holder	3300063



Click for Pricing & Add to Cart

A C

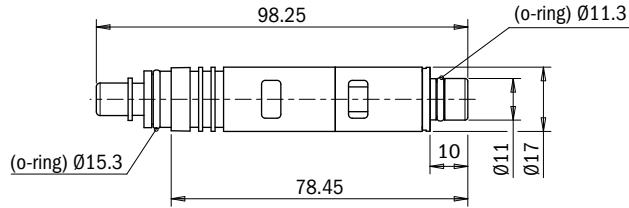

B D

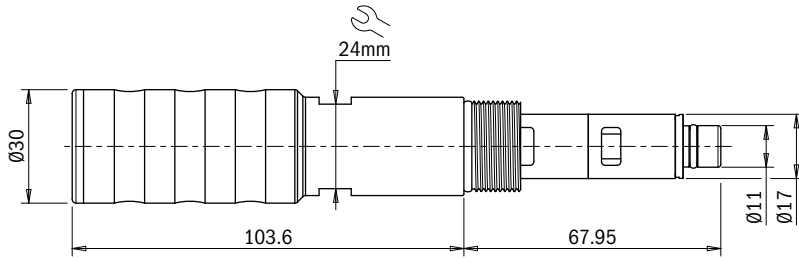

E

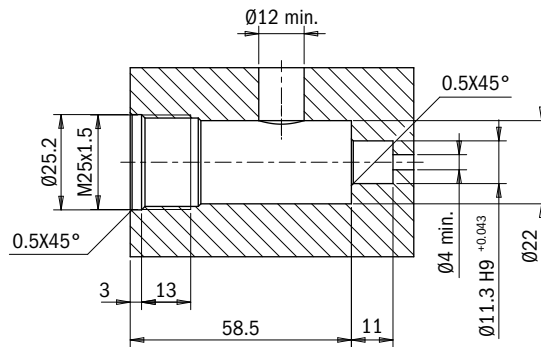
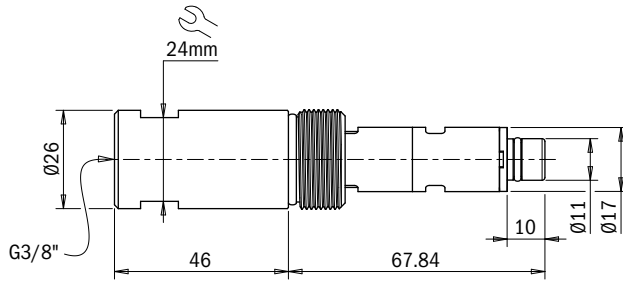

EJ-LARGE cartridges for integration

EJ-LARGE-HV-3

- Three-stage EJ-LARGE-HV-3 cartridge with compact dimensions
- High initial flow rate, reduces gripping time
- Suitable for handling sealed objects, while being effective on porous products thanks to the high suction flow rate (between -30 and -50 kPa)
- Fast response times at high vacuum levels
- Maximum vacuum level (-94 kPa)
- Available in the cartridge-only or cartridge with holder and integrated silencer versions



Technical features

Max feed pressure	0.7 MPa
Temperature range	+14 - +176 °F
Weight	24.4 ÷ 84.4 g

Suction flow rate

Feed pressure [MPa]	Air consumption [l/s]	Suction flow rate [l/s] at different vacuum levels [kPa]										Max vacuum [kPa]
		0	-10	-20	-30	-40	-50	-60	-70	-80	-90	
0.45	1.82	5.9	3.0	2.1	1.3	0.70	0.58	0.40	0.31	0.18	0.03	-90
0.5	1.93	6.0	3.7	2.1	1.9	0.79	0.55	0.40	0.31	0.15	0.02	-94
0.6	2.33	5.9	3.2	2.2	1.7	1.03	0.68	0.36	0.30	0.14	0.02	-92

Evacuation time

Feed pressure [MPa]	Air consumption [l/s]	Evacuation time [s/l] to reach different vacuum levels [kPa]										Max vacuum [kPa]
		-10	-20	-30	-40	-50	-60	-70	-80	-90		
0.45	1.82	0.02	0.06	0.12	0.2	0.4	0.5	0.7	1.0	2.3	-90	
0.5	1.93	0.02	0.06	0.10	0.2	0.3	0.4	0.7	1.1	2.4	-94	
0.6	2.33	0.02	0.06	0.11	0.2	0.3	0.5	0.8	1.3	2.3	-92	

Identification codes

Drawing	Alphanumeric code	Description	Order code
A	EJ-LHV-3	EJ-LARGE-HV-3 without holder	3300053
B	EJ-LHV-3-HS	EJ-LARGE-HV-3 with holder and integrated silencer	3300054
C	EJ-LHV-3-NR	EJ-LARGE-HV-3 with non-return valve	3300055
D	EJ-LHV-3-NR-HS	EJ-LARGE-HV-3 with holder, integrated silencer and non-return valve	3300056
E	EJ-LHV-3-H	EJ-LARGE-HV-3 with holder	3300066

A C

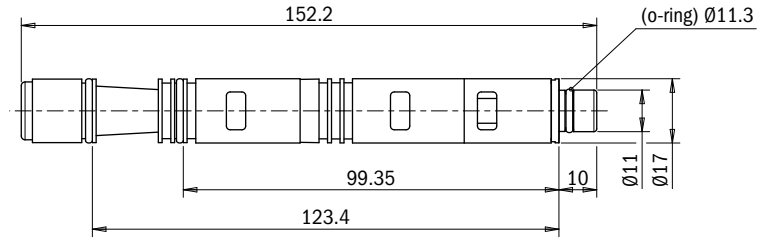

B D

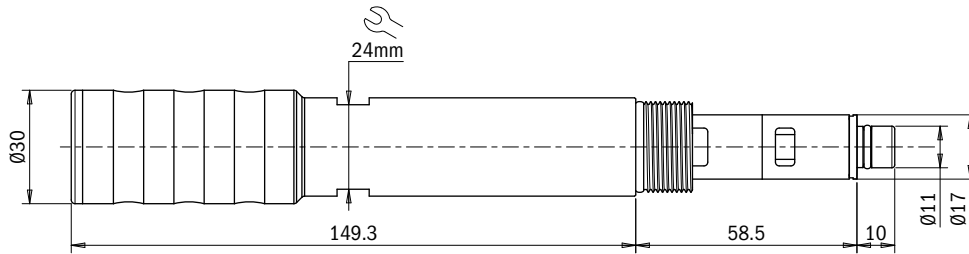

E

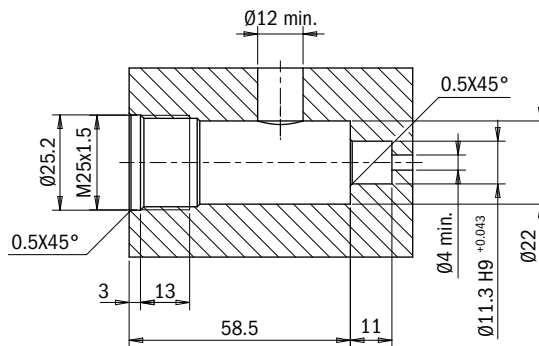
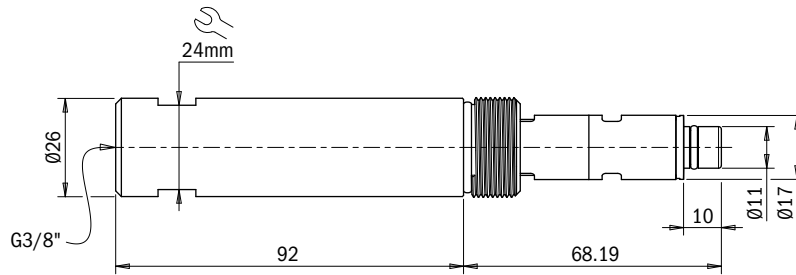

Introduction

Vacuum theory

Suction cups

Vacuum pumps

Customised solutions

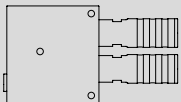
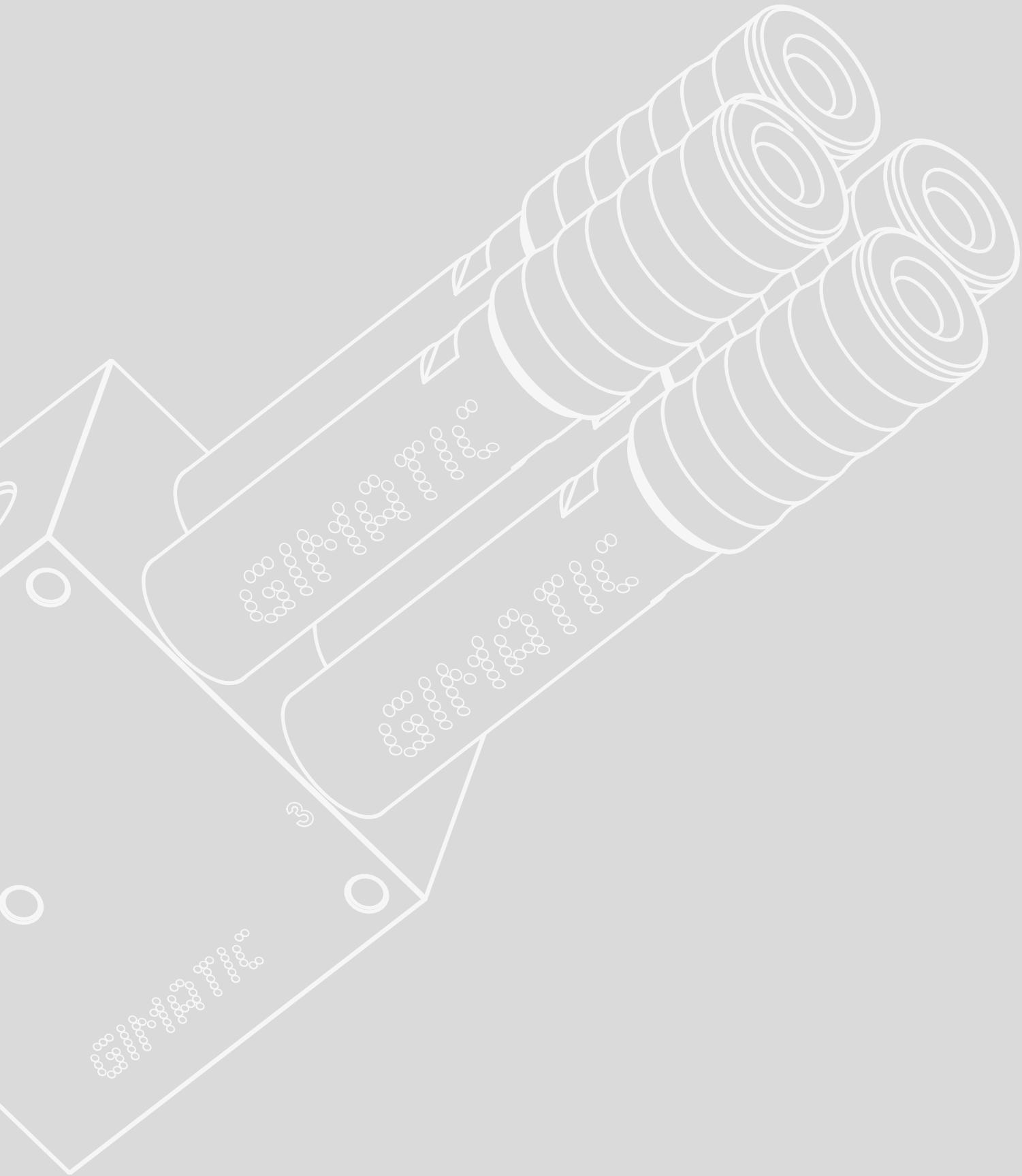

Suspensions

System accessories











VACUUM PUMPS

VACUUM PUMP SIZES

Size	Vacuum pump		Max suction flow rate
SMALL	EJ-LINE-SMALL		0.18 ÷ 0.50 [l/s]
	EJ-SYS-SMALL		
	EJ-ATM-LINE-SMALLX2		



[Click for Quick Navigation](#)

Size	Vacuum pump	Max suction flow rate
MEDIUM	EJ-LINE-MEDIUM 	0.57 ÷ 2.7 [Nl/s]
	EJ-BA-MEDIUM 	
	EJ-BA-MEDIUMX2 	
	EJ-SYS-MEDIUM 	
	EJ-SLG-MEDIUM 	
	EJ-ATM-MEDIUM 	
	EJ-BLOWOFF-MEDIUM 	
	EJ-BLOWOFF-MEDIUMX2 	
	EJ-BSV-MEDIUM 	

Introduction

Vacuum theory

Suction cups

Vacuum pumps

Customised solutions

Suspensions

System accessories

VACUUM PUMP SIZES

Size	Vacuum pump	Max suction flow rate	
LARGE	EJ-SYS-LARGE		2.6 ÷ 24 [NI/s]
	EJ-SLG-LARGE		
	EJ-BLOWOFF-LARGE		
	EJ-BSVLG-LARGE-ISO		
	EJ-MLG-LARGE2		
	EJ-MLG-LARGE3		
	EJ-MLG-LARGE4		
	EJ-CEN-LARGE		



Click for Quick Navigation

Size	Vacuum pump		Max suction flow rate
LARGE - BATTERY	EJ-XPRO		2.6 ÷ 12.8 [NI/s]

VACUUM PUMP DESCRIPTION

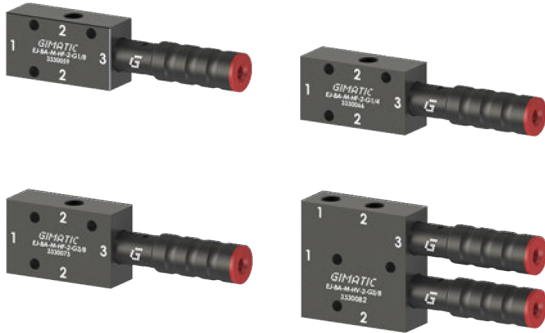

EJ-BA

The EJ-BA vacuum pumps consist of an anodized aluminum manifold, which guarantees high strength while allowing compact dimensions. They can integrate the EJ-MEDIUM cartridges in the 2 and 3-stage versions with integrated silencer.



EJ-LINE

EJ-LINE pumps have superior vacuum characteristics even at low or fluctuating mains pressure. In-line design to optimize overall dimensions. The aluminum body provides high strength, the thread in the vacuum port allows direct fixing of the suction cup, avoiding the need of additional pipes or fittings.



EJ-SYS

The EJ-SYS range of vacuum pumps allows to simplify the sizing and the installation in a vacuum circuit. Vacuum pumps suitable for both decentralized and centralized circuits, thanks to the high suction flow rate of the EJ-SYS-LARGE version.



EJ-SLG

The EJ-SLG vacuum pumps consist of a POM housing, which makes the pump extremely lightweight and compact. Both the EJ-SLG-MEDIUM and the EJ-SLG-LARGE solutions are available in two- and three-stage versions with integrated silencer. Possibility of prearrangement with pre-set Gimatic digital vacuum switch, VACSW-3N203-G (PNP) and VACSW-3M203-G (NPN) version.

EJ-ATM

Vacuum pump developed for sealed applications where, due to the high vacuum reached, an atmospheric release is required, in order to reduce the time of detachment of the handled item and to speed up the movement of the gripping tool.

The key features are lightweight, low energy consumption and easy installation.



EJ-BLOWOFF / EJ-BSV

The EJ-BLOWOFF vacuum pump is the right choice for high frequency Pick-and-Place applications. The built-in blow-off tank allows to release the handled object very quickly while keeping the EJ-MEDIUM cartridge clean, avoiding clogging in particularly dusty environments. Available in the version with 1 and 2 two-stage EJ-MEDIUM cartridges. The EJ-BSV version features an integrated 3/2 valve in the NC or NO version.

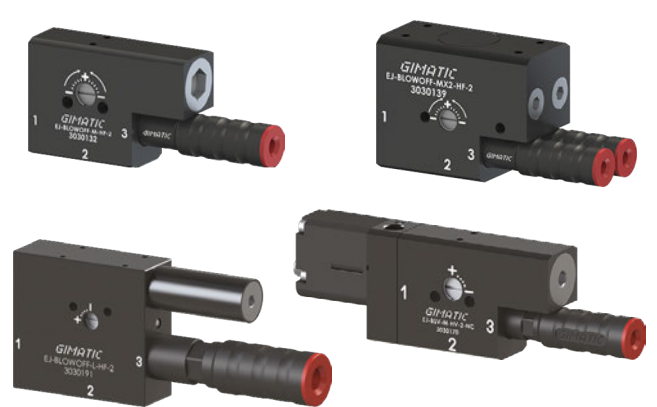

EJ-BSVL

Vacuum pump ideal for centralized or decentralized applications with integrated ISO vacuum/blow-off valve, suitable for handling parts with sealed or porous surfaces.

Extremely lightweight POM body with ISO design, available in the two- or three-stage EJ-LARGE versions.

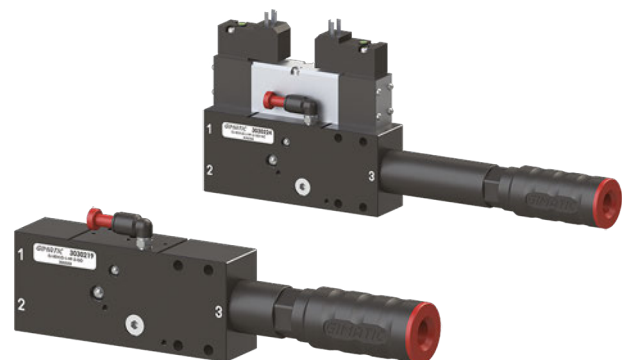

EJ-MLG

The design of the EJ-MLG vacuum pumps (body in POM) allows the integration of up to 4 EJ-LARGE cartridges, with 2 or 3 stages, making the vacuum pump a modular and flexible solution. Developed mainly for centralized applications, to simultaneously manage several suction cups or several users of the vacuum circuit.



VACUUM PUMP DESCRIPTION



EJ-CEN

Modular and configurable pump available in the configuration with 5 to 16 two-stage EJ-LARGE cartridges. It meets the requirements of centralised and decentralised applications where a high suction flow rate is required. Maintenance-free compact yet sturdy design. It can also be used as a blowing pump in applications with overpressure up to 0.15 MPa.

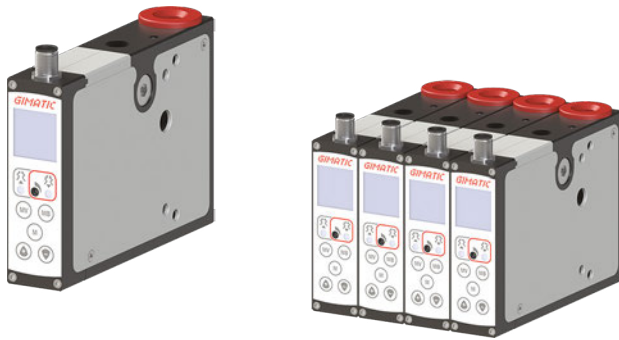

EJ-XPRO

Configurable vacuum pump with integrated control logic, featuring an energy-saving system that saves up to 95% compressed air in sealed applications. Available with two-stage EJ-LARGE cartridges.



EJ-BBT

The EJ-BBT vacuum generators are based on the Coanda principle and allow to achieve a high suction flow rate at low vacuum levels. This is particularly useful when handling porous and at the same time delicate objects. Also suitable for transporting waste materials (chips) or for cooling surfaces with high temperatures.

EJ-BA-MEDIUM

- Ideal for decentralized applications
- Low power consumption
- Can be integrated near the gripping point, lightweight
- G1/8" - G1/4" - G3/8" vacuum ports
- Auxiliary vacuum port, for possible blow-off or monitoring of the G1/8" system
- Available with two- and three-stage EJ-MEDIUM cartridge (EJ-LP, EJ-HF, EJ-HV)

Typical applications

- Handling of sealed items such as parts in glass and metal (EJ-HV)
- Packaging, cartoners, case packing machines (EJ-HF, EJ-LP)
- Plastic (molding)
- Automotive
- Particularly suitable for low cost automated applications

NEW



NEW



Application example

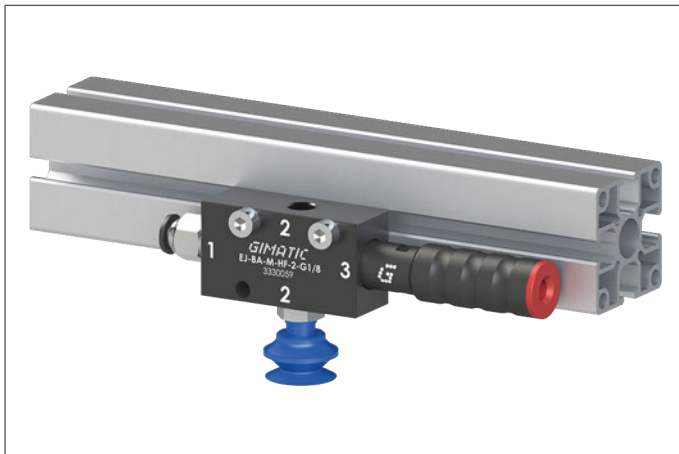

Technical features

Max feed pressure	0.7 MPa
Weight	83 ± 112 g
Material	POM, PA, Al, Nitrile (NBR)
Noise level	< 70 dB

Suction flow rate

Model	Feed pressure [MPa]	Air consumption [l/s]	Suction flow rate [l/s] at different vacuum levels [kPa]										Max vacuum [kPa]
			0	-10	-20	-30	-40	-50	-60	-70	-80	-90	
EJ-BA-M-LP-2	0.4	0.55	0.67	0.61	0.53	0.38	0.23	0.12	0.09	0.06	0.02	–	-89
EJ-BA-M-LP-3	0.4	0.55	1.5	0.71	0.53	0.38	0.23	0.12	0.09	0.06	0.02	–	-89
EJ-BA-M-HF-2	0.6	0.43	0.78	0.68	0.52	0.31	0.21	0.15	0.10	0.08	–	–	-73
EJ-BA-M-HF-3	0.6	0.43	1.35	0.75	0.55	0.31	0.21	0.15	0.10	0.08	–	–	-73
EJ-BA-M-HV-2	0.5	0.47	0.76	0.63	0.54	0.32	0.17	0.15	0.11	0.07	0.05	0.01	-94
EJ-BA-M-HV-3	0.5	0.47	1.47	0.78	0.54	0.32	0.17	0.15	0.11	0.07	0.05	0.01	-94

For technical specifications, regarding the suction flow rate and the air consumption at different pressures, please refer to the technical data sheets of the EJ-MEDIUM cartridges in the two- and three-stage versions

Evacuation time

Model	Feed pressure [MPa]	Air consumption [l/s]	Evacuation time [s/l] to reach different vacuum levels [kPa]										Max vacuum [kPa]
			-10	-20	-30	-40	-50	-60	-70	-80	-90		
EJ-BA-M-LP-2	0.4	0.55	0.17	0.33	0.55	0.9	1.5	2.4	3.7	7.1	–	-89	
EJ-BA-M-LP-3	0.4	0.55	0.08	0.23	0.44	0.76	1.4	2.4	3.7	7.1	–	-89	
EJ-BA-M-HF-2	0.6	0.43	0.13	0.30	0.54	0.9	1.5	2.3	3.2	–	–	-73	
EJ-BA-M-HF-3	0.6	0.43	0.10	0.25	0.48	0.8	1.3	2.3	3.2	–	–	-73	
EJ-BA-M-HV-2	0.5	0.47	0.14	0.32	0.55	1.0	1.6	2.4	3.5	5.1	8.7	-94	
EJ-BA-M-HV-3	0.5	0.47	0.08	0.24	0.47	0.88	1.6	2.4	3.5	5.1	8.7	-94	

For technical specifications regarding the evacuation time and the consumption at different pressures, please refer to the technical data sheets of the EJ-MEDIUM cartridges, in the two- and three-stage versions

Identification codes

Alphanumeric code	Description	Order code
EJ-BA-M-LP-2-G1/8	EJ-BA-MEDIUM-LP-2 vacuum pump with holder and integrated silencer, G1/8" vacuum port	3330057
EJ-BA-M-LP-3-G1/8	EJ-BA-MEDIUM-LP-3 vacuum pump with holder and integrated silencer, G1/8" vacuum port	3330058
EJ-BA-M-HF-2-G1/8	EJ-BA-MEDIUM-HF-2 vacuum pump with holder and integrated silencer, G1/8" vacuum port	3330059
EJ-BA-M-HF-3-G1/8	EJ-BA-MEDIUM-HF-3 vacuum pump with holder and integrated silencer, G1/8" vacuum port	3330060
EJ-BA-M-HV-2-G1/8	EJ-BA-MEDIUM-HV-2 vacuum pump with holder and integrated silencer, G1/8" vacuum port	3330061
EJ-BA-M-HV-3-G1/8	EJ-BA-MEDIUM-HV-3 vacuum pump with holder and integrated silencer, G1/8" vacuum port	3330062
EJ-BA-M-LP-2-G1/4	EJ-BA-MEDIUM-LP-2 vacuum pump with holder and integrated silencer, G1/4" vacuum port	3330064
EJ-BA-M-LP-3-G1/4	EJ-BA-MEDIUM-LP-3 vacuum pump with holder and integrated silencer, G1/4" vacuum port	3330065
EJ-BA-M-HF-2-G1/4	EJ-BA-MEDIUM-HF-2 vacuum pump with holder and integrated silencer, G1/4" vacuum port	3330066
EJ-BA-M-HF-3-G1/4	EJ-BA-MEDIUM-HF-3 vacuum pump with holder and integrated silencer, G1/4" vacuum port	3330067
EJ-BA-M-HV-2-G1/4	EJ-BA-MEDIUM-HV-2 vacuum pump with holder and integrated silencer, G1/4" vacuum port	3330068
EJ-BA-M-HV-3-G1/4	EJ-BA-MEDIUM-HV-3 vacuum pump with holder and integrated silencer, G1/4" vacuum port	3330069
EJ-BA-M-LP-2-G3/8	EJ-BA-MEDIUM-LP-2 vacuum pump with holder and integrated silencer, G3/8" vacuum port	3330071
EJ-BA-M-LP-3-G3/8	EJ-BA-MEDIUM-LP-3 vacuum pump with holder and integrated silencer, G3/8" vacuum port	3330072
EJ-BA-M-HF-2-G3/8	EJ-BA-MEDIUM-HF-2 vacuum pump with holder and integrated silencer, G3/8" vacuum port	3330073
EJ-BA-M-HF-3-G3/8	EJ-BA-MEDIUM-HF-3 vacuum pump with holder and integrated silencer, G3/8" vacuum port	3330074
EJ-BA-M-HV-2-G3/8	EJ-BA-MEDIUM-HV-2 vacuum pump with holder and integrated silencer, G3/8" vacuum port	3330075
EJ-BA-M-HV-3-G3/8	EJ-BA-MEDIUM-HV-3 vacuum pump with holder and integrated silencer, G3/8" vacuum port	3330076

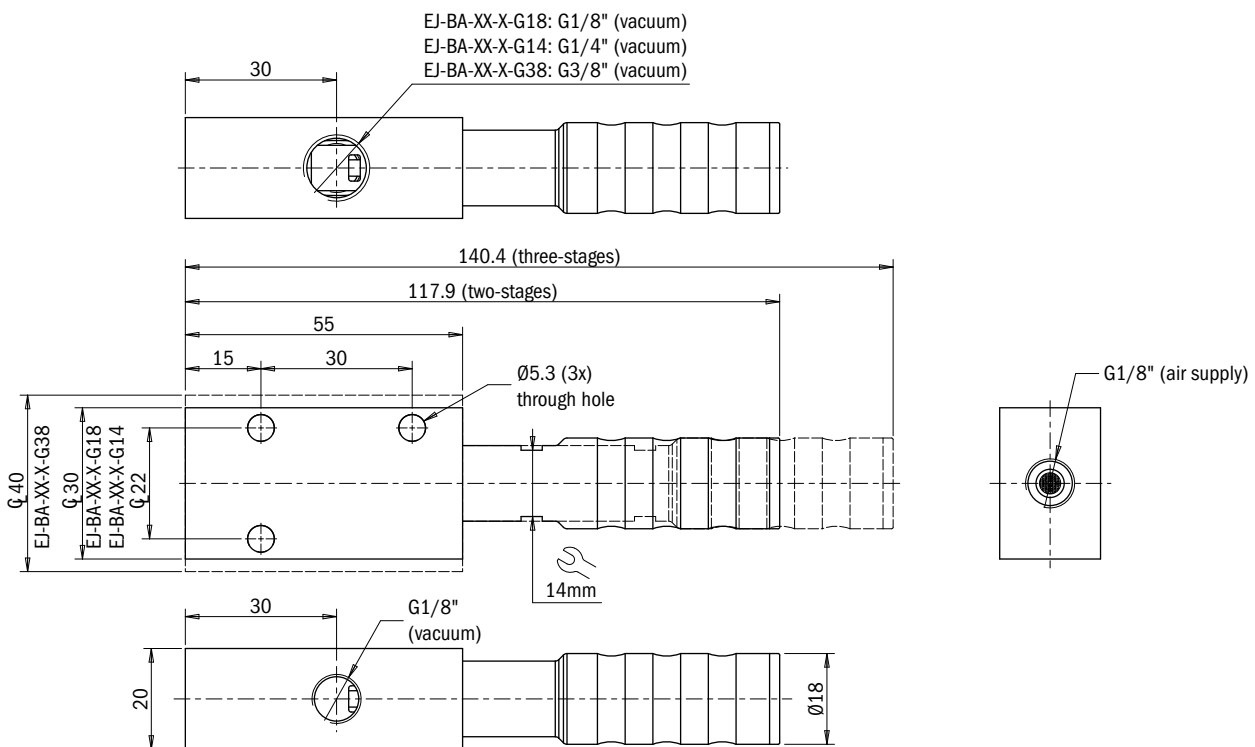

Identification codes		
Alphanumeric code	Description	Order code
EJ-BA-M-LP-2-G1/8-H NEW	EJ-BA-MEDIUM-LP-2 vacuum pump with holder, G1/8" vacuum port	3331057
EJ-BA-M-HF-2-G1/8-H NEW	EJ-BA-MEDIUM-HF-2 vacuum pump with holder, G1/8" vacuum port	3331059
EJ-BA-M-HV-2-G1/8-H NEW	EJ-BA-MEDIUM-HV-2 vacuum pump with holder, G1/8" vacuum port	3331061
EJ-BA-M-LP-2-G1/4-H NEW	EJ-BA-MEDIUM-LP-2 vacuum pump with holder, G1/4" vacuum port	3331064
EJ-BA-M-HF-2-G1/4-H NEW	EJ-BA-MEDIUM-HF-2 vacuum pump with holder, G1/4" vacuum port	3331066
EJ-BA-M-HV-2-G1/4-H NEW	EJ-BA-MEDIUM-HV-2 vacuum pump with holder, G1/4" vacuum port	3331068
EJ-BA-M-LP-2-G3/8-H NEW	EJ-BA-MEDIUM-LP-2 vacuum pump with holder, G3/8" vacuum port	3331071
EJ-BA-M-HF-2-G3/8-H NEW	EJ-BA-MEDIUM-HF-2 vacuum pump with holder, G3/8" vacuum port	3331073
EJ-BA-M-HV-2-G3/8-H NEW	EJ-BA-MEDIUM-HV-2 vacuum pump with holder, G3/8" vacuum port	3331075

3-stage configurations are also available on request

Click for Pricing & Add to Cart

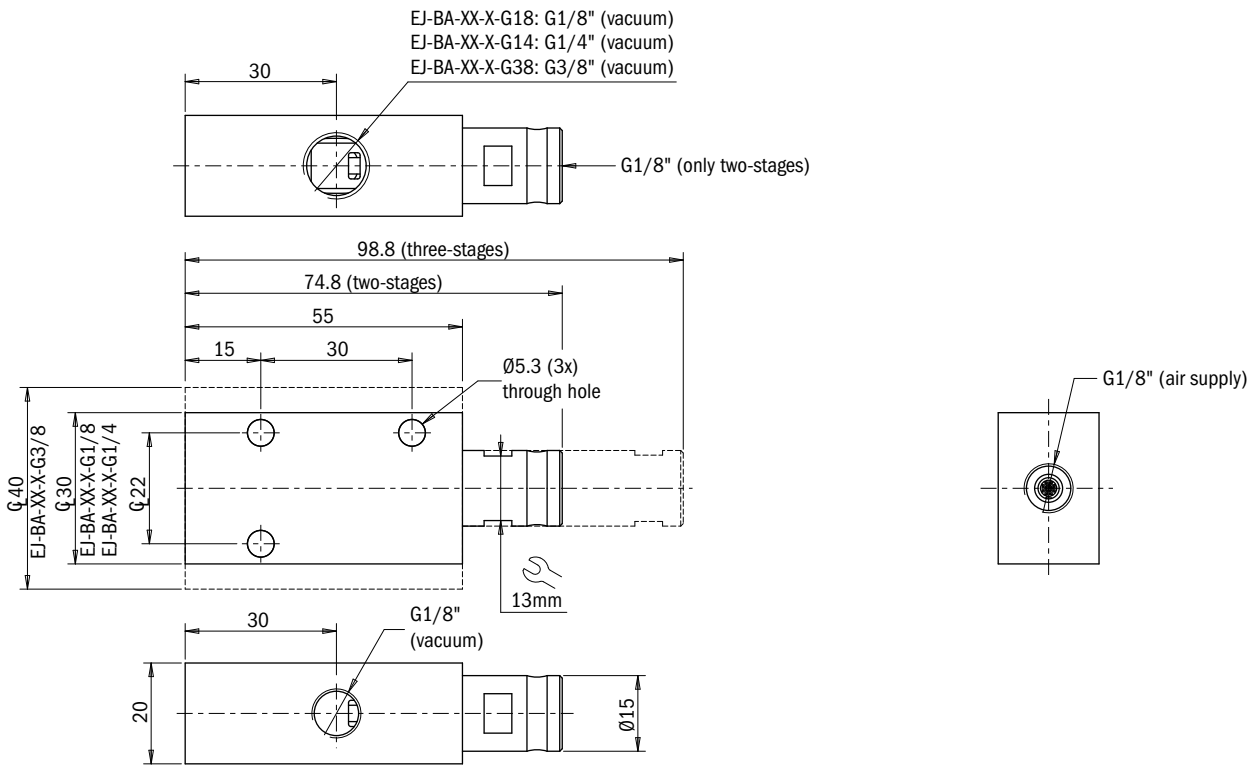

EJ-BA-MEDIUMX2

- Ideal for decentralized applications
- High ratio between suction flow rate and compressed air consumption
- Can be integrated near the gripping point, lightweight
- G3/8" vacuum port
- Auxiliary vacuum port, for possible blow-off or monitoring of the G1/8" system
- Available with two- and three-stage EJ-MEDIUM cartridge (EJ-LP, EJ-HF, EJ-HV)

Typical applications

- Handling of sealed items such as parts in glass and metal (EJ-HV)
- Packaging (cartoners, case packing machines) (EJ-HF, EJ-LP)
- Plastic (molding)
- Automotive

NEW



NEW



Application example

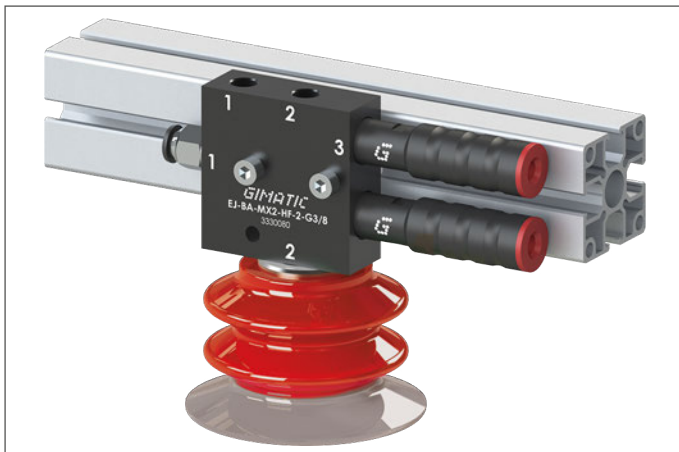

Technical features	
Max feed pressure	0.7 MPa
Weight	151 ± 158 g
Material	POM, PA, Al, Nitrile (NBR)
Noise level	< 70 dB

Suction flow rate													
Model	Feed pressure [MPa]	Air consumption [l/s]	Suction flow rate [l/s] at different vacuum levels [kPa]										Max vacuum [kPa]
			0	-10	-20	-30	-40	-50	-60	-70	-80	-90	
EJ-BA-MX2-LP-2-G3/8	0.4	1.1	1.34	1.22	1.06	0.76	0.46	0.24	0.18	0.12	0.04	–	-89
EJ-BA-MX2-LP-3-G3/8	0.4	1.1	3	1.42	1.06	0.76	0.46	0.24	0.18	0.12	0.04	–	-89
EJ-BA-MX2-HF-2-G3/8	0.6	0.86	1.56	1.36	1.04	0.62	0.42	0.30	0.20	0.16	–	–	-73
EJ-BA-MX2-HF-3-G3/8	0.6	0.86	2.70	1.50	1.10	0.62	0.42	0.30	0.20	0.16	–	–	-73
EJ-BA-MX2-HV-2-G3/8	0.5	0.94	1.52	1.26	1.08	0.64	0.34	0.30	0.22	0.14	0.01	0.02	-94
EJ-BA-MX2-HV-3-G3/8	0.5	0.94	2.94	1.56	1.08	0.64	0.34	0.30	0.22	0.14	0.01	0.02	-94

For technical specifications, regarding the suction flow rate and the air consumption at different pressures, please refer to the technical data sheets of the EJ-MEDIUM cartridges in the two- and three-stage versions

Evacuation time													
Model	Feed pressure [MPa]	Air consumption [l/s]	Evacuation time [s/l] to reach different vacuum levels [kPa]										Max vacuum [kPa]
			-10	-20	-30	-40	-50	-60	-70	-80	-90		
EJ-BA-MX2-LP-2-G3/8	0.4	1.1	0.085	0.165	0.275	0.45	0.75	1.2	1.85	3.55	–	–	-89
EJ-BA-MX2-LP-3-G3/8	0.4	1.1	0.04	0.115	0.22	0.38	0.70	1.2	1.85	3.55	–	–	-89
EJ-BA-MX2-HF-2-G3/8	0.6	0.86	0.065	0.15	0.27	0.45	0.75	1.15	1.6	–	–	–	-73
EJ-BA-MX2-HF-3-G3/8	0.6	0.86	0.05	0.125	0.24	0.40	0.65	1.15	1.6	–	–	–	-73
EJ-BA-MX2-HV-2-G3/8	0.5	0.94	0.07	0.16	0.275	0.50	0.88	1.2	1.75	2.55	4.35	–	-94
EJ-BA-MX2-HV-3-G3/8	0.5	0.94	0.08	0.24	0.47	0.88	0.80	1.2	1.75	2.55	4.35	–	-94

For technical specifications regarding the evacuation time and the consumption at different pressures, please refer to the technical data sheets of the EJ-MEDIUM cartridges, in the two- and three-stage versions

Identification codes

Alphanumeric code	Description	Order code
EJ-BA-MX2-LP-2-G3/8	EJ-BA-MEDIUMX2-LP-2 vacuum pump with holder and integrated silencer, G3/8" vacuum port	3330078
EJ-BA-MX2-LP-3-G3/8	EJ-BA-MEDIUMX2-LP-3 vacuum pump with holder and integrated silencer, G3/8" vacuum port	3330079
EJ-BA-MX2-HF-2-G3/8	EJ-BA-MEDIUMX2-HF-2 vacuum pump with holder and integrated silencer, G3/8" vacuum port	3330080
EJ-BA-MX2-HF-3-G3/8	EJ-BA-MEDIUMX2-HF-3 vacuum pump with holder and integrated silencer, G3/8" vacuum port	3330081
EJ-BA-MX2-HV-2-G3/8	EJ-BA-MEDIUMX2-HV-2 vacuum pump with holder and integrated silencer, G3/8" vacuum port	3330082
EJ-BA-MX2-HV-3-G3/8	EJ-BA-MEDIUMX2-HV-3 vacuum pump with holder and integrated silencer, G3/8" vacuum port	3330083

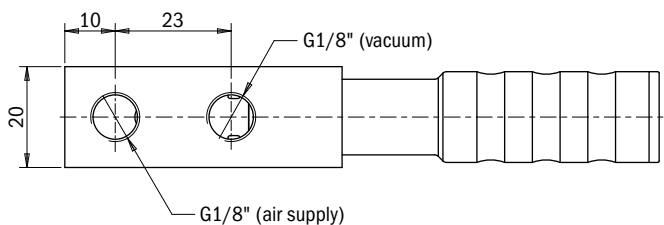
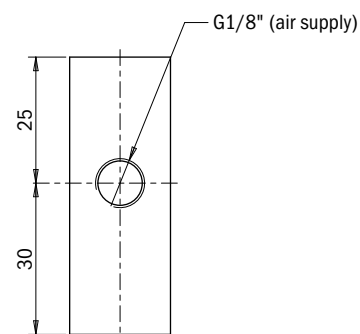
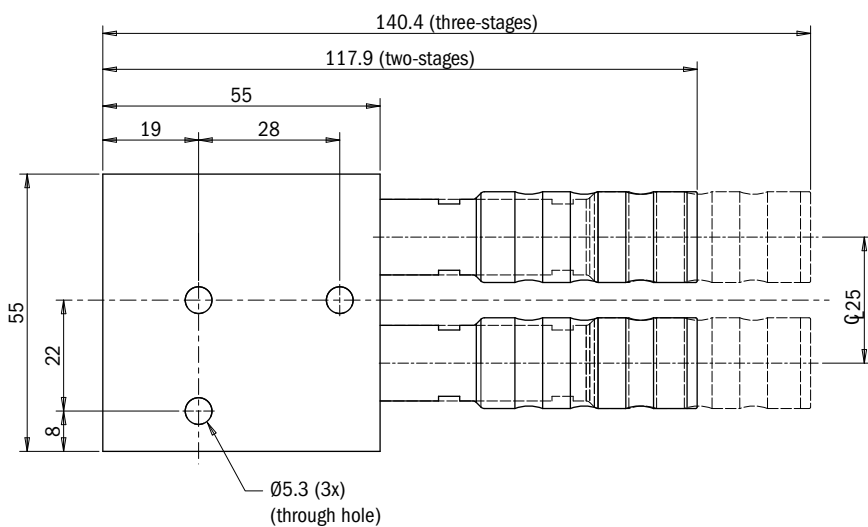
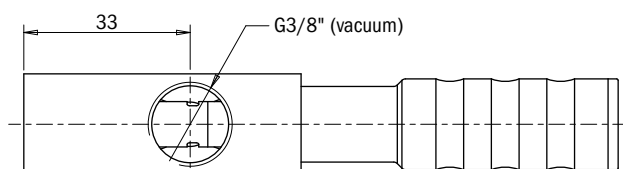

Identification codes			
Alphanumeric code		Description	Order code
EJ-BA-MX2-LP-2-G3/8-H	NEW	EJ-BA-MEDIUMX2-LP-2 vacuum pump with holder, G3/8" vacuum port	3331078
EJ-BA-MX2-HF-2-G3/8-H	NEW	EJ-BA-MEDIUMX2-HF-2 vacuum pump with holder, G3/8" vacuum port	3331080
EJ-BA-MX2-HV-2-G3/8-H	NEW	EJ-BA-MEDIUMX2-HV-2 vacuum pump with holder, G3/8" vacuum port	3331082

3-stage configurations are also available on request

Click for Pricing & Add to Cart

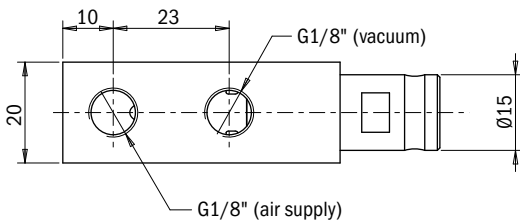
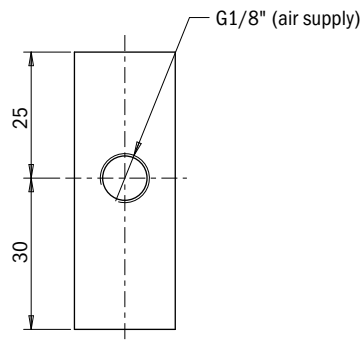
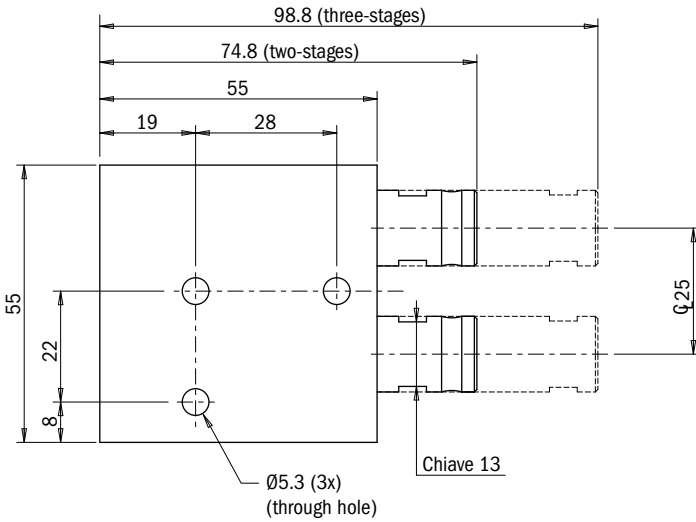
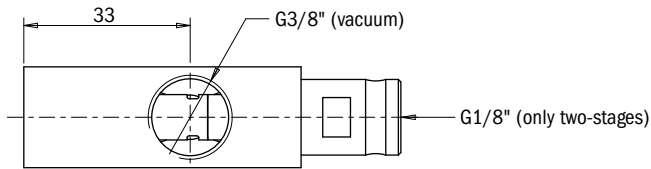

Vacuum pumps / EJ-LINE

EJ-LINE-SMALL

- Can be integrated near the gripping point, lightweight
- Clampable in-line design, to optimize overall dimensions
- No reduction of suction flow rate
- Flexible, enables the use of in-line or elbow fittings
- G1/8" vacuum ports
- Available with the two-stage EJ-SMALL cartridge (EJ-LP, EJ-HF, EJ-HV)

Typical applications

- Automated equipment for plastic molding
- Handling of metal sheets or plates (laser cutting, bending and punching machines)
- Pick-and-place (labeling machines)



Application example



Technical features

Max feed pressure	0.7 MPa
Weight	16.5 g
Material	PA, Al, Nitrile (NBR)
Noise level	< 70 dB

Suction flow rate

Model	Feed pressure [MPa]	Air consumption [NI/s]	Suction flow rate [NI/s] at different vacuum levels [kPa]										Max vacuum [kPa]
			0	-10	-20	-30	-40	-50	-60	-70	-80	-90	
EJ-LINE-S-LP-2-G1/8	0.22	0.17	0.25	0.18	0.08	0.05	0.04	0.025	0.018	0.0053	–	–	-82
EJ-LINE-S-HF-2-G1/8	0.6	0.15	0.29	0.18	0.10	0.08	0.05	0.041	0.033	0.025	–	–	-78
EJ-LINE-S-HV-2-G1/8	0.5	0.13	0.22	0.16	0.10	0.06	0.05	0.04	0.02	0.01	0.01	–	-92

For technical specifications, regarding the suction flow rate and the air consumption at different pressures, please refer to the technical data sheets of the EJ-SMALL-2 cartridges

Evacuation time												
Model	Feed pressure [MPa]	Air consumption [l/s]	Evacuation time [s/l] to reach different vacuum levels [kPa]									Max vacuum [kPa]
			-10	-20	-30	-40	-50	-60	-70	-80	-90	
EJ-LINE-S-LP-2-G1/8	0.22	0.17	0.47	1.23	2.77	5.0	8.07	12.70	21.30	59.01	–	-82
EJ-LINE-S-HF-2-G1/8	0.6	0.15	0.43	1.14	2.25	3.8	6.0	8.7	12.1	–	–	-78
EJ-LINE-S-HV-2-G1/8	0.5	0.13	0.53	1.30	2.55	4.4	6.6	9.9	16.6	36.6	–	-92

For technical specifications regarding evacuation time and consumption at different pressures, please refer to the technical data sheets of the EJ-SMALL-2 cartridges

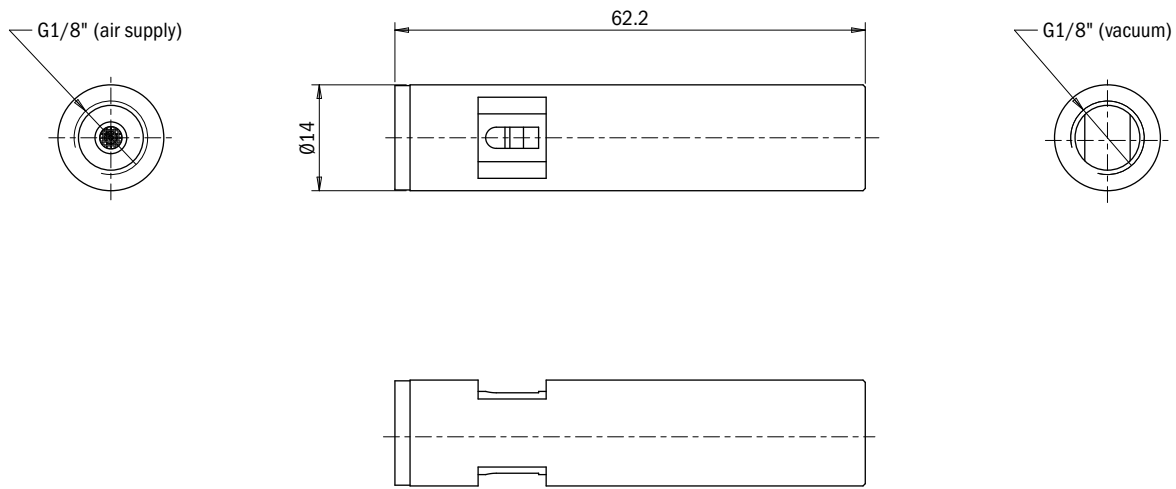

Identification codes		
Alphanumeric code	Description	Order code
EJ-LINE-S-LP-2-G1/8	EJ-LINE-SMALL-LP-2 G1/8" vacuum pump	3330084
EJ-LINE-S-HF-2-G1/8	EJ-LINE-SMALL-HF-2 G1/8" vacuum pump	3330085
EJ-LINE-S-HV-2-G1/8	EJ-LINE-SMALL-HV-2 G1/8" vacuum pump	3330086

Vacuum pumps / EJ-LINE

EJ-LINE-MEDIUM

- Can be integrated near the gripping point, lightweight
- Clampable in-line design, to optimize overall dimensions
- No reduction of suction flow rate
- Flexible, enables the use of in-line or elbow fittings
- Fast response times and high energy efficiency
- G1/4" vacuum ports
- Available with two-stage EJ-MEDIUM cartridge (EJ-LP, EJ-HF, EJ-HV)

Typical applications

- Automated equipment for plastic molding
- Handling of metal sheets or plates (laser cutting, bending and punching machines)
- Pick-and-place (labeling machines)



Application example

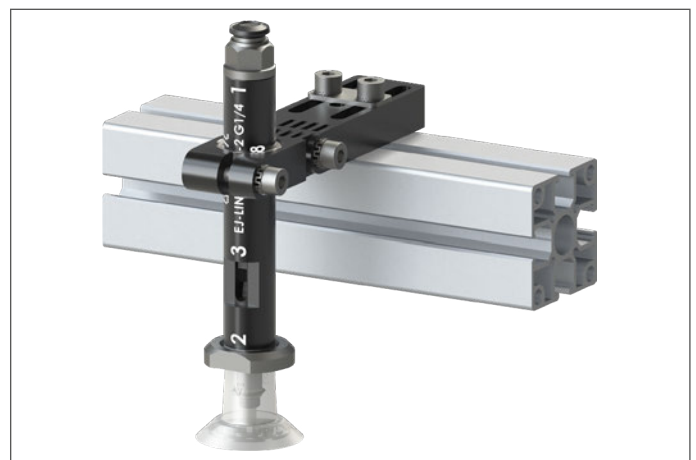

Technical features

Max feed pressure	0.7 MPa
Weight	27 g
Material	PA, Al, Nitrile (NBR)
Noise level	< 70 dB

Suction flow rate

Model	Feed pressure [MPa]	Air consumption [l/s]	Suction flow rate [l/s] at different vacuum levels [kPa]											Max vacuum [kPa]
			0	-10	-20	-30	-40	-50	-60	-70	-80	-90		
EJ-LINE-M-LP-2-G1/4	0.4	0.55	0.67	0.61	0.53	0.38	0.23	0.12	0.09	0.06	0.02	–	-89	
EJ-LINE-M-HF-2-G1/4	0.6	0.43	0.78	0.68	0.52	0.31	0.21	0.15	0.10	0.08	–	–	-73	
EJ-LINE-M-HV-2-G1/4	0.5	0.47	0.76	0.63	0.54	0.32	0.17	0.15	0.11	0.07	0.05	0.01	-94	

For technical specifications, regarding the suction flow rate and the air consumption at different pressures, please refer to the technical data sheets of the EJ-MEDIUM cartridges in the two-stage version

Evacuation time

Model	Feed pressure [MPa]	Air consumption [NI/s]	Evacuation time [s/l] to reach different vacuum levels [kPa]									Max vacuum [kPa]
			-10	-20	-30	-40	-50	-60	-70	-80	-90	
EJ-LINE-M-LP-2-G1/4	0.4	0.55	0.17	0.33	0.55	0.9	1.5	2.4	3.7	7.1	—	-89
EJ-LINE-M-HF-2-G1/4	0.6	0.43	0.13	0.30	0.54	0.9	1.5	2.3	3.2	—	—	-73
EJ-LINE-M-HV-2-G1/4	0.5	0.47	0.14	0.32	0.55	1.0	1.6	2.4	3.5	5.1	8.7	-94

For technical specifications regarding the evacuation time and the consumption at different pressures, please refer to the technical data sheets of the EJ-MEDIUM cartridges, in the two-stage version

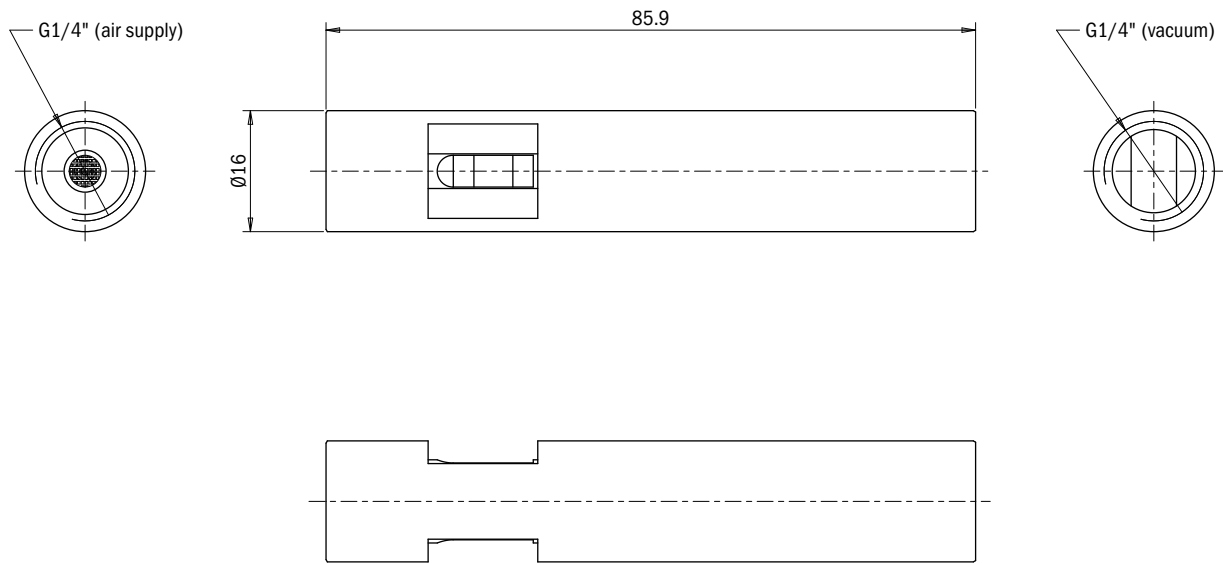

Identification codes

Alphanumeric code	Description	Order code
EJ-LINE-M-LP-2-G1/4	EJ-LINE-MEDIUM-LP-2 G1/4" vacuum pump	3330087
EJ-LINE-M-HF-2-G1/4	EJ-LINE-MEDIUM-HF-2 G1/4" vacuum pump	3330088
EJ-LINE-M-HV-2-G1/4	EJ-LINE-MEDIUM-HV-2 G1/4" vacuum pump	3330089

EJ-SYS-SMALL

- Ideal for decentralized applications
- Can be integrated near the gripping point, lightweight
- Anodized aluminum body
- Available with the two-stage EJ-SMALL cartridge (EJ-LP, EJ-HF, EJ-HV)

Typical applications

- Robotics
- Plastic (molding)
- Handling of small objects, electronics and semiconductors industries

Application example

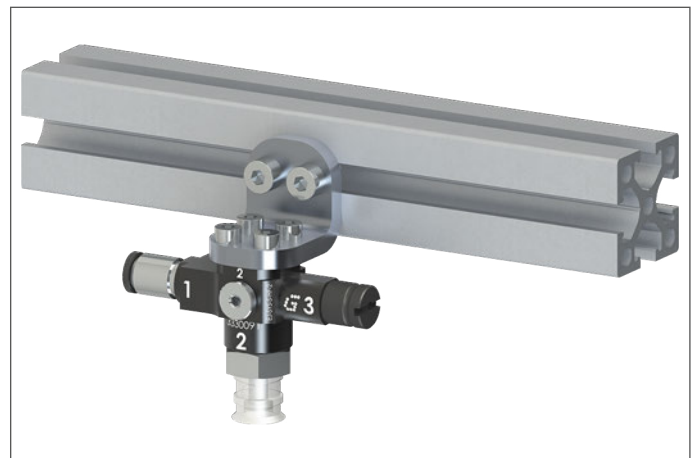

Technical features

Max feed pressure	0.7 MPa
Weight	12.4 g
Material	PA, SS, Al, Nitrile (NBR)
Noise level	< 70 dB

Suction flow rate

Model	Feed pressure [MPa]	Air consumption [NI/s]	Suction flow rate [NI/s] at different vacuum levels [kPa]										Max vacuum [kPa]
			0	-10	-20	-30	-40	-50	-60	-70	-80	-90	
EJ-SYS-S-LP-2	0.22	0.17	0.25	0.18	0.08	0.05	0.04	0.025	0.018	0.0053	–	–	-82
EJ-SYS-S-HF-2	0.6	0.15	0.29	0.18	0.10	0.08	0.05	0.041	0.033	0.025	–	–	-78
EJ-SYS-S-HV-2	0.5	0.13	0.22	0.16	0.10	0.06	0.05	0.04	0.02	0.01	0.01	–	-92

For technical specifications, regarding the suction flow rate and the air consumption at different pressures, please refer to the technical data sheets of the two-stage EJ-SMALL cartridges

Evacuation time

Model	Feed pressure [MPa]	Air consumption [l/s]	Evacuation time [s/l] to reach different vacuum levels [kPa]									Max vacuum [kPa]
			-10	-20	-30	-40	-50	-60	-70	-80	-90	
EJ-SYS-S-LP-2	0.22	0.17	0.47	1.23	2.77	5.0	8.07	12.70	21.30	59.01	–	-82
EJ-SYS-S-HF-2	0.6	0.15	0.43	1.14	2.25	3.8	6.0	8.7	12.1	–	–	-78
EJ-SYS-S-HV-2	0.5	0.13	0.53	1.30	2.55	4.4	6.6	9.9	16.6	36.6	–	-92

For technical specifications regarding evacuation time and consumption at different pressures, please refer to the technical data sheets of the two-stage EJ-SMALL cartridges

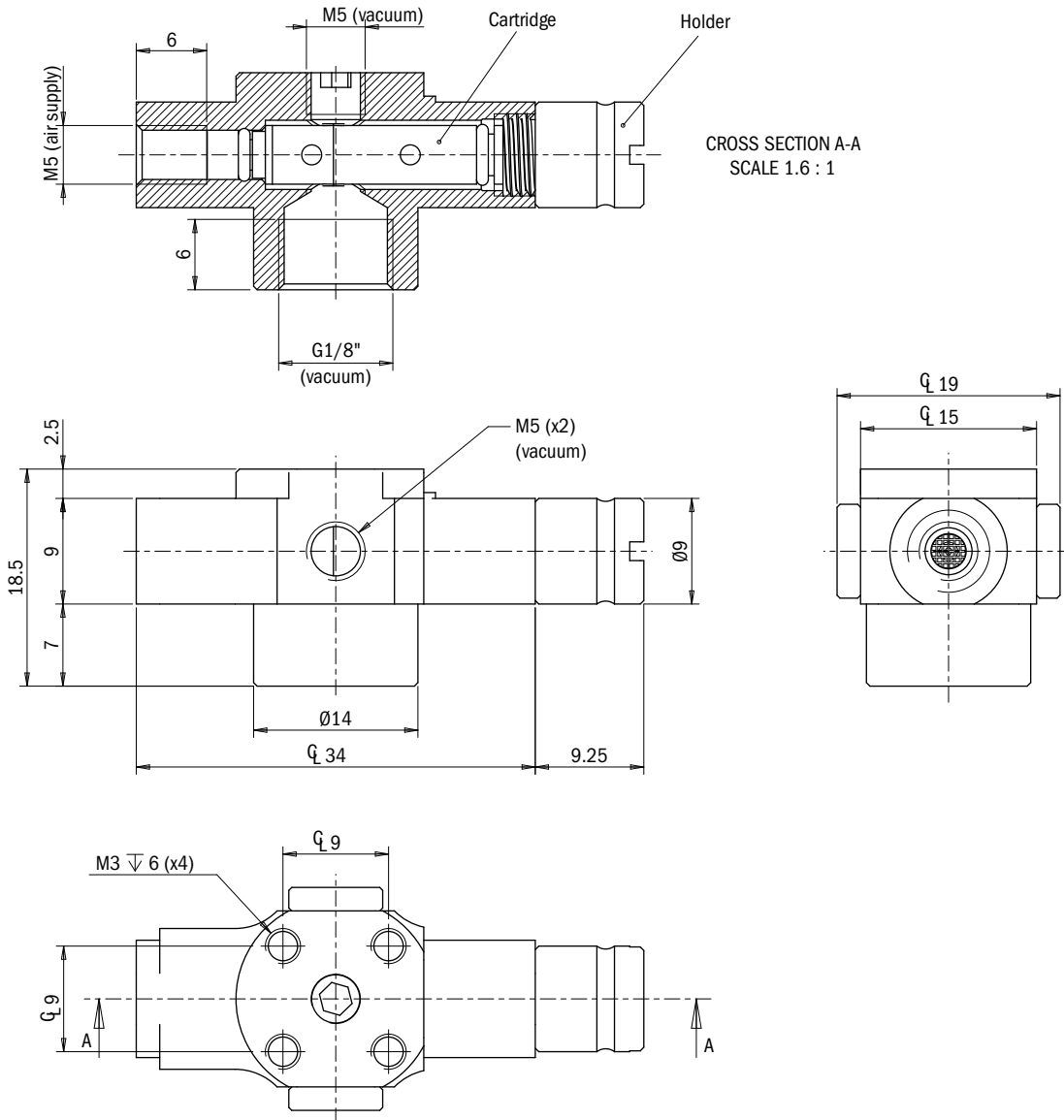

Identification codes

Alphanumeric code	Description	Order code
EJ-SYS-S-LP-2	EJ-SYS-SMALL-LP-2 vacuum pump with holder	3330090
EJ-SYS-S-HF-2	EJ-SYS-SMALL-HF-2 vacuum pump with holder	3330091
EJ-SYS-S-HV-2	EJ-SYS-SMALL-HV-2 vacuum pump with holder	3330092

Vacuum pumps / EJ-SYS

EJ-SYS-MEDIUM

- Ideal for decentralized applications
- Easy installation and positioning thanks to several mounting options
- Anodized aluminum body
- G3/8" vacuum port
- Integrated silencer
- The three-stage cartridge offers a higher initial flow rate, ideal for high speed applications
- Available with two- and three-stage EJ-MEDIUM cartridge (EJ-LP, EJ-HF, EJ-HV)

Typical applications

- Particularly suitable for sealed applications where high speed and reliability is required (EJ-HV)
- Packaging (forming machines, case packers), opening and closing of cardboard boxes (EJ-LP, EJ-HF)
- Pick-and-Place for handling electronic components



Application example



Technical features

Max feed pressure	0.7 MPa
Weight	61 ÷ 65 g
Material	PA, POM, SS, Al, Nitrile (NBR)
Noise level	< 70 dB

Suction flow rate

Model	Feed pressure [MPa]	Air consumption [l/s]	Suction flow rate [l/s] at different vacuum levels [kPa]										Max vacuum [kPa]
			0	-10	-20	-30	-40	-50	-60	-70	-80	-90	
EJ-SYS-M-LP-2	0.4	0.55	0.67	0.61	0.53	0.38	0.23	0.12	0.09	0.06	0.02	–	-89
EJ-SYS-M-LP-3	0.4	0.55	1.5	0.71	0.53	0.38	0.23	0.12	0.09	0.06	0.02	–	-89
EJ-SYS-M-HF-2	0.6	0.43	0.78	0.68	0.52	0.31	0.21	0.15	0.10	0.08	–	–	-73
EJ-SYS-M-HF-3	0.6	0.43	1.35	0.75	0.55	0.31	0.21	0.15	0.10	0.08	–	–	-73
EJ-SYS-M-HV-2	0.5	0.47	0.76	0.63	0.54	0.32	0.17	0.15	0.11	0.07	0.05	0.01	-94
EJ-SYS-M-HV-3	0.5	0.47	1.47	0.78	0.54	0.32	0.17	0.15	0.11	0.07	0.05	0.01	-94

For technical specifications, regarding the suction flow rate and the air consumption at different pressures, please refer to the technical data sheets of the EJ-MEDIUM cartridges in the two- and three-stage versions

Evacuation time

Model	Feed pressure [MPa]	Air consumption [NI/s]	Evacuation time [s/l] to reach different vacuum levels [kPa]										Max vacuum [kPa]
			-10	-20	-30	-40	-50	-60	-70	-80	-90		
EJ-SYS-M-LP-2	0.4	0.55	0.17	0.33	0.55	0.9	1.5	2.4	3.7	7.1	—	-89	
EJ-SYS-M-LP-3	0.4	0.55	0.08	0.23	0.44	0.76	1.4	2.4	3.7	7.1	—	-89	
EJ-SYS-M-HF-2	0.6	0.43	0.13	0.30	0.54	0.9	1.5	2.3	3.2	—	—	-73	
EJ-SYS-M-HF-3	0.6	0.43	0.10	0.25	0.48	0.8	1.3	2.3	3.2	—	—	-73	
EJ-SYS-M-HV-2	0.5	0.47	0.14	0.32	0.55	1.0	1.6	2.4	3.5	5.1	8.7	-94	
EJ-SYS-M-HV-3	0.5	0.47	0.08	0.24	0.47	0.88	1.6	2.4	3.5	5.1	8.7	-94	

For technical specifications regarding the evacuation time and the consumption at different pressures, please refer to the technical data sheets of the EJ-MEDIUM cartridges, in the two- and three-stage versions

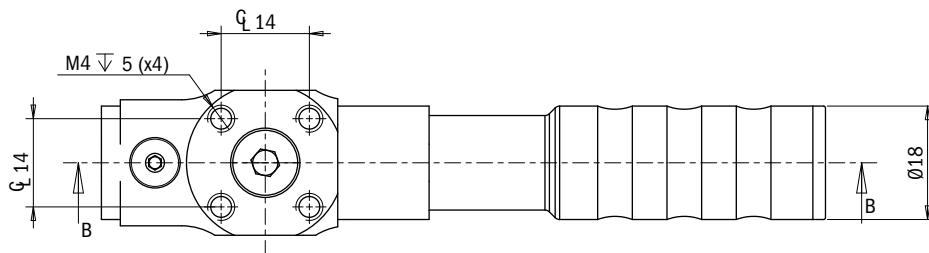
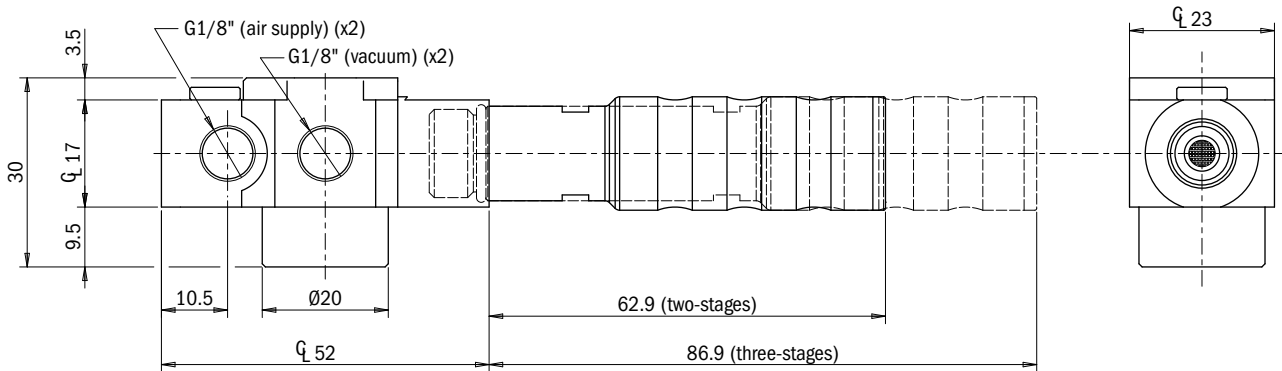
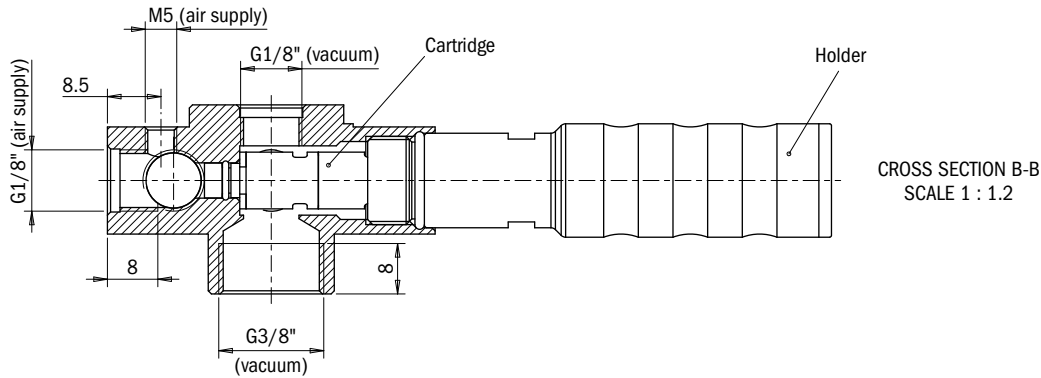

Identification codes

Alphanumeric code	Description	Order code
EJ-SYS-M-LP-2	EJ-SYS-MEDIUM-LP-2 vacuum pump with holder and integrated silencer	3330093
EJ-SYS-M-LP-3	EJ-SYS-MEDIUM-LP-3 vacuum pump with holder and integrated silencer	3330094
EJ-SYS-M-HF-2	EJ-SYS-MEDIUM-HF-2 vacuum pump with holder and integrated silencer	3330095
EJ-SYS-M-HF-3	EJ-SYS-MEDIUM-HF-3 vacuum pump with holder and integrated silencer	3330096
EJ-SYS-M-HV-2	EJ-SYS-MEDIUM-HV-2 vacuum pump with holder and integrated silencer	3330097
EJ-SYS-M-HV-3	EJ-SYS-MEDIUM-HV-3 vacuum pump with holder and integrated silencer	3330098

Vacuum pumps / EJ-SYS

EJ-SYS-LARGE

- Ideal for centralized applications
- Easy installation and positioning thanks to several mounting options
- Anodized aluminum body
- High suction flow rate, with low energy consumption
- G1/2" vacuum port
- Integrated silencer
- The three-stage cartridge offers a higher initial flow rate, ideal for high speed applications
- Available with two- and three-stage EJ-LARGE cartridge (EJ-LP, EJ-HF, EJ-HV)

Typical applications

- Particularly suitable for sealed applications, handling of glass, sheet metal, marble (EJ-HV)
- Handling of porous items, cardboard, wood and leaking surfaces (EJ-HF, EJ-LP)
- Rotary machines and cartoners



NEW



NEW



Application example



Technical features

Max feed pressure	0.7 MPa
Weight	225 ± 241 g
Material	PA, SS, Al, Nitrile (NBR)
Noise level	< 70 dB

Suction flow rate

Model	Feed pressure [MPa]	Air consumption [Nl/s]	Suction flow rate [Nl/s] at different vacuum levels [kPa]										Max vacuum [kPa]
			0	-10	-20	-30	-40	-50	-60	-70	-80	-90	
EJ-SYS-L-LP-2	0.4	2.6	2.8	2.5	2.1	1.5	1.1	0.66	0.36	0.26	0.08	–	-89
EJ-SYS-L-LP-3	0.4	2.6	5.7	2.5	2.1	1.5	1.1	0.66	0.36	0.26	0.08	–	-89
EJ-SYS-L-HF-2	0.6	1.7	3.2	3.0	2.5	1.7	0.89	0.62	0.51	0.31	–	–	-73
EJ-SYS-L-HF-3	0.6	1.7	5.9	3.5	2.5	1.7	0.89	0.62	0.51	0.31	–	–	-73
EJ-SYS-L-HV-2	0.5	1.93	2.6	2.4	1.7	1.3	0.70	0.55	0.40	0.31	0.15	0.02	-94
EJ-SYS-L-HV-3	0.5	1.93	6.0	3.7	2.1	1.9	0.79	0.55	0.40	0.31	0.15	0.02	-94

For technical specifications, regarding the suction flow rate and the air consumption at different pressures, please refer to the technical data sheets of the EJ-LARGE cartridges in the two- and three-stage versions

Evacuation time

Model	Feed pressure [MPa]	Air consumption [Nl/s]	Evacuation time [s/l] to reach different vacuum levels [kPa]										Max vacuum [kPa]
			-10	-20	-30	-40	-50	-60	-70	-80	-90		
EJ-SYS-L-LP-2	0.4	2.6	0.04	0.07	0.14	0.19	0.3	0.5	0.8	1.4	–	-89	
EJ-SYS-L-LP-3	0.4	2.6	0.02	0.07	0.12	0.2	0.3	0.5	0.8	1.4	–	-89	
EJ-SYS-L-HF-2	0.6	1.7	0.03	0.07	0.12	0.19	0.3	0.4	0.7	–	–	-73	
EJ-SYS-L-HF-3	0.6	1.7	0.02	0.05	0.10	0.19	0.3	0.4	0.7	–	–	-73	
EJ-SYS-L-HV-2	0.5	1.93	0.04	0.09	0.16	0.3	0.4	0.6	0.9	1.3	2.5	-94	
EJ-SYS-L-HV-3	0.5	1.93	0.02	0.06	0.10	0.2	0.3	0.4	0.7	1.1	2.4	-94	

For technical specifications regarding the evacuation time and the consumption at different pressures, please refer to the technical data sheets of the EJ-LARGE cartridges, in the two- and three-stage versions

Identification codes

Alphanumeric code	Description	Order code
EJ-SYS-L-LP-2	EJ-SYS-LARGE-LP-2 vacuum pump with holder and integrated silencer	3330100
EJ-SYS-L-LP-3	EJ-SYS-LARGE-LP-3 vacuum pump with holder and integrated silencer	3330101
EJ-SYS-L-HF-2	EJ-SYS-LARGE-HF-2 vacuum pump with holder and integrated silencer	3330102
EJ-SYS-L-HF-3	EJ-SYS-LARGE-HF-3 vacuum pump with holder and integrated silencer	3330103
EJ-SYS-L-HV-2	EJ-SYS-LARGE-HV-2 vacuum pump with holder and integrated silencer	3330104
EJ-SYS-L-HV-3	EJ-SYS-LARGE-HV-3 vacuum pump with holder and integrated silencer	3330105

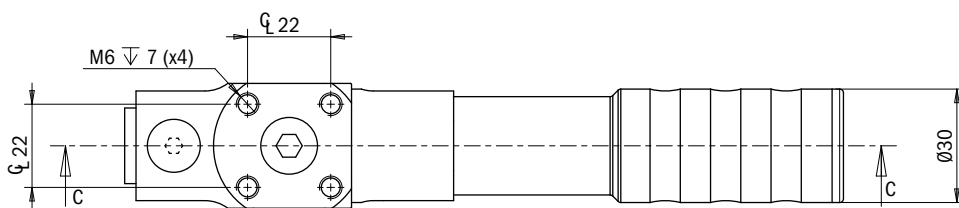
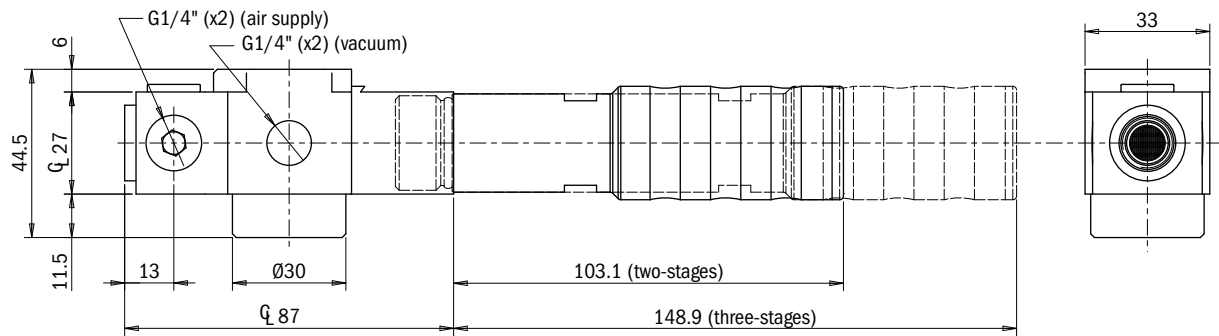
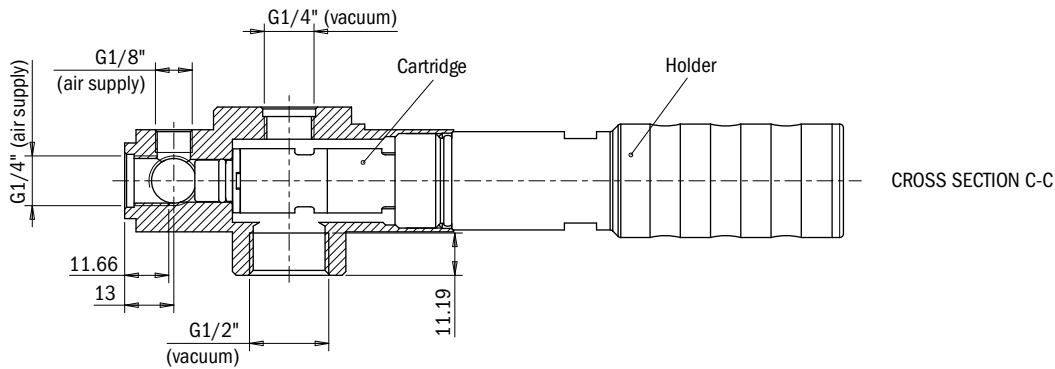

Identification codes

Alphanumeric code		Description	Order code
EJ-SYS-L-HF-2-H	NEW	EJ-SYS-LARGE-HF-2 vacuum pump with holder	3331102
EJ-SYS-L-HF-3-H	NEW	EJ-SYS-LARGE-HF-3 vacuum pump with holder	3331103
EJ-SYS-L-HV-2-H	NEW	EJ-SYS-LARGE-HV-2 vacuum pump with holder	3331104
EJ-SYS-L-HV-3-H	NEW	EJ-SYS-LARGE-HV-3 vacuum pump with holder	3331105



Click for Pricing & Add to Cart

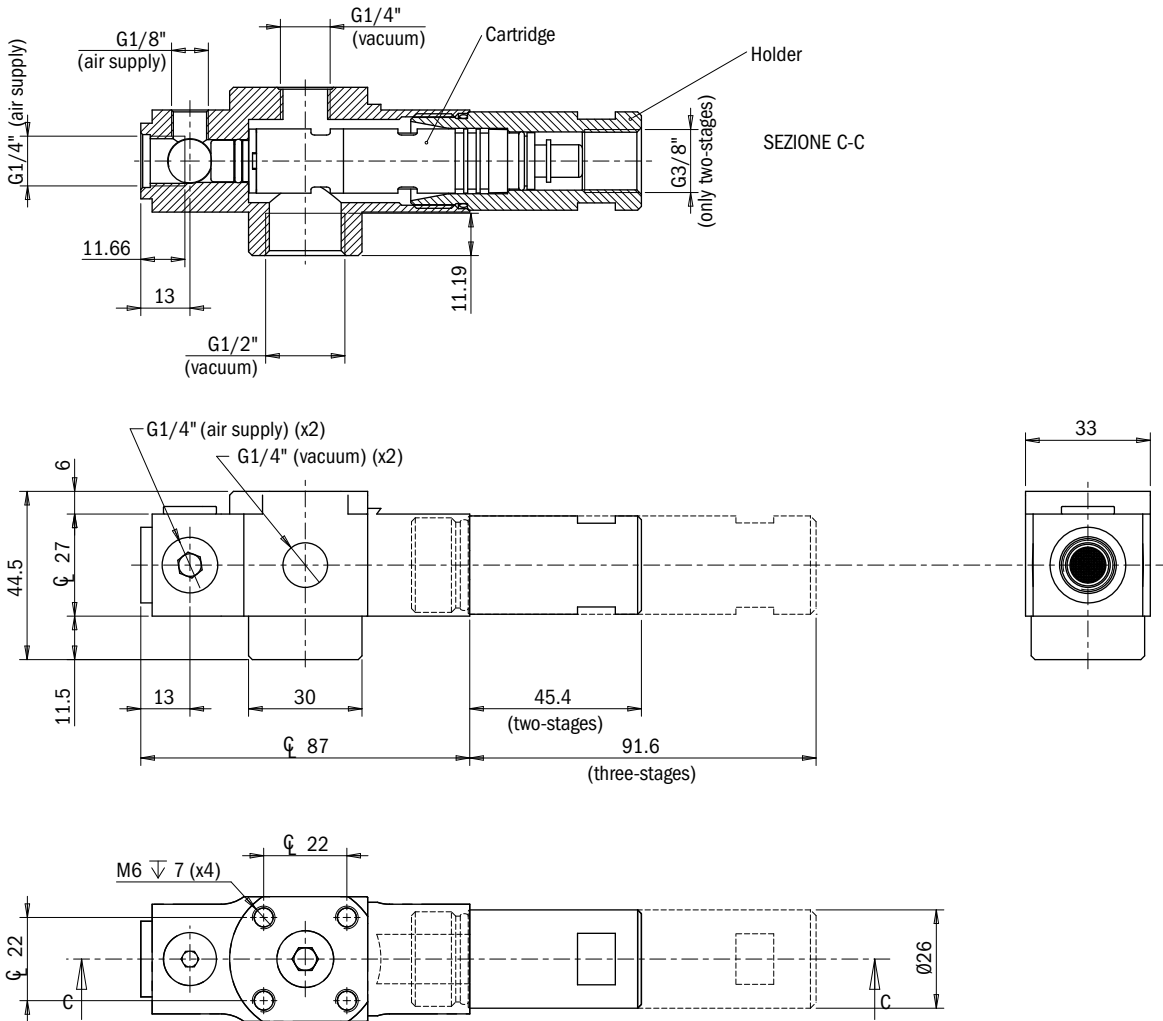

EJ-SLG-MEDIUM

- Ideal for decentralized applications
- Easy installation and positioning thanks to several mounting options
- Lightweight for direct integration on robot or on EOAT
- G3/8" vacuum port
- Integrated silencer
- Multiple vacuum connections
- Single supply connection
- Prearranged with VACSW-3N203-G (PNP) and VACSW-3M203-G (NPN) vacuum switches
- Available with two- and three-stage EJ-MEDIUM cartridge (EJ-LP, EJ-HF, EJ-HV)

Typical applications

- Where a vacuum pump with high suction flow rate and extremely low weights is required (cosmetic industry applications)
- Packaging machines, for the food and pharmaceutical sector
- Where low weights and compact dimensions are required (PKM-Delta Robot)



Application example

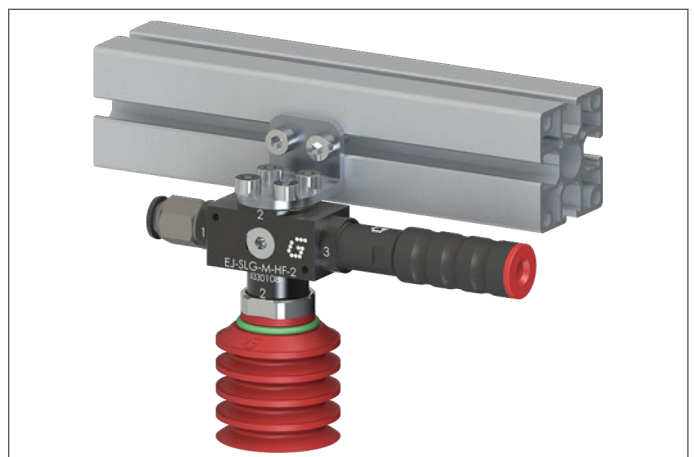

Technical features

Max feed pressure	0.7 MPa
Weight	46 ± 50 g
Material	PA, SS, POM, Nitrile (NBR)
Noise level	< 70 dB

Suction flow rate

Model	Feed pressure [MPa]	Air consumption [l/s]	Suction flow rate [l/s] at different vacuum levels [kPa]										Max vacuum [kPa]
			0	-10	-20	-30	-40	-50	-60	-70	-80	-90	
EJ-SLG-M-LP-2	0.4	0.55	0.67	0.61	0.53	0.38	0.23	0.12	0.09	0.06	0.02	–	-89
EJ-SLG-M-LP-3	0.4	0.55	1.5	0.71	0.53	0.38	0.23	0.12	0.09	0.06	0.02	–	-89
EJ-SLG-M-HF-2	0.6	0.43	0.78	0.68	0.52	0.31	0.21	0.15	0.10	0.08	–	–	-73
EJ-SLG-M-HF-3	0.6	0.43	1.35	0.75	0.55	0.31	0.21	0.15	0.10	0.08	–	–	-73
EJ-SLG-M-HV-2	0.5	0.47	0.76	0.63	0.54	0.32	0.17	0.15	0.11	0.07	0.05	0.01	-94
EJ-SLG-M-HV-3	0.5	0.47	1.47	0.78	0.54	0.32	0.17	0.15	0.11	0.07	0.05	0.01	-94

For technical specifications, regarding the suction flow rate and the air consumption at different pressures, please refer to the technical data sheets of the EJ-MEDIUM cartridges in the two- and three-stage versions

Evacuation time

Model	Feed pressure [MPa]	Air consumption [NI/s]	Evacuation time [s/l] to reach different vacuum levels [kPa]										Max vacuum [kPa]
			-10	-20	-30	-40	-50	-60	-70	-80	-90		
EJ-SLG-M-LP-2	0.4	0.55	0.17	0.33	0.55	0.9	1.5	2.4	3.7	7.1	—	-89	
EJ-SLG-M-LP-3	0.4	0.55	0.08	0.23	0.44	0.76	1.4	2.4	3.7	7.1	—	-89	
EJ-SLG-M-HF-2	0.6	0.43	0.13	0.30	0.54	0.9	1.5	2.3	3.2	—	—	-73	
EJ-SLG-M-HF-3	0.6	0.43	0.10	0.25	0.48	0.8	1.3	2.3	3.2	—	—	-73	
EJ-SLG-M-HV-2	0.5	0.47	0.14	0.32	0.55	1.0	1.6	2.4	3.5	5.1	8.7	-94	
EJ-SLG-M-HV-3	0.5	0.47	0.08	0.24	0.47	0.88	1.6	2.4	3.5	5.1	8.7	-94	

For technical specifications regarding the evacuation time and the consumption at different pressures, please refer to the technical data sheets of the EJ-MEDIUM cartridges, in the two- and three-stage versions

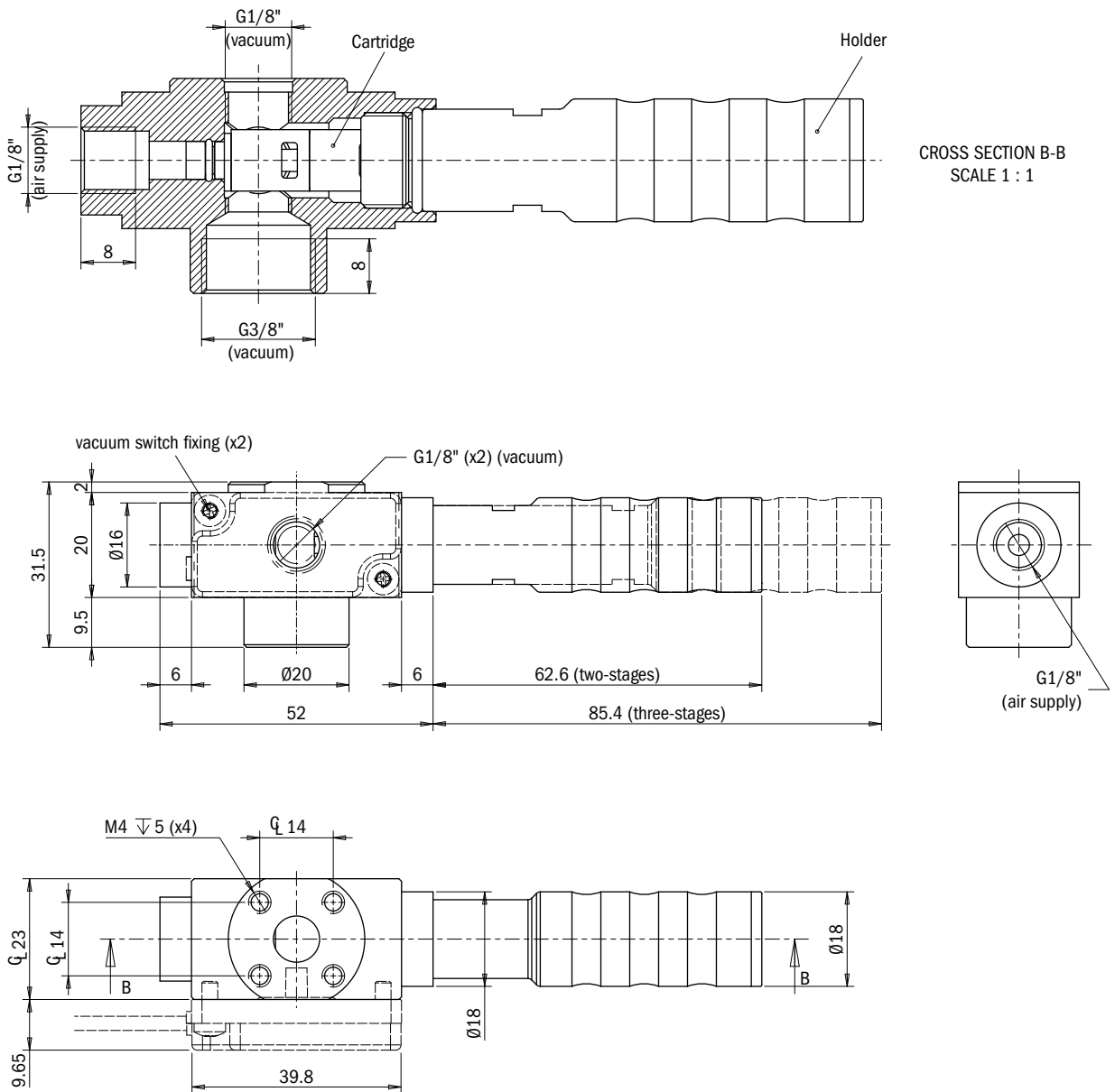

Identification codes

Alphanumeric code	Description	Order code
EJ-SLG-M-LP-2	EJ-SLG-MEDIUM-LP-2 vacuum pump with holder and integrated silencer	3330106
EJ-SLG-M-LP-3	EJ-SLG-MEDIUM-LP-3 vacuum pump with holder and integrated silencer	3330107
EJ-SLG-M-HF-2	EJ-SLG-MEDIUM-HF-2 vacuum pump with holder and integrated silencer	3330108
EJ-SLG-M-HF-3	EJ-SLG-MEDIUM-HF-3 vacuum pump with holder and integrated silencer	3330109
EJ-SLG-M-HV-2	EJ-SLG-MEDIUM-HV-2 vacuum pump with holder and integrated silencer	3330110
EJ-SLG-M-HV-3	EJ-SLG-MEDIUM-HV-3 vacuum pump with holder and integrated silencer	3330111

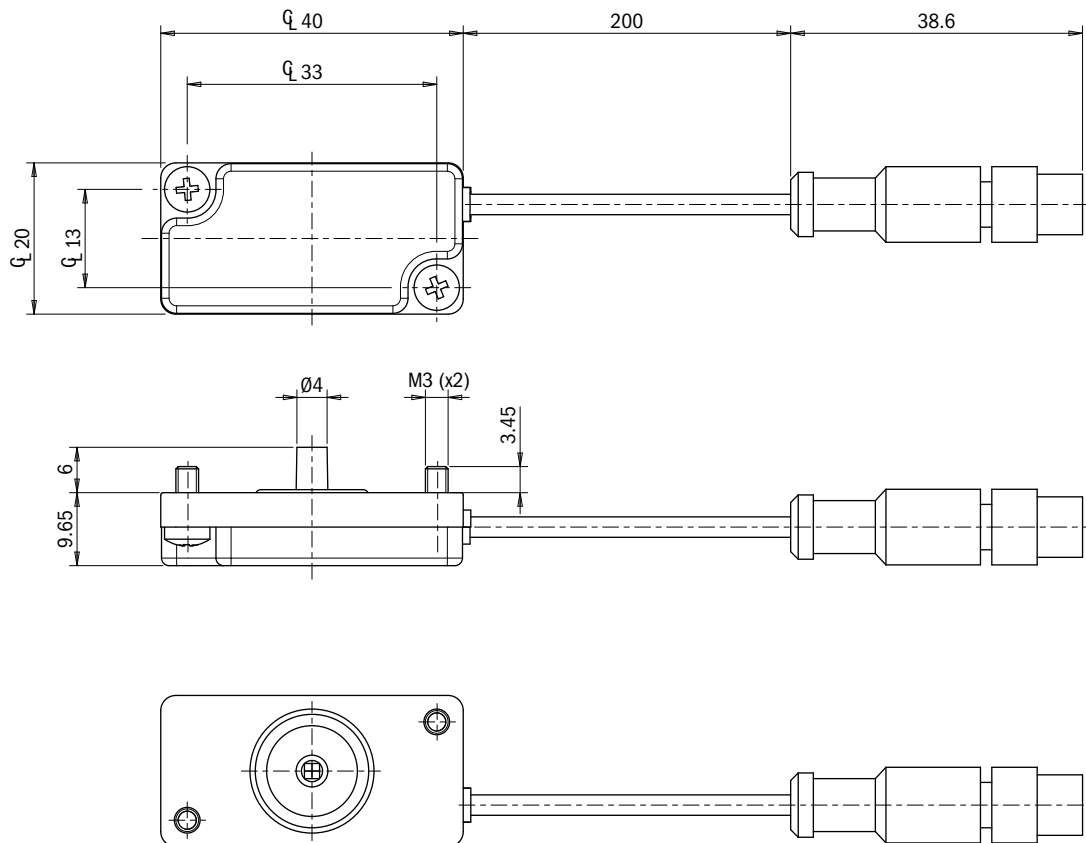

Identification codes

Alphanumeric code	Description	Order code
VACSW-30-3N203-G	Pre-set vacuum switch PNP -30 kPa with digital output, cable L= 30 cm with M8x1 3-LPn male connector	3030119
VACSW-50-3N203-G	Pre-set vacuum switch PNP -50 kPa with digital output, cable L= 30 cm with M8x1 3-LPn male connector	3030120
VACSW-70-3N203-G	Pre-set vacuum switch PNP -70 kPa with digital output, cable L= 30 cm with M8x1 3-LPn male connector	3030121
VACSW-30-3M203-G	Pre-set vacuum switch NPN -30 kPa with digital output, cable L= 30 cm with M8x1 3-LPn male connector	3030122
VACSW-50-3M203-G	Pre-set vacuum switch NPN -50 kPa with digital output, cable L= 30 cm with M8x1 3-LPn male connector	3030123
VACSW-70-3M203-G	Pre-set vacuum switch NPN -70 kPa with digital output, cable L= 30 cm with M8x1 3-LPn male connector	3030124

Vacuum pumps / EJ-SLG

EJ-SLG-LARGE

- Ideal for centralized applications
- Easy installation and positioning thanks to several mounting options
- G1/2" vacuum port
- Integrated silencer
- Multiple vacuum connections
- Prearranged with VACSW-3N203-G (PNP) and VACSW-3M203-G (NPN) vacuum switches
- Available with two- and three-stage EJ-LARGE cartridge (EJ-LP, EJ-HF, EJ-HV)

Typical applications

- Packaging machines, for the food and pharmaceutical sector
- Where low weights and compact dimensions are required (PKM-Delta Robot)
- Machines for the wood industry, where a high suction flow rate is required



NEW



NEW



Application example



Technical features

Max feed pressure	0.7 MPa
Weight	143 ± 159 g
Material	PA, SS, POM, Nitrile (NBR)
Noise level	< 70 dB

Suction flow rate

Model	Feed pressure [MPa]	Air consumption [Nl/s]	Suction flow rate [Nl/s] at different vacuum levels [kPa]										Max vacuum [kPa]
			0	-10	-20	-30	-40	-50	-60	-70	-80	-90	
EJ-SLG-L-LP-2	0.4	2.6	2.8	2.5	2.1	1.5	1.1	0.66	0.36	0.26	0.08	–	-89
EJ-SLG-L-LP-3	0.4	2.6	5.7	2.5	2.1	1.5	1.1	0.66	0.36	0.26	0.08	–	-89
EJ-SLG-L-HF-2	0.6	1.7	3.2	3.0	2.5	1.7	0.89	0.62	0.51	0.31	–	–	-73
EJ-SLG-L-HF-3	0.6	1.7	5.9	3.5	2.5	1.7	0.89	0.62	0.51	0.31	–	–	-73
EJ-SLG-L-HV-2	0.5	1.93	2.6	2.4	1.7	1.3	0.70	0.55	0.40	0.31	0.15	0.02	-94
EJ-SLG-L-HV-3	0.5	1.93	6.0	3.7	2.1	1.9	0.79	0.55	0.40	0.31	0.15	0.02	-94

For technical specifications, regarding the suction flow rate and the air consumption at different pressures, please refer to the technical data sheets of the EJ-LARGE cartridges in the two- and three-stage versions

Evacuation time

Model	Feed pressure [MPa]	Air consumption [Nl/s]	Evacuation time [s/l] to reach different vacuum levels [kPa]									Max vacuum [kPa]
			-10	-20	-30	-40	-50	-60	-70	-80	-90	
EJ-SLG-L-LP-2	0.4	2.6	0.04	0.07	0.14	0.19	0.3	0.5	0.8	1.4	–	-89
EJ-SLG-L-LP-3	0.4	2.6	0.02	0.07	0.12	0.2	0.3	0.5	0.8	1.4	–	-89
EJ-SLG-L-HF-2	0.6	1.7	0.03	0.07	0.12	0.19	0.3	0.4	0.7	–	–	-73
EJ-SLG-L-HF-3	0.6	1.7	0.02	0.05	0.10	0.19	0.3	0.4	0.7	–	–	-73
EJ-SLG-L-HV-2	0.5	1.93	0.04	0.09	0.16	0.3	0.4	0.6	0.9	1.3	2.5	-94
EJ-SLG-L-HV-3	0.5	1.93	0.02	0.06	0.10	0.2	0.3	0.4	0.7	1.1	2.4	-94

For technical specifications regarding the evacuation time and the consumption at different pressures, please refer to the technical data sheets of the EJ-LARGE cartridges, in the two- and three-stage versions

Identification codes

Alphanumeric code	Description	Order code
EJ-SLG-L-LP-2	EJ-SLG-LARGE-LP-2 vacuum pump with holder and integrated silencer	3330113
EJ-SLG-L-LP-3	EJ-SLG-LARGE-LP-3 vacuum pump with holder and integrated silencer	3330114
EJ-SLG-L-HF-2	EJ-SLG-LARGE-HF-2 vacuum pump with holder and integrated silencer	3330115
EJ-SLG-L-HF-3	EJ-SLG-LARGE-HF-3 vacuum pump with holder and integrated silencer	3330116
EJ-SLG-L-HV-2	EJ-SLG-LARGE-HV-2 vacuum pump with holder and integrated silencer	3330117
EJ-SLG-L-HV-3	EJ-SLG-LARGE-HV-3 vacuum pump with holder and integrated silencer	3330118

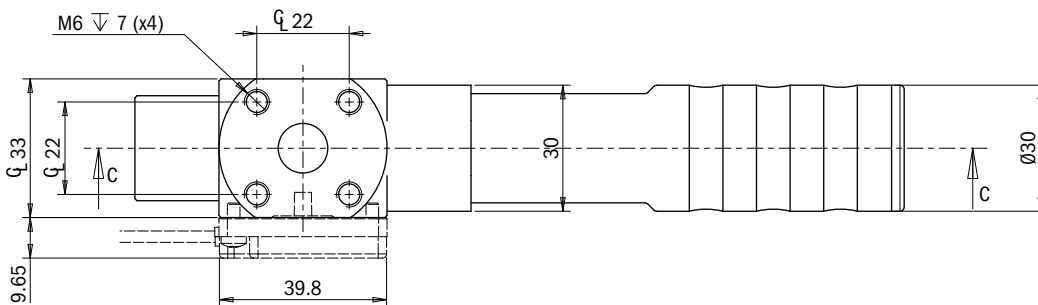
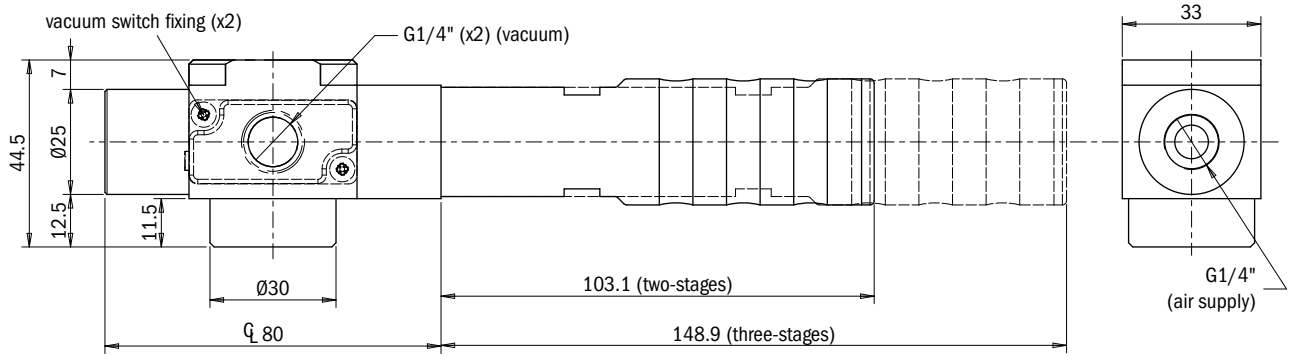
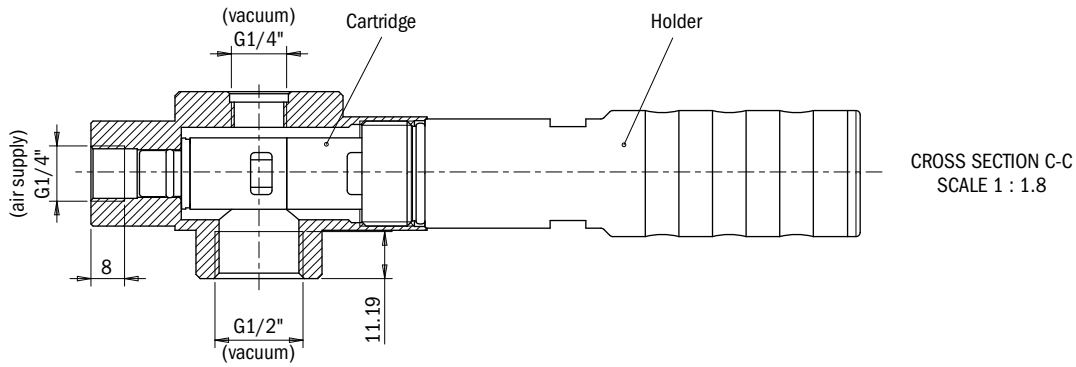

Identification codes

Alphanumeric code		Description	Order code
EJ-SLG-L-HF-2-H	NEW	EJ-SLG-LARGE-HF-2 vacuum pump with holder	3331115
EJ-SLG-L-HF-3-H	NEW	EJ-SLG-LARGE-HF-3 vacuum pump with holder	3331116

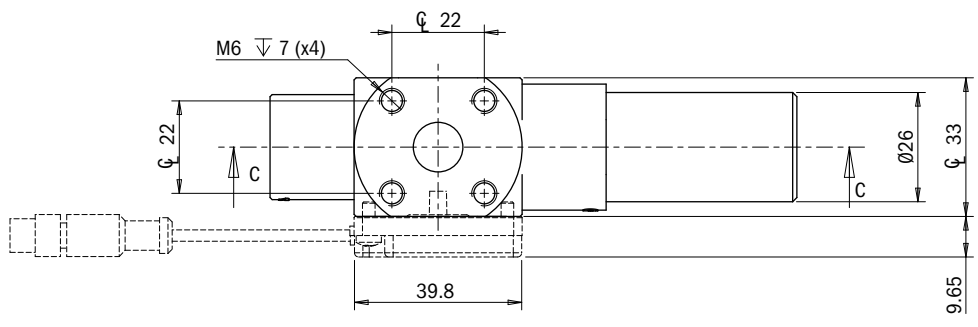
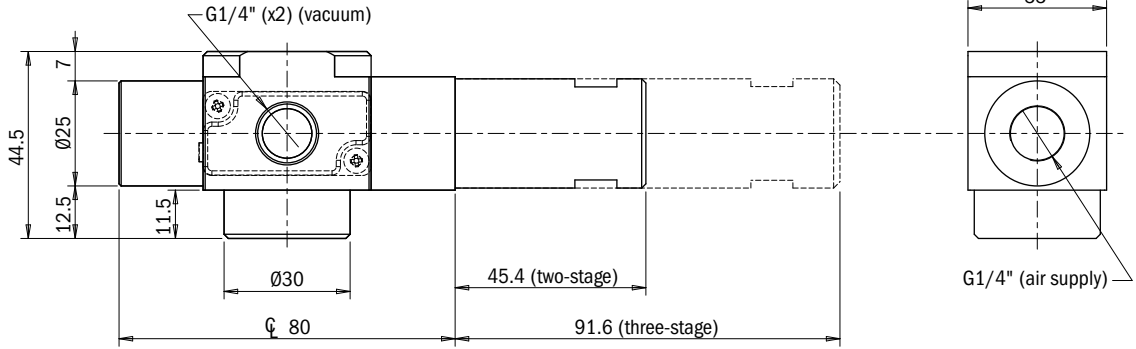
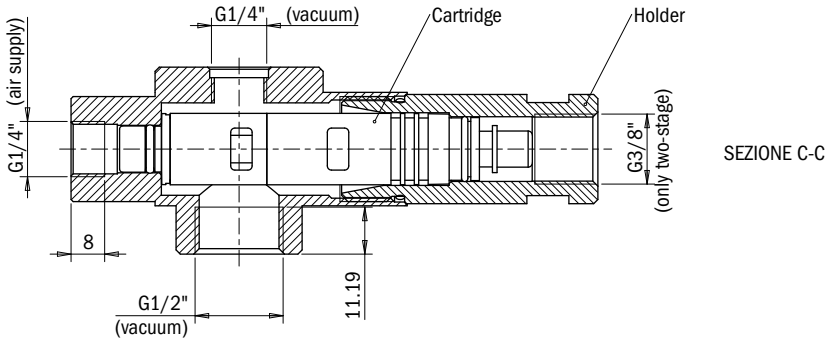

Introduction

Vacuum theory

Suction cups

Vacuum pumps

Customised solutions

Suspensions

System accessories

Identification codes

Alphanumeric code	Description	Order code
VACSW-30-3N203-G	Pre-set vacuum switch PNP -30 kPa with digital output, cable L= 30 cm with M8x1 3-LPn male connector	3030119
VACSW-50-3N203-G	Pre-set vacuum switch PNP -50 kPa with digital output, cable L= 30 cm with M8x1 3-LPn male connector	3030120
VACSW-70-3N203-G	Pre-set vacuum switch PNP -70 kPa with digital output, cable L= 30 cm with M8x1 3-LPn male connector	3030121
VACSW-30-3M203-G	Pre-set vacuum switch NPN -30 kPa with digital output, cable L= 30 cm with M8x1 3-LPn male connector	3030122
VACSW-50-3M203-G	Pre-set vacuum switch NPN -50 kPa with digital output, cable L= 30 cm with M8x1 3-LPn male connector	3030123
VACSW-70-3M203-G	Pre-set vacuum switch NPN -70 kPa with digital output, cable L= 30 cm with M8x1 3-LPn male connector	3030124

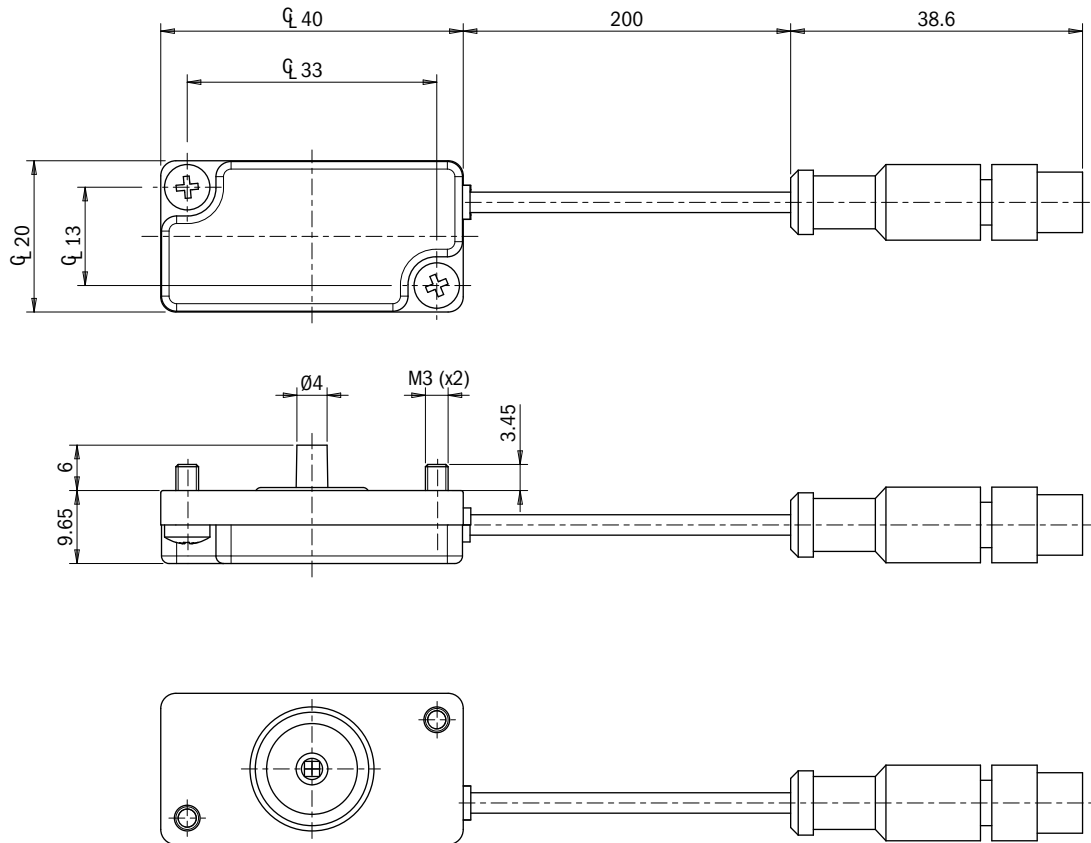

Vacuum pumps / EJ-ATM

EJ-ATM-LINE-SMALLX2-LP-2

- Restores the atmospheric pressure inside the gripping device to enable the quick release of the product
- Suitable for sealed applications to reduce cycle time
- Available with Gimatic's integrated vacuum switch, pre-set (-30, -50 and -70 kPa), in the PNP and NPN versions
- Vacuum ports, in-line or L-shaped
- A single 3/2 valve controls the vacuum pump and the ATM release device
- Anodized aluminum manifold
- Multiple G1/8" vacuum ports
- Available with two two-stage EJ-SMALL cartridges (EJ-LP), low feed pressure

Typical applications

- Robotic cells for handling parts in transformation processes, for instance when serving bending machines, sheet metal forming presses and bending processes
- Glass handling machines
- Packaging machines, for the food and pharmaceutical sector



Application example



Technical features

Max feed pressure	0.7 MPa
Weight	66.5 + 73.5 g
Material	PA, SS, Al, Nitrile (NBR)
Noise level	< 70 dB

Suction flow rate

Model	Feed pressure [MPa]	Air consumption [NI/s]	Suction flow rate [NI/s] at different vacuum levels [kPa]											Max vacuum [kPa]
			0	-10	-20	-30	-40	-50	-60	-70	-80	-90		
EJ-ATM-LINE-SX2-LP-2	0.22	0.34	0.5	0.36	0.16	0.1	0.08	0.05	0.036	0.0106	–	–	-82	

For technical specifications regarding the suction flow rate and the air consumption at different pressures, refer to the technical data sheets of the two-stage EJ-SMALL-LP cartridges and multiply by two the values reported at the different vacuum levels

Evacuation time

Model	Feed pressure [MPa]	Air consumption [NI/s]	Evacuation time [s/l] to reach different vacuum levels [kPa]										Max vacuum [kPa]
			-10	-20	-30	-40	-50	-60	-70	-80	-90		
EJ-ATM-LINE-SX2-LP-2	0.22	0.34	0.23	0.61	1.38	2.5	4.03	6.35	10.65	29.5	–	-82	

For technical specifications regarding the evacuation time and the consumption at different pressures refer to the technical data sheets of the EJ-SMALL-LP cartridges and divide by two the reported values

Identification codes

Alphanumeric code	Description	Order code
EJ-ATM-LINE-SX2-LP-2	EJ-ATM-LINE-SMALLX2-LP-2 vacuum pump with holder	3030125
EJ-ATM-LINE-SX2-LP-2-VSW-30-P	EJ-ATM-LINE-SMALLX2-LP-2 vacuum pump with holder, pre-set vacuum switch PNP -30 kPa	3030126
EJ-ATM-LINE-SX2-LP-2-VSW-50-P	EJ-ATM-LINE-SMALLX2-LP-2 vacuum pump with holder, pre-set vacuum switch PNP -50 kPa	3030127
EJ-ATM-LINE-SX2-LP-2-VSW-70-P	EJ-ATM-LINE-SMALLX2-LP-2 vacuum pump with holder, pre-set vacuum switch PNP -70 kPa	3030128
EJ-ATM-LINE-SX2-LP-2-VSW-30-N	EJ-ATM-LINE-SMALLX2-LP-2 vacuum pump with holder, pre-set vacuum switch NPN -30 kPa	3030129
EJ-ATM-LINE-SX2-LP-2-VSW-50-N	EJ-ATM-LINE-SMALLX2-LP-2 vacuum pump with holder, pre-set vacuum switch NPN -50 kPa	3030130
EJ-ATM-LINE-SX2-LP-2-VSW-70-N	EJ-ATM-LINE-SMALLX2-LP-2 vacuum pump with holder, pre-set vacuum switch NPN -70 kPa	3030131

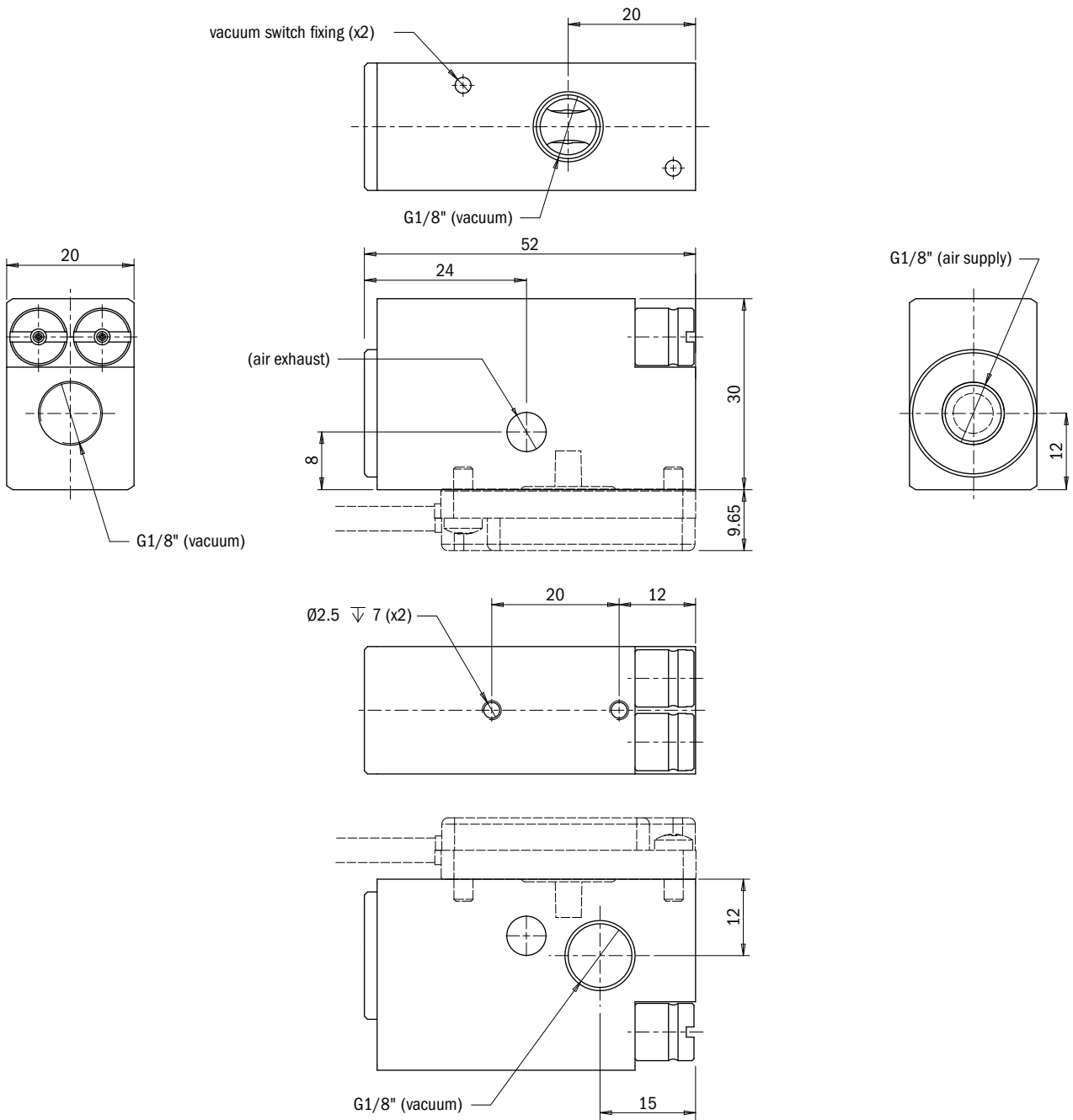

Vacuum pumps / EJ-ATM

EJ-ATM-MEDIUM-HV-2

- Restores the atmospheric pressure inside the gripping device to enable the quick release of the product
- Suitable for sealed applications to reduce cycle time
- G3/8" vacuum port
- Integrated silencer
- Multiple vacuum connections
- Available with Gimatic's integrated vacuum switch, pre-set (-30, -50 and -70 kPa), in the PNP and NPN versions
- A single 3/2 valve controls the vacuum pump and the ATM release device
- Anodized aluminum manifold
- Available with the two-stage EJ-MEDIUM cartridge (EJ-HV)

Typical applications

- Robotic cells for handling parts in transformation processes, for instance when serving bending machines, sheet metal forming presses and bending processes
- Glass handling machines
- Packaging machines, for the food and pharmaceutical sector



Application example



Technical features

Max feed pressure	0.7 MPa
Weight	213 ± 220 g
Material	PA, SS, POM, Nitrile (NBR)
Noise level	< 70 dB

Suction flow rate

Model	Feed pressure [MPa]	Air consumption [l/s]	Suction flow rate [l/s] at different vacuum levels [kPa]										Max vacuum [kPa]
			0	-10	-20	-30	-40	-50	-60	-70	-80	-90	
EJ-ATM-M-HV-2	0.5	0.47	0.76	0.63	0.54	0.32	0.17	0.15	0.11	0.07	0.05	0.01	-94

For technical specifications, regarding the suction flow rate and the air consumption at different pressures, please refer to the technical data sheets of the two-stage EJ-MEDIUM-HV cartridges

Evacuation time

Model	Feed pressure [MPa]	Air consumption [l/s]	Evacuation time [s/l] to reach different vacuum levels [kPa]									Max vacuum [kPa]
			-10	-20	-30	-40	-50	-60	-70	-80	-90	
EJ-ATM-M-HV-2	0.5	0.47	0.14	0.32	0.55	1.0	1.6	2.4	3.5	5.1	8.7	-94

For technical specifications regarding evacuation time and consumption at different pressures, please refer to the technical data sheets of the two-stage EJ-MEDIUM-HV cartridges

Identification codes		
Alphanumeric code	Description	Order code
EJ-ATM-M-HV-2	EJ-ATM-MEDIUM-HV-2 vacuum pump with holder and integrated silencer	3100001
EJ-ATM-M-HV-2-VSW-30-P	EJ-ATM-MEDIUM-HV-2 vacuum pump with holder and integrated silencer, pre-set vacuum switch PNP -30 kPa	3100002
EJ-ATM-M-HV-2-VSW-50-P	EJ-ATM-MEDIUM-HV-2 vacuum pump with holder and integrated silencer, pre-set vacuum switch PNP -50 kPa	3100003
EJ-ATM-M-HV-2-VSW-70-P	EJ-ATM-MEDIUM-HV-2 vacuum pump with holder and integrated silencer, pre-set vacuum switch PNP -70 kPa	3100004
EJ-ATM-M-HV-2-VSW-30-N	EJ-ATM-MEDIUM-HV-2 vacuum pump with holder and integrated silencer, pre-set vacuum switch NPN -30 kPa	3100005
EJ-ATM-M-HV-2-VSW-50-N	EJ-ATM-MEDIUM-HV-2 vacuum pump with holder and integrated silencer, pre-set vacuum switch NPN -50 kPa	3100006
EJ-ATM-M-HV-2-VSW-70-N	EJ-ATM-MEDIUM-HV-2 vacuum pump with holder and integrated silencer, pre-set vacuum switch NPN -70 kPa	3100007

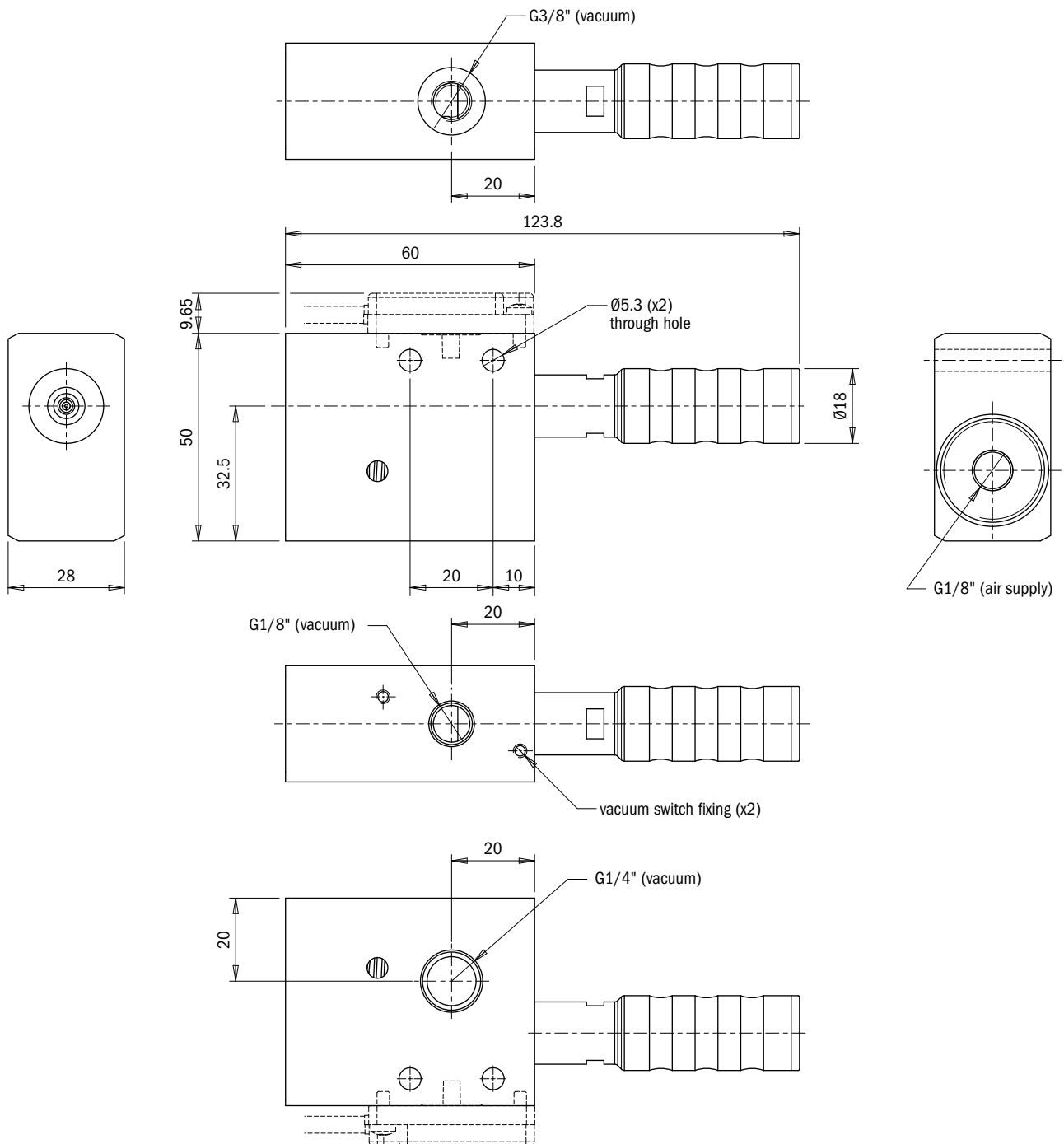

Vacuum pumps / EJ-BLOWOFF

EJ-BLOWOFF-MEDIUM-HF-2

- Ideal for applications in dusty environments
- Adjustable blow-off for quick release and cleaning of the EJ cartridge
- Tank capacity 10 cm³
- Available with Gimatic's integrated vacuum switch, pre-set (-30, -50 and -70 kPa), in the PNP and NPN versions
- No additional valves are required, as only one 3/2 valve controls both the vacuum pump and the blow-off function
- Integrated silencer
- Anodized aluminum manifold
- Available with one two-stage EJ-MEDIUM cartridge (EJ-HF), high suction flow rate and low energy consumption

Typical applications

- Packaging machines, for the food and pharmaceutical sector
- Handling of cosmetic products
- Pick-up of porous items (cardboard, wooden sheets)



Application example



Technical features

Max feed pressure	0.7 MPa
Weight	200 ± 207 g
Material	PA, SS, POM, Al, Nitrile (NBR)
Noise level	< 70 dB

Suction flow rate

Model	Feed pressure [MPa]	Air consumption [l/s]	Suction flow rate [l/s] at different vacuum levels [kPa]										Max vacuum [kPa]
			0	-10	-20	-30	-40	-50	-60	-70	-80	-90	
EJ-BLOWOFF-M-HF-2	0.6	0.43	0.78	0.68	0.52	0.31	0.21	0.15	0.10	0.08	–	–	-73

For technical specifications, regarding the suction flow rate and the air consumption at different pressures, please refer to the technical data sheets of the EJ-MEDIUM-HF cartridges in the two-stage version

Evacuation time

Model	Feed pressure [MPa]	Air consumption [l/s]	Evacuation time [s/l] to reach different vacuum levels [kPa]									Max vacuum [kPa]
			-10	-20	-30	-40	-50	-60	-70	-80	-90	
EJ-BLOWOFF-M-HF-2	0.6	0.43	0.13	0.30	0.54	0.9	1.5	2.3	3.2	–	–	-73

For technical specifications regarding the evacuation time and the consumption at different pressures, please refer to the technical data sheets of the EJ-MEDIUM cartridges, in the two-stage version

Identification codes		
Alphanumeric code	Description	Order code
EJ-BLOWOFF-M-HF-2	EJ-BLOWOFF-MEDIUM-HF-2 vacuum pump with holder and integrated silencer	3030132
EJ-BLOWOFF-M-HF-2-VSW-30-P	EJ-BLOWOFF-MEDIUM-HF-2 vacuum pump with holder and integrated silencer, pre-set vacuum switch PNP -30 kPa	3030133
EJ-BLOWOFF-M-HF-2-VSW-50-P	EJ-BLOWOFF-MEDIUM-HF-2 vacuum pump with holder and integrated silencer, pre-set vacuum switch PNP -50 kPa	3030134
EJ-BLOWOFF-M-HF-2-VSW-70-P	EJ-BLOWOFF-MEDIUM-HF-2 vacuum pump with holder and integrated silencer, pre-set vacuum switch PNP -70 kPa	3030135
EJ-BLOWOFF-M-HF-2-VSW-30-N	EJ-BLOWOFF-MEDIUM-HF-2 vacuum pump with holder and integrated silencer, pre-set vacuum switch NPN -30 kPa	3030136
EJ-BLOWOFF-M-HF-2-VSW-50-N	EJ-BLOWOFF-MEDIUM-HF-2 vacuum pump with holder and integrated silencer, pre-set vacuum switch NPN -50 kPa	3030137
EJ-BLOWOFF-M-HF-2-VSW-70-N	EJ-BLOWOFF-MEDIUM-HF-2 vacuum pump with holder and integrated silencer, pre-set vacuum switch NPN -70 kPa	3030138

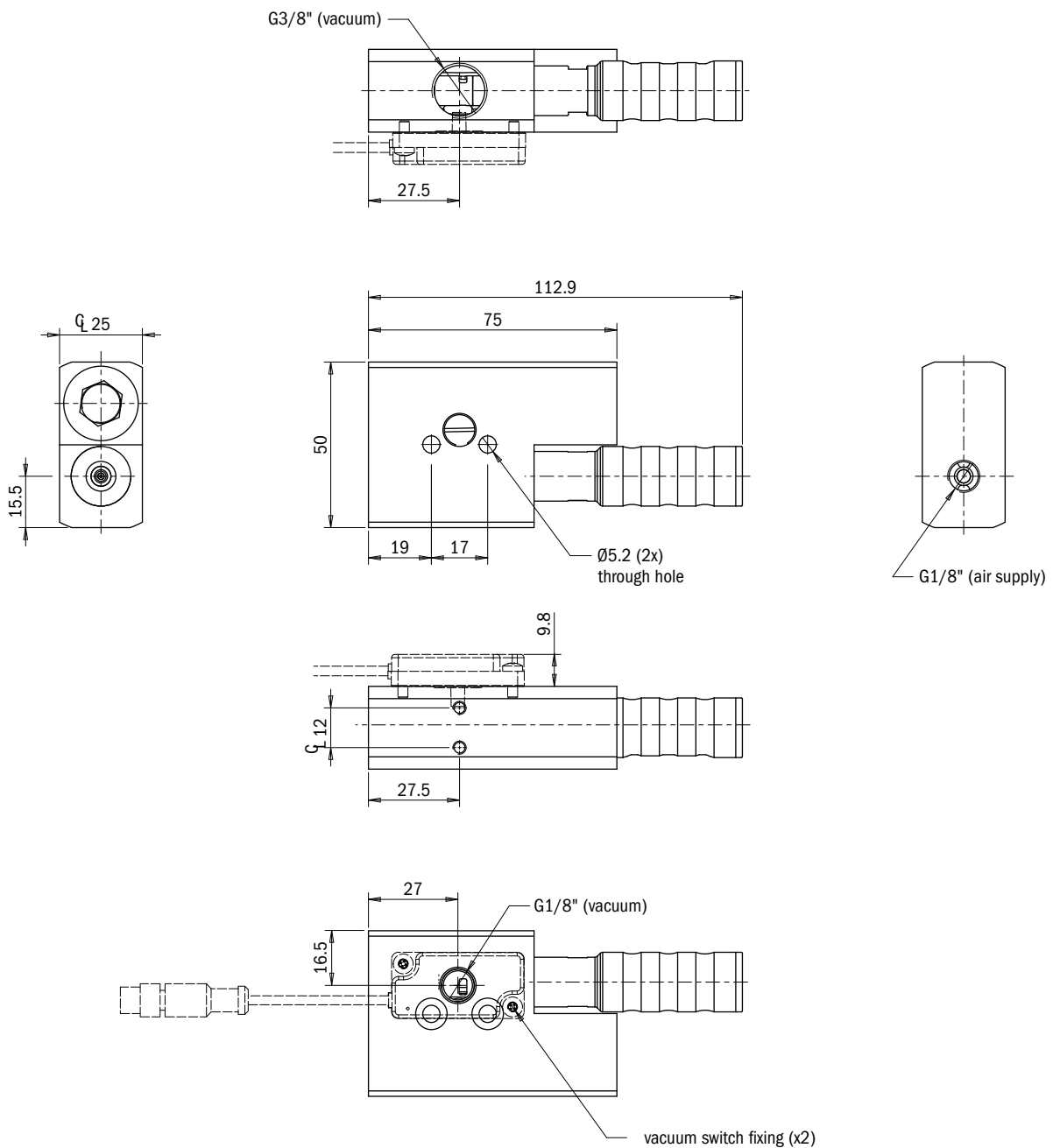

Vacuum pumps / EJ-BLOWOFF

EJ-BLOWOFF-MEDIUMX2-HF-2

- Ideal for applications in dusty environments
- Adjustable blow-off for quick release and cleaning of the EJ cartridge
- Tank capacity 15 cm³
- G3/8" vacuum port
- Available with Gimatic's integrated vacuum switch, pre-set (-30, -50 and -70 kPa), in the PNP and NPN versions
- Multiple vacuum connections
- No additional valves are required, as only one 3/2 valve controls both the vacuum pump and the blow-off function
- Integrated silencer
- Manifold in POM
- Available with two two-stage EJ-MEDIUM cartridges (EJ-HF), high suction flow rate and low energy consumption

Typical applications

- Packaging machines, for the food and pharmaceutical sector
- Handling of cosmetic products
- Pick-up of porous items (cardboard, wooden sheets)



Application example

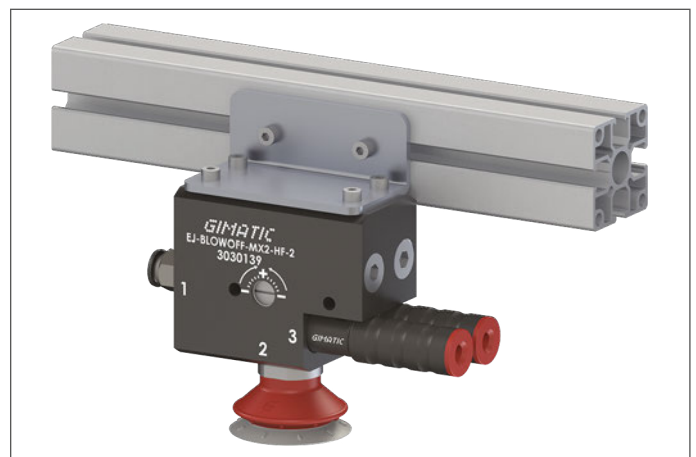

Technical features

Max feed pressure	0.7 MPa
Weight	256 ± 263 g
Material	PA, SS, Al, POM, Nitrile (NBR)
Noise level	< 70 dB

Suction flow rate

Model	Feed pressure [MPa]	Air consumption [l/s]	Suction flow rate [l/s] at different vacuum levels [kPa]										Max vacuum [kPa]
			0	-10	-20	-30	-40	-50	-60	-70	-80	-90	
EJ-BLOWOFF-MX2-HF-2	0.6	0.86	1.56	1.36	1.04	0.62	0.42	0.30	0.20	0.16	–	–	-73

For technical specifications regarding the suction flow rate and the air consumption at different pressures, refer to the technical data sheets of the two-stage EJ-MEDIUM-HF cartridges and multiply by 2 the values reported at the different vacuum levels

Evacuation time

Model	Feed pressure [MPa]	Air consumption [l/s]	Evacuation time [s/l] to reach different vacuum levels [kPa]									Max vacuum [kPa]
			-10	-20	-30	-40	-50	-60	-70	-80	-90	
EJ-BLOWOFF-MX2-HF-2	0.6	0.86	0.065	0.15	0.27	0.45	0.75	1.15	1.6	–	–	-73

For technical specifications regarding the evacuation time and the consumption at different pressures refer to the technical data sheets of the two-stage EJ-MEDIUM-HF cartridges and divide by 2 the reported values

Identification codes		
Alphanumeric code	Description	Order code
EJ-BLOWOFF-MX2-HF-2	EJ-BLOWOFF-MEDIUMX2-HF-2 vacuum pump with holder and integrated silencer	3030139
EJ-BLOWOFF-MX2-HF-2-VSW-30-P	EJ-BLOWOFF-MEDIUMX2-HF-2 vacuum pump with holder and integrated silencer, pre-set vacuum switch PNP -30 kPa	3030140
EJ-BLOWOFF-MX2-HF-2-VSW-50-P	EJ-BLOWOFF-MEDIUMX2-HF-2 vacuum pump with holder and integrated silencer, pre-set vacuum switch PNP -50 kPa	3030141
EJ-BLOWOFF-MX2-HF-2-VSW-70-P	EJ-BLOWOFF-MEDIUMX2-HF-2 vacuum pump with holder and integrated silencer, pre-set vacuum switch PNP -70 kPa	3030142
EJ-BLOWOFF-MX2-HF-2-VSW-30-N	EJ-BLOWOFF-MEDIUMX2-HF-2 vacuum pump with holder and integrated silencer, pre-set vacuum switch NPN -30 kPa	3030143
EJ-BLOWOFF-MX2-HF-2-VSW-50-N	EJ-BLOWOFF-MEDIUMX2-HF-2 vacuum pump with holder and integrated silencer, pre-set vacuum switch NPN -50 kPa	3030144
EJ-BLOWOFF-MX2-HF-2-VSW-70-N	EJ-BLOWOFF-MEDIUMX2-HF-2 vacuum pump with holder and integrated silencer, pre-set vacuum switch NPN -70 kPa	3030145

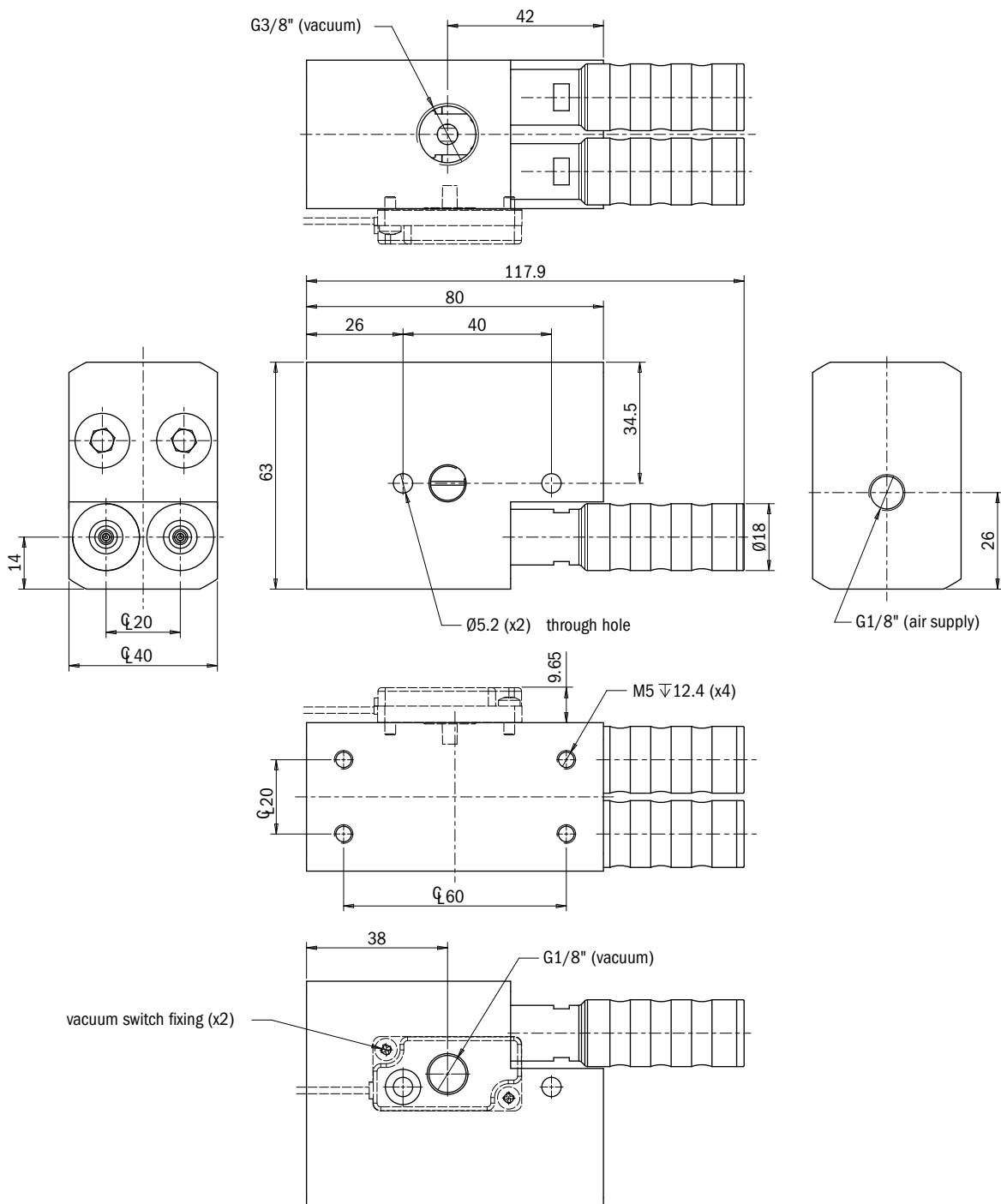

Vacuum pumps / EJ-BLOWOFF

EJ-BLOWOFF-LARGE

- Ideal for centralized applications
- Easy installation and positioning thanks to several mounting options
- Ideal for applications in dusty environments
- Adjustable blow-off for quick release and cleaning of the EJ-LARGE cartridge
- Tank capacity 25 cm³
- G1/2" vacuum port
- Integrated silencer
- Multiple vacuum connections
- Prearranged with VACSW-3N203-G B (PNP) and VACSW-3M203-G (NPN) vacuum switches
- Manifold in POM
- Available with two- and three-stage EJ-LARGE cartridges (EJ-HF - EJ-HV)

Typical applications

- Packaging machines, for the food and pharmaceutical sector
- Machines for the wood industry and for handling porous products
- Machines for the cosmetic industry



Application example



Technical features

Max feed pressure	0.7 MPa
Weight	305 ± 320 g
Material	PA, SS, POM, Al, Nitrile (NBR)
Noise level	< 70 dB

Suction flow rate

Model	Feed pressure [MPa]	Air consumption [NI/s]	Suction flow rate [NI/s] at different vacuum levels [kPa]										Max vacuum [kPa]
			0	-10	-20	-30	-40	-50	-60	-70	-80	-90	
EJ-BLOWOFF-L-HF-2	0.6	1.7	3.2	3.0	2.5	1.7	0.89	0.62	0.51	0.31	–	–	-73
EJ-BLOWOFF-L-HF-3	0.6	1.7	5.9	3.5	2.5	1.7	0.89	0.62	0.51	0.31	–	–	-73
EJ-BLOWOFF-L-HV-2	0.5	1.93	2.6	2.4	1.7	1.3	0.70	0.55	0.40	0.31	0.15	0.02	-94
EJ-BLOWOFF-L-HV-3	0.5	1.93	6.0	3.7	2.1	1.9	0.79	0.55	0.40	0.31	0.15	0.02	-94

For technical specifications, regarding the suction flow rate and the air consumption at different pressures, please refer to the technical data sheets of the EJ-LARGE cartridges in the two- and three-stage versions

Evacuation time

Model	Feed pressure [MPa]	Air consumption [l/s]	Evacuation time [s/l] to reach different vacuum levels [kPa]										Max vacuum [kPa]
			-10	-20	-30	-40	-50	-60	-70	-80	-90		
EJ-BLOWOFF-L-HF-2	0.6	1.7	0.03	0.07	0.12	0.19	0.3	0.4	0.7	—	—	-73	
EJ-BLOWOFF-L-HF-3	0.6	1.7	0.02	0.05	0.10	0.19	0.3	0.4	0.7	—	—	-73	
EJ-BLOWOFF-L-HV-2	0.5	1.93	0.04	0.09	0.16	0.3	0.4	0.6	0.9	1.3	2.5	-94	
EJ-BLOWOFF-L-HV-3	0.5	1.93	0.02	0.06	0.10	0.2	0.3	0.4	0.7	1.1	2.4	-94	

For technical specifications regarding the evacuation time and the consumption at different pressures, please refer to the technical data sheets of the EJ-LARGE cartridges, in the two- and three-stage versions

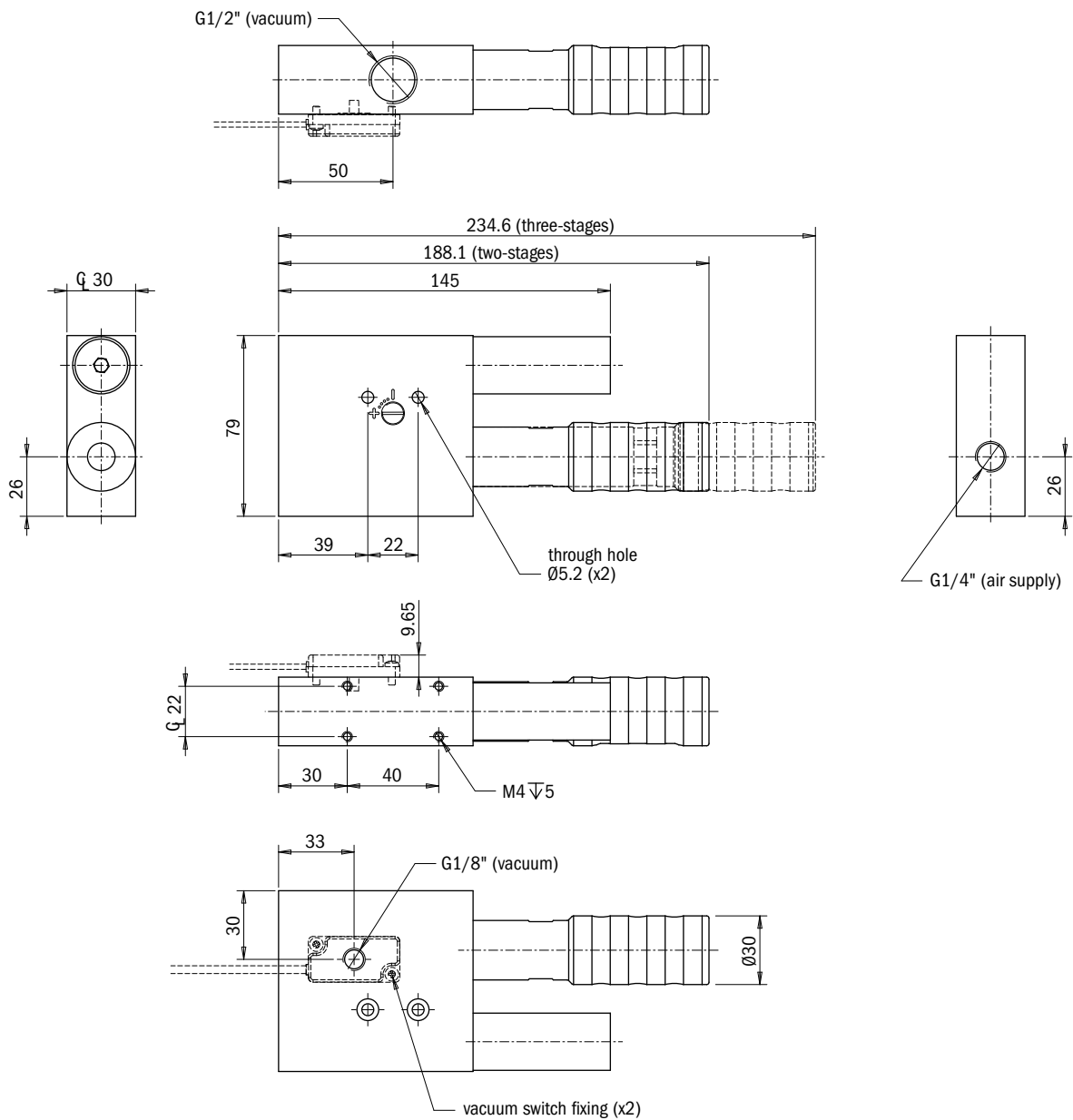

Identification codes

Alphanumeric code	Description	Order code
EJ-BLOWOFF-L-HF-2	EJ-BLOWOFF-LARGE-HF-2 vacuum pump with holder and integrated silencer, G1/2" vacuum port	3030191
EJ-BLOWOFF-L-HF-3	EJ-BLOWOFF-LARGE-HF-3 vacuum pump with holder and integrated silencer, G1/2" vacuum port	3030192
EJ-BLOWOFF-L-HV-2	EJ-BLOWOFF-LARGE-HV-2 vacuum pump with holder and integrated silencer, G1/2" vacuum port	3030193
EJ-BLOWOFF-L-HV-3	EJ-BLOWOFF-LARGE-HV-3 vacuum pump with holder and integrated silencer, G1/2" vacuum port	3030194

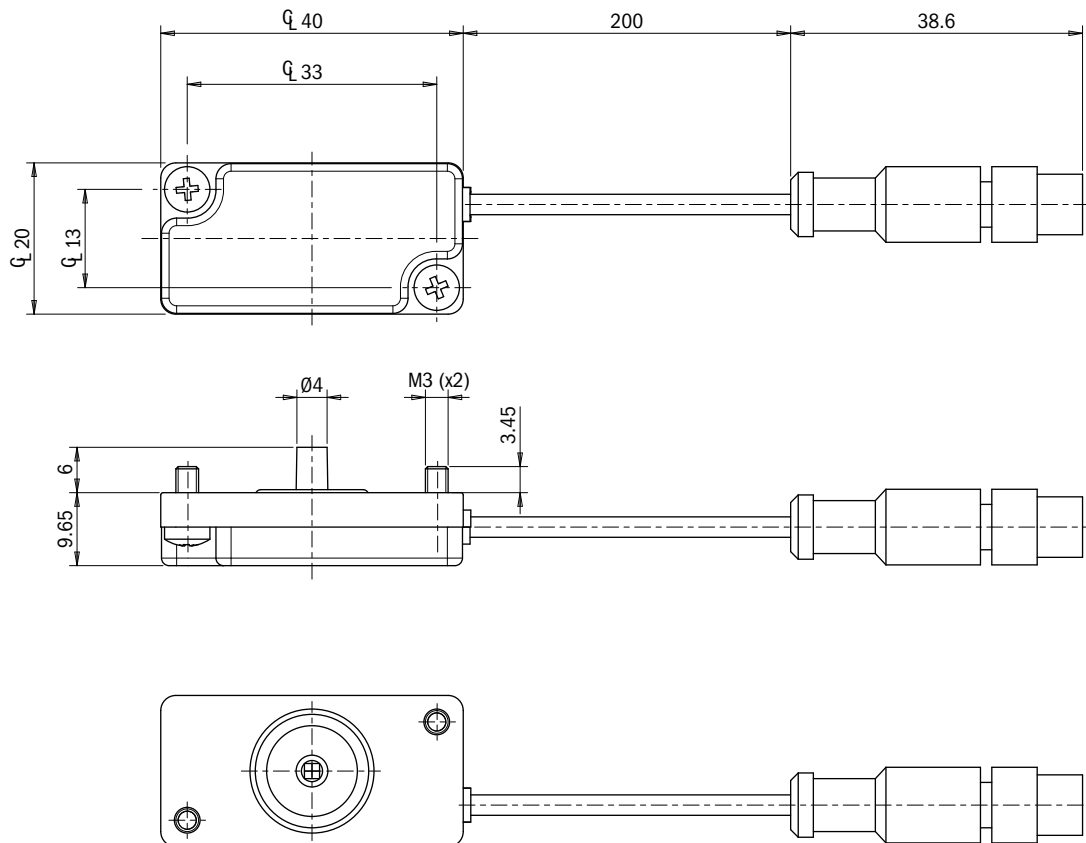

Identification codes

Alphanumeric code	Description	Order code
VACSW-30-3N203-G	Pre-set vacuum switch PNP -30 kPa with digital output, cable L= 30 cm with M8x1 3-LPn male connector	3030119
VACSW-50-3N203-G	Pre-set vacuum switch PNP -50 kPa with digital output, cable L= 30 cm with M8x1 3-LPn male connector	3030120
VACSW-70-3N203-G	Pre-set vacuum switch PNP -70 kPa with digital output, cable L= 30 cm with M8x1 3-LPn male connector	3030121
VACSW-30-3M203-G	Pre-set vacuum switch NPN -30 kPa with digital output, cable L= 30 cm with M8x1 3-LPn male connector	3030122
VACSW-50-3M203-G	Pre-set vacuum switch NPN -50 kPa with digital output, cable L= 30 cm with M8x1 3-LPn male connector	3030123
VACSW-70-3M203-G	Pre-set vacuum switch NPN -70 kPa with digital output, cable L= 30 cm with M8x1 3-LPn male connector	3030124



Click for Pricing & Add to Cart

EJ-BSV-MEDIUM

- Ideal for applications in dusty environments
- Adjustable blow-off for quick release and cleaning of the EJ cartridge
- Tank capacity 10 cm³
- Available with Gimatic's integrated vacuum switch, pre-set (-30, -50 and -70 kPa), in the PNP and NPN versions
- The 3/2 valve (NC, NO) feeds the vacuum pump and the blow-off function
- Integrated silencer
- Anodized aluminum manifold
- Available with one two-stage EJ-MEDIUM cartridge (EJ-HF, EJ-HV), high suction flow rate and low energy consumption

Typical applications

- Packaging machines, for the food and pharmaceutical sector
- Handling of cosmetic products
- Pick-up of porous items (cardboard, wooden sheets)

NEW



Application example



Technical features

Max feed pressure	0.7 MPa
Weight	250 ± 257 g
Material	PA, SS, POM, Al, Nitrile (NBR)
Noise level	< 70 dB
Solenoid valve opening response time	< 15 ms
Solenoid valve closing response time	< 10 ms
Power supply	24 V
Power absorption	1.2 W
Valve IP rating	IP56

Suction flow rate

Model	Feed pressure [MPa]	Air consumption [l/s]	Suction flow rate [l/s] at different vacuum levels [kPa]										Max vacuum [kPa]
			0	-10	-20	-30	-40	-50	-60	-70	-80	-90	
EJ-BSV-M-HF-2	0.6	0.43	0.78	0.68	0.52	0.31	0.21	0.15	0.10	0.08	—	—	-73
EJ-BSV-M-HV-2	0.5	0.47	0.76	0.63	0.54	0.32	0.17	0.15	0.11	0.07	0.05	0.01	-94

For technical specifications regarding the suction flow rate and the air consumption at different pressures, please refer to the technical data sheets of the EJ-MEDIUM cartridges in the two-stage version

Evacuation time

Model	Feed pressure [MPa]	Air consumption [l/s]	Evacuation time [s/l] to reach different vacuum levels [kPa]										Max vacuum [kPa]
			-10	-20	-30	-40	-50	-60	-70	-80	-90		
EJ-BSV-M-HF-2	0.6	0.43	0.13	0.30	0.54	0.9	1.5	2.3	3.2	—	—	-73	
EJ-BSV-M-HV-2	0.5	0.47	0.14	0.32	0.55	1.0	1.6	2.4	3.5	5.1	8.7	-94	

For technical specifications regarding the evacuation time and the consumption at different pressures, please refer to the technical data sheets of the EJ-MEDIUM cartridges, in the two-stage version

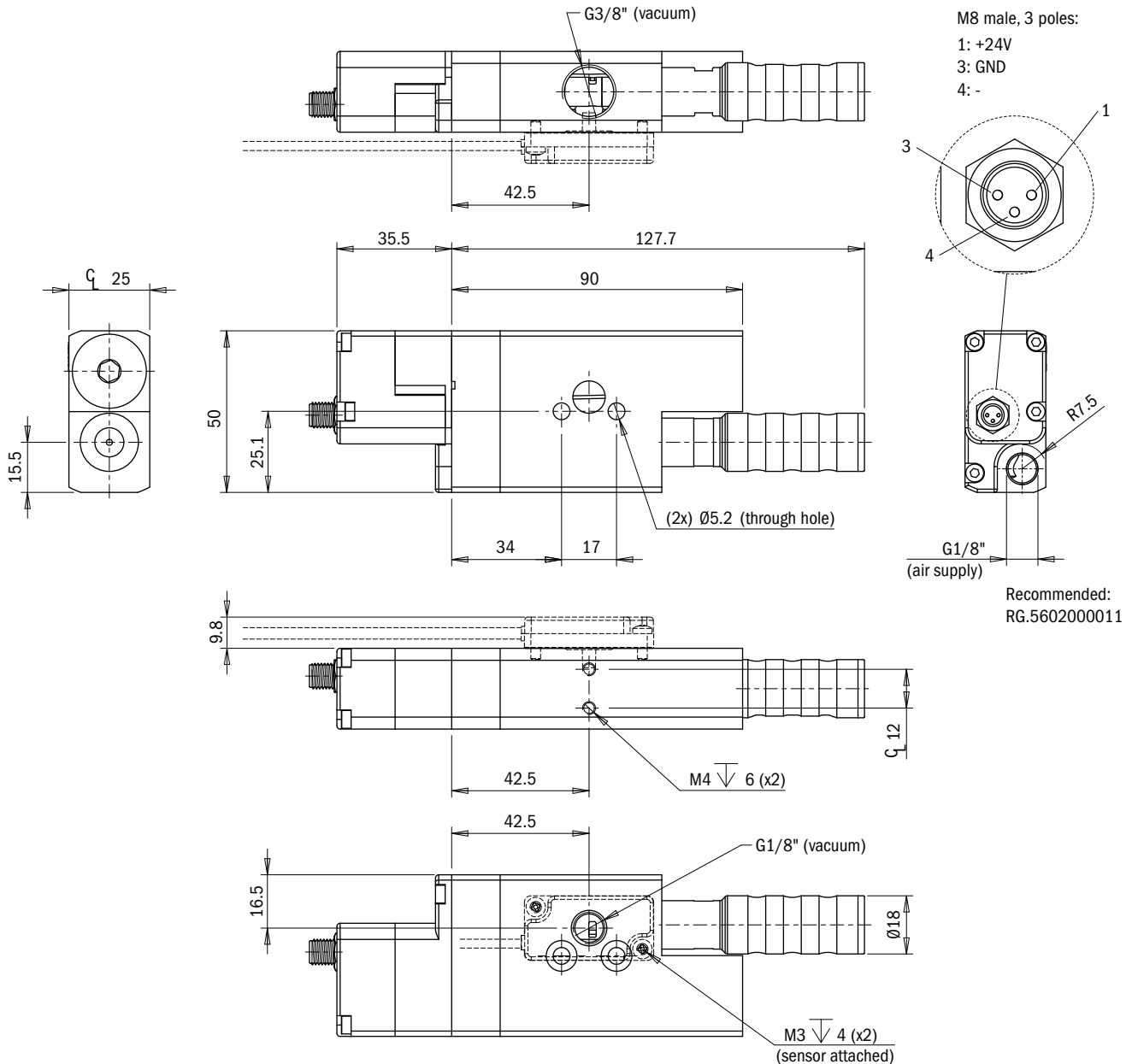

Identification codes

Alphanumeric code	Description	Order code
EJ-BSV-M-HF-2-NC	EJ-BLOWOFF-MEDIUM-HF-2 vacuum pump, electrically driven, NC, with holder and integrated silencer	3030198
EJ-BSV-M-HF-2-NC-VSW-30-P	EJ-BLOWOFF-MEDIUM-HF-2 vacuum pump, electrically driven, NC, with holder and integrated silencer, pre-set vacuum switch PNP -30 kPa	3030199
EJ-BSV-M-HF-2-NC-VSW-50-P	EJ-BLOWOFF-MEDIUM-HF-2 vacuum pump, electrically driven, NC, with holder and integrated silencer, pre-set vacuum switch PNP -50 kPa	3030200
EJ-BSV-M-HF-2-NC-VSW-70-P	EJ-BLOWOFF-MEDIUM-HF-2 vacuum pump, electrically driven, NC, with holder and integrated silencer, pre-set vacuum switch PNP -70 kPa	3030201
EJ-BSV-M-HF-2-NC-VSW-30-N	EJ-BLOWOFF-MEDIUM-HF-2 vacuum pump, electrically driven, NC, with holder and integrated silencer, pre-set vacuum switch NPN -30 kPa	3030202
EJ-BSV-M-HF-2-NC-VSW-50-N	EJ-BLOWOFF-MEDIUM-HF-2 vacuum pump, electrically driven, NC, with holder and integrated silencer, pre-set vacuum switch NPN -50 kPa	3030203
EJ-BSV-M-HF-2-NC-VSW-70-N	EJ-BLOWOFF-MEDIUM-HF-2 vacuum pump, electrically driven, NC, with holder and integrated silencer, pre-set vacuum switch NPN -70 kPa	3030204
EJ-BSV-M-HF-2-NO	EJ-BLOWOFF-MEDIUM-HF-2 vacuum pump, electrically driven, NO, with holder and integrated silencer	3030212
EJ-BSV-M-HF-2-NO-VSW-30-P	EJ-BLOWOFF-MEDIUM-HF-2 vacuum pump, electrically driven, NO, with holder and integrated silencer, pre-set vacuum switch PNP -30 kPa	3030213
EJ-BSV-M-HF-2-NO-VSW-50-P	EJ-BLOWOFF-MEDIUM-HF-2 vacuum pump, electrically driven, NO, with holder and integrated silencer, pre-set vacuum switch PNP -50 kPa	3030214
EJ-BSV-M-HF-2-NO-VSW-70-P	EJ-BLOWOFF-MEDIUM-HF-2 vacuum pump, electrically driven, NO, with holder and integrated silencer, pre-set vacuum switch PNP -70 kPa	3030215
EJ-BSV-M-HF-2-NO-VSW-30-N	EJ-BLOWOFF-MEDIUM-HF-2 vacuum pump, electrically driven, NO, with holder and integrated silencer, pre-set vacuum switch NPN -30 kPa	3030216
EJ-BSV-M-HF-2-NO-VSW-50-N	EJ-BLOWOFF-MEDIUM-HF-2 vacuum pump, electrically driven, NO, with holder and integrated silencer, pre-set vacuum switch NPN -50 kPa	3030217
EJ-BSV-M-HF-2-NO-VSW-70-N	EJ-BLOWOFF-MEDIUM-HF-2 vacuum pump, electrically driven, NO, with holder and integrated silencer, pre-set vacuum switch NPN -70 kPa	3030218



Click for Pricing & Add to Cart

Identification codes		
Alphanumeric code	Description	Order code
EJ-BSV-M-HV-2-NC	EJ-BLOWOFF-MEDIUM-HV-2 vacuum pump, electrically driven, NC, with holder and integrated silencer	3030170
EJ-BSV-M-HV-2-NC-VSW-30-P	EJ-BLOWOFF-MEDIUM-HV-2 vacuum pump, electrically driven, NC, with holder and integrated silencer, pre-set vacuum switch PNP -30 kPa	3030171
EJ-BSV-M-HV-2-NC-VSW-50-P	EJ-BLOWOFF-MEDIUM-HV-2 vacuum pump, electrically driven, NC, with holder and integrated silencer, pre-set vacuum switch PNP -50 kPa	3030172
EJ-BSV-M-HV-2-NC-VSW-70-P	EJ-BLOWOFF-MEDIUM-HV-2 vacuum pump, electrically driven, NC, with holder and integrated silencer, pre-set vacuum switch PNP -70 kPa	3030173
EJ-BSV-M-HV-2-NC-VSW-30-N	EJ-BLOWOFF-MEDIUM-HV-2 vacuum pump, electrically driven, NC, with holder and integrated silencer, pre-set vacuum switch NPN -30 kPa	3030174
EJ-BSV-M-HV-2-NC-VSW-50-N	EJ-BLOWOFF-MEDIUM-HV-2 vacuum pump, electrically driven, NC, with holder and integrated silencer, pre-set vacuum switch NPN -50 kPa	3030175
EJ-BSV-M-HV-2-NC-VSW-70-N	EJ-BLOWOFF-MEDIUM-HV-2 vacuum pump, electrically driven, NC, with holder and integrated silencer, pre-set vacuum switch NPN -70 kPa	3030176
EJ-BSV-M-HV-2-NO	EJ-BLOWOFF-MEDIUM-HV-2 vacuum pump, electrically driven, NO, with holder and integrated silencer	3030184
EJ-BSV-M-HV-2-NO-VSW-30-P	EJ-BLOWOFF-MEDIUM-HV-2 vacuum pump, electrically driven, NO, with holder and integrated silencer, pre-set vacuum switch PNP -30 kPa	3030185
EJ-BSV-M-HV-2-NO-VSW-50-P	EJ-BLOWOFF-MEDIUM-HV-2 vacuum pump, electrically driven, NO, with holder and integrated silencer, pre-set vacuum switch PNP -50 kPa	3030186
EJ-BSV-M-HV-2-NO-VSW-70-P	EJ-BLOWOFF-MEDIUM-HV-2 vacuum pump, electrically driven, NO, with holder and integrated silencer, pre-set vacuum switch PNP -70 kPa	3030187
EJ-BSV-M-HV-2-NO-VSW-30-N	EJ-BLOWOFF-MEDIUM-HV-2 vacuum pump, electrically driven, NO, with holder and integrated silencer, pre-set vacuum switch NPN -30 kPa	3030188
EJ-BSV-M-HV-2-NO-VSW-50-N	EJ-BLOWOFF-MEDIUM-HV-2 vacuum pump, electrically driven, NO, with holder and integrated silencer, pre-set vacuum switch NPN -50 kPa	3030189
EJ-BSV-M-HV-2-NO-VSW-70-N	EJ-BLOWOFF-MEDIUM-HV-2 vacuum pump, electrically driven, NO, with holder and integrated silencer, pre-set vacuum switch NPN -70 kPa	3030190

Vacuum pumps / EJ-BSVLG

EJ-BSVLG-LARGE-ISO

- Ideal for centralized and decentralized applications
- Excellent ratio between suction flow rate and compressed air consumption
- Available with ON/OFF vacuum valve, blow-off, and integrated manual override control
- POM manifold prepared for mounting ISO 15407-1 (18 mm) valve of type 2x 3/2 NC or 5/3 with closed centre
- Available with two- and three-stage EJ-LARGE cartridges (EJ-HF and EJ-HV)
- Additional vacuum ports for mounting a vacuum switch
- In-line design for greater dirt tolerance
- Installable in series

Typical applications

- Case packing and cartoning machines
- In applications that require an integrated control system with reduced weight and compact dimensions (electronics sector)
- Handling objects with heavy weights and porous surfaces

NEW

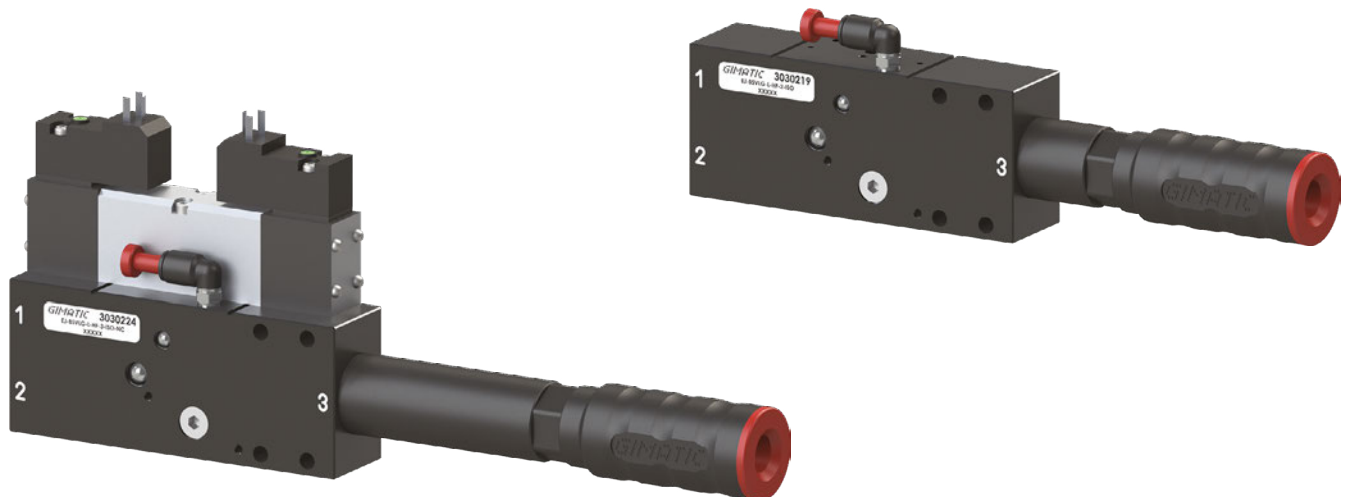

Application example

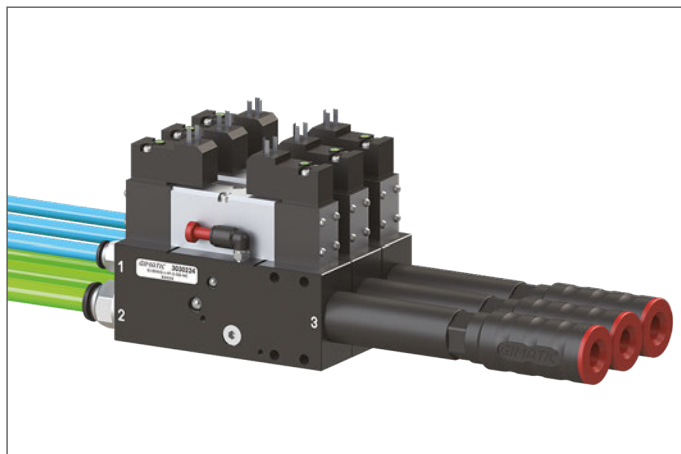

Pump technical features

Max feed pressure	0.7 MPa
Weight (with solenoid valve)	260 (450) g
Material	SS, POM, Al, Nitrile (NBR)
Noise level	< 70 dB
Operating temperature	23 – 122 °F

Solenoid valve technical features (optional)

Brand	Norgren
Model	V415A22D-C313A
Operation	2x 3/2 Normally closed (NC), spring loaded
Type of electrical connection	DIN 43 650 Model C
Drive voltage	24 Vcc ±10%
Power absorption	1.2 W
IP rating	IP65; NEMA 4
Piloting	External
Standard	ISO 15407-1: VDMA 24 563

Features of compatible valves

Standard	ISO 15407-1 (18 mm)			
Required piloting	External			
Operation	2x 3/2 NC	A	5/3 CC	B
Piloting outlet	Not conveyed			

Example of compatible valves

Brand	Coding	Lay-out
Aignep	05V S0 7 CC 00	B
Festo	VSVA-B-T32C-AZH-A2-1C1	A
Festo	VSVA-B-T32C-AZH-A2-1R5L	A
Festo	VSVA-B-P53C-ZH-A2-1C1	B
Norgren	V415A22D-C313A	A

[A]

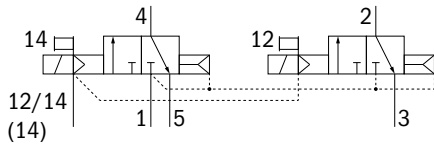

[B]

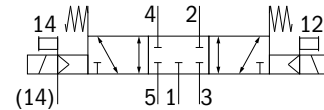

Suction flow rate

Model	Feed pressure [MPa]	Air consumption [NI/s]	Suction flow rate [NI/s] at different vacuum levels [kPa]										Max vacuum [kPa]
			0	-10	-20	-30	-40	-50	-60	-70	-80	-90	
EJ-BSVLG-L-HF-2-ISO	0.6	1.7	3.2	3.0	2.5	1.7	0.89	0.62	0.51	0.31	–	–	-73
EJ-BSVLG-L-HF-3-ISO	0.6	1.7	5.9	3.5	2.5	1.7	0.89	0.62	0.51	0.31	–	–	-73
EJ-BSVLG-L-HV-2-ISO	0.5	1.93	2.6	2.4	1.7	1.3	0.70	0.55	0.40	0.31	0.15	0.02	-94
EJ-BSVLG-L-HV-3-ISO	0.5	1.93	6.0	3.7	2.1	1.9	0.79	0.55	0.40	0.31	0.15	0.02	-94

For technical specifications, regarding the suction flow rate and the air consumption at different pressures, please refer to the technical data sheets of the EJ-LARGE cartridges in the two- and three-stage versions

Evacuation time

Model	Feed pressure [MPa]	Air consumption [NI/s]	Evacuation time [s/l] to reach different vacuum levels [kPa]										Max vacuum [kPa]
			-10	-20	-30	-40	-50	-60	-70	-80	-90		
EJ-BSVLG-L-HF-2-ISO	0.6	1.7	0.03	0.07	0.12	0.19	0.3	0.4	0.7	–	–	-73	
EJ-BSVLG-L-HF-3-ISO	0.6	1.7	0.02	0.05	0.10	0.19	0.3	0.4	0.7	–	–	-73	
EJ-BSVLG-L-HV-2-ISO	0.5	1.93	0.04	0.09	0.16	0.3	0.4	0.6	0.9	1.3	2.5	-94	
EJ-BSVLG-L-HV-3-ISO	0.5	1.93	0.02	0.06	0.10	0.2	0.3	0.4	0.7	1.1	2.4	-94	

For technical specifications regarding the evacuation time and the consumption at different pressures, please refer to the technical data sheets of the EJ-LARGE cartridges, in the two- and three-stage versions

Identification codes

Alphanumeric code	Description	Order code
EJ-BSVLG-L-HF-2-ISO	EJ-BSVLG-LARGE-HF-2-ISO vacuum pump with holder and integrated silencer, ready for ISO 15407-1 valve, G1/2" vacuum port	3030219
EJ-BSVLG-L-HF-3-ISO	EJ-BSVLG-LARGE-HF-3-ISO vacuum pump with holder and integrated silencer, ready for ISO 15407-1 valve, G1/2" vacuum port	3030220
EJ-BSVLG-L-HV-2-ISO	EJ-BSVLG-LARGE-HV-2-ISO vacuum pump with holder and integrated silencer, ready for ISO 15407-1 valve, G1/2" vacuum port	3030221
EJ-BSVLG-L-HV-3-ISO	EJ-BSVLG-LARGE-HV-3-ISO vacuum pump with holder and integrated silencer, ready for ISO 15407-1 valve, G1/2" vacuum port	3030222
EJ-BSVLG-L-HF-2-ISO-NC	EJ-BSVLG-LARGE-HF-ISO-2 vacuum pump with holder and integrated silencer, with ISO 15407-1 3/2 x2 NC solenoid valve for vacuum and blow-off, G1/2" vacuum port	3030223
EJ-BSVLG-L-HF-3-ISO-NC	EJ-BSVLG-LARGE-HF-3-ISO vacuum pump with holder and integrated silencer, with ISO 15407-1 3/2 x2 NC solenoid valve for vacuum and blow-off, G1/2" vacuum port	3030224
EJ-BSVLG-L-HV-2-ISO-NC	EJ-BSVLG-LARGE-HV-ISO-2 vacuum pump with holder and integrated silencer, with ISO 15407-1 3/2 x2 NC solenoid valve for vacuum and blow-off, G1/2" vacuum port	3030225
EJ-BSVLG-L-HV-3-ISO-NC	EJ-BSVLG-LARGE-HV-3-ISO vacuum pump with holder and integrated silencer, with ISO 15407-1 3/2 x2 NC solenoid valve for vacuum and blow-off, G1/2" vacuum port	3030226

Identification codes

Alphanumeric code	Accessories	Order code
EJ-CON-15MM-24V	Transparent 15 mm connector with LED and VDR, 0 - 24 VDC	3030162

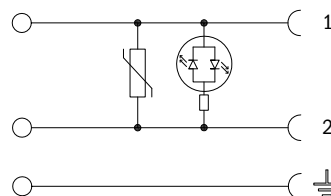
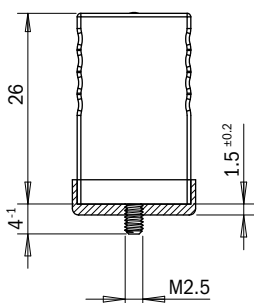
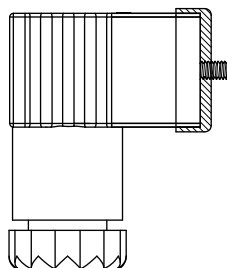
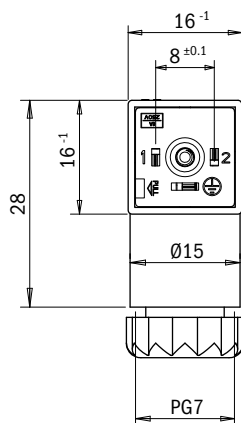

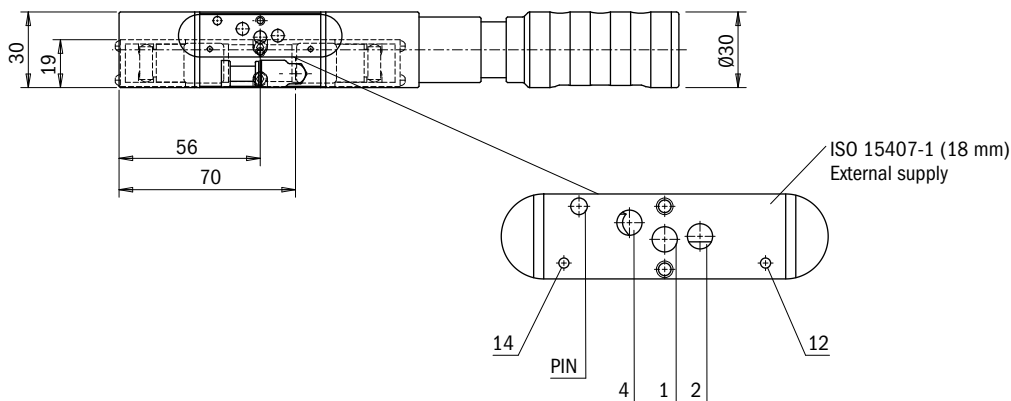
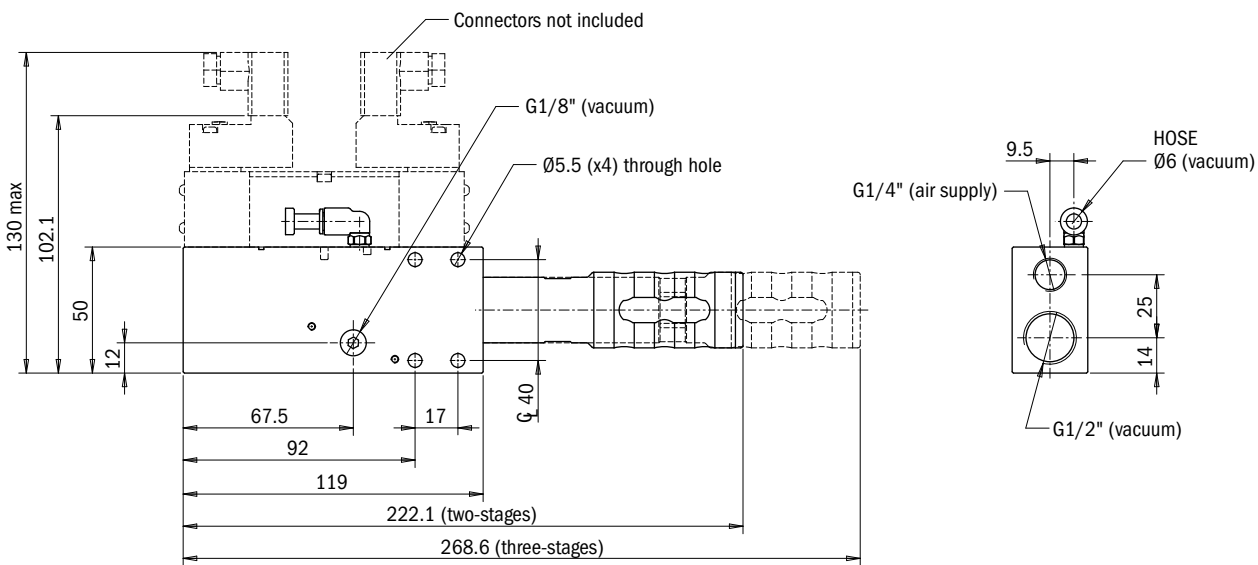
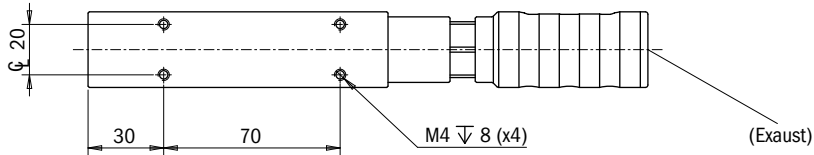

Function	n°
General supply	1
Blowoff	2
Vacuum supply	4
External supply	12 / 14

Vacuum pumps / EJ-MLG

EJ-MLG-LARGE

- Ideal for centralized applications
- Lightweight, POM body
- G3/4" vacuum port
- Integrated silencer
- Low noise and short cycle time
- Multiple vacuum connections
- Short evacuation time
- Prearranged with VACSW-3N203-G (PNP) and VACSW-3M203-G (NPN) vacuum switches
- Available with two- and three-stage EJ-LARGE cartridge (EJ-HF and EJ-HV)

Typical applications

- Graphic sector, offset machines, pre- and post-press
- Liquid filling and emptying applications
- Handling of objects with high weights or uneven surfaces



Application example

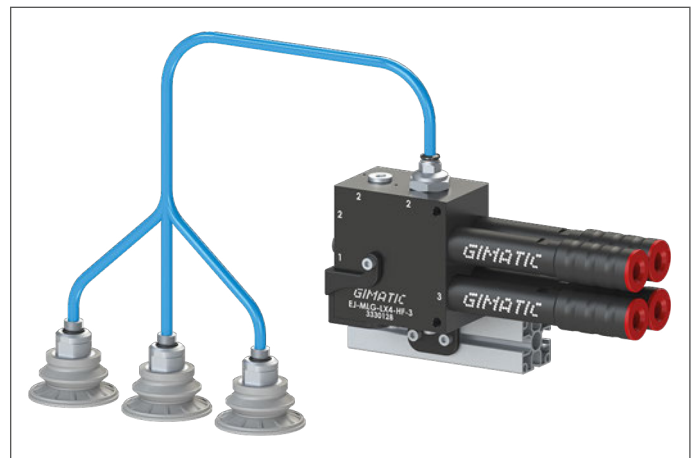

Technical features

Max feed pressure	0.7 MPa
Weight	514 ± 1017 g
Material	PA, SS, POM, Nitrile (NBR)
Noise level	70 ± 75 dB

Suction flow rate

Model	Feed pressure [MPa]	Air consumption [l/s]	Suction flow rate [l/s] at different vacuum levels [kPa]										Max vacuum [kPa]
			0	-10	-20	-30	-40	-50	-60	-70	-80	-90	
EJ-MLG-LX2-HF-3	0.6	3.4	6.2	6.0	5.0	3.4	1.78	1.24	1.02	0.62	–	–	-73
EJ-MLG-LX2-HF-2	0.6	3.4	11.8	7.0	5.0	3.4	1.78	1.24	1.02	0.62	–	–	-73
EJ-MLG-LX2-HV-2	0.5	3.86	5.2	4.8	3.4	2.6	1.4	1.1	0.8	0.62	0.3	0.04	-94
EJ-MLG-LX2-HV-3	0.5	3.86	12.0	7.4	4.2	3.8	1.58	1.1	0.8	0.62	0.3	0.04	-94
EJ-MLG-LX3-HF-2	0.6	5.1	9.6	9.0	7.5	5.1	2.67	1.86	1.53	0.93	–	–	-73
EJ-MLG-LX3-HF-3	0.6	5.1	17.7	10.5	7.5	5.1	2.67	1.86	1.53	0.93	–	–	-73
EJ-MLG-LX3-HV-2	0.5	5.79	7.8	7.2	5.1	3.9	2.1	1.65	1.2	0.93	0.45	0.06	-94
EJ-MLG-LX3-HV-3	0.5	5.79	18.0	11.1	6.3	5.7	2.37	1.65	1.2	0.93	0.45	0.06	-94
EJ-MLG-LX4-HF-2	0.6	6.8	12.8	12.0	10.0	6.8	3.56	2.48	2.04	1.24	–	–	-73
EJ-MLG-LX4-HF-3	0.6	6.8	23.6	14.0	10.0	6.8	3.56	2.48	2.04	1.24	–	–	-73
EJ-MLG-LX4-HV-2	0.5	7.72	10.4	9.6	6.8	1.3	2.8	2.2	1.6	1.24	0.6	0.08	-94
EJ-MLG-LX4-HV-3	0.5	7.72	24.0	14.8	8.4	7.6	3.16	2.2	1.6	1.24	0.6	0.08	-94

For technical specifications, regarding the suction flow rate and the air consumption at different pressures, please refer to the technical data sheets of the EJ-LARGE cartridges in the two- and three-stage versions

Evacuation time

Model	Feed pressure [MPa]	Air consumption [NI/s]	Evacuation time [s/l] to reach different vacuum levels [kPa]									Max vacuum [kPa]
			-10	-20	-30	-40	-50	-60	-70	-80	-90	
EJ-MLG-LX2-HF-2	0.6	3.4	0.015	0.035	0.06	0.095	0.15	0.2	0.35	–	–	-73
EJ-MLG-LX2-HF-3	0.6	3.4	0.01	0.025	0.05	0.095	0.15	0.2	0.35	–	–	-73
EJ-MLG-LX2-HV-2	0.5	3.86	0.02	0.045	0.08	0.15	0.20	0.3	0.45	0.65	1.25	-94
EJ-MLG-LX2-HV-3	0.5	3.86	0.01	0.03	0.05	0.10	0.15	0.2	0.35	0.55	1.2	-94
EJ-MLG-LX3-HF-2	0.6	5.1	0.01	0.023	0.04	0.063	0.10	0.13	0.23	–	–	-73
EJ-MLG-LX3-HF-3	0.6	5.1	0.006	0.016	0.033	0.063	0.10	0.13	0.23	–	–	-73
EJ-MLG-LX3-HV-2	0.5	5.79	0.013	0.03	0.053	0.10	0.13	0.2	0.3	0.43	0.83	-94
EJ-MLG-LX3-HV-3	0.5	5.79	0.006	0.02	0.033	0.066	0.10	0.13	0.23	0.36	0.8	-94
EJ-MLG-LX4-HF-2	0.6	6.8	0.007	0.017	0.03	0.047	0.075	0.10	0.175	–	–	-73
EJ-MLG-LX4-HF-3	0.6	6.8	0.005	0.012	0.025	0.047	0.075	0.10	0.175	–	–	-73
EJ-MLG-LX4-HV-2	0.5	7.72	0.019	0.022	0.04	0.075	0.10	0.15	0.225	0.32	0.62	-94
EJ-MLG-LX4-HV-3	0.5	7.72	0.005	0.015	0.025	0.05	0.075	0.10	0.175	0.27	0.6	-94

For technical specifications regarding the evacuation time and the consumption at different pressures, please refer to the technical data sheets of the EJ-LARGE cartridges, in the two- and three-stage versions

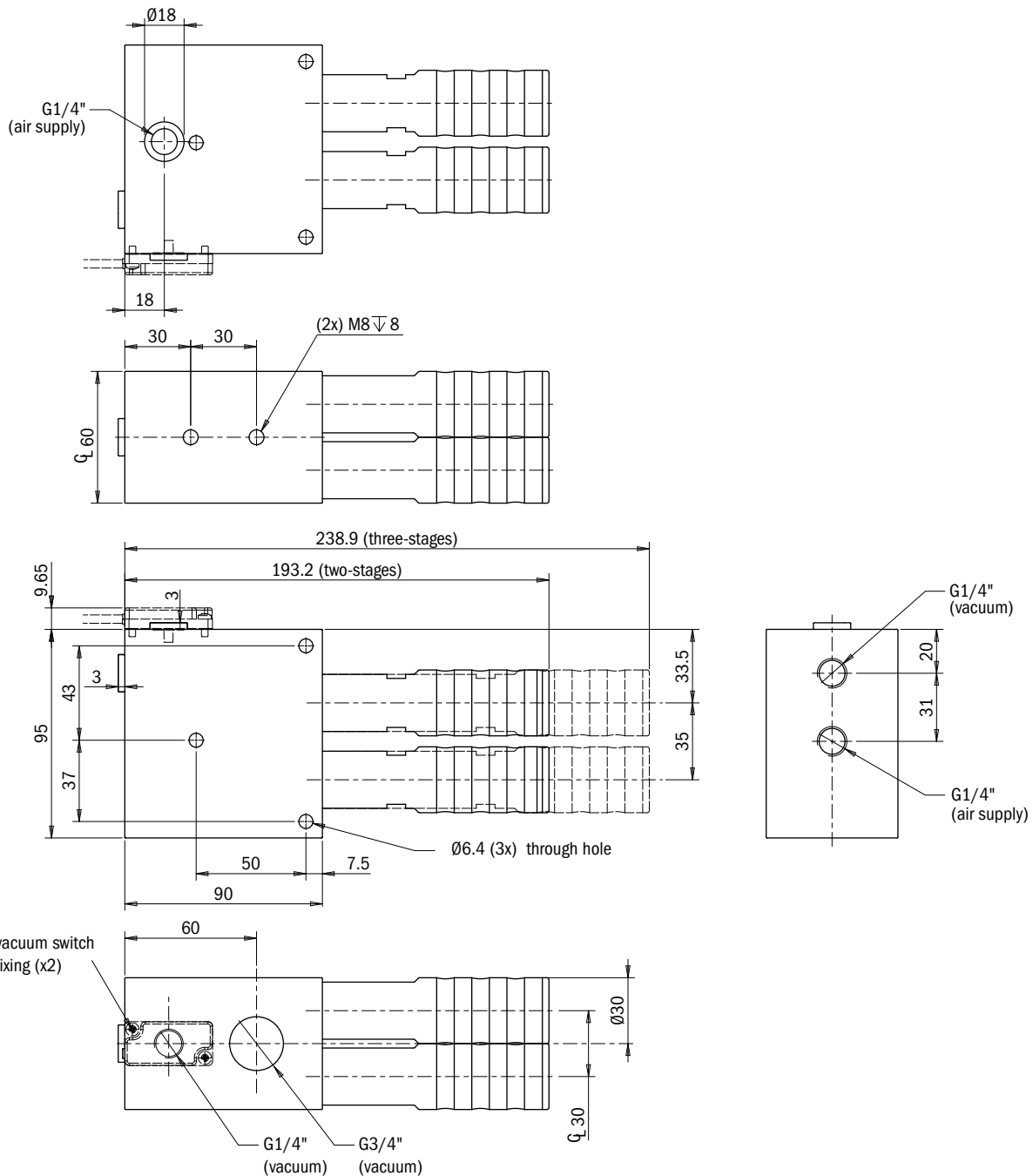

Identification codes

Alphanumeric code	Description	Order code
EJ-MLG-LX2-HF-2	EJ-MLG-LARGE2-HF-2 vacuum pump with holder and integrated silencer	3330119
EJ-MLG-LX2-HF-3	EJ-MLG-LARGE2-HF-3 vacuum pump with holder and integrated silencer	3330120
EJ-MLG-LX2-HV-2	EJ-MLG-LARGE2-HV-2 vacuum pump with holder and integrated silencer	3330121
EJ-MLG-LX2-HV-3	EJ-MLG-LARGE2-HV-3 vacuum pump with holder and integrated silencer	3330122
EJ-MLG-LX3-HF-2	EJ-MLG-LARGE3-HF-2 vacuum pump with holder and integrated silencer	3330123
EJ-MLG-LX3-HF-3	EJ-MLG-LARGE3-HF-3 vacuum pump with holder and integrated silencer	3330124
EJ-MLG-LX3-HV-2	EJ-MLG-LARGE3-HV-2 vacuum pump with holder and integrated silencer	3330125
EJ-MLG-LX3-HV-3	EJ-MLG-LARGE3-HV-3 vacuum pump with holder and integrated silencer	3330126
EJ-MLG-LX4-HF-2	EJ-MLG-LARGE4-HF-2 vacuum pump with holder and integrated silencer	3330127
EJ-MLG-LX4-HF-3	EJ-MLG-LARGE4-HF-3 vacuum pump with holder and integrated silencer	3330128
EJ-MLG-LX4-HV-2	EJ-MLG-LARGE4-HV-2 vacuum pump with holder and integrated silencer	3330129
EJ-MLG-LX4-HV-3	EJ-MLG-LARGE4-HV-3 vacuum pump with holder and integrated silencer	3330130

Vacuum pumps / EJ-CEN

EJ-CEN-LARGE

- Ideal for centralized applications
- Modular and configurable from 5 to 16 two-stage EJ-LARGE cartridges (EJ-HF and EJ-HV)
- Compact size and high suction flow rate
- Sturdy design and lightweight (aluminum body and PA12 silencer)
- Possibility of working during suction or blowing (remove silencer)

Typical applications

- Graphic design, offset machines, pre- and post-printing
- Liquid filling and emptying applications
- Handling objects with heavy weights and porous surfaces

NEW



Application example

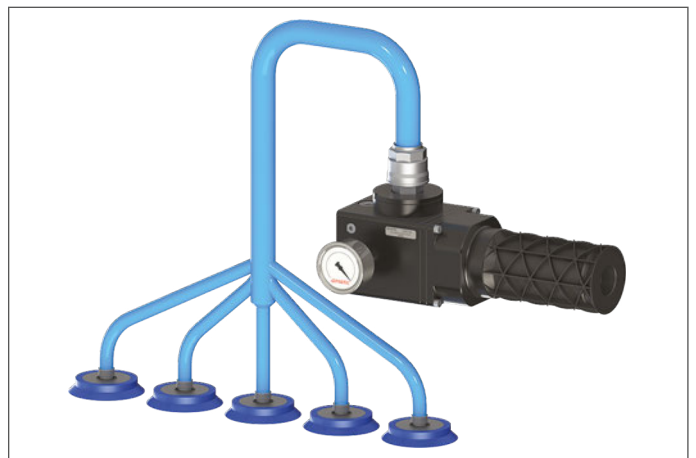

Technical features

Max feed pressure	0.7 MPa
Weight	1400 ÷ 1700 g
Material	PA12, Al, SS, Nitrile (NBR)
Noise level	< 70 dB

Suction flow rate

Model	Feed pressure [MPa]	Air consumption [NI/s]	Suction flow rate [NI/s] at different vacuum levels [kPa]										Max vacuum [kPa]
			0	-10	-20	-30	-40	-50	-60	-70	-80	-90	
EJ-CEN-LX5-HV-2-G1	0.5	9.65	13.1	12.1	8.5	6.9	3.65	2.9	2.14	1.5	0.9	0.16	-94
EJ-CEN-LX6-HV-2-G1	0.5	11.58	15.6	14.4	10.2	8.4	4.36	3.47	2.59	1.91	1.09	0.18	-94
EJ-CEN-LX7-HV-2-G1	0.5	13.51	18.2	16.8	11.9	9.9	5.10	4.05	3.01	2.25	1.24	0.21	-94
EJ-CEN-LX8-HV-2-G1	0.5	15.44	20.8	19.2	13.6	11.4	5.83	4.60	3.42	2.54	1.44	0.24	-94
EJ-CEN-LX9-HV-2-G1-1/2	0.5	17.37	23.4	21.6	14.8	12.9	6.58	5.23	3.86	2.87	1.62	0.27	-94
EJ-CEN-LX10-HV-2-G1-1/2	0.5	19.3	26.1	23.9	16.5	14.4	7.4	5.7	4.3	3.2	1.8	0.31	-94
EJ-CEN-LX11-HV-2-G1-1/2	0.5	21.23	28.6	26.4	18.2	15.9	8.4	6.37	4.72	3.53	1.98	0.32	-94
EJ-CEN-LX12-HV-2-G1-1/2	0.5	23.16	31.2	28.8	19.9	17.4	8.72	6.95	5.16	3.85	2.16	0.36	-94
EJ-CEN-LX13-HV-2-G1-1/2	0.5	25.09	33.8	31.2	21.6	18.9	9.50	7.52	5.53	4.13	2.32	0.39	-94
EJ-CEN-LX14-HV-2-G2	0.5	27.02	36.4	33.6	23.3	20.4	10.3	8.13	6.02	4.45	2.51	0.41	-94
EJ-CEN-LX15-HV-2-G2	0.5	28.95	39.1	35.9	25.1	21.9	10.9	8.7	6.43	4.81	2.71	0.45	-94
EJ-CEN-LX16-HV-2-G2	0.5	30.88	41.6	38.4	26.7	23.4	11.6	9.27	6.85	5.12	2.87	0.47	-94
EJ-CEN-LX5-HF-2-G1	0.6	8.5	16.1	12.5	10.8	8.4	4.3	2.9	2.4	1.69	-	-	-73
EJ-CEN-LX6-HF-2-G1	0.6	10.2	19.2	14.9	11.9	9.9	5.3	3.5	2.9	2.1	-	-	-73
EJ-CEN-LX7-HF-2-G1	0.6	11.9	22.4	17.5	13.4	10.9	6.2	4.3	3.5	2.4	-	-	-73
EJ-CEN-LX8-HF-2-G1	0.6	13.6	25.6	19.5	16.5	11.8	7.1	4.5	4.1	2.7	-	-	-73
EJ-CEN-LX9-HF-2-G1-1/2	0.6	15.3	28.8	22.5	18.4	14.3	7.9	5.3	4.5	3.14	-	-	-73
EJ-CEN-LX10-HF-2-G1-1/2	0.6	17.0	32.0	24.9	19.7	15.8	8.7	6.1	5.0	3.45	-	-	-73
EJ-CEN-LX11-HF-2-G1-1/2	0.6	18.7	35.2	27.5	23.7	16.7	9.6	6.2	5.4	3.83	-	-	-73
EJ-CEN-LX12-HF-2-G1-1/2	0.6	20.4	38.4	29.8	26.4	18.2	10.1	7.1	5.9	4.21	-	-	-73
EJ-CEN-LX13-HF-2-G1-1/2	0.6	22.1	41.4	32.4	28.4	21.7	11.3	7.8	6.4	4.5	-	-	-73
EJ-CEN-LX14-HF-2-G2	0.6	23.8	44.8	34.9	31.0	23.5	12.1	8.3	6.9	4.89	-	-	-73
EJ-CEN-LX15-HF-2-G2	0.6	25.5	47.9	37.5	29.3	24.5	13.6	8.8	7.4	5.25	-	-	-73
EJ-CEN-LX16-HF-2-G2	0.6	27.2	49.9	40.1	35.7	27.2	14.3	9.5	7.9	5.5	-	-	-73

For technical specifications, regarding the suction flow rate and the air consumption at different pressures, please refer to the technical data sheets of the EJ-LARGE cartridges in the two-stage version

Evacuation time

Model	Feed pressure [MPa]	Air consumption [NI/s]	Evacuation time [s/l] to reach different vacuum levels [kPa]									Max vacuum [kPa]
			-10	-20	-30	-40	-50	-60	-70	-80	-90	
EJ-CEN-LX5-HV-2-G1	0.5	9.65	0.008	0.018	0.032	0.060	0.074	0.11	0.16	0.24	0.43	-94
EJ-CEN-LX6-HV-2-G1	0.5	11.58	0.007	0.015	0.026	0.050	0.062	0.094	0.14	0.2	0.37	-94
EJ-CEN-LX7-HV-2-G1	0.5	13.51	0.006	0.012	0.022	0.042	0.052	0.080	0.13	0.18	0.30	-94
EJ-CEN-LX8-HV-2-G1	0.5	15.44	0.005	0.011	0.020	0.037	0.047	0.072	0.10	0.15	0.27	-94
EJ-CEN-LX9-HV-2-G1-1/2	0.5	17.37	0.004	0.010	0.018	0.033	0.042	0.063	0.092	0.13	0.24	-94
EJ-CEN-LX10-HV-2-G1-1/2	0.5	19.3	0.004	0.009	0.016	0.030	0.038	0.059	0.084	0.11	0.22	-94
EJ-CEN-LX11-HV-2-G1-1/2	0.5	21.23	0.004	0.008	0.015	0.036	0.034	0.052	0.076	0.11	0.2	-94
EJ-CEN-LX12-HV-2-G1-1/2	0.5	23.16	0.003	0.007	0.013	0.024	0.031	0.047	0.08	0.1	0.18	-94
EJ-CEN-LX13-HV-2-G1-1/2	0.5	25.09	0.003	0.007	0.012	0.023	0.030	0.045	0.065	0.091	0.17	-94
EJ-CEN-LX14-HV-2-G2	0.5	27.02	0.002	0.006	0.011	0.021	0.028	0.042	0.07	0.085	0.15	-94
EJ-CEN-LX15-HV-2-G2	0.5	28.95	0.002	0.006	0.010	0.020	0.025	0.038	0.056	0.08	0.14	-94
EJ-CEN-LX16-HV-2-G2	0.5	30.88	0.002	0.005	0.010	0.018	0.024	0.037	0.055	0.07	0.13	-94
EJ-CEN-LX5-HF-2-G1	0.6	8.5	0.009	0.019	0.034	0.061	0.066	0.11	0.16	-	-	-73
EJ-CEN-LX6-HF-2-G1	0.6	10.2	0.008	0.016	0.027	0.051	0.056	0.089	0.12	-	-	-73
EJ-CEN-LX7-HF-2-G1	0.6	11.9	0.007	0.013	0.024	0.043	0.049	0.075	0.11	-	-	-73
EJ-CEN-LX8-HF-2-G1	0.6	13.6	0.006	0.012	0.021	0.039	0.040	0.067	0.1	-	-	-73
EJ-CEN-LX9-HF-2-G1-1/2	0.6	15.3	0.005	0.012	0.020	0.035	0.037	0.058	0.087	-	-	-73
EJ-CEN-LX10-HF-2-G1-1/2	0.6	17.0	0.005	0.010	0.017	0.031	0.034	0.054	0.08	-	-	-73
EJ-CEN-LX11-HF-2-G1-1/2	0.6	18.7	0.005	0.009	0.016	0.036	0.03	0.048	0.072	-	-	-73
EJ-CEN-LX12-HF-2-G1-1/2	0.6	20.4	0.004	0.008	0.014	0.025	0.028	0.044	0.067	-	-	-73
EJ-CEN-LX13-HF-2-G1-1/2	0.6	22.1	0.004	0.009	0.012	0.023	0.026	0.040	0.063	-	-	-73
EJ-CEN-LX14-HF-2-G2	0.6	23.8	0.003	0.007	0.011	0.021	0.025	0.037	0.057	-	-	-73
EJ-CEN-LX15-HF-2-G2	0.6	25.5	0.003	0.007	0.010	0.020	0.023	0.035	0.052	-	-	-73
EJ-CEN-LX16-HF-2-G2	0.6	27.2	0.003	0.007	0.010	0.019	0.021	0.033	0.04	-	-	-73

For technical specifications regarding the evacuation time and the consumption at different pressures, please refer to the technical data sheets of the EJ-LARGE cartridges, in the two-stage version

Identification codes for suction applications (integrated silencer)

Alphanumeric code	Description	Order code
EJ-CEN-LX5-HV-2-G1	EJ-CEN-LARGEX5-HV vacuum pump with silencer and analogue vacuum gauge, G1" vacuum port	3330135
EJ-CEN-LX6-HV-2-G1	EJ-CEN-LARGEX6-HV vacuum pump with silencer and analogue vacuum gauge, G1" vacuum port	3330136
EJ-CEN-LX7-HV-2-G1	EJ-CEN-LARGEX7-HV vacuum pump with silencer and analogue vacuum gauge, G1" vacuum port	3330137
EJ-CEN-LX8-HV-2-G1	EJ-CEN-LARGEX8-HV vacuum pump with silencer and analogue vacuum gauge, G1" vacuum port	3330138
EJ-CEN-LX9-HV-2-G1-1/2	EJ-CEN-LARGEX9-HV vacuum pump with silencer and analogue vacuum gauge, G1-1/2" vacuum port	3330139
EJ-CEN-LX10-HV-2-G1-1/2	EJ-CEN-LARGEX10-HV vacuum pump with silencer and analogue vacuum gauge, G1-1/2" vacuum port	3330140
EJ-CEN-LX11-HV-2-G1-1/2	EJ-CEN-LARGEX11-HV vacuum pump with silencer and analogue vacuum gauge, G1-1/2" vacuum port	3330141
EJ-CEN-LX12-HV-2-G1-1/2	EJ-CEN-LARGEX12-HV vacuum pump with silencer and analogue vacuum gauge, G1-1/2" vacuum port	3330142
EJ-CEN-LX13-HV-2-G1-1/2	EJ-CEN-LARGEX13-HV vacuum pump with silencer and analogue vacuum gauge, G1-1/2" vacuum port	3330143
EJ-CEN-LX14-HV-2-G2	EJ-CEN-LARGEX14-HV vacuum pump with silencer and analogue vacuum gauge, G2" vacuum port	3330144
EJ-CEN-LX15-HV-2-G2	EJ-CEN-LARGEX15-HV vacuum pump with silencer and analogue vacuum gauge, G2" vacuum port	3330145
EJ-CEN-LX16-HV-2-G2	EJ-CEN-LARGEX16-HV vacuum pump with silencer and analogue vacuum gauge, G2" vacuum port	3330146
EJ-CEN-LX5-HF-2-G1	EJ-CEN-LARGEX5-HF vacuum pump with silencer and analogue vacuum gauge, G1" vacuum port	3330147
EJ-CEN-LX6-HF-2-G1	EJ-CEN-LARGEX6-HF vacuum pump with silencer and analogue vacuum gauge, G1" vacuum port	3330148
EJ-CEN-LX7-HF-2-G1	EJ-CEN-LARGEX7-HF vacuum pump with silencer and analogue vacuum gauge, G1" vacuum port	3330149
EJ-CEN-LX8-HF-2-G1	EJ-CEN-LARGEX8-HF vacuum pump with silencer and analogue vacuum gauge, G1" vacuum port	3330150
EJ-CEN-LX9-HF-2-G1-1/2	EJ-CEN-LARGEX9-HF vacuum pump with silencer and analogue vacuum gauge, G1-1/2" vacuum port	3330151
EJ-CEN-LX10-HF-2-G1-1/2	EJ-CEN-LARGEX10-HF vacuum pump with silencer and analogue vacuum gauge, G1-1/2" vacuum port	3330152
EJ-CEN-LX11-HF-2-G1-1/2	EJ-CEN-LARGEX11-HF vacuum pump with silencer and analogue vacuum gauge, G1-1/2" vacuum port	3330153
EJ-CEN-LX12-HF-2-G1-1/2	EJ-CEN-LARGEX12-HF vacuum pump with silencer and analogue vacuum gauge, G1-1/2" vacuum port	3330154
EJ-CEN-LX13-HF-2-G1-1/2	EJ-CEN-LARGEX13-HF vacuum pump with silencer and analogue vacuum gauge, G1-1/2" vacuum port	3330155
EJ-CEN-LX14-HF-2-G2	EJ-CEN-LARGEX14-HF vacuum pump with silencer and analogue vacuum gauge, G2" vacuum port	3330156
EJ-CEN-LX15-HF-2-G2	EJ-CEN-LARGEX15-HF vacuum pump with silencer and analogue vacuum gauge, G2" vacuum port	3330157
EJ-CEN-LX16-HF-2-G2	EJ-CEN-LARGEX16-HF vacuum pump with silencer and analogue vacuum gauge, G2" vacuum port	3330158

Identification codes for blowing applications (without integrated silencer)

Alphanumeric code	Description	Order code
EJ-CEN-LX5-HV-2-G1-H-G2	EJ-CEN-LARGEX5-HV vacuum pump, G1" vacuum port, G2" exhaust	3331135
EJ-CEN-LX6-HV-2-G1-H-G2	EJ-CEN-LARGEX6-HV vacuum pump, G1" vacuum port, G2" exhaust	3331136
EJ-CEN-LX7-HV-2-G1-H-G2	EJ-CEN-LARGEX7-HV vacuum pump, G1" vacuum port, G2" exhaust	3331137
EJ-CEN-LX8-HV-2-G1-H-G2	EJ-CEN-LARGEX8-HV vacuum pump, G1" vacuum port, G2" exhaust	3331138
EJ-CEN-LX9-HV-2-G1-1/2-H-G2	EJ-CEN-LARGEX9-HV vacuum pump, G1-1/2" vacuum port, G2" exhaust	3331139
EJ-CEN-LX10-HV-2-G1-1/2-H-G2	EJ-CEN-LARGEX10-HV vacuum pump, G1-1/2" vacuum port, G2" exhaust	3331140
EJ-CEN-LX11-HV-2-G1-1/2-H-G2	EJ-CEN-LARGEX11-HV vacuum pump, G1-1/2" vacuum port, G2" exhaust	3331141
EJ-CEN-LX12-HV-2-G1-1/2-H-G2	EJ-CEN-LARGEX12-HV vacuum pump, G1-1/2" vacuum port, G2" exhaust	3331142
EJ-CEN-LX13-HV-2-G1-1/2-H-G2	EJ-CEN-LARGEX13-HV vacuum pump, G1-1/2" vacuum port, G2" exhaust	3331143
EJ-CEN-LX14-HV-2-G2-H-G2	EJ-CEN-LARGEX14-HV vacuum pump, G2" vacuum port, G2" exhaust	3331144
EJ-CEN-LX15-HV-2-G2-H-G2	EJ-CEN-LARGEX15-HV vacuum pump, G2" vacuum port, G2" exhaust	3331145
EJ-CEN-LX16-HV-2-G2-H-G2	EJ-CEN-LARGEX16-HV vacuum pump, G2" vacuum port, G2" exhaust	3331146
EJ-CEN-LX5-HF-2-G1-H-G2	EJ-CEN-LARGEX5-HF vacuum pump, G1" vacuum port, G2" exhaust	3331147
EJ-CEN-LX6-HF-2-G1-H-G2	EJ-CEN-LARGEX6-HF vacuum pump, G1" vacuum port, G2" exhaust	3331148
EJ-CEN-LX7-HF-2-G1-H-G2	EJ-CEN-LARGEX7-HF vacuum pump, G1" vacuum port, G2" exhaust	3331149
EJ-CEN-LX8-HF-2-G1-H-G2	EJ-CEN-LARGEX8-HF vacuum pump, G1" vacuum port, G2" exhaust	3331150
EJ-CEN-LX9-HF-2-G1-1/2-H-G2	EJ-CEN-LARGEX9-HF vacuum pump, G1-1/2" vacuum port, G2" exhaust	3331151
EJ-CEN-LX10-HF-2-G1-1/2-H-G2	EJ-CEN-LARGEX10-HF vacuum pump, G1-1/2" vacuum port, G2" exhaust	3331152
EJ-CEN-LX11-HF-2-G1-1/2-H-G2	EJ-CEN-LARGEX11-HF vacuum pump, G1-1/2" vacuum port, G2" exhaust	3331153
EJ-CEN-LX12-HF-2-G1-1/2-H-G2	EJ-CEN-LARGEX12-HF vacuum pump, G1-1/2" vacuum port, G2" exhaust	3331154
EJ-CEN-LX13-HF-2-G1-1/2-H-G2	EJ-CEN-LARGEX13-HF vacuum pump, G1-1/2" vacuum port, G2" exhaust	3331155
EJ-CEN-LX14-HF-2-G2-H-G2	EJ-CEN-LARGEX14-HF vacuum pump, G2" vacuum port, G2" exhaust	3331156
EJ-CEN-LX15-HF-2-G2-H-G2	EJ-CEN-LARGEX15-HF vacuum pump, G2" vacuum port, G2" exhaust	3331157
EJ-CEN-LX16-HF-2-G2-H-G2	EJ-CEN-LARGEX16-HF vacuum pump, G2" vacuum port, G2" exhaust	3331158

Identification codes

Alphanumeric code	Accessories	Order code
EJ-RDC-G2-G1	G2" - G1" adapter	3330159
EJ-RDC-G2-G1-1/2	G2" - G1-1/2" adapter	3330160

Vacuum pumps / EJ-XPRO

EJ-XPRO

- Vacuum pump with advanced control functions, available with two-stage EJ-LARGE cartridges with non-return valve (EJ-HF, EJ-HV, EJ-LP)
- Energy saving system (ES), with manual and automatic modes, that saves up to 95% of compressed air in sealed applications
- Blow-off mechanism electrically controllable by pin or automatically at each cycle
- Large TFT colour display with intuitive and easy-to-read menu and pump status indications
- Electrical connection via M12 8-pin connector
- It can be installed in series (max 4 units)

Typical applications

- Unstacking and transfer from presses
- Removal of plastic parts
- Ergonomic manipulators where safety and ease of use are key features
- In applications that require an integrated control system with reduced weight and compact dimensions (electronics sector)
- Handling of objects with high weight and sealed surface (glass/ sheet metal)

NEW



Application example

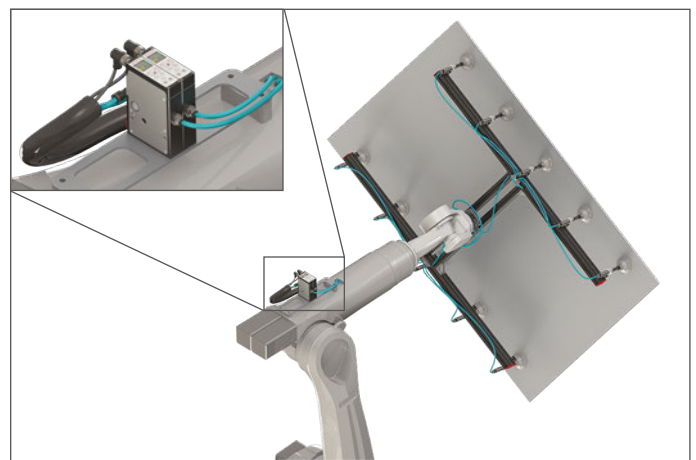

Pneumatic specifications

Max feed pressure	0.8 MPa
Minimum supply pressure	0.4 MPa
Maximum air consumption for vacuum generation	156 NI/min
Maximum air consumption for blow-off	220 NI/min
Maximum blow-off flow rate	50 NI/min
Maximum suction flow rate	190 NI/min
Maximum blow-off pressure (zero flow rate)	0.25 bar
Valve opening time	≤ 12 ms
Valve closing time	≤ 5 ms
Supply	Dry air
Pneumatic supply connection	G1/4" female
Vacuum channel connection	G1/2" female
Maximum vacuum level	-95 kPa

Technical Features

Operating temperature range	+32 - +140 °F
Mass	800 g
IP rating	IP54
Materials	Alloy 6082-T6, PA66+FG 30%, AISI 303, TPU, PC
Operating voltage	24 Vdc (±10%)
Electrical connection	M12 8-pin male
Manual controls	Yes, monostable buttons
Vacuum transducer response time	1 ms
Vacuum level analogue output	0-5 Vdc
Valve controls	Digital PNP/NPN

Suction flow rate

Model	Feed pressure [MPa]	Air consumption [NI/s]	Suction flow rate [NI/s] at different vacuum levels [kPa]										Max vacuum [kPa]
			0	-10	-20	-30	-40	-50	-60	-70	-80	-90	
EJ-XPRO-L-HF-2-NO/NC	0.6	1.7	3.2	3.0	2.5	1.7	0.89	0.62	0.51	0.31	—	—	-73
EJ-XPRO-L-HV-2-NO/NC	0.5	1.93	2.6	2.4	1.7	1.3	0.70	0.55	0.40	0.31	0.15	0.02	-94
EJ-XPRO-L-LP-2-NO/NC	0.4	2.6	2.8	2.5	2.1	1.5	1.1	0.66	0.36	0.26	0.08	—	-89

For technical specifications, regarding the suction flow rate and the air consumption at different pressures, please refer to the technical data sheets of the EJ-LARGE cartridges in the two-stage version

Evacuation time

Model	Feed pressure [MPa]	Air consumption [NI/s]	Evacuation time [s/l] to reach different vacuum levels [kPa]										Max vacuum [kPa]
			-10	-20	-30	-40	-50	-60	-70	-80	-90		
EJ-XPRO-L-HF-2-NO/NC	0.6	1.7	0.03	0.07	0.12	0.19	0.3	0.4	0.7	—	—	-73	
EJ-XPRO-L-HV-2-NO/NC	0.5	1.93	0.04	0.09	0.16	0.3	0.4	0.6	0.9	1.3	2.5	-94	
EJ-XPRO-L-LP-2-NO/NC	0.4	2.6	0.04	0.07	0.14	0.19	0.3	0.5	0.8	1.4	—	-94	

For technical specifications regarding the evacuation time and the consumption at different pressures, please refer to the technical data sheets of the EJ-LARGE cartridges, in the two-stage version

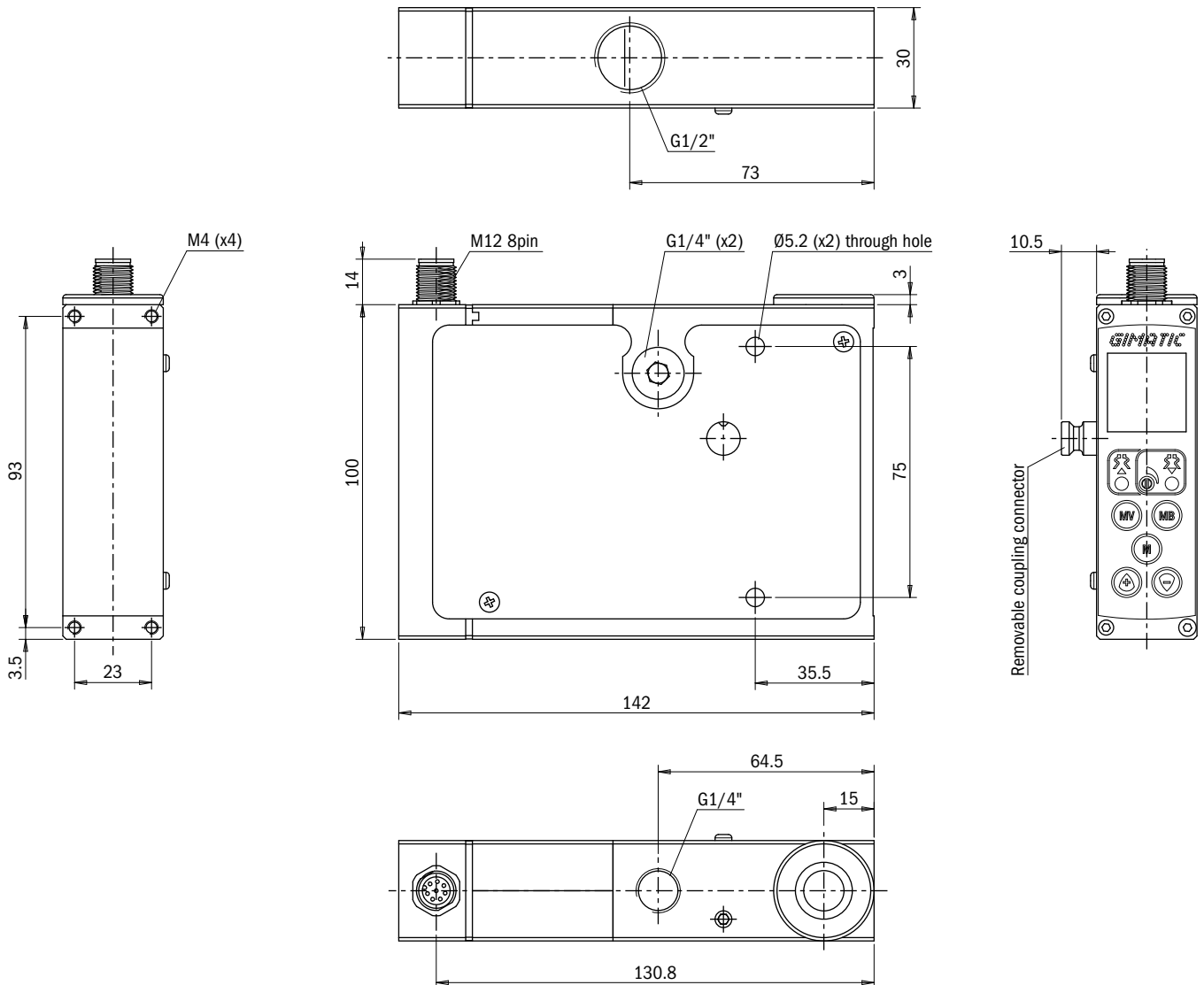

Identification codes

Alphanumeric code	Description	Order code
EJ-XPRO-L-HF-2-NO	Electronically controlled vacuum pump with integrated display, solenoid valves, keypad and 8-pin M12 connector. Large 2-stage HF cartridge with non-return valve and NO vacuum channel. Configurable as PNP or NPN, 24Vdc logic	3400100
EJ-XPRO-L-HV-2-NO	Electronically controlled vacuum pump with integrated display, solenoid valves, keypad and 8-pin M12 connector. Large 2-stage HV cartridge with non-return valve and NO vacuum channel. Configurable as PNP or NPN, 24Vdc logic	3400101
EJ-XPRO-L-LP-2-NO	Electronically controlled vacuum pump with integrated display, solenoid valves, keypad and 8-pin M12 connector. Large 2-stage LP cartridge with non-return valve and NO vacuum channel. Configurable as PNP or NPN, 24Vdc logic	3400102
EJ-XPRO-L-HF-2-NC	Electronically controlled vacuum pump with integrated display, solenoid valves, keypad and 8-pin M12 connector. Large 2-stage HF cartridge with non-return valve and NC vacuum channel. Configurable as PNP or NPN, 24Vdc logic	3400103
EJ-XPRO-L-HV-2-NC	Electronically controlled vacuum pump with integrated display, solenoid valves, keypad and 8-pin M12 connector. Large 2-stage HV cartridge with non-return valve and NC vacuum channel. Configurable as PNP or NPN, 24Vdc logic	3400104
EJ-XPRO-L-LP-2-NC	Electronically controlled vacuum pump with integrated display, solenoid valves, keypad and 8-pin M12 connector. Large 2-stage LP cartridge with non-return valve and NC vacuum channel. Configurable as PNP or NPN, 24Vdc logic	3400105



[Click for Pricing & Add to Cart](#)

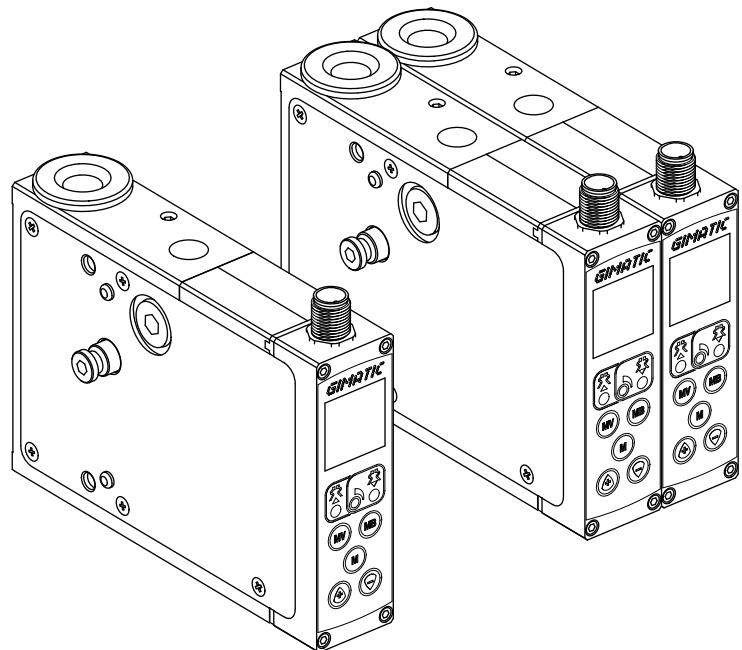

Vacuum pumps / EJ-BBT

EJ-BBT

- Ideal for applications that require high suction flow rate with low vacuum levels
- Anodized aluminum manifold
- Available in 4 diameters (10, 20, 30 and 40 mm)
- No obstruction of internal passages
- Diameter 10 mm with G3/8" threaded vacuum port to enable direct connection with a suction cup or other gripping devices

Typical applications

- Exhaust of welding fumes
- Cooling of hot parts or drying of wet parts
- Transport of waste and residual dust
- Various applications in the food industry, which require the exhaust to be drawn away

Application example



Technical features

Max feed pressure	0.4 MPa
Weight	66 ÷ 557 g
Material	Al, Nitrile (NBR)

Suction flow rate

Model	Supply pressure [MPa]	Air consumption [NI/s]	Suction flow rate [NI/s]
EJ-BBT10	0.2 ÷ 0.4	0.8 ÷ 1.7	6.7 ÷ 10.5
EJ-BBT20	0.2 ÷ 0.4	2.2 ÷ 3.2	15.5 ÷ 21.1
EJ-BBT30	0.2 ÷ 0.4	5 ÷ 8.3	18.6 ÷ 32.2
EJ-BBT40	0.2 ÷ 0.4	5.2 ÷ 8.9	21 ÷ 40

Identification codes

Alphanumeric code	Description	Order code
EJ-BBT10	Booster BBT10 in aluminum	3330131
EJ-BBT20	Booster BBT20 in aluminum	3330132
EJ-BBT30	Booster BBT30 in aluminum	3330133
EJ-BBT40	Booster BBT40 in aluminum	3330134

EJ-BBT10

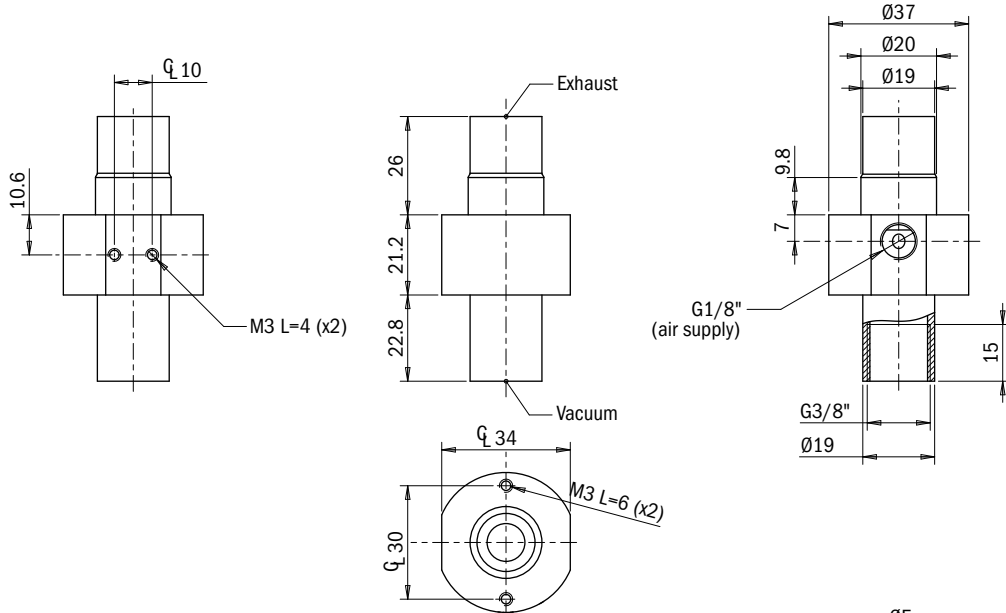

EJ-BBT20
EJ-BBT30
EJ-BBT40

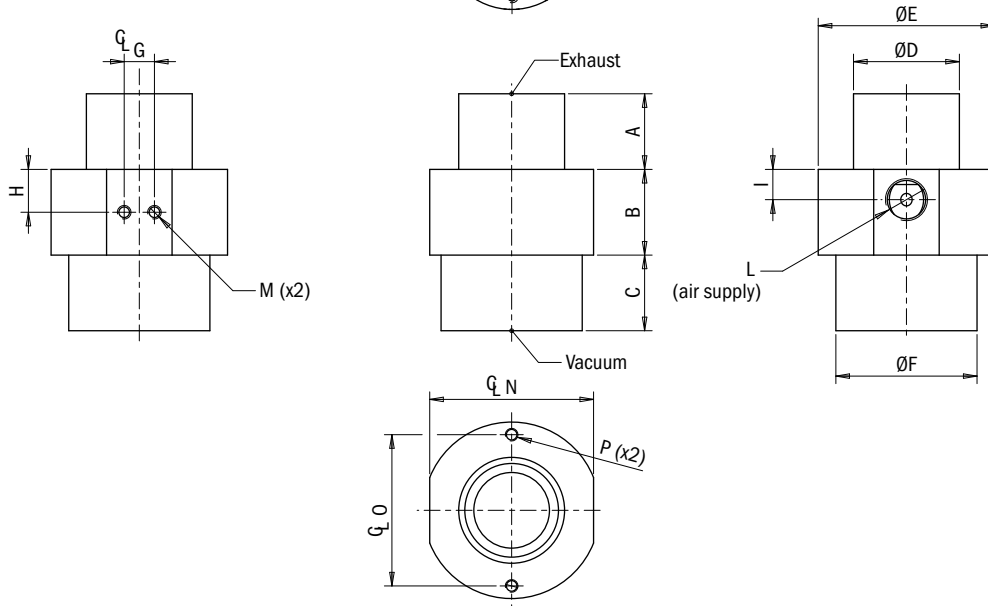

Technical data

		EJ-BBT20	EJ-BBT30	EJ-BBT40
A	[mm]	30	30	30
B	[mm]	34	34	34
C	[mm]	30	30	30
D	[mm]	32	42	52
E	[mm]	50	70	90
F	[mm]	38	56	74
G	[mm]	10	12	18
H	[mm]	17	17	17
I	[mm]	12	12	12
L		G1/4"	G3/8"	G3/8"
M		M4 L=4 mm	M5 L=6 mm	M6 L=8 mm
N	[mm]	47	65	85
O	[mm]	42	60	76
P		M4 L=8 mm	M5 L=10 mm	M6 L=12 mm

Introduction

Vacuum theory

Suction cups

Vacuum pumps

Customised solutions

Suspensions

System accessories

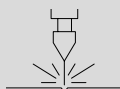
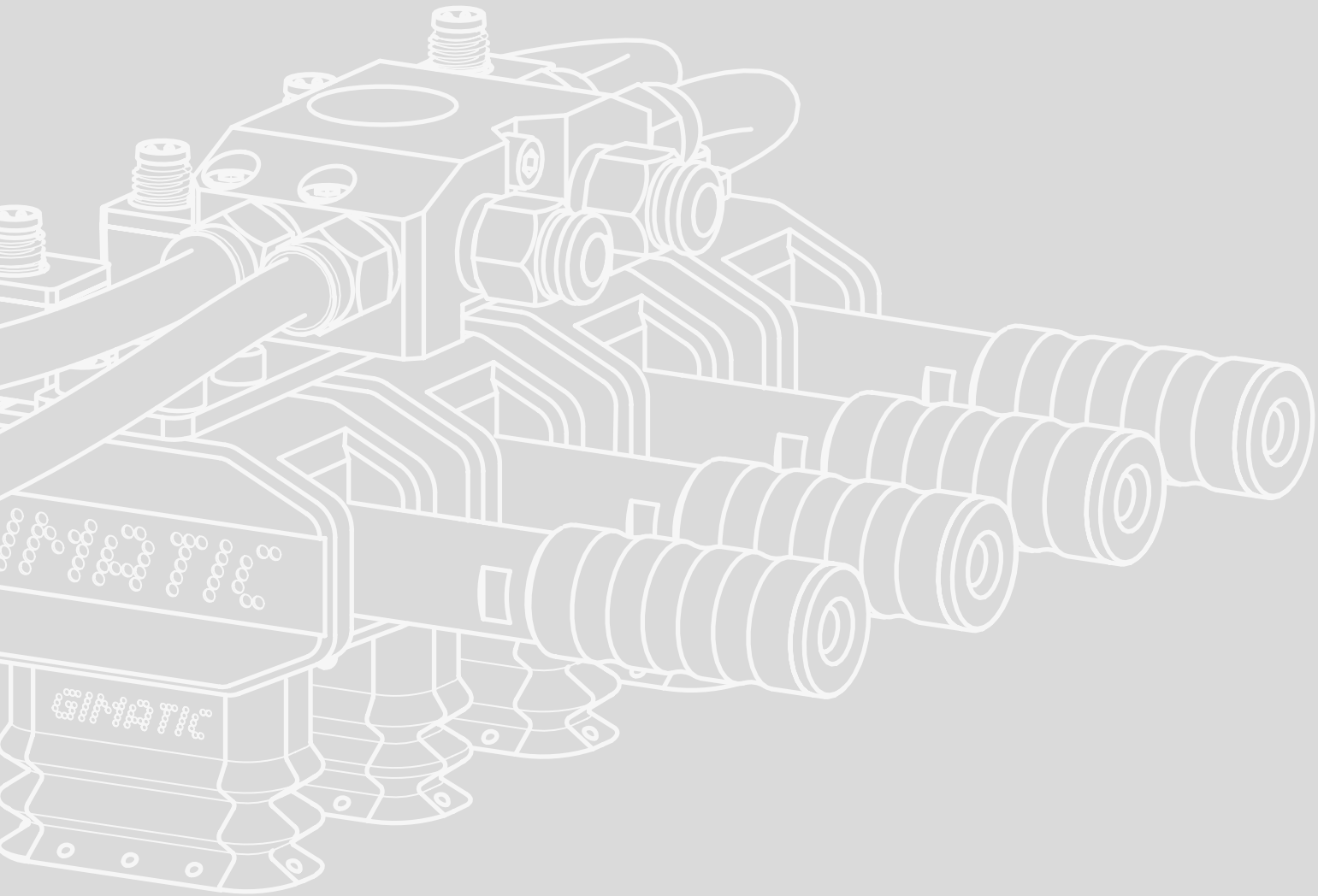

CUSTOMIZED SOLUTIONS

3D PRINTING

Following the demands of the market, Gimatic has equipped an area for 3D printing service with an HP Multi Jet Fusion system. Through a rapid prototyping service based on the customer's design, we are able to create completely customised gripping solutions that can meet the specific needs of the final customer. This technology makes products with PA12GB (Glass Beads) material, for greater rigidity, allowing our customers to receive products with low weight, high wear resistance and high quality. 3D-printed components can be flocked or fitted with rubber pads (HNBR) to provide a soft touch on the products to be handled. Threaded metal inserts are also available for mounting. 3L laser cutting and 3M metal working services are available.



Material technical specifications		Method
Material	PA12 Glass Beads	-
Density of the material	1.3 g/cm ³	ASTM D792
Tensile strength, max load	30 MPa	ASTM D638
Heat deflection temperature (@ 1.82 MPa)	114°C	ASTM D648 Test Method A

3M METAL WORKING

5-axis CNC machining service according to customer's drawing, also for individual parts.
 Lead time: 5 working days.
 Materials:

- Acetal resin (POM)
- Aluminium alloy (6000 series)

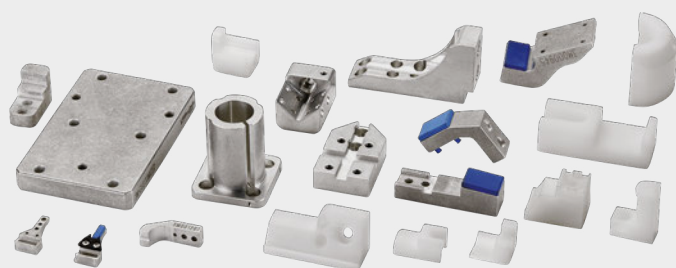

Decentralized EOAT with rapid prototyping

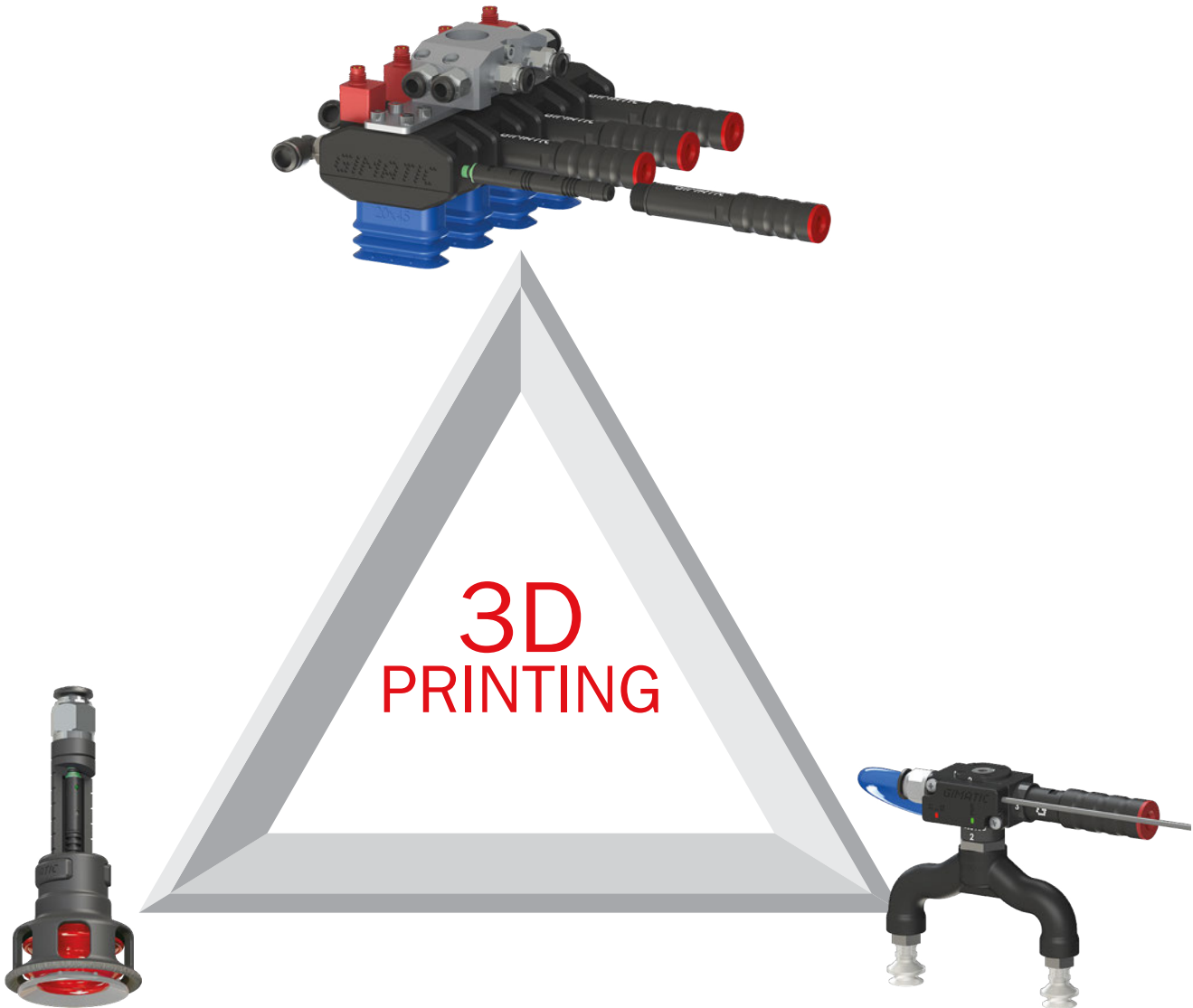

Inline pump with flocked stabilising cap

Custom solutions for Pick-and-Place applications

3L LASER CUTTING

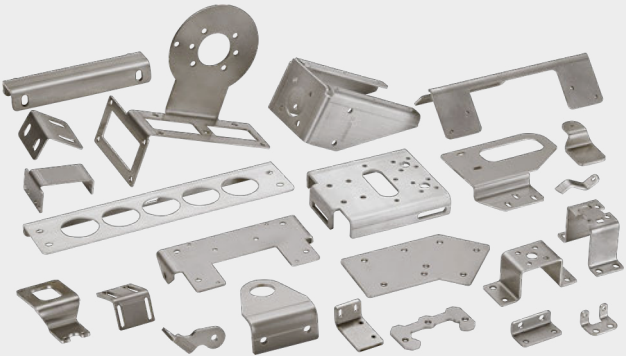

Laser cutting and bending service according to customer's drawing also for individual parts (without minimum quantities).

Lead time: 3 working days.

Materials:

- AISI 304 stainless steel (thickness: 1, 2 and 3 mm);
- Aluminium alloy 5754 (thickness 2, 3, 4 and 5 mm).

Introduction

Vacuum theory

Suction cups

Vacuum pumps

Customised solutions

Suspensions

System accessories

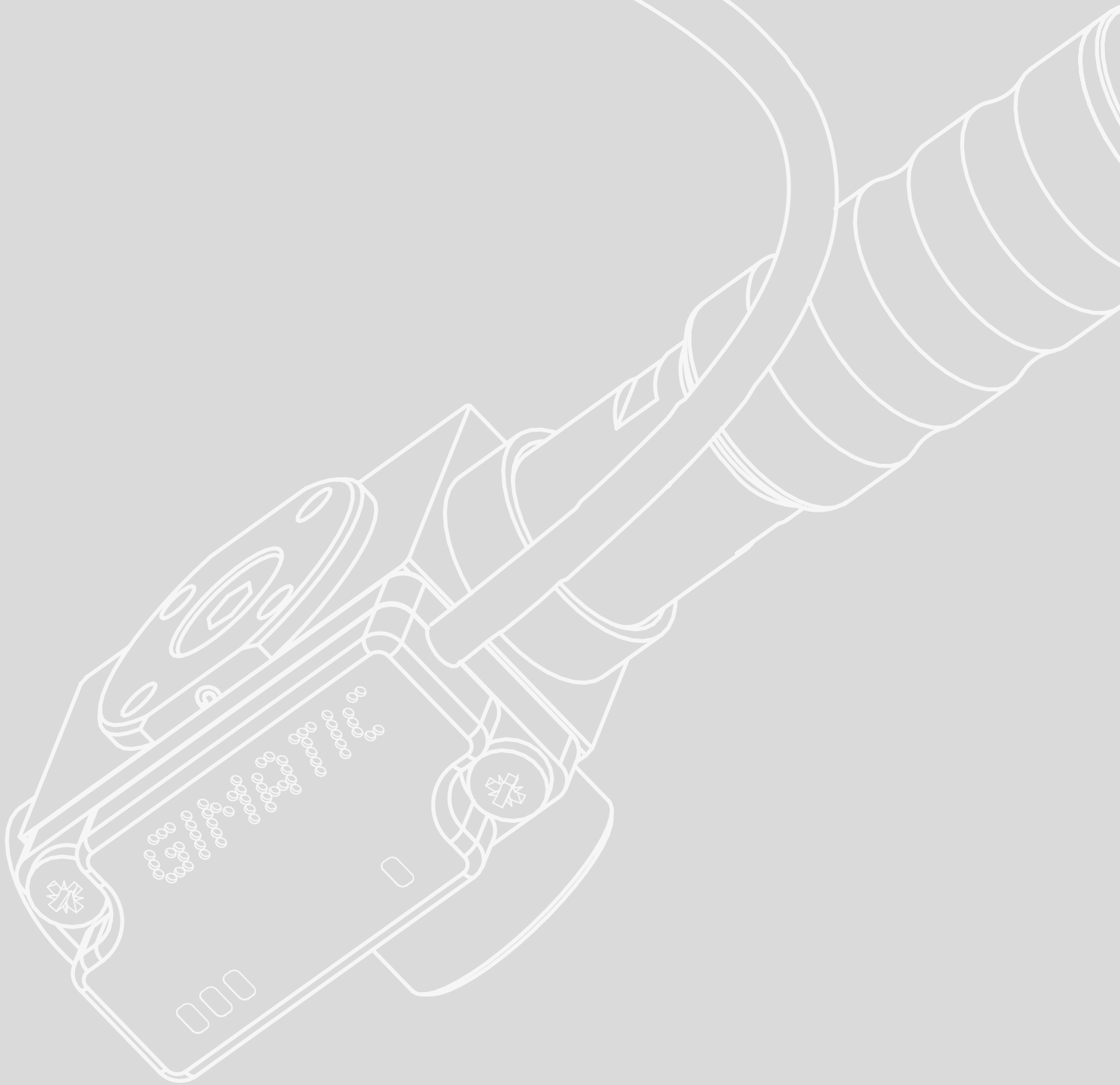

SUSPENSIONS AND SYSTEM ACCESSORIES



OVERVIEW OF SYSTEM ACCESSORIES

Introduction

Vacuum theory





Suction cups

Vacuum pumps

Customised solutions

Suspensions

System accessories

	System accessories		Notes
Suspensions	VSRT		Rotative suspensions with threaded body
	VSET		Non-rotative suspensions with integral elbow arms
	VSNTG		Threaded-body non rotative telescopic suspensions
	VSNTF		Non-rotative suspensions, with threaded body and brake
	VSRTF		Rotative suspensions, with threaded body and brake



Click for Quick Navigation

	System accessories		Notes
Ball joints	VAB		Ball joint for suction cups, with brake
Vacuum actuators	VAQ		Vacuum actuator
Vacuum switches	VACSD		Digital vacuum switch with color display, PNP outputs, NO or NC
	VACSM		Electromechanical vacuum switch preset to -30kPa, -50kPa, -70kPa, PNP or NPN digital output, NO or NC
	VACSW		Digital vacuum switch, preset to -30kPa, -50kPa, -70kPa, PNP or NPN. M8x1 3-pin male connector
	VACSE		Electromechanical vacuum switch, NO/NC, adjustable
	VACSP		Pneumatic vacuum switch, NC, adjustable
	AVG		Analog spring vacuum gauge
	Release systems	AQRV	
BNRV			Blow-off non-return valve, G1/8"
Vacuum filters	FILTR		Vacuum filter G1/8", G3/8", G1/2", G3/4" porosity 5 and 35 µm

Suspensions / VSRT

Rotative suspensions with threaded body

- Body and rod in anodised aluminium
- Rotating rod
- Operating pressure: -1 to 8 bar
- FDA-H1 food-grade grease

Introduction

Vacuum theory

Suction cups

Vacuum pumps

Customised solutions

Suspensions

System accessories



Application example

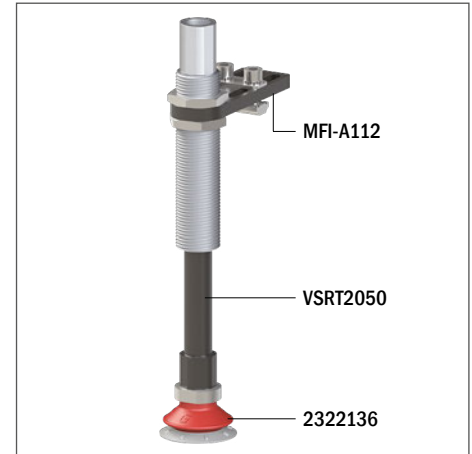

Technical data

	VSRT1010	VSRT1025	VSRT1420	VSRT1435	VSRT1620	VSRT1635	VSRT2025	VSRT2050
H [mm]	56	90.5	107	142	107	142	126	183.5
H1 [mm]	5	5	7	7	7	7	10	10
H2 [mm]	5	5	7	7	7	7	10	10
H3 [mm]	24.5	44	52	72	52	72	58	90.5
H4 [mm]	13.5	13.5	22	22	22	22	28	28
H5 [mm]	3.5	3.5	4	4	5	5	6	6
D1	M5	M5	G1/8"	G1/8"	G1/8"	G1/8"	G1/8"	G1/8"
D2	M5	M5	G1/8"	G1/8"	G1/8"	G1/8"	G1/8"	G1/8"
D3	M10x1	M10x1	M14x1.5	M14x1.5	M16x1	M16x1	M20x1.5	M20x1.5
CH1 [mm]	8	8	12	12	12	12	16	16
CH2 [mm]	8	8	12	12	12	12	16	16
CH3 [mm]	13	13	17	17	19	19	24	24
C [mm]	10	25	20	35	20	35	25	50
S2 [mm]	10	25	20	35	20	35	25	50
d [mm]	0	0	0	0	0	0	0	0
K [N/mm]	0.213	0.085	0.268	0.15	0.252	0.137	0.275	0.141
Weight [g]	12	16.5	37	47	46.5	58	90	118

Identification codes

Alphanumeric code	Description	Order code
VSRT1010	VSRT1010 suspension, M5 female, 10 mm useful stroke	9900001
VSRT1025	VSRT1025 suspension, M5 female, 25 mm useful stroke	9900002
VSRT1420	VSRT1420 suspension, G1/8" female, 20 mm useful stroke	9900003
VSRT1435	VSRT1435 suspension, G1/8" female, 35 mm useful stroke	9900004
VSRT1620	VSRT1620 suspension, G1/8" female, 20 mm useful stroke	9900005
VSRT1635	VSRT1635 suspension, G1/8" female, 35 mm useful stroke	9900006
VSRT2025	VSRT2025 suspension, G1/8" female, 25 mm useful stroke	9900007
VSRT2050	VSRT2050 suspension, G1/8" female, 50 mm useful stroke	9900008



Click for Pricing & Add to Cart

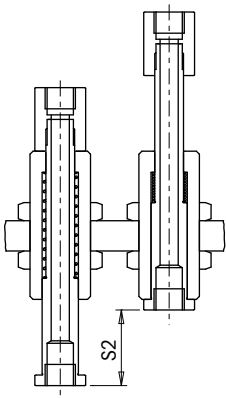
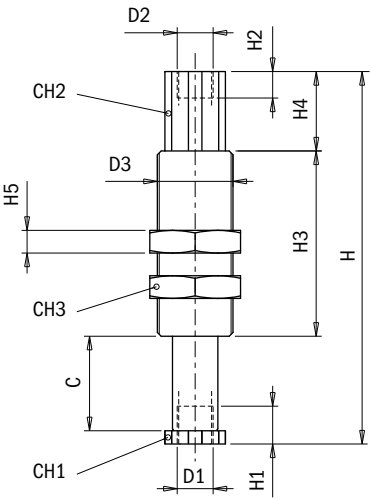

Suspensions / VSET

Non-rotative suspensions with integrated elbow arm and threaded body

- The angle is continuously adjustable between 0° and +/-90°
- External air supply
- Body and rod in anodised aluminium
- Anti-rotation rod with high load capacity
- Operating pressure: -1 to 8 bar
- FDA-H1 food-grade grease



Application example

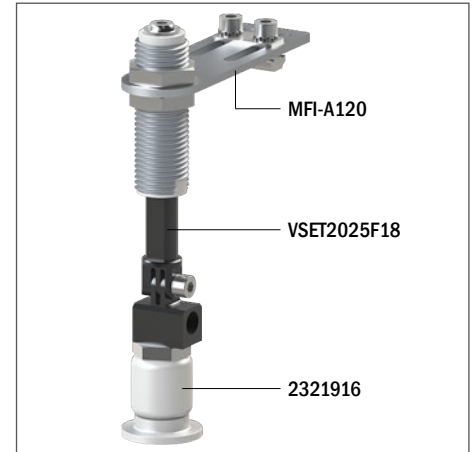

Technical data

	VSET1010F05	VSET1025F05	VSET1620F18	VSET1635F18	VSET2025F18	VSET2025F14	VSET2050F18	VSET2050F14
H [mm]	61.8	96.3	108.3	143.3	121.3	127.3	178.8	184.4
H1 [mm]	3.5	3.5	5.5	5.5	6.5	6.5	6.5	6.5
H2 [mm]	24.6	44.1	52.1	72.1	58.1	58.1	90.6	90.6
H3 [mm]	9	9	14.5	14.5	14.5	20.5	14.5	20.5
H4 [mm]	15	15	22	22	22	28	22	28
H5 [mm]	5.5	5.5	8.5	8.5	8.5	12	8.5	12
H6 [mm]	3.5	3.5	5	5	6	6	6	6
D1	M10x1	M10x1	M16x1	M16x1	M20x1.5	M20x1.5	M20x1.5	M20x1.5
D2	M5	M5	G1/8"	G1/8"	G1/8"	G1/4"	G1/8"	G1/4"
L [mm]	10	10	14	14	14	17	14	17
L1 [mm]	16	16	21.5	21.5	21.5	26	21.5	26
L2 [mm]	10.5	10.5	13	13	13	15	13	15
C [mm]	10	25	20	35	25	25	50	50
CH [mm]	13	13	19	19	24	24	24	24
S2 [mm]	10	25	20	35	25	25	50	50
d [mm]	0	0	0	0	0	0	0	0
K [N/mm]	0.213	0.085	0.268	0.150	0.275	0.275	0.141	0.142
Weight [g]	18	23	57	70	88	109	125	142

Identification codes		
Alphanumeric code	Description	Order code
VSET1010F05	VSET1010F05 suspension, M5 female, 10 mm useful stroke	9900009
VSET1025F05	VSET1025F05 suspension, M5 female, 25 mm useful stroke	9900010
VSET1620F18	VSET1620F18 suspension, G1/8" female, 20 mm useful stroke	9900011
VSET1635F18	VSET1635F18 suspension, G1/8" female, 35 mm useful stroke	9900012
VSET2025F18	VSET2025F18 suspension, G1/8" female, 25 mm useful stroke	9900013
VSET2025F14	VSET2025F14 suspension, G1/4" female, 25 mm useful stroke	9900014
VSET2050F18	VSET2050F18 suspension, G1/8" female, 50 mm useful stroke	9900015
VSET2050F14	VSET2050F14 suspension, G1/4" female, 50 mm useful stroke	9900016

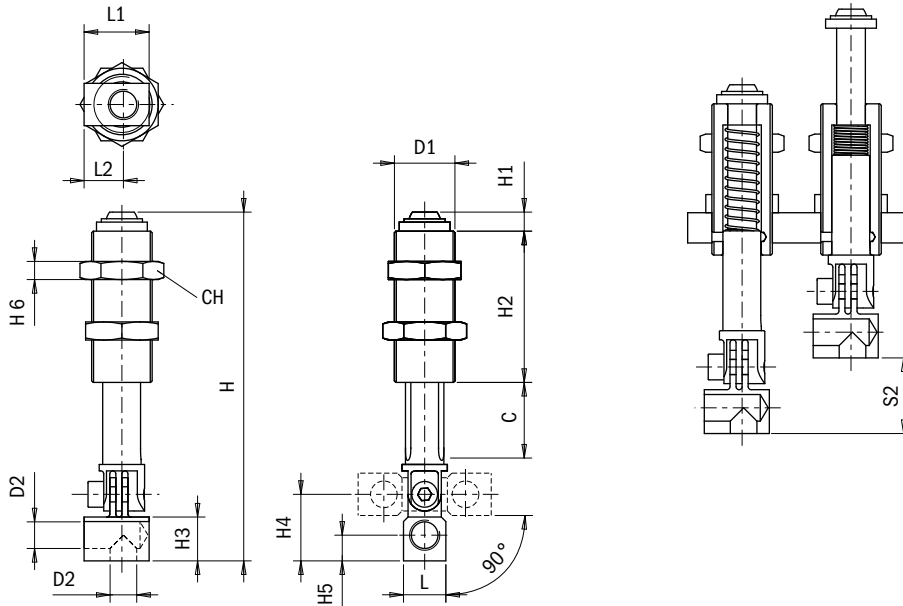

Suspensions / VSNTG

Threaded-body non rotative telescopic suspensions

- Body and rod in anodised aluminium
- Spring in stainless steel
- Anti-rotation rod with high load capacity
- Operating pressure: -1 to 8 bar
- FDA-H1 food-grade grease

Introduction

Vacuum theory

Suction cups

Vacuum pumps

Customised solutions

Suspensions

System accessories



Application example



Technical data

	VSNTG 1010	VSNTG 1025	VSNTG 1210	VSNTG 1225	VSNTG 1420	VSNTG 1435	VSNTG 1620	VSNTG 1635	VSNTG 2025F18	VSNTG 2025F14	VSNTG 2050F18	VSNTG 2050F14	VSNTG 2540	VSNTG 2580
H [mm]	56	90.5	65	99	107	142	107	142	126	126	183.5	183.5	173	263
H1 [mm]	5	5	5.5	5.5	7	7	7	7	10	10	10	10	11	11
H2 [mm]	5	5	5.5	5.5	7	7	7	7	10	10	10	10	11	11
H3 [mm]	24.5	44	30	49	52	72	52	72	58	58	90.5	90.5	90	140
H4 [mm]	13.5	13.5	17	17	22	22	22	22	28	28	28	28	28	28
H5 [mm]	3.5	3.5	4	4	4	4	5	5	6	6	6	6	8	8
D1	M5	M5	M5	M5	G1/8"	G1/8"	G1/8"	G1/8"	G1/8"	G1/4"	G1/8"	G1/4"	G3/8"	G3/8"
D2	M5	M5	M5	M5	G1/8"	G1/8"	G1/8"	G1/8"	G1/8"	G1/4"	G1/8"	G1/4"	G3/8"	G3/8"
D3	M10x1		M12x1		M14x1.5		M16x1		M20x1.5				M25x1.5	
CH1 [mm]	8	8	10	10	12	12	12	12	16	16	16	16	22	22
CH2 [mm]	8	8	10	10	12	12	12	12	16	16	16	16	22	22
CH3 [mm]	13	13	15	15	17	17	19	19	24	24	24	24	32	32
C [mm]	10	25	10	25	20	35	20	35	25	25	50	50	40	80
S2 [mm]	10	25	10	25	20	35	20	35	25	25	50	50	40	80
d [mm]	0	0	0	0	0	0	0	0	0	0	0	0	0	0
K [N/mm]	0.213	0.085	0.277	0.108	0.268	0.15	0.252	0.137	0.275	0.258	0.141	0.129	0.230	0.119
Weight [g]	12	16.5	20	26.5	37	47	46.5	58	90	86	118	115	205	275

Identification codes		
Alphanumeric code	Description	Order code
VSNTG1010	VSNTG1010 suspension, M5 female, 10 mm useful stroke	9900019
VSNTG1025	VSNTG1025 suspension, M5 female, 25 mm useful stroke	9900020
VSNTG1210	VSNTG1210 suspension, M5 female, 10 mm useful stroke	9900024
VSNTG1225	VSNTG1225 suspension, M5 female, 25 mm useful stroke	9900025
VSNTG1420	VSNTG1420 suspension, G1/8" female, 20 mm useful stroke	9900026
VSNTG1435	VSNTG1435 suspension, G1/8" female, 35 mm useful stroke	9900021
VSNTG1620	VSNTG1620 suspension, G1/8" female, 20 mm useful stroke	9900027
VSNTG1635	VSNTG1635 suspension, G1/8" female, 35 mm useful stroke	9900028
VSNTG2025F18	VSNTG2025F18 suspension, G1/8" female, 25 mm useful stroke	9900022
VSNTG2025F14	VSNTG2025 suspension, G1/4" female, 25 mm useful stroke	9900018
VSNTG2050F18	VSNTG2050F18 suspension, G1/8" female, 50 mm useful stroke	9900017
VSNTG2050F14	VSNTG2050 suspension, G1/4" female, 50 mm useful stroke	9900023
VSNTG2540	VSNTG2540 suspension, G3/8" female, 40 mm useful stroke	9900029
VSNTG2580	VSNTG2580 suspension, G3/8" female, 80 mm useful stroke	9900030

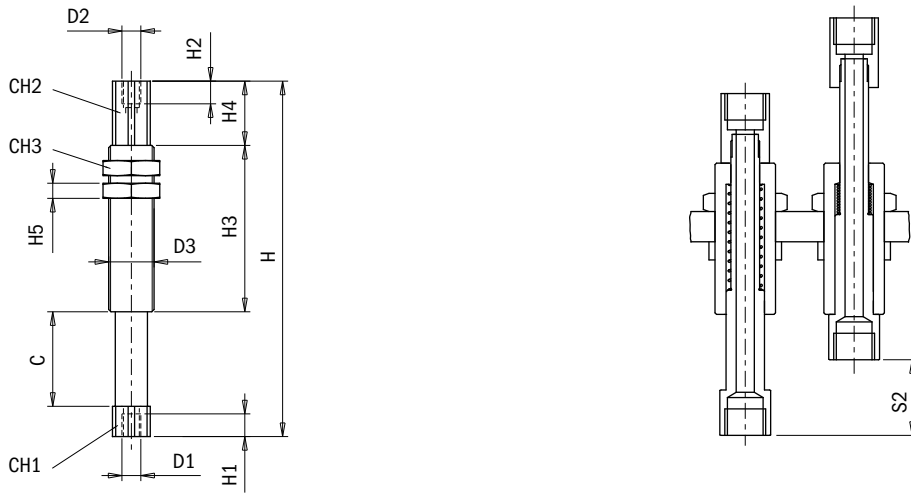

Suspensions / VSNTF

Non-rotative suspensions, with threaded body and brake

- Aluminium body and steel rod
- Pneumatically-driven device for rod lock (-NO) or unlock (-NC)
- Anti-rotation rod with high load capacity
- FDA-H1 food-grade grease
- Operating pressure: -1 to 8 bar
- Optional sensors (SS or SI type)



Application example

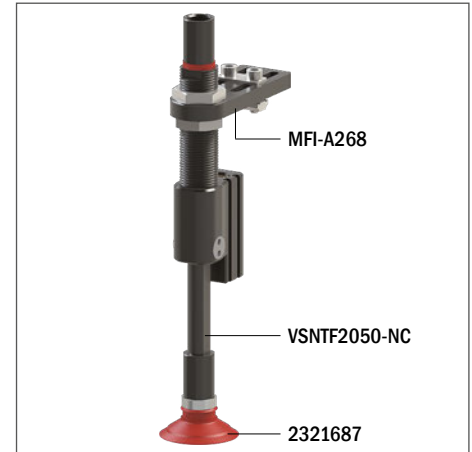

Technical data

	VSNTF2050-NC	VSNTF2050-NO	VSNTF30100-NC	VSNTF30100-NO
A [mm]	201.5		324.5	
B [mm]	26		28	
C [mm]	62.4		131	
D [mm]	40.1		–	
E [mm]	14.9		–	
F [mm]	55		65.5	
G [mm]	12		17	
H [mm]	31		40	
I [mm]	23		18	
J [mm]	10		13	
K	G1/4"		G3/8"	
L	M20x1.5		M30x1.5	
M [mm]	24		35	
N [mm]	50		100	
O [mm]	8.1		18	
CH1 [mm]	16		24	
CH2 [mm]	24		36	
Weight [g]	270		890	
Detection by magnetic sensor	✓	✓	✓	✓
Detection by inductive sensor	✓	✗	✓	✗
Operating pressure for locking	P1	4 ÷ 7 bar	–	3 ÷ 6 bar
Operating pressure for unlocking	P2	4 ÷ 8 bar	–	–
Braking force	200 N	80 N x P1 - 150 N	500 N	200 N x P1 - 400 N

Identification codes

Alphanumeric code	Description	Order code
VSNTF2050-NC	VSNTF2050-NC suspension, G1/4" female, 50 mm useful stroke	9900031
VSNTF2050-NO	VSNTF2050-NO suspension, G1/4" female, 50 mm useful stroke	9900032
VSNTF30100-NC	VSNTF30100-NC suspension, G3/8" female, 100 mm useful stroke	9900033
VSNTF30100-NO	VSNTF30100-NO suspension, G3/8" female, 100 mm useful stroke	9900034

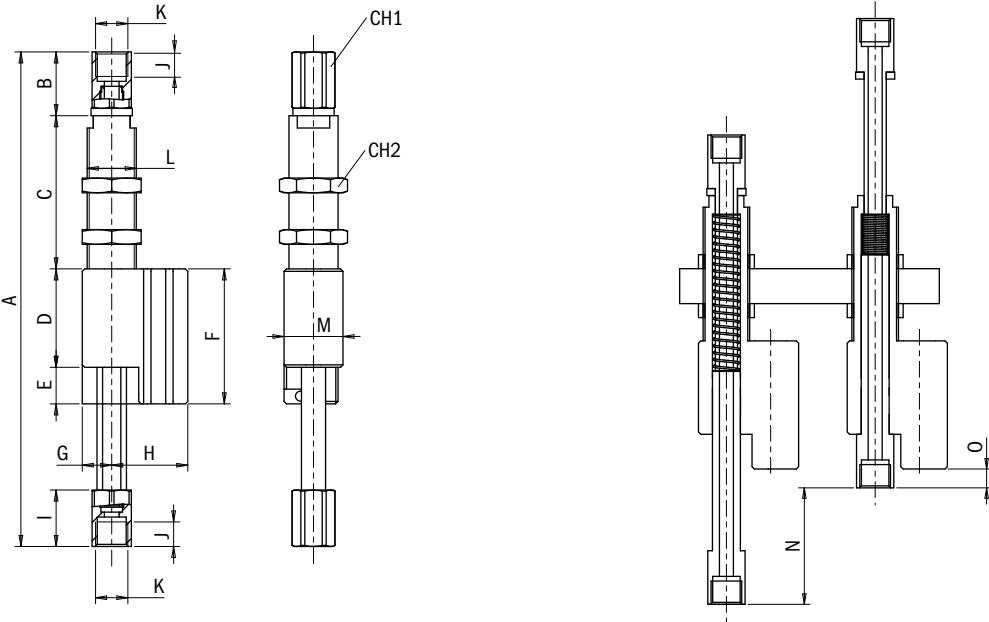

Suspensions / VSRTF

Rotative suspensions, with threaded body and brake

- Aluminium body and steel rod
- Pneumatically-driven device for rod lock (-NO) or unlock (-NC)
- Rotating rod
- FDA-H1 food-grade grease
- Operating pressure: -1 to 8 bar
- Optional sensors (SS or SI type)



Application example

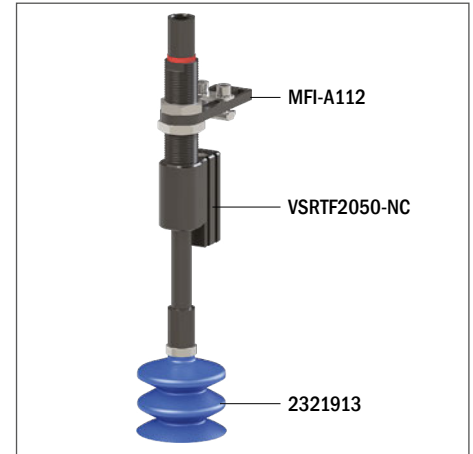

Technical data

		VSRTF2050-NC	VSRTF2050-NO	VSRTF30100-NC	VSRTF30100-NO
A [mm]		201.5		324.5	
B [mm]		26		28	
C [mm]		62.4		131	
D [mm]		40.1		–	
E [mm]		14.9		–	
F [mm]		55		65.5	
G [mm]		12		17	
H [mm]		31		40	
I [mm]		23		18	
J [mm]		10		13	
K		G1/4"		G3/8"	
L		M20x1.5		M30x1.5	
M [mm]		24		35	
N [mm]		50		100	
O [mm]		8.1		18	
CH1 [mm]		16		24	
CH2 [mm]		24		36	
Weight [g]		270		880	
Detection by magnetic sensor		✓	✓	✓	✓
Detection by inductive sensor		✓	✗	✓	✗
Operating pressure for locking	P1	–	4 ÷ 7 bar	–	3 ÷ 6 bar
Operating pressure for unlocking	P2	4 ÷ 8 bar	–	4 ÷ 8 bar	–
Braking force		200 N	80 N x P1 - 150 N	500 N	200 N x P1 - 400 N

Identification codes

Alphanumeric code	Description	Order code
VSRTF2050-NC	VSRTF2050-NC suspension, G1/4" female, 50 mm useful stroke	9900035
VSRTF2050-NO	VSRTF2050-NO suspension, G1/4" female, 50 mm useful stroke	9900036
VSRTF30100-NC	VSRTF30100-NC suspension, G3/8" female, 100 mm useful stroke	9900037
VSRTF30100-NO	VSRTF30100-NO suspension, G3/8" female, 100 mm useful stroke	9900038

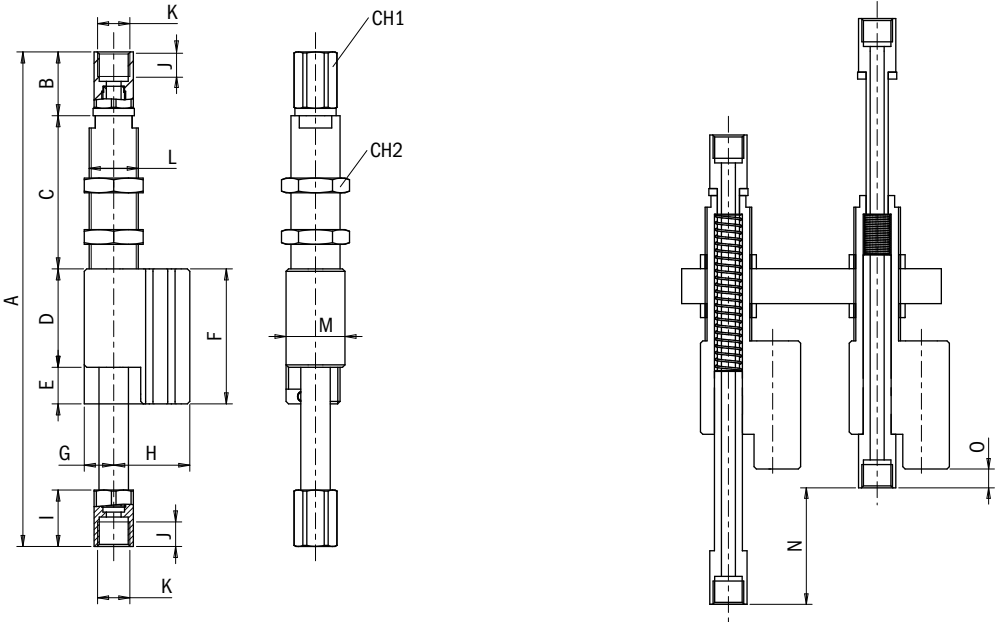

Ball joints / VAB

Ball joint for suction cups, with brake

- Pneumatically-driven device for joint lock (-NO) or unlock (-NC)
- Rotation fulcrum very close to the suction cup plane [1]
- Small lateral space taken upon rotation [2]
- Minimal slide of the suction cup upon picking-up
- FDA-H1 food-grade grease
- Operating pressure: -1 to 8 bar
- Two sizes available

Introduction

Vacuum theory

Suction cups

Vacuum pumps

Customised solutions

Suspensions

System accessories

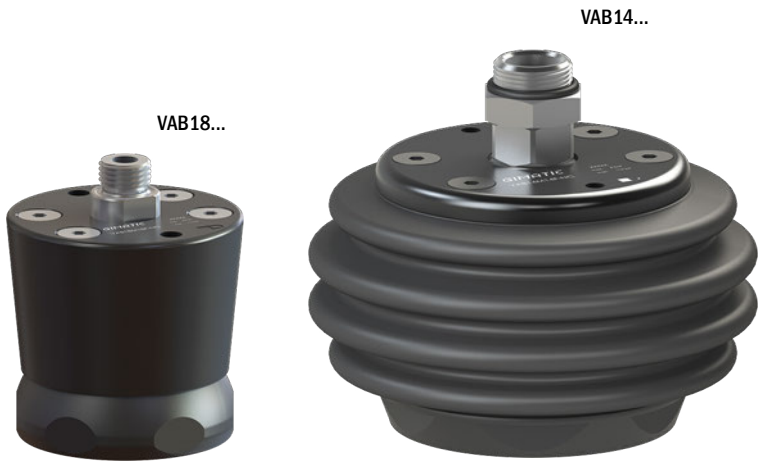

Application example

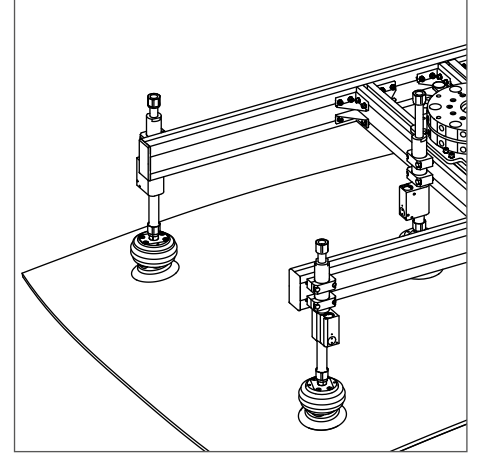

Technical data

		VAB18M18F-NC	VAB14M14F-NC	VAB18M18F-NO	VAB14M14F-NO
Fluid for lock / unlock		Filtered, lubricated / non lubricated compressed air			
Operating pressure for locking	P1	0 ÷ 8 bar	0 ÷ 8 bar	1 ÷ 8 bar	1 ÷ 8 bar
Operating pressure for unlocking	P2	4 ÷ 8 bar	3 ÷ 8 bar	0 ÷ 8 bar	0 ÷ 8 bar
Air consumption for locking		0 cm ³	0 cm ³	2.7 cm ³	4.3 cm ³
Air consumption for unlocking		0.4 cm ³	4.8 cm ³	0 cm ³	0 ÷ 4.8 cm ³
Pressure through the supply duct		-1 ÷ 8 bar			
Operating temperature		+41 - +140 °F			
Stroke		±21°			
Brake torque	Mb	1 Nm + 0.25 Nm x P1	2 Nm + 1 Nm x P1	0.25 Nm x P1	1 Nm x P1
Brake torque	Mt	0.8 Nm + 0.2 Nm x P1	1.8 Nm + 0.7 Nm x P1	0.2 Nm x P1	0.7 Nm x P1
Weight		152 g	420 g	147 g	410 g

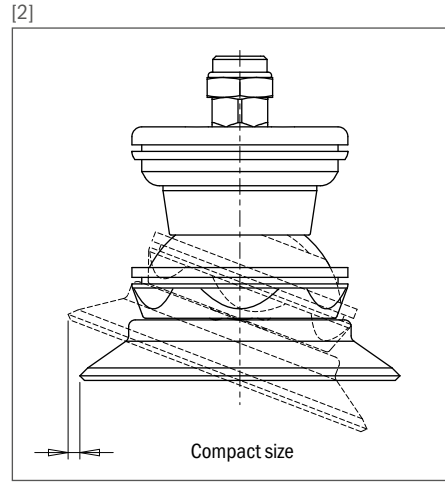
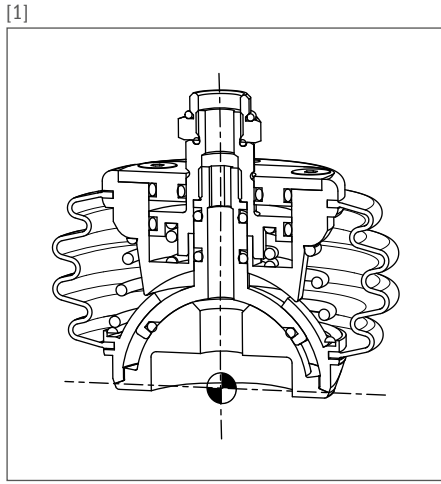

Identification codes

Alphanumeric code	Description	Order code
VAB18M18F-NC	Ball joint, G1/8" male, G1/8" female, NC	9900039
VAB14M14F-NC	Ball joint, G1/4" male, G1/4" female, NC	9900040
VAB18M18F-NO	Ball joint, G1/8" male, G1/8" female, NO	9900041
VAB14M14F-NO	Ball joint, G1/4" male, G1/4" female, NO	9900042



Click for Pricing & Add to Cart

VAB18...

VAB14...

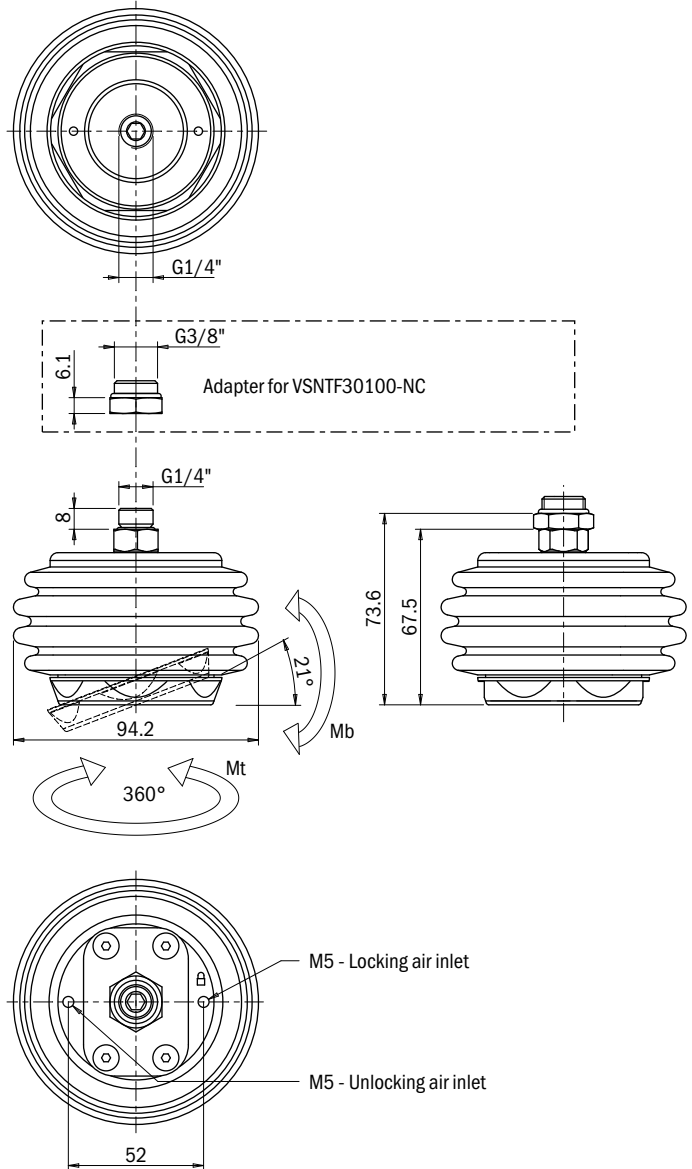
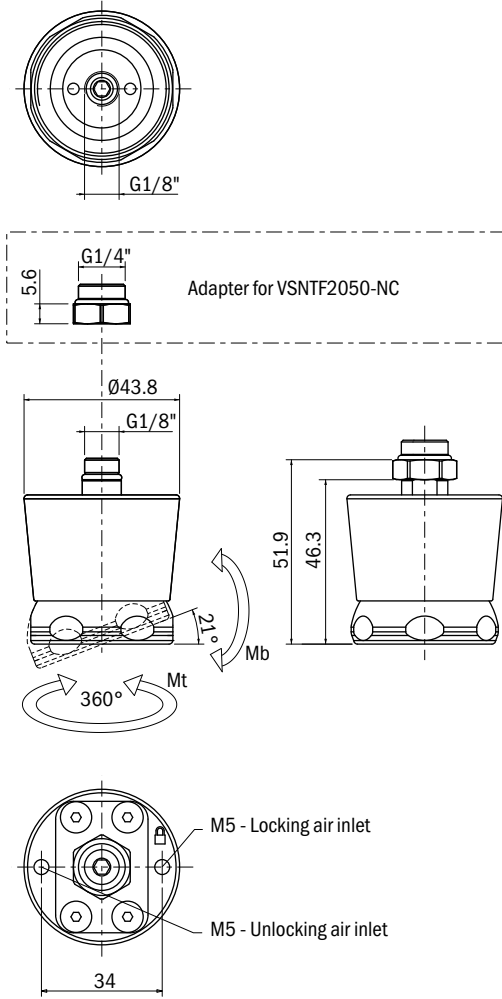

Vacuum actuator

- Operated by vacuum only
- The extension and retraction movements are automatically actuated
- The stroke is self-adjusting
- VAQN option for anti-rotation rod [3]
- The suction cup [1] must be ordered separately

Introduction

Vacuum theory

Suction cups



Application example

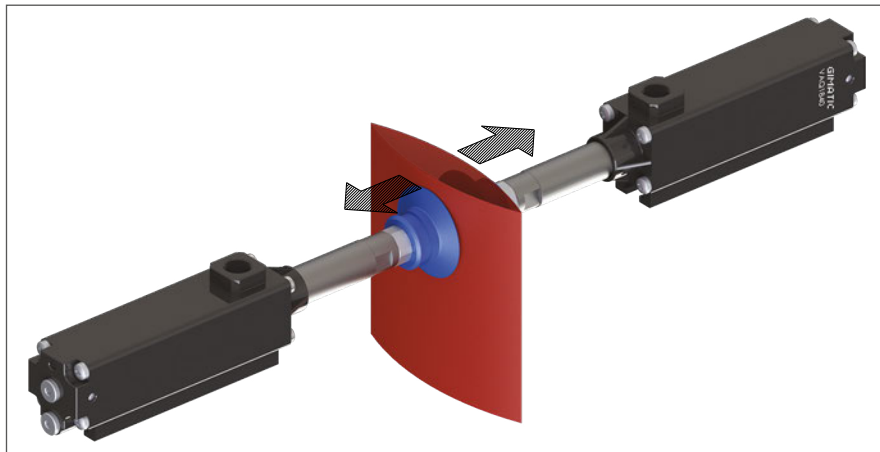

Vacuum pumps

Customised solutions

Suspensions

System accessories

Technical data

	VAQ1820	VAQ1840	VAQN1820	VAQN1840
Medium	Vacuum -0.3 to -1 bar			
Operating temperature	+50 - +104 °F			
Retraction force at -0.6 bar	10 N			
Maximum recommended load	5 N			
Total stroke	25 mm	55 mm	25 mm	55 mm
Stroke with full force	20 mm	40 mm	20 mm	40 mm
Weight	90 g	125 g	105 g	145 g

[1]



Identification codes

Drawing	Alphanumeric code	Description	Order code
A	VAQ1820	VAQ1820 vacuum actuator, G1/8" female, 20 mm useful stroke	9900043
A	VAQ1840	VAQ1840 vacuum actuator, G1/8" female, 40 mm useful stroke	9900044
B	VAQN1820	VAQN1820 vacuum actuator with anti-rotation rod, G1/8" female, 20 mm useful stroke	9900045
B	VAQN1840	VAQN1840 vacuum actuator with anti-rotation rod, G1/8" female, 40 mm useful stroke	9900046

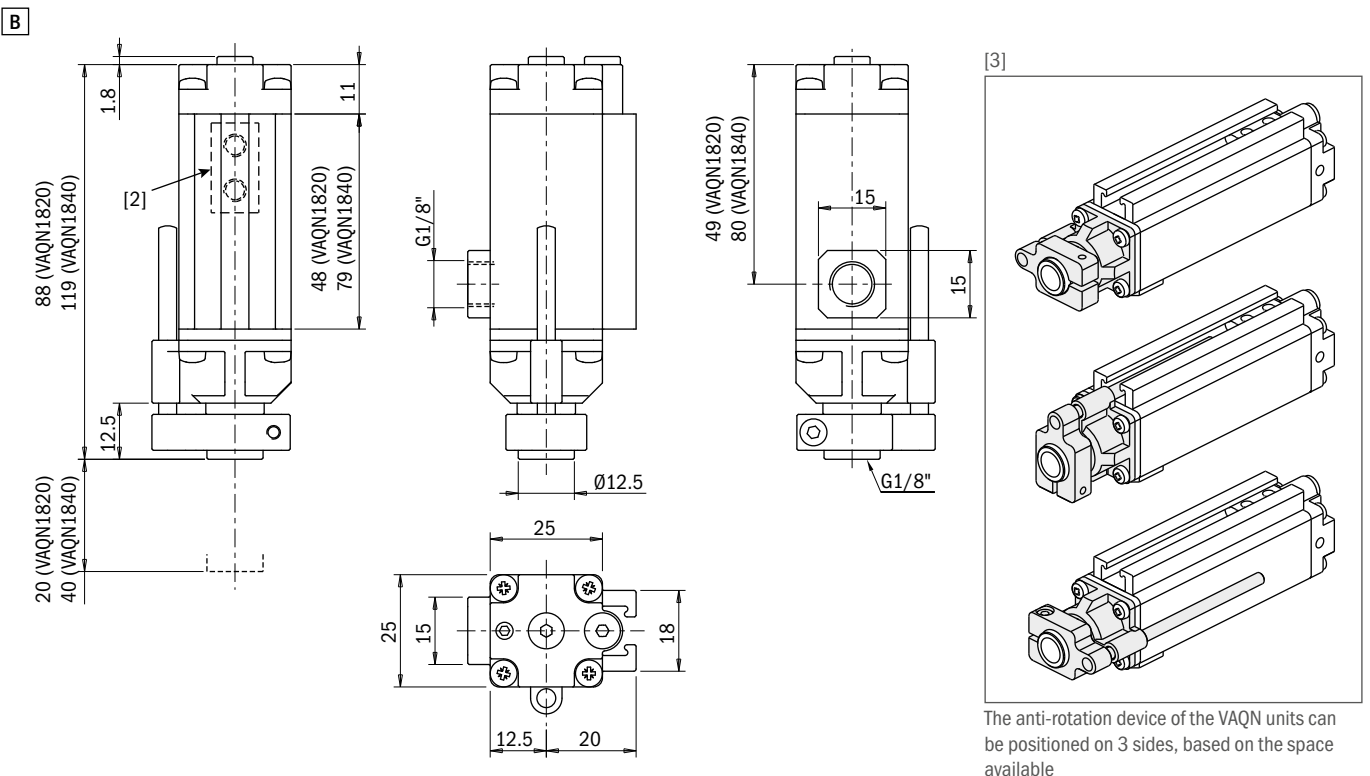
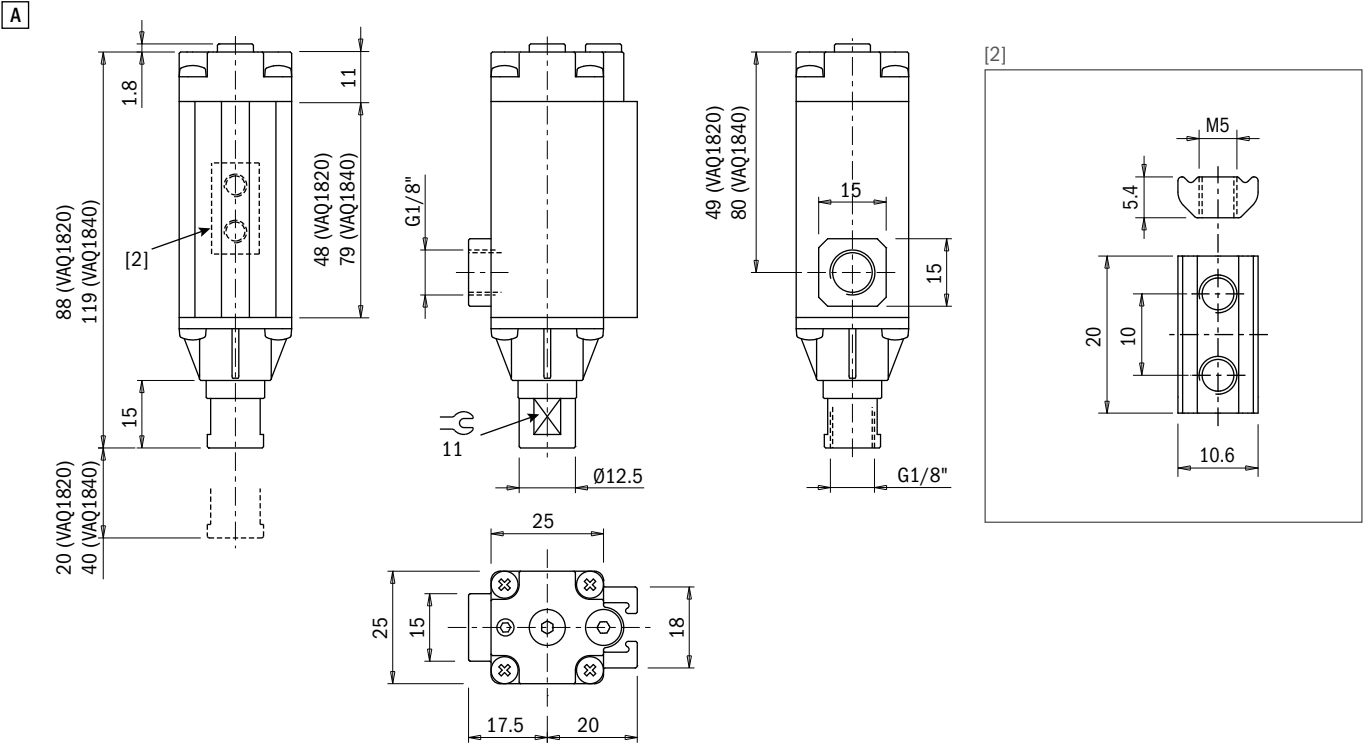

Vacuum switches / VACSD

Digital vacuum switch with display

- Easily readable color display
- Compact in size and lightweight
- 7 units of measurement available (kPa, MPa bar, psi, inHg, mmHg, kgf/cm²)
- 2 PNP outputs, NO or NC
- Double display to allow the simultaneous reading of actual values and pre-set values
- “Key lock” indicator light to prevent changes to default settings
- “Energy saving” indicator light with indication on display
- Fixing brackets included



Technical features

Max feed pressure	500 kPa
Weight	70 g
Temperature range	0 - +122 °F
Operating pressure range	0 ÷ -101.3 kPa
Output type	PNP NO/NC
Hysteresis	1 ÷ 8 kPa
Max current	125 mA
Current consumption	40 mA
Power supply	12 ÷ 24 Vdc
IP rating	IP40
Response time	≤ 2.5 ms

Identification codes

Alphanumeric code	Description	Order code
VACSDAN220-G	Digital vacuum switch with color display, with DIN connector	3030157

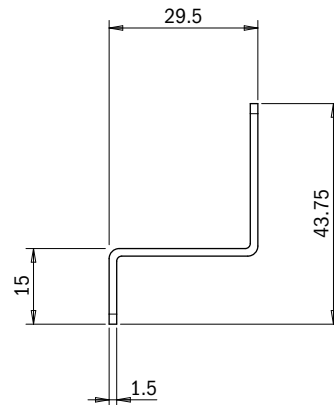
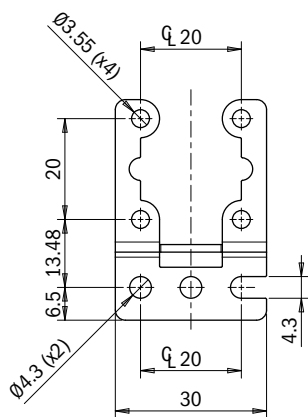
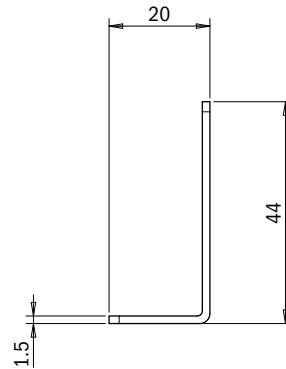
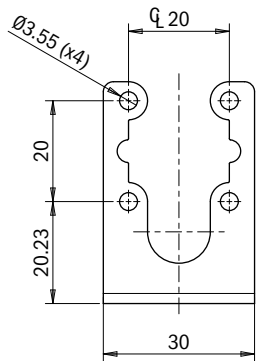
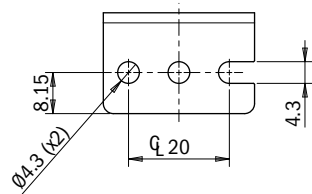
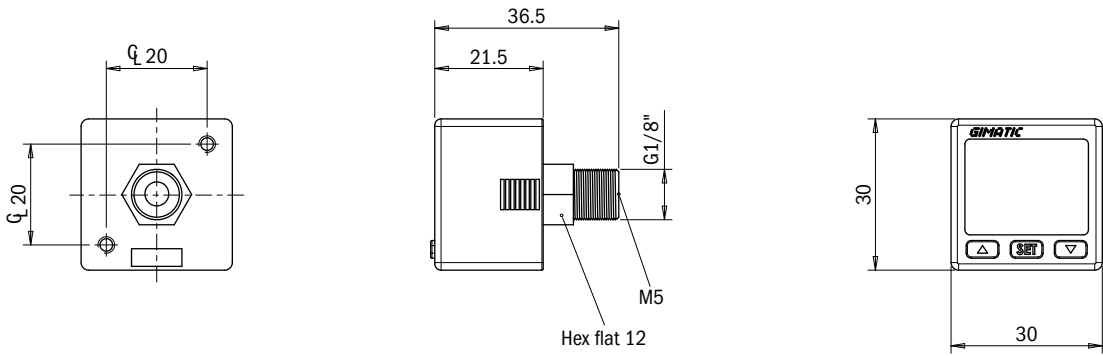

Vacuum switches / VACSM

Pre-set electromechanical vacuum switch

- Converts a vacuum signal into an electric digital signal
- Available in the version pre-set to -30, -50 and -70 kPa, with digital output
- PNP NO/NC or NPN NO/NC output function
- Possibility of connection with G1/8" or with Ø6 mm quick male connector



Technical features

Weight	5 g
Material	Pa, TPU, SS, CuZn (Au)
Temperature range	-13 - +185 °F
Vacuum connection	Ø6 mm – G1/8"
Output type	NPN - PNP
Hysteresis	6 ± 1 kPa
Electrical connection	M8 3-pin male connector
Power supply	12 ÷ 30 Vdc
IP rating	IP54
Response time	4 ms
Dimensions	16 x 16 x 22 mm
Setting tolerance	-3 ÷ +5 kPa
Max voltage drop (100 mA / 24 V inductive load)	0.055 V
Max current	100 inductive / 400 resistive mA

Identification codes			
Drawing	Alphanumeric code	Description	Order code
A	VACSM-G18-30	Pre-set electromechanical vacuum switch -30 kPa, G1/8" male, PNP/NPN, NO/NC	3030150
B	VACSM-T06-30	Pre-set electromechanical vacuum switch -30 kPa, with Ø6 mm male connection, PNP/NPN, NO/NC	3030151
A	VACSM-G18-50	Pre-set electromechanical vacuum switch -50 kPa, G1/8" male, PNP/NPN, NO/NC	3030152
B	VACSM-T06-50	Pre-set electromechanical vacuum switch -50 kPa, with Ø6 mm male connection, PNP/NPN, NO/NC	3030153
A	VACSM-G18-70	Pre-set electromechanical vacuum switch -70 kPa, G1/8" male, PNP/NPN, NO/NC	3030154
B	VACSM-T06-70	Pre-set electromechanical vacuum switch -70 kPa, with Ø6 mm male connection, PNP/NPN, NO/NC	3030155

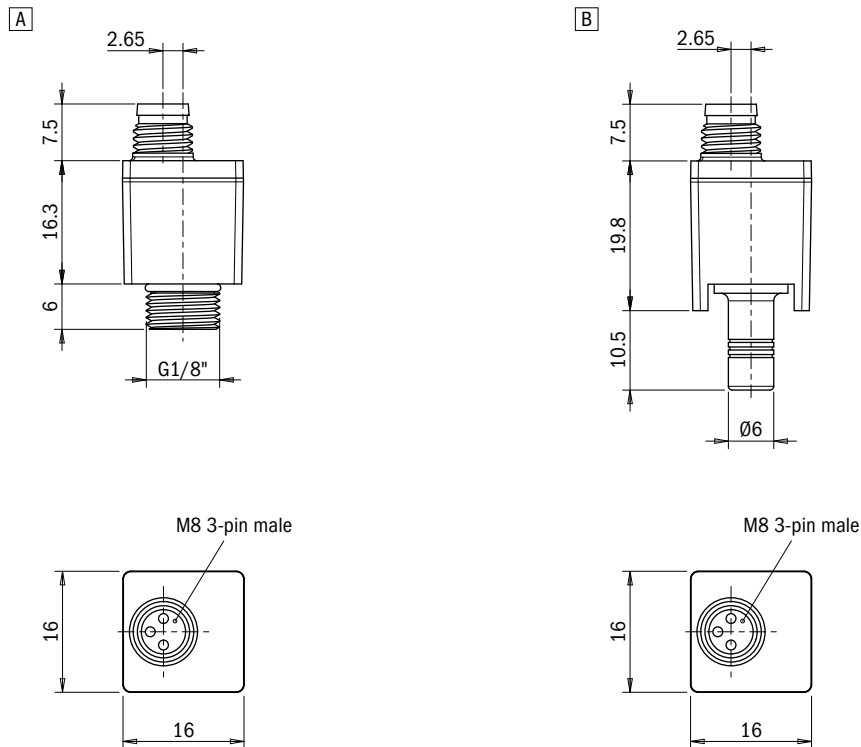

Identification codes		
Alphanumeric code	Accessories	Order code
CMGM800320CFGM8003	Extension cable with double M8 3-pin straight male/female connectors, 2 m long cable in PVC material	3030156
CFGM800325	M8 female connector with straight moulded PVC cable	3030146
CFGM800325P	M8 female connector with straight moulded PUR cable	3030148
CFGM890325P	M8 female connector with angled moulded PUR cable	3030149

Vacuum switches / VACSW

Pre-set vacuum switch with digital output

- Converts a vacuum signal into an electric digital signal
- Available in the versions with fixed setting -30, -50 and -70 kPa
- Compact in size and lightweight, reinforced glass fiber
- PNP or NPN output function
- Cable with M8x1 3-pin male connector, L=30 cm
- PWR with 3 LEDs (power supply: green), S1 (output: amber), L (vacuum leakage: red)
- Electrical connectors for wiring supplied separately as accessories L=2.5 m (PVC, PUR)



Technical features

Maximum overpressure	1 MPa
Weight	9 g
Material	PA66
Temperature range	-4 - +185 °F
Vacuum connection	Ø6 mm
Operating pressure range	0 ÷ -101.3 kPa
Output type	PNP - NPN
Hysteresis	7 kPa
Electrical connection	30-cm cable output with M8 3-pin male connector
Power supply	12 ÷ 24 Vdc (±10%)
IP rating	IP54
Response time	55 ms
Dimensions	40 x 20 x 15 mm

Identification codes		
Alphanumeric code	Description	Order code
VACSW-30-3N203-G	Pre-set vacuum switch, PNP -30 kPa, with digital output, cable L= 30 cm with M8x1 3-pin male connector	3030119
VACSW-50-3N203-G	Pre-set vacuum switch, PNP -50 kPa, with digital output, cable L= 30 cm with M8x1 3-pin male connector	3030120
VACSW-70-3N203-G	Pre-set vacuum switch, PNP -70 kPa, with digital output, cable L= 30 cm with M8x1 3-pin male connector	3030121
VACSW-30-3M203-G	Pre-set vacuum switch NPN -30 kPa with digital output, cable L= 30 cm with M8x1 3-pin male connector	3030122
VACSW-50-3M203-G	Pre-set vacuum switch NPN -50 kPa with digital output, cable L= 30 cm with M8x1 3-pin male connector	3030123
VACSW-70-3M203-G	Pre-set vacuum switch NPN -70 kPa with digital output, cable L= 30 cm with M8x1 3-pin male connector	3030124

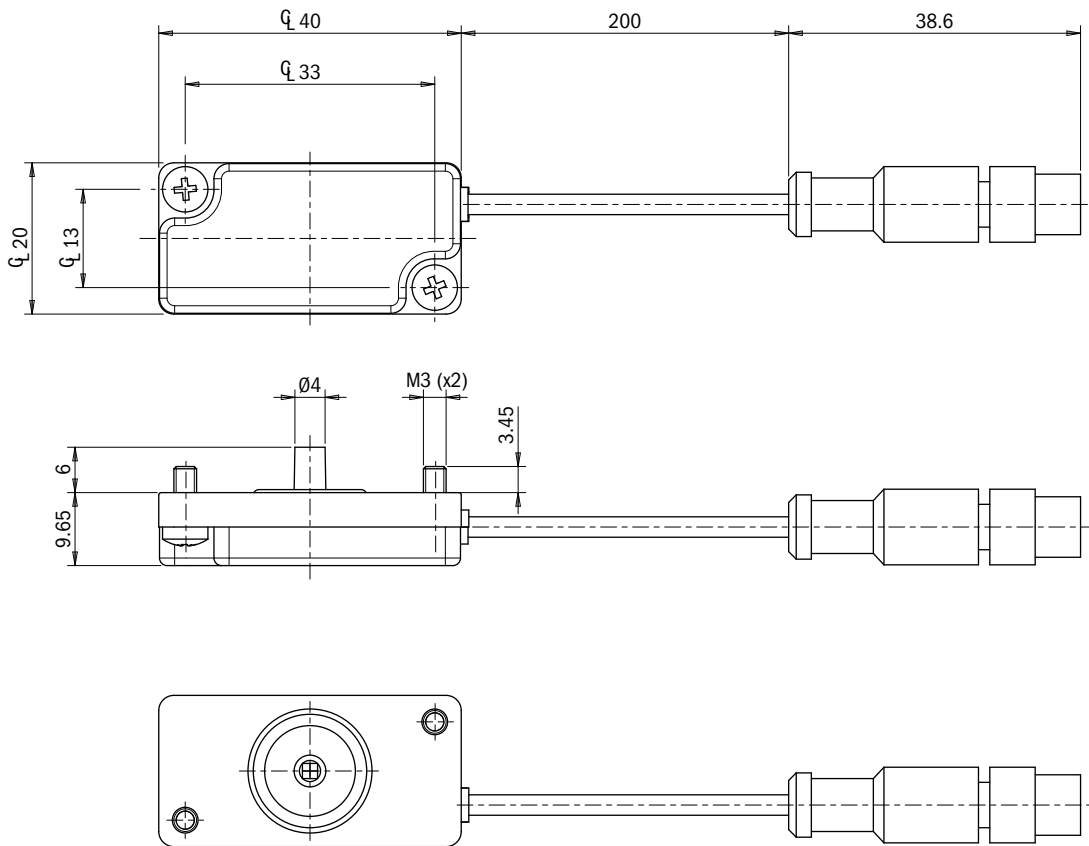

Identification codes		
Alphanumeric code	Accessories	Order code
CMGM800320CFGM8003	Extension cable with double M8 3-pin straight male/female connectors, 2 m long cable in PVC material	3030156
CFGM800325	M8 female connector with straight moulded PVC cable	3030146
CFGM800325P	M8 female connector with straight moulded PUR cable	3030148
CFGM890325P	M8 female connector with angled moulded PUR cable	3030149



Click for Pricing & Add to Cart

Vacuum switches / VACSE

Electromechanical vacuum switch, NO/NC, adjustable

- Converts a vacuum signal into an electric signal
- Adjustment of the switching threshold by means of screw and handle
- Version with M8 connector output or with free terminals

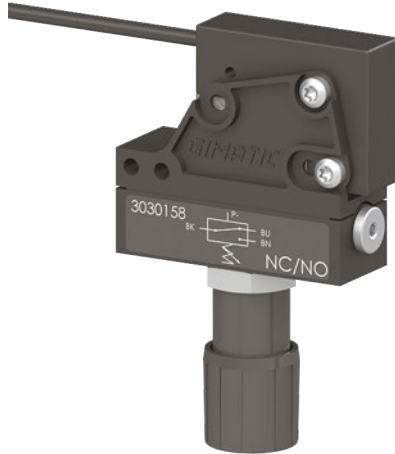

Technical features

	3030158	3030159
Mass	70 g	70 g
Material	CuZn, PA, PBTP, POM, PVC, SS, Al, Nitrile	CuZn, PA, PBTP, POM, PVC, SS, Al, Nitrile
Temperature range	-4 - +176 °F	-4 - +176 °F
Vacuum connection	M5	M5
Operating pressure range	-15 ÷ -95 kPa	-15 ÷ -95 kPa
Valve configuration	NC, NO	NC, NO
Hysteresis	12 kPa	12 kPa
Cable features	2.5 m long, 3x0.25 mm ²	300 mm with M8 3-pin male connector
IP rating	IP67	IP67
Max current	4 A	1 A
Max supply voltage	250 Vac	220 Vac
Dimensions	64.5 x 48 x 16.5 mm	64.5 x 48 x 16.5 mm

Identification codes

Alphanumeric code	Description	Order code
VACSE-4N225-G	Vacuum switch, VACSE series, NO/NC microswitch, adjustable with knob, 250 Vac, 4A, IP67, output for round cable, 2.5 m long, 3x0.25mm ²	3030158
VACSE-3N203-G	Vacuum switch, VACSE series, NO/NC microswitch, adjustable with knob, 220 Vac, 1A, IP67, 300 mm cable with M8 3-pin male connector	3030159

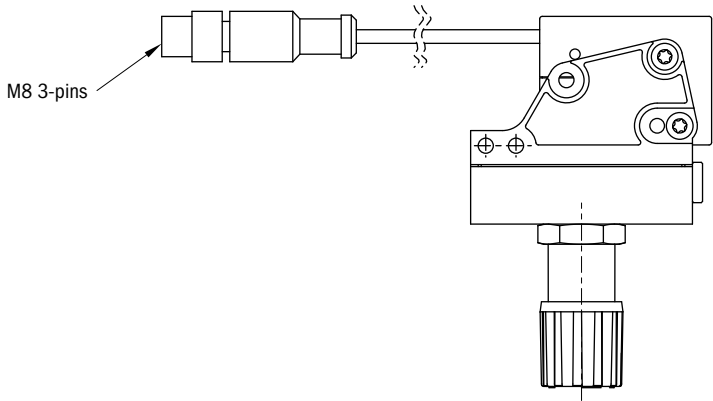
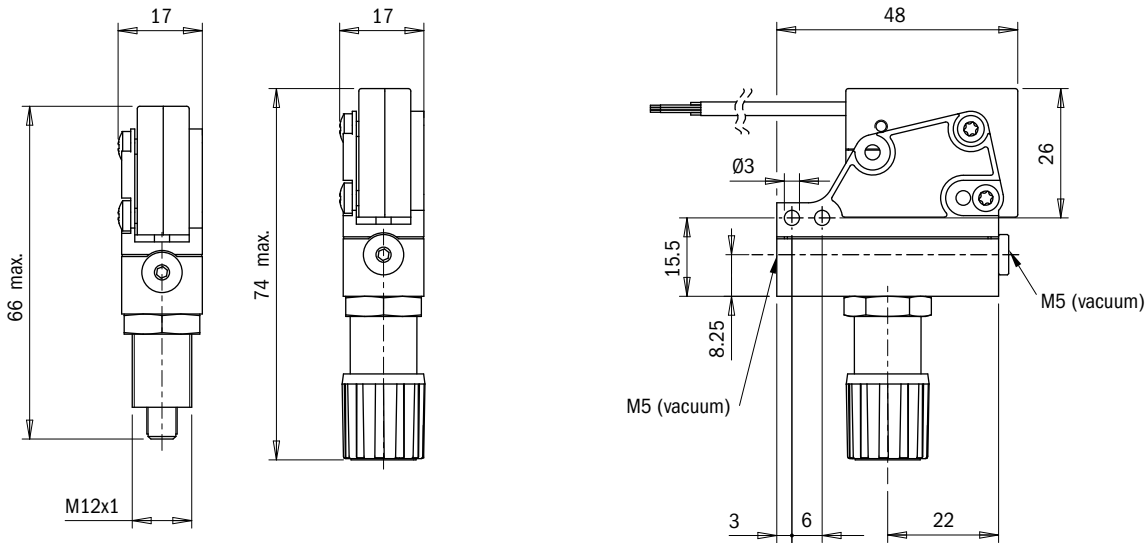
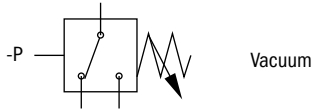

Vacuum switches / VACSP

Pneumatic vacuum switch, NC, adjustable

- Converts a vacuum signal into a pneumatic signal
- Adjustment of the switching threshold by means of screw and handle
- 4mm quick fittings for pneumatic signal



Technical features

Max feed pressure	0.8 MPa
Mass	50 g
Material	CuZn, PA, POM, SS, Al, Nitrile
Temperature range	+14 - +140 °F
Vacuum connection	M5
Operating pressure range	-15 ÷ -95 kPa
Valve configuration	NC
Hysteresis	12 kPa
Dimensions	60 x 54 x 16 mm

Identification codes

Alphanumeric code	Description	Order code
VACSP-NC-R	Pneumatic vacuum switch, NC, adjustable	3030160

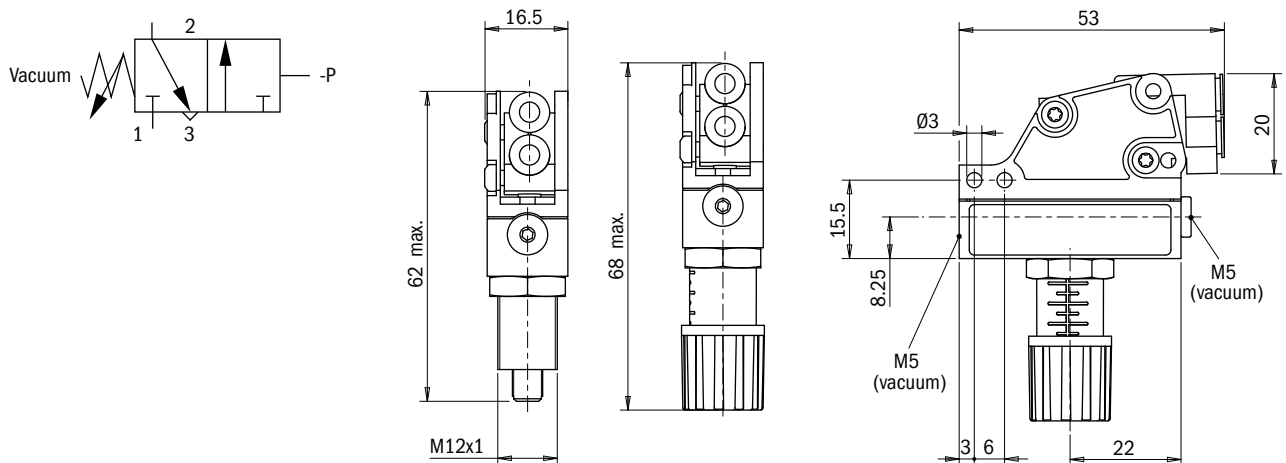

AQRV atmospheric quick release valve

- Quick release of the manipulated object through the accumulation of network pressure
- Simplifies the vacuum circuit, ON/OFF synchronized with the ejector
- A single 3/2 valve enables to control the ejector and the release device

Introduction

Vacuum theory

Suction cups

Vacuum pumps

Customised solutions

Suspensions

System accessories



Technical features

Pressure range	3 ± 0.6 MPa
Weight	11 g
Material	CuZn, TPU, NBR
Temperature range	+50 - +122 °F

Ordering information

Alphanumeric code	Description	Order code
AQRV	Atmospheric quick release valve	3100029

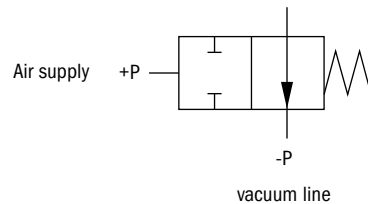
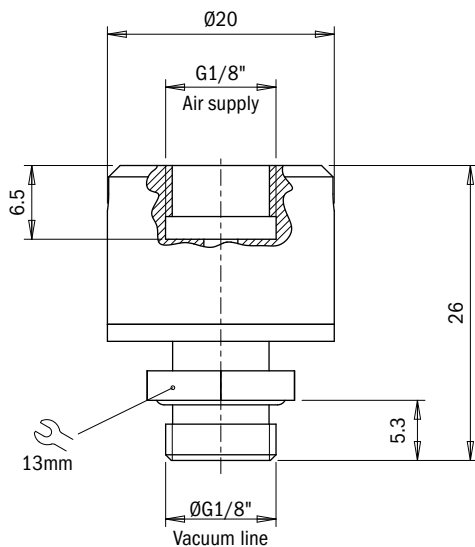

BNRV Blow-off non-return valve

- Ideal for decentralized applications where a quick release of the manipulated object is required
- Prevents suction through the blow-off lines
- Reduced feed pressure for full valve opening



Technical features	
Pressure range	0.1 ÷ 0.6 MPa
Weight	13 g
Material	CuZn, SS, Al, EPDM, nitrile (NBR)
Temperature range	-4 - +212 °F

Ordering information		
Alphanumeric code	Description	Order code
BNRV	Blow-off non-return valve	3100028

Click for Pricing & Add to Cart

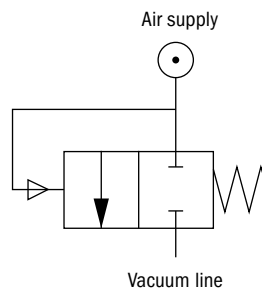
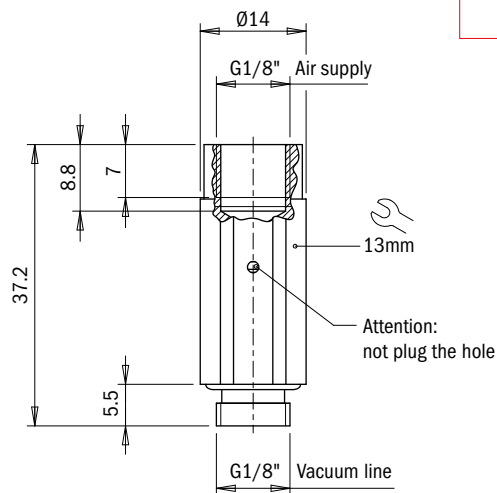

Vacuum filter

- Nylon vacuum filter
- Polyethylene filter cartridge with 5 µm and 35 µm porosity
- Prevents impurities from reaching the vacuum pump
- Threaded connections for easy installation



Technical features

Pressure range	0.2 MPa
Weight	50 ÷ 185 g
Material	PP, PA, PE
Temperature range	-4 - +176 °F
Porosity	5 ÷ 35 µm
Nominal flow rate	1.4 ÷ 85 NI/s
Internal volume	35 ÷ 675 cm ³
Filtering area	0.003 ÷ 0.023 m ²

Ordering information

Alphanumeric code	Description	Order code
FILTR-G018-05	Vacuum filter G1/8", 5 micron	3100008
FILTR-G038-05	Vacuum filter G3/8", 5 micron	3100009
FILTR-G034-05	Vacuum filter G3/4", 5 micron	3100011
FILTR-G012-05	Vacuum filter G1/2", 5 micron	3100010
CART-G1838-05	Filter cartridge 1/8" & 3/8", 5 micron	3100014
CART-G1234-05	Filter cartridge 1/2" & 3/4", 5 micron	3100015
FILTR-G018-35	Vacuum filter G1/8", 35 micron	3100018
FILTR-G038-35	Vacuum filter G3/8", 35 micron	3100019
FILTR-G034-35	Vacuum filter G3/4", 35 micron	3100021
FILTR-G012-35	Vacuum filter G1/2", 35 micron	3100020
CART-G1838-35	Filter cartridge 1/8" & 3/8", 35 micron	3100024
CART-G1234-35	Filter cartridge 1/2" & 3/4", 35 micron	3100025

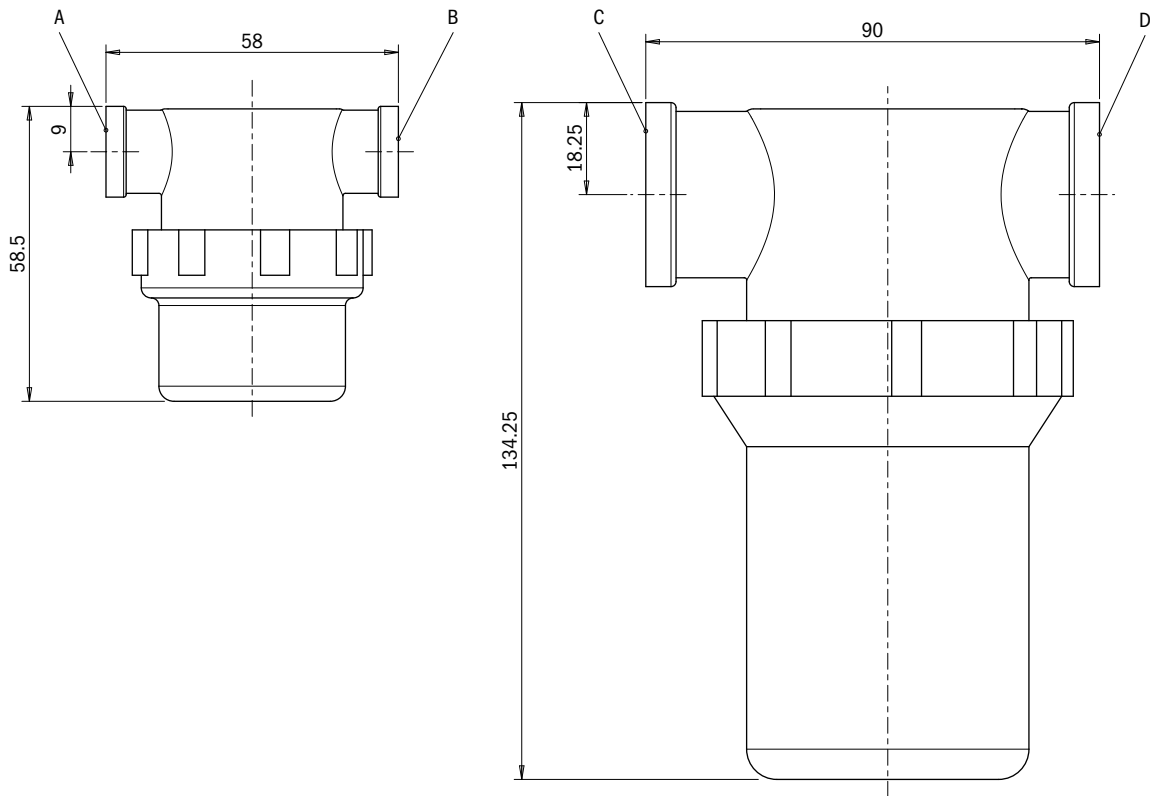

	FILTR-G018-05 FILTR-G018-35	FILTR-G038-05 FILTR-G038-35	FILTR-G012-05 FILTR-G012-35	FILTR-G034-05 FILTR-G034-35
A	G1/8"	G3/8"	—	—
B	G1/8"	G3/8"	—	—
C	—	—	G1/2"	G3/4"
D	—	—	G1/2"	G3/4"

Gimatic products sold by EMI Corp are subject to EMI's Terms & Conditions

EMI Terms and Conditions:

Acceptance: Sales by EMI Corp and its subsidiaries and divisions ("EMI") are expressly limited to these Terms and Conditions. All orders are subject to approval by EMI. Any purchase order, acknowledgement or other communication submitted by the Buyer which contains additional or contrary terms and conditions of sale are rejected.

Prices: Quoted prices are effective for 30 days from date of quotation; thereafter, prices are subject to change without notice. Prices listed in EMI's catalogs are current at time of publication and are subject to change without notice. Unless otherwise indicated, quantity discounts are offered only for like units ordered at the same time, on a single purchase order, for shipment per our standard delivery schedule. Any local, state or federal tax levied on the sale will be added to the purchase price and paid by the Buyer. Any portion of the price not paid when due will bear interest from the due date at the rate of 12% per annum or at the next lowest annual percentage rate as is permissible under any applicable usury law.

Terms: All orders are subject to credit approval by EMI.
For orders [and multiple purchase orders constituting a project] less than \$20,000: Net 30 Days.
For orders [and multiple purchase orders constituting a project] over \$20,000: 30% down with order, 70% net 30 days.

Cancellation: Orders may not be cancelled without EMI's prior written consent.

Shipment Schedule: All shipping dates are approximate. Shipment shown is based on available inventory, and engineering and production schedules at time of quotation. A better estimate of lead-times will be given at time of order placement. EMI will not be liable for any damage, loss of profit, or expenses arising out of delays in shipment or other nonperformance of this transaction caused by or imposed by (a) strikes, fires, disasters, riots, acts of God, (b) acts of Buyer, (c) shortages of labor, fuel, power, materials, supplies, transportation or manufacturing facilities, (d) government action, (e) subcontractor delay or (f) any other cause or condition beyond EMI's reasonable control. Additionally, EMI assumes NO responsibility for delivery performance, cost surcharges, or other fees imposed by a carrier, whether selected by Buyer or EMI.

Shipment: Shipment of products is ExW (ex-works), EMI facility, Jackson Center OH, or EMI facility, Wickliffe, OH. Packages weighing less than 75lbs. are shipped via small parcel service, pre-paid via EMI carrier of choice and added to the invoice unless otherwise specified. Shipments weighing over 75lbs., or oversized, are shipped Freight Collect via truck (common carrier) unless otherwise specified and agreed to by EMI. All shipments will be insured at the buyer's cost for the full value of the shipment unless buyer expressly waives insurance coverage in writing prior to shipment. All claims of shortages, defects or rejections must be made by the Buyer in writing within 15 days after receipt of the shipment. Claims of damage must be made to the carrier in accordance with its procedures.

Notes:

- (1) Shipments more than 75lbs. or shipments that are oversized are generally fully crated and/or skid mounted - dependent upon size and quantity.
- (2) In cases of skid or crate shipments, Buyer should specify a freight carrier with whom Buyer has an established account. Failure to specify a carrier can result in shipment delays or require payment to freight company before equipment can be unloaded at Buyer's dock.
- (3) EMI assumes no responsibility for shipments delayed or those received "Driver Collect" due to a trucking company not being specified by Buyer.
- (4) Truck shipments shipped Freight Prepaid and charged back will be invoiced to Buyer on a separate Freight Invoice plus a 10% handling fee with terms of net 15 days.

Delivery Loss and Damage Claims:

All claims must be made within 10 days of delivery. Claims must be filed with the freight carrier and must be initiated by the party who is responsible for payment of freight – EMI for Prepaid terms, the Buyer for Collect or Receiver terms. EMI will attempt to assist in the resolution of freight claims but shall not assume responsibility for Collect/Receiver initiated claims. Freight carriers may require shipping charges to be paid before issuing a credit on a claim and does not relieve the responsible party for payment of freight charges.

Proof of delivery requests must be received within 90 calendar days of shipment. After 90 days of shipment, the Buyer waives its right to dispute delivery of goods and agrees not to withhold payment against alleged non-delivery.

Export Control: Buyer acknowledges that EMI's products are subject to U.S. export controls and economic sanctions laws and regulations. Buyer agrees not to export, re-export, or retransfer EMI's products to any entity subject to US sanctions, embargoes, or trade restrictions, and to comply with all applicable U.S. export controls and economic sanctions laws and regulations regarding EMI products.

Export Shipment:

Buyer is responsible for the payment of all international shipping costs and taxes and duties including but not limited to: VAT, tariff, duty, taxes, customs clearance charges, freight forwarder fees and warehousing charges, and other charges related to international shipments. EMI is not responsible for delays due to freight transport, customs clearance, import/export holds, freight forwarder delays, or the Buyer not providing EMI necessary information for export documentation.

An Automated Export System (AES) filing is required for most exports exceeding \$2,500. An AES filing is often submitted by the U.S. Principal Party in Interest (USPPI), which is typically EMI. It can also be submitted by an authorized agent of the USPPI, such as a freight forwarder. If EMI authorizes the Buyer's freight forwarder or agent to file on behalf of EMI, EMI must receive a full copy of the AES filing submitted by the freight forwarder within three business days of receipt by the freight forwarder. If EMI does not receive a copy of the filing within three business days of shipment, EMI reserves the right to not authorize future power of attorney documentation to file the AES on behalf of EMI and to withhold further shipments pending EMI being provided all information necessary for AES filing.

Installation: Unless otherwise indicated, Buyer is solely responsible for safe installation of the equipment. In all cases, Buyer remains responsible for proper maintenance and guarding in accordance with applicable OSHA, federal, state, local, and other applicable regulations. **SERIOUS BODILY INJURY OR PROPERTY DAMAGE MAY RESULT FROM IMPROPER USE, GUARDING, OR MAINTENANCE OF EMI PRODUCTS OR PRODUCTS RESOLD BY EMI.**

Limited Warranty:

Conveyor Products: Conveyors (other than belting), motors, gear reducers and other drive components are guaranteed for three years from the date of shipment to be free from defects in material and workmanship when maintained in accordance with EMI manuals and operated under the conditions for which they were designed. Belting is guaranteed for 90 days under the same conditions.

EOAT Products: EMI, Gimatic, and Senvex EOAT products are guaranteed for 1 year from the date of shipment to be free from defects in material and workmanship when maintained in accordance with their respective product manuals and operated under the conditions for which they were designed. Wear items such as, but not limited to; vacuum cups, nipper blades, air hand expanders and inflators are not warranted.

Injection Molding Supplies: EMI manufactured accessory products for injection machines are guaranteed for 1 year from the date of shipment to be free from defects in material and workmanship when maintained in accordance with their respective product manuals and operated under the conditions for which they were designed. Wear and consumable items such as, but not limited to; non-return valves, nozzles, gate cutters, mold spray, oil sorbent, oil filters, etc. are not warranted.

Third party equipment or components are not warranted except where specified, but any third party warranties are, to the extent permitted, passed through to the Buyer. Damage, due to abuse, accident, misuse, modification, improper installation or maintenance, or improper electrical or mechanical applications are not covered by the Limited Warranty.

Furthermore, this Limited Warranty shall be void and of no effect whatsoever in the event the equipment is not used in accordance with and/or for the purpose provided, or if damages by reason of abnormal weather conditions, acts of God, falling objects, explosions, fire, riots, civil commotion, external forces, faulty or inadequate installation, acts of war, radiation, harmful fumes or foreign substances in the atmosphere, floods or use in structures not in accordance with accepted engineering standards.

Any claim for breach of the Limited Warranty must be made and presented to EMI in writing within a period of thirty (30) days following the discovery of the alleged defect, failing which the foregoing Limited Warranty shall be void and of no effect whatsoever. Alleged defective products shall be returned to EMI for inspection. Buyer must receive written authorization from EMI before returning any products and Buyer shall ship the products to EMI freight pre-paid at Buyer's expense. Authorization to return products is for purposes of inspection and shall not constitute acceptance of a product defect. Returned products must be suitably crated or packaged by the Buyer to prevent damage. EMI will inspect the returned products for defect. If inspection reveals a defect, Buyer's sole recourse for breach of warranty is the repair or replacement of defective products or the return of purchase price, at EMI's sole discretion. Repaired or replaced products are returned to the Buyer at no charge. If inspection reveals no defect, EMI will return the product to the Buyer at the Buyer's expense.

EMI Terms and Conditions:

EMI MAKES NO OTHER WARRANTIES, EXPRESS OR IMPLIED, WITH RESPECT TO THE EQUIPMENT OR THE USE OF THE EQUIPMENT OR THE PERFORMANCE OF THE EQUIPMENT. EMI SPECIFICALLY MAKES NO WARRANTY OF MERCHANTABILITY OR FITNESS FOR A PARTICULAR PURPOSE. EMI NEITHER ASSUMES, NOR AUTHORIZES ANY PERSON TO ASSUME FOR IT, ANY WARRANTY NOT SPECIFICALLY PROVIDED HEREIN.

Limitation of Liability: EMI's liability under this transaction will not exceed the purchase price. EMI IS NOT LIABLE FOR ANY CONSEQUENTIAL, SPECIAL OR INCIDENTAL DAMAGES ARISING OUT OF OR RELATING DIRECTLY OR INDIRECTLY TO THIS TRANSACTION OR AS A RESULT OF THE SALE OF PRODUCTS OR EQUIPMENT, A BREACH OF THE WARRANTY PROVIDED HEREIN OR ANY USE OR MISUSE OF THE PRODUCTS OR EQUIPMENT.

Indemnification: Buyer agrees to indemnify and hold EMI harmless and defend EMI from and against all liability and expense based upon bodily injury, property damage or economic loss, arising, directly or indirectly, from the production, sale, re-sale, transportation, storage or the use of products sold by the Buyer, except as caused by the sole negligence of EMI.

Returns: Buyers may request a product be returned to EMI for credit of purchase price. A material return number (RMA#) must be obtained before any products may be sent back to EMI. Buyer understands that obtaining an RMA number does not constitute EMI's acceptance of the return. Buyer may return the products via freight carrier of their choice, and shipping must be at Buyers cost (pre-paid).

Buyer must package the products suitably to prevent damage to the products being returned. An inspection of the returned products will be conducted to determine if full or partial credit will be issued against the original purchase price. If the item is returned in the same condition as it was originally sent, and sealed in the original packaging that it was shipped from EMI a re-stocking fee or other credit adjustment is typically waived. Built to order, customized, and non-standard or other non-stock parts including but not limited to alterations to the product that Buyer make are subject to a re-stocking fee and may not qualify for return credit.

Law: This transaction is governed and construed in accordance with the laws of the State of Ohio (exclusive of any conflict of laws provision) and the Buyer consents and submits to the jurisdiction of any state court located in Shelby County, Ohio. If any provision of these Terms and Conditions is deemed to be held invalid, illegal, unenforceable, or inoperative, the balance of these Terms and Conditions will remain in full force and effect as if such revision had not been included.



Inventory in Ohio!

- Upfront, online pricing with E-commerce ease of buying.
- Local sales and engineering support throughout the USA, Canada, and Mexico by EMI employees.



www.EMInc.com/Gimatic

Sales & Design Engineering

gimaticinfo@emicorp.com

sales@emicorp.com

Phone: 216-535-4848

28300 Euclid Ave. Wickliffe, Ohio 44092



EMI Mexico

ventas@emicorp.com

Teléfono: +52 (442) 349-7646

Avenida Industria de la Construcción #511 Int. 5,6,7

Parque Industrial Querétaro

Santa Rosa de Jáuregui, Querétaro 76220

© 2022 Gimatic / EMI Corporation. All Rights Reserved.

No parts of this publication may be reproduced or transmitted in any form or by any means, electronic, mechanical, photocopying or otherwise, without the prior written permission of EMI Corp.

We reserve the right to make alterations.



Via Enzo Ferrari, 2/4
25030 Roncadelle (BS) ITALY
www.Gimatic.com