

## EA Chain Drive - Assembled and Exploded View

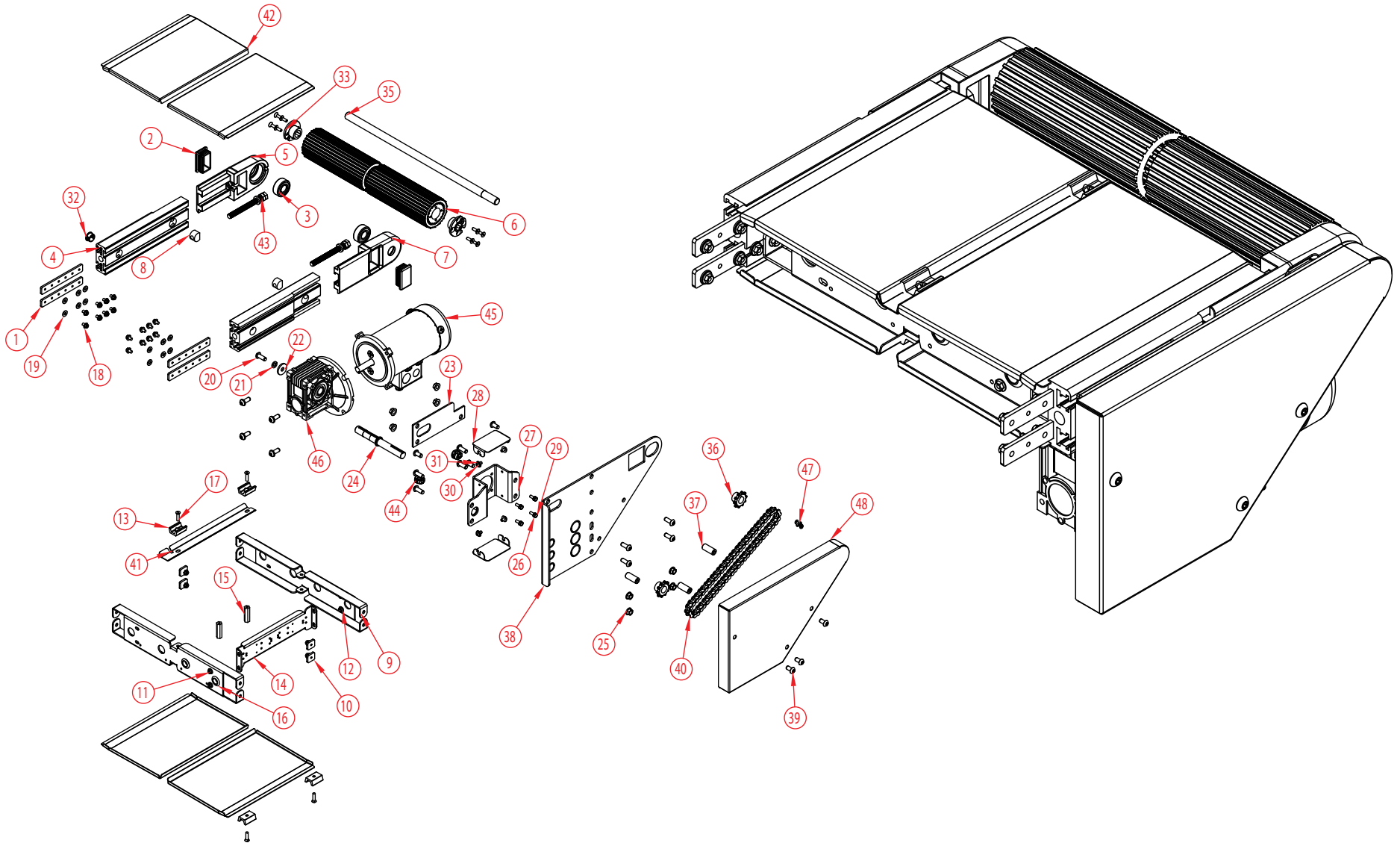

Section VIII. Parts Lists and 3-D Drawings

**EA Chain Drive - Parts List**

	QTY.	PART NO.	DESCRIPTION		QTY.	PART NO.	DESCRIPTION
1	4	2X-27-4	FRAME CONNECTION PLATE	25	8	CP-3299	SERRATED FLANGE NUT 0.375-16 BLACK OXIDE
2	2	CP-3532	PLASTIC CAP 1.500x2.500 RECTANGLE	26	4	CP-7031	WASHER, M6, EXTERNAL TOOTH LOCK WASHER
3	2	CP-4592	20MM BALL BEARING SELF ALIGNING	27	1	2X-14-7-1	MOUNTING BRACKET FOR 040 REDUCER
4	2	2X-44-2-2	FRAME SIDE FOR DRIVE HEAD	28	2	2X-14-7-3	COVER FOR MOUNTING BRACKET
5	1	2X-14-1-2	TAKE-UP BRACKET FOR EA CONVEYOR	29	4	CP-7337	HEX HEAD SCREW M6 x 16
6	1	2X-10-3-W (CF)	DRIVE PULLEY FOR DIRECT DRIVE	30	4	CP-4536	1/4-20 X 1/2" BLACK OXIDE TORX BUTTON CAP SCREW
7	1	2X-14-1-3	TAKE-UP BRACKET FOR EA CONVEYOR	31	4	CP-3343	LOCK WASHER .250 SPLIT RING
8	2	2X-55-1	TAKE-UP NUT FOR EA CONVEYOR	32	1	CP-1240	7/8" GROOVE DIAMETER RUBBER GROMMET
9	2	2X-41-2-W (CF)	FRAME BRACE FOR DRIVE HEAD	33	2	2X-14-8	END CAP FOR DIRECT DRIVE PULLEY
10	4	2X-27-5-100	INSIDE FRAME NUT	34	8	CP-322	HEX SOCKET FLAT HEAD SCREW .250-20 x .750
11	4	CP-3067	HEX SERRATED FLANGE SCREW 0.250-20x0.5" ZINC PLATED	35	1	2X-21-8-W (CF)	DRIVE PULLEY SHAFT
12	4	CP-3068	HEX FLANGE NUT 0.25-20	36	2	CP-2662	SPROCKET 40B10 x .750
13	4	2X-19-1	SLIDE BED RETAINER OR CLAMP	37	3	3E-41-1062-150	CROSS BRACE
14	1	2X-29-1	INSIDE CONTROL SUPPORT	38	1	2X-14-9-1-R	UNDERNEATH MOTOR BRACKET
15	2	2X-55-3	SLIDE TRAY HOLD DOWN NUT	39	6	CP-4533	3/8-16 X 3/4" BLACK OXIDE TORX BUTTON CAP SCREW
16	2	CP-2376	RUBBER GROMMET	40	1	3E-40-74-3000	#40 ROLLER DRIVE CHAIN
17	4	CP-259	SLOTTED FLAT HEAD SCREW .250-20 x 1.000	41	1	2X-45-11	SLIDE BED WATER GUARD
18	20	CP-4564	HEX SERRATED FLANGE SCREW 0.250-20x0.375" ZINC PLATED	42	4	2X-45-1-W-1300 (CF)	SLIDE BED FOR STANDARD FRAME
19	16	CP-654	FLAT WASHER .250 SAE	43	2	2X-232-1	WELDMENT FOR TAKE-UP BOLT
20	13	CP-4534	3/8-16 X 1" BLACK OXIDE TORX BUTTON CAP SCREW	44	2	EL-7245	CORD GRIP
21	5	CP-3345	LOCK WASHER .375 SPLIT RING	45	1	EL-128B	MOTOR
22	1	CP-3393	3/8" FLAT WASHER	46	1	CP-7560	MOTOVARIO GEARBOX NMRV-040-60-56C
23	1	2X-14-9-2	UNDERNEATH BRACKET SPACER	47	1	CP-1297	#40 CONNECTOR LINK
24	1	2X-21-9	SINGLE OUTPUT SHAFT FOR EA CONVEYOR	48	1	2X-208-4-X (CF)	CHAIN GUARD WELDMENT