

EMI Gripper Kit – 2-Jaw SX for Industrial Cobots

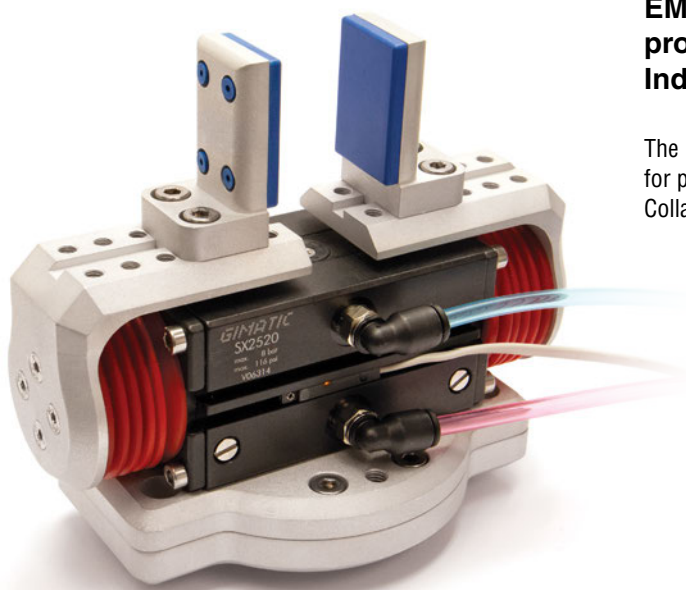

EMI has adapted a cost-effective and industry-proven gripper to expand the capabilities of Industrial robots.

The Pneumatic SX Gripper Kit by EMI offers the ideal solution for part handling, machine tending and secondary operations in Collaborative Industrial Robot applications.

Quick# 8002
 Part# CRK-SX2520-A
KIT PRICE: \$995.00



Part#	SX2510	SX2520	SX4020	SX4040	SX5030	SX5060	SX6340	SX6380
Quick#	7164	7165	7166	7167	7168	7169	7170	7171
Medium	Filtered, lubricated / non-lubricated compressed air							
Operating pressure range	30–116 psi							
Total Opening force at 87 psi	112lbf	112lbf	292lbf	292lbf	472lbf	472lbf	764lbf	764lbf
Total Closing force at 87 psi	87lbf	87lbf	225lbf	225lbf	360lbf	360lbf	562lbf	562lbf
Stroke (±0.5mm)	10mm	20mm	20mm	40mm	30mm	60mm	40mm	80mm
Opening / closing time without load	0.03s	0.05s	0.03s	0.08s	0.06s	0.10s	0.20s	0.30s
Repetition accuracy	0.05mm							
Mid-stroke detection capability	No	Yes, with Magneto-resistive sensor						
Weight of Gripper (Only)	260g	310g	750g	900g	1300g	1700g	2800g	3500g

SX Parallel, Self-Centering Two-Jaw Gripper Kit:

- This versatile kit can be adapted to other SX Gripper sizes with various strokes and gripping force upon request.
- The precision machined components make this industrial gripper rugged, while offering a high degree of repeatability.
- The SX gripper is completely sealed – IP67 protection class.
- Double acting with 5/2 solenoid valve and cable management clamps.
- Includes 1 magnet sensor for part detection.
- The included interface plate mounts directly to any robot with an ISO-9409-1-50-4-M6 tool flange. Contact EMI if you need a different interface plate.
- Includes 3 sets of finger pads: silicone, rubber, HNBR.
- CRK-SX2520-A Mass: 735g (subject to change per configuration).



EMI Gripper Kit – 2-Jaw SX for Industrial Cobots

Easy installation and programming!

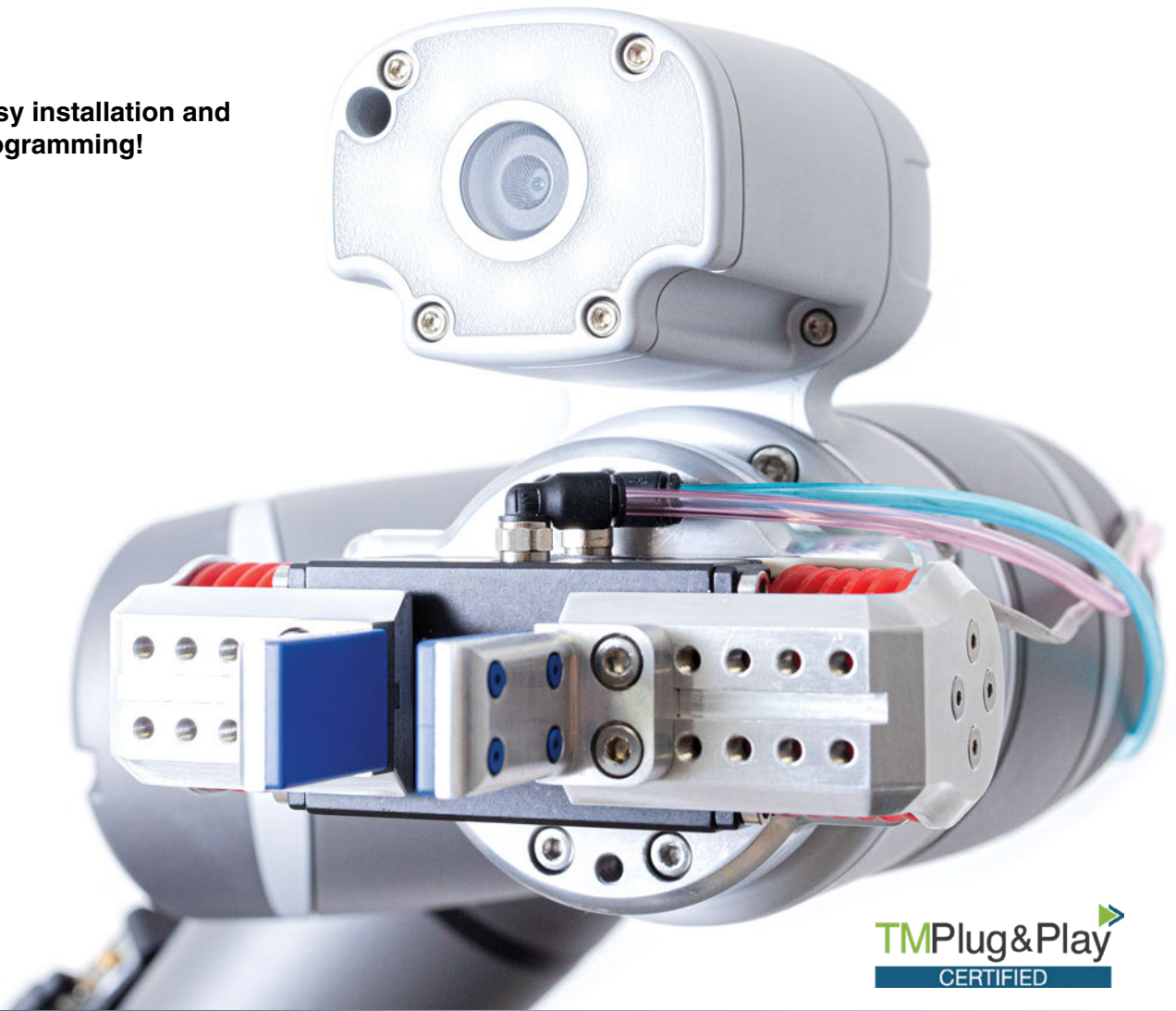

- CU
- QC
- VG
- VC
- VA
- SG
- GR**
- MT
- AC
- CS
- CC



CRK SX2520 A Gripper Kit Includes:



Quick# 8016

5/2 Solenoid valve with fittings, mufflers, and non-slip Velcro® strap.



Quick# 8015

Two cable management clamps with non-slip Velcro strap.



Alternate pads for fingers.



USB drive with robot plug-in, and user manual.



EMI Gripper Kit – 2-Jaw SX for Industrial Cobots

(Dimensioned drawing shown at 75% scale)

These diagrams show the **CRK-SX2520-A Kit**.

Information like this is found in the User Manuals supplied with each kit.

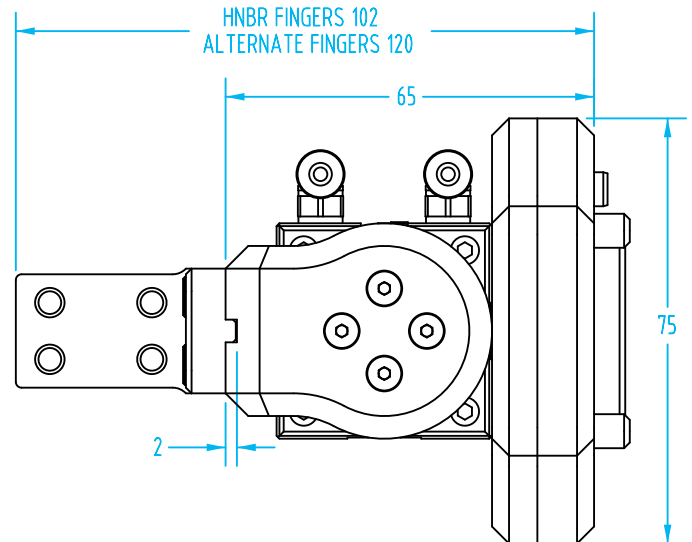
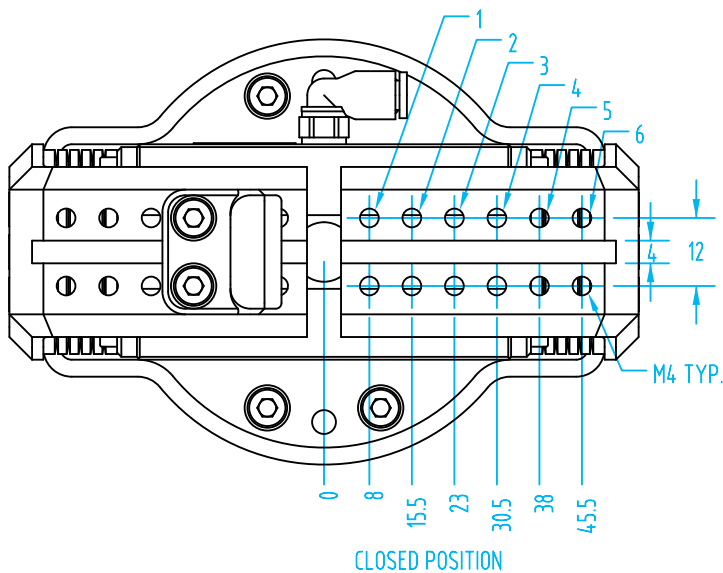
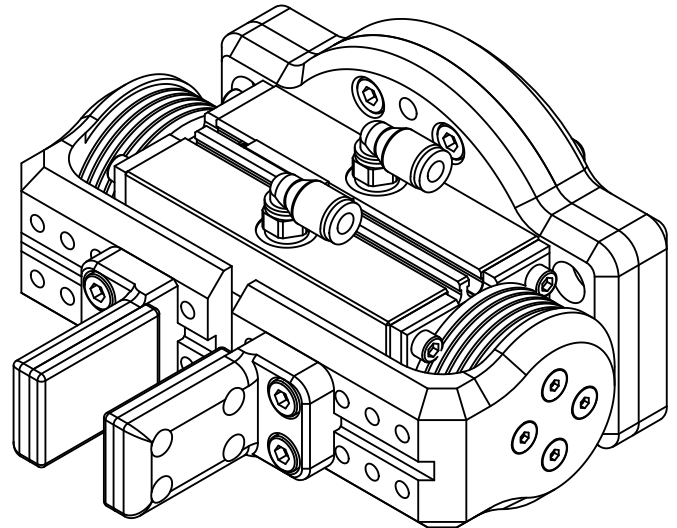
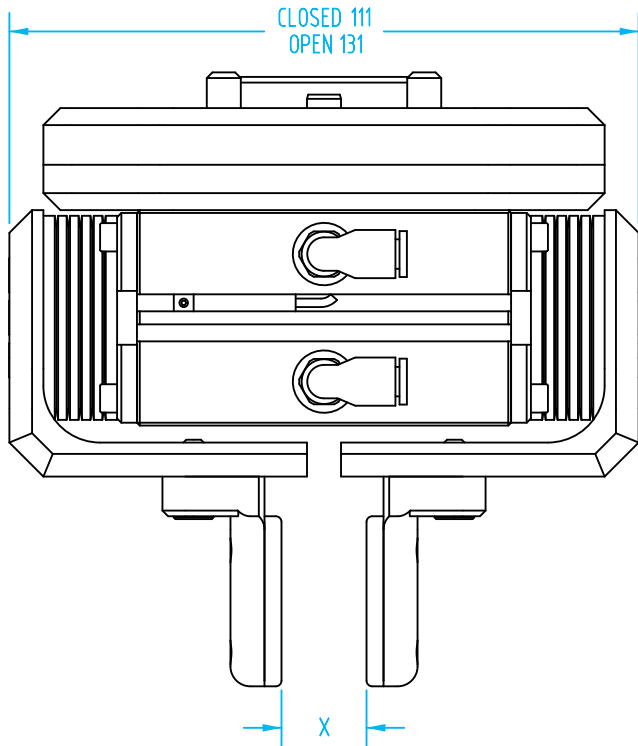

Finger Mount Position #	HNBR Finger Pads		Silicone/Rubber Finger Pads	
	CLOSED MIN (mm)	OPEN MAX (mm)	CLOSED MIN (mm)	OPEN MAX (mm)
1	0	5	0	0.8
2	0	20	0	15.8
3	15	35	10.8	30.8
4	30	50	25.8	45.8
5	45	65	40.8	60.8
6	60	80	55.8	75.8



SX Gripper Options for Industrial Cobots

All EMI gripper kits ship with components nested into a 3d printed box insert. Also included but not pictured here is a user manual, hardware and wiring packages.



Shown here is a custom kit using the SX4040 gripper for a wider gripping range with greater adjustability.

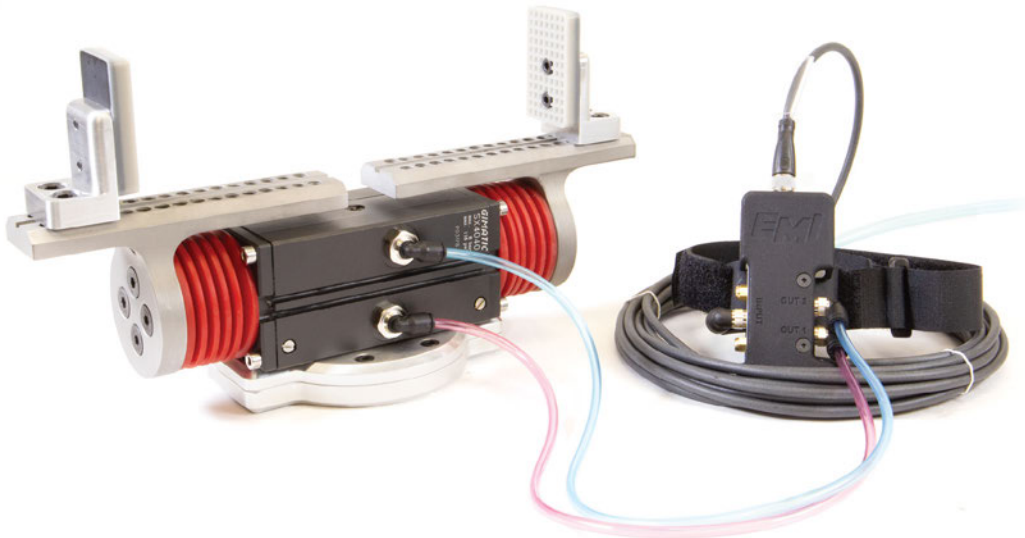

QC50 Quick Changer with SX2520 Gripper adapted to a Fanuc Collaborative Robot. All kits can be outfitted with a quick changer upon request!

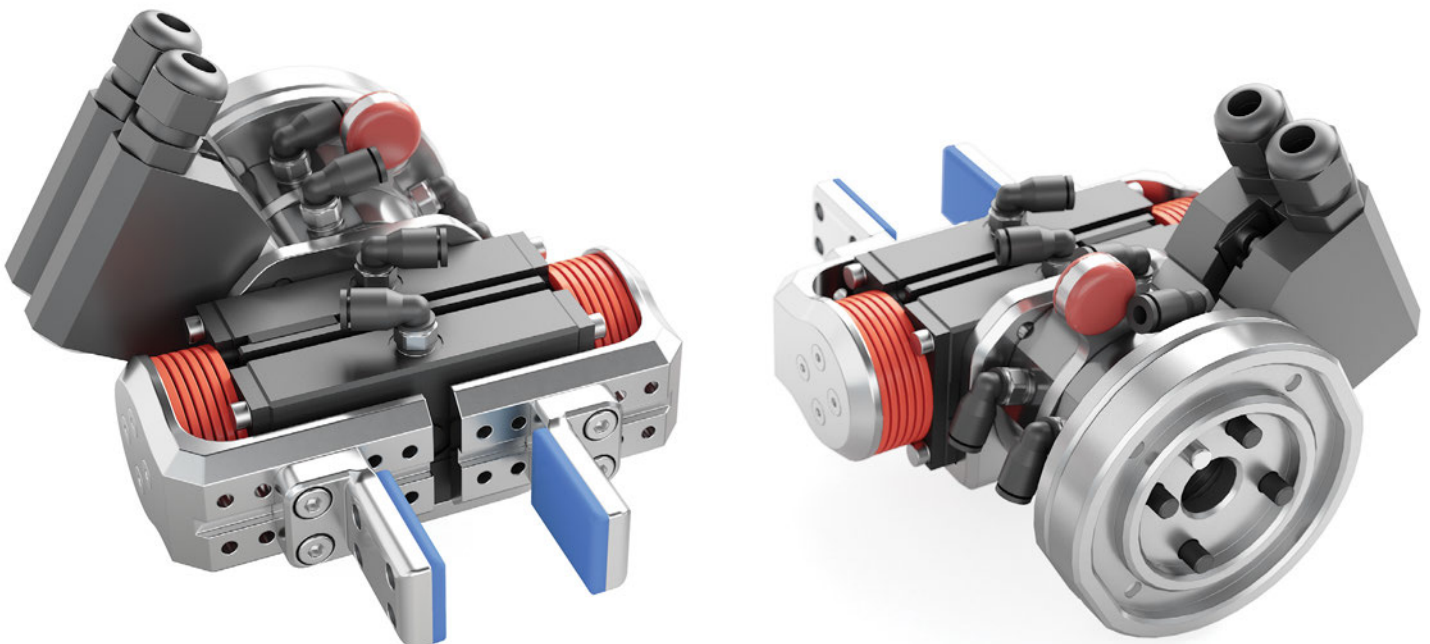

- CU
- QC
- VG
- VC
- VA
- SG
- GR**
- MT
- AC
- CS
- CC