

Vacuum Gripper – PIAB piCOBOT L



Empower your robot with this wrist-mounted vacuum powerhouse. piCOBOT®L is adaptable and will serve as the base for your next vacuum application with a mounting pattern that can be used to attach custom EOAT or standard foam grippers modules also available from EMI.



- Payload: Up to 16kg (35.2 lbs).
- Lightweight modular design.
- IP65 compliance for use in harsh environments.
- Easy maintenance.
- Powerful COAX SX42 ejectors (4x).
- Plug & Play compatible with UR and various Fanuc Robots.
- High customization potential: Piab foam grippers or EMI EOAT.

Quick#	Part#	Price	Max Vacuum Level*	Max Suction Flow*		Air Consumption*		Std. Supply Pressure		Wt
				CFM	l/min	CFM	l/min	psi	Bar	
8863	CRK-PICOBOT-L-1	\$4,346.52	89%	29.33 CFM	830 l/min	18.73 CFM	530 l/min	91.37 psi	6.3 Bar	1474g

*Values listed are achieved when supplied with the listed standard supply pressure.

Accessories / Optional Items for PIAB PICOBOT L

Quick#	Part#	Price	Description	Wt.
8864	CRV-30-180X180-FOAM	\$1,303.59	Large Gripper Module, 180x180mm, 30mm thick	672g
8865	CRV-30-420X260-FOAM	\$2,194.04	X-Large Gripper Module, 420x260mm, 30mm thick	2166g

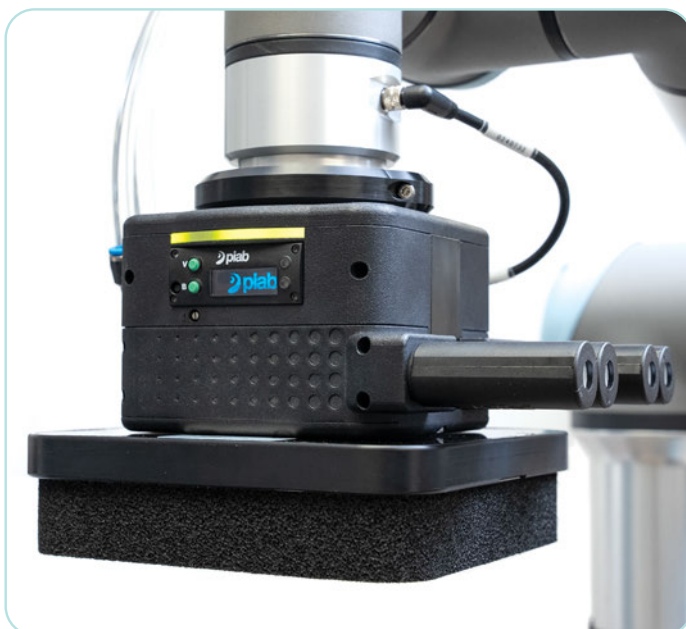

Vacuum Gripper – PIAB piCOBOT L

(Dimensioned drawings shown 50% scale)

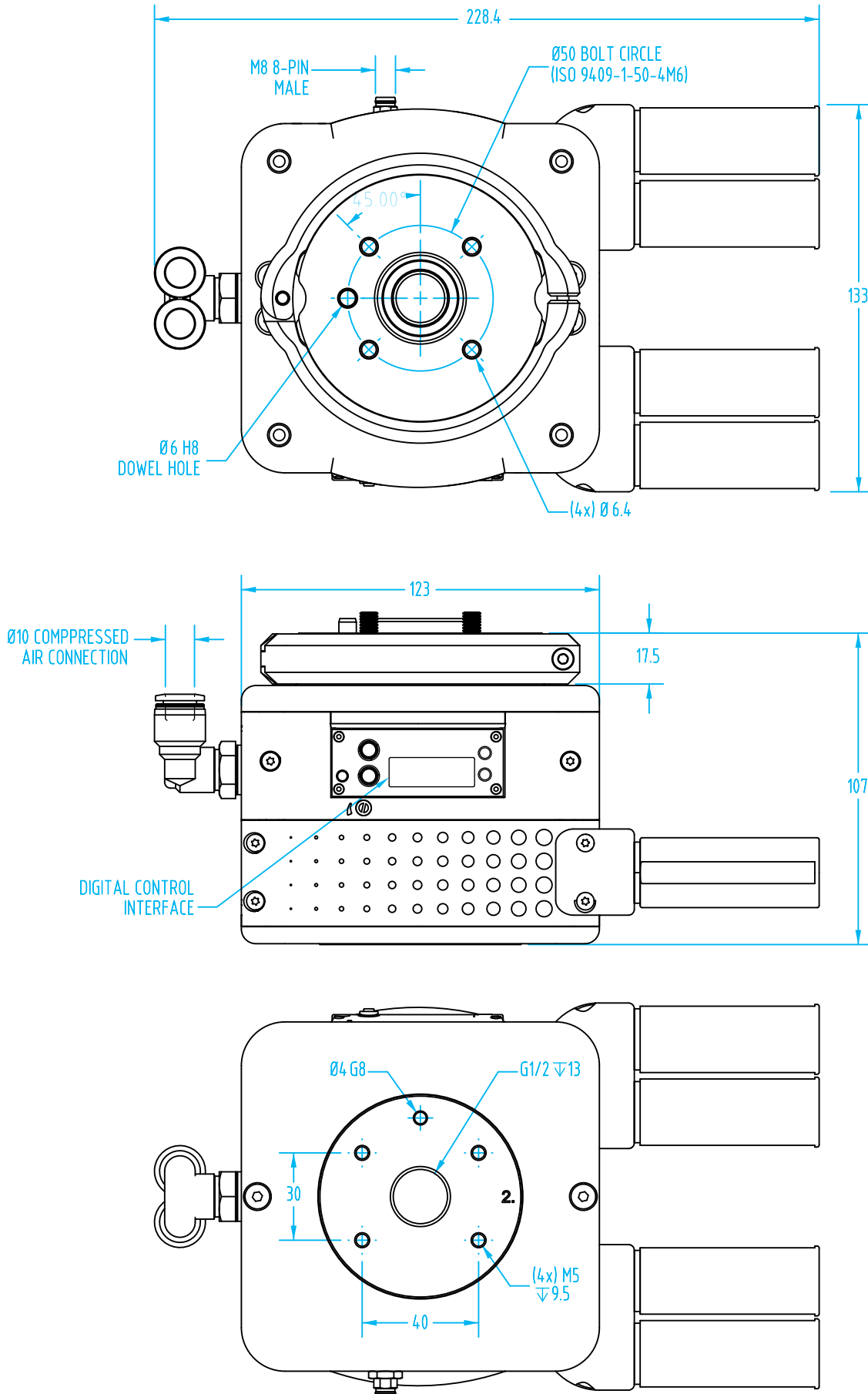

- CU
- QC
- VG
- VC
- VA
- SG
- GR
- MT
- AC
- CS
- CC