

Pneumatic tilt unit for small EOATs, series OFN

- 90° rotation.
- Single- or double-acting operation (SD).
- Several mounting accessories.
- Optional magnetic sensors, to be fitted with an SWP external clamp, or directly into the slot (SD).

OFN...	SWP...
OFN20-90	SWP-020
OFN30-90	SWP-030
OFN20-90SD	-
OFN30-90SD	-



	OFN20-90	OFN20-90SD	OFN30-90	OFN30-90SD
Medium	Compressed air in compliance with ISO 8573-1:2010 [7:4:4]			
Pressure range	2.5 ÷ 8 bar	1.5 ÷ 8 bar	2.5 ÷ 8 bar	1.5 ÷ 8 bar
Temperature range	5 ÷ 60 °C.			
Tilt angle	90°			
Cycle air consumption	3.52 cm ³	5.53 cm ³	12.9 cm ³	19.6 cm ³
Lift torque at 6 bar (90° 0°)	70 Ncm	80 Ncm	300 Ncm	300 Ncm
Drop torque at 6 bar (0° 90°)	15 Ncm	40 Ncm	30 Ncm	150 Ncm
Weight	75 g	88 g	210 g	260 g

Dimensions (mm)



	OFN20-90	OFN20-90SD	OFN30-90	OFN30-90SD
A	83	-	119	-
B	16	-	18.5	-
C	7.5	-	11	-
D	8	-	10	-
E	18.3	-	25.3	-
F	M17x1	-	M27x1	-
G	8	-	11	-
J	34	-	46	-
K	23	-	25	-
L	20	-	30	-
M	16.5	-	25	-
N	24.5	-	37	-
O	20	-	30	-
P	28.3	-	40.3	-
Q	3.3	-	5.3	-
R	6	-	10	-
S	3.3	-	5.3	-
	17	-	27	-
V	-	103.5	-	144
Z	M5	M3	M5	M5

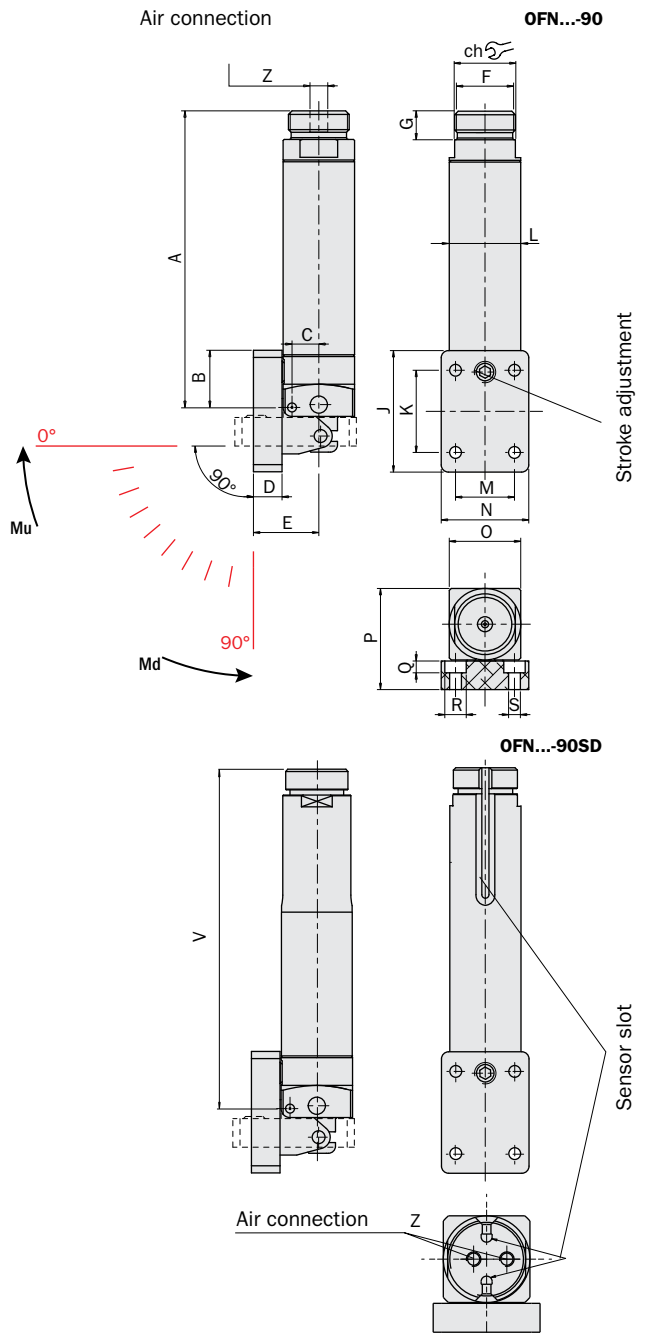

Application example

