

# Vacuum gripping systems with foam / FGS-120-SV with fine pitch and self-closing valves and solenoid valves integrated

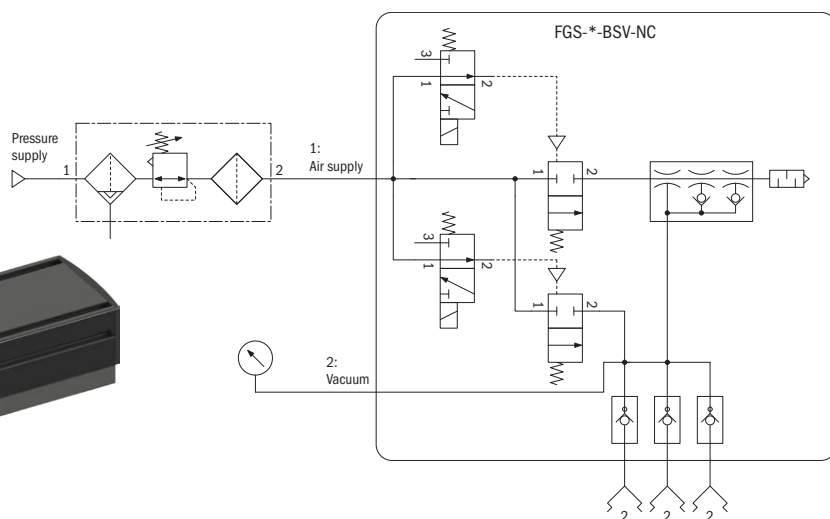

## FGS-120-0400-F20-0T-VA-BSV-NC

- The FGS-120-SV series of vacuum gripping systems, in the version with foam, is a modular and versatile solution for handling different products with different sizes, shapes and porosity
- Integrated EJ-LARGE-HF-3 multistage cartridges for high suction flow rate and low energy consumption
- The version with self-closing valves is ideal in applications where objects with different sizes/shapes need to be handled. It allows the user to work with smaller vacuum pumps, reducing consumption while maintaining a high level of vacuum, even when most of the gripper surface area is not engaged
- With ON/OFF vacuum solenoid valve with manual override control
- With ON/OFF blow-off solenoid valve with manual override control



### Technical features

Max feed pressure	0.6 MPa
Temperature range	0 ÷ +50 °C
Weight	4 kg
Material	SS, AI, EPDM, NBR, PA12
Noise level	70 dB

### Technical features of the solenoid valves

Power absorption	2.5 W (each valve)
Drive voltage	24 Vcc ±10%
Type of electrical connection	5-pin M12x1 (each side)
Manual Override	yes
IP rating	IP65

### Suction flow rate

Model	Feed pressure [MPa]	Air consumption [NI/s]	Suction flow rate [NI/s] at different vacuum levels [kPa]								Max vacuum [kPa]
			0	-10	-20	-30	-40	-50	-60	-70	
FGS-120-0400-F20-0T-VA-EJL4-BSV-NC	0.6	6.8	23.6	14	10	6.8	3.56	2.48	2.04	1.24	-73

**Gripping force**

Model	Gripping force [N] at different vacuum levels				
	-30 kPa	-40 kPa	-50 kPa	-60 kPa	-70 kPa
FGS-120-0400-F20	175	220	278	335	395

Theoretical gripping force on flat surface, with fully covered gripping surface, safety factor excluded  
 Standard foam thickness: 20 mm

**Identification codes**

Alphanumeric code	Description	Order code
FGS-120-0400-F20-OT-VA-EJL4-BSV-NC	Vacuum gripping system with foam, 120x400 mm, fine pitch, with integrated self-closing valves, NC 3/2 solenoid valve for vacuum and NC 3/2 solenoid valve for blow-off, 24 Vdc, 2.5 W (for each solenoid valve)	357010404

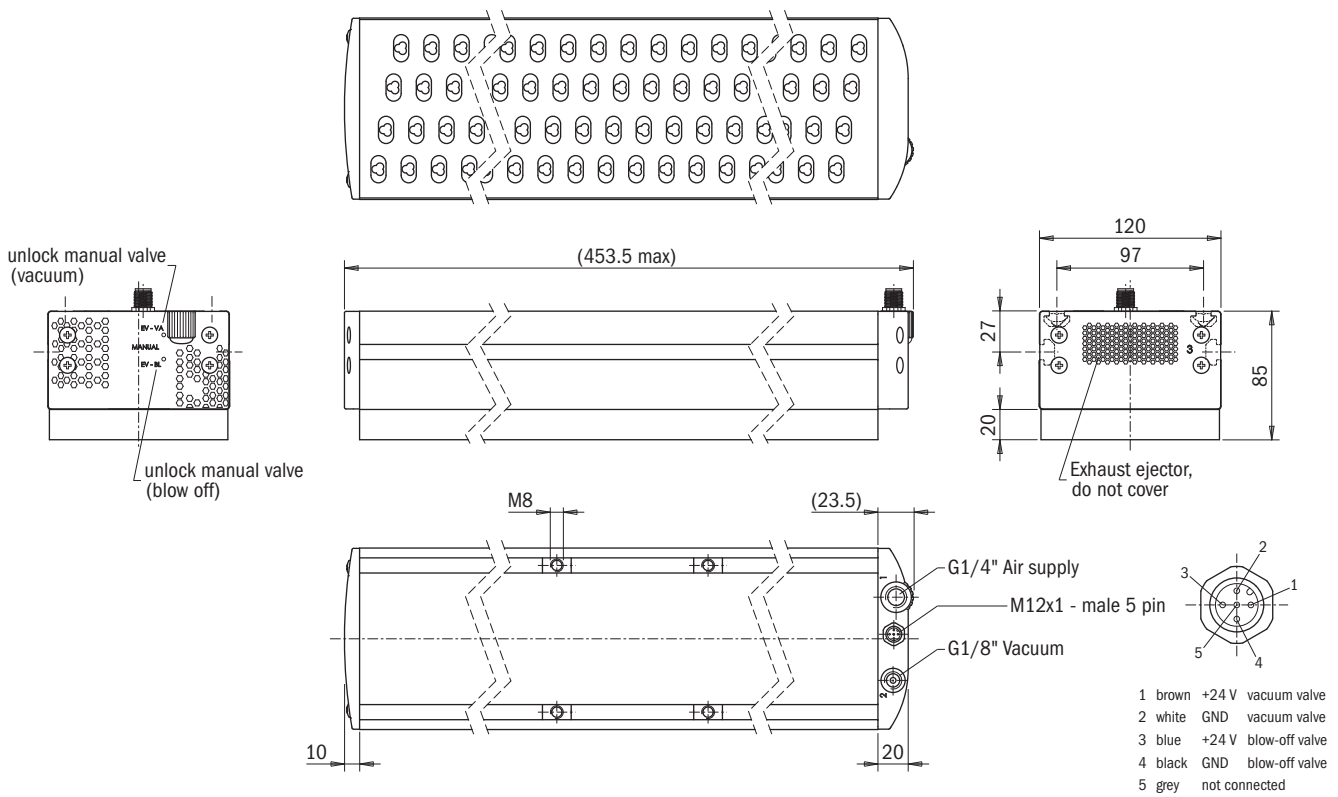

**Identification codes**

Alphanumeric code	Spare parts	Order code
FGS-120-0400-F20-OT	Spare EPDM foam, 120x200 mm, thickness 20 mm, fine pitch	353012004

