

RM Conveyor Tail Section - Exploded View

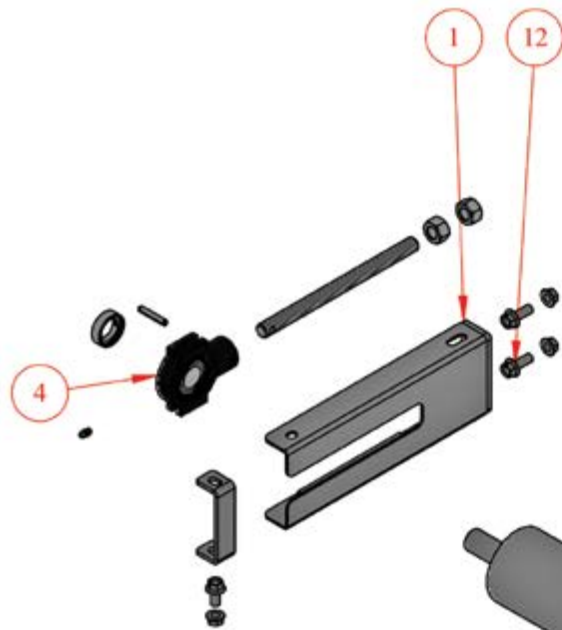

NO.	QTY.	PART NO.	DESCRIPTION
1	2	4E-258-2	TAIL/DRIVE SIDE
2	1	2E-224-2-W	TAIL PULLEY
3	2	2E-32-4	THREADED ROD
4	2	CP-822	BEARING - RUPL - 16 X 1" BORE
5	2	CP-2778	.250-28 GREASE ZERK
6	2	CP-1209	LOCKING COLLAR .500IDx1.000ODx.4375TH
7	4	CP-505	HEX NUT .625-11
8	2	CP-1360	ROLL PIN .250 x 1.500
9	2	4E-14-1	"C" CLIP
10	6	CP-2869	SERRATED FLANGE NUT 0.375-16 ZINC PLATED
11	2	CP-2890	HEX SERRATED FLANGE SCREW 0.375-16x0.750" ZINC PLATED
12	4	CP-2939	HEX SERRATED FLANGE SCREW 0.375-16x1.000" ZINC PLATED

