

EOAT Mounting Plate for Large Size Quick Changers

(Dimensioned drawing shown half scale)

Fastens to 150mm Quick Changer for Mounting of >ASS<, Gimatic, and 80/20 Profiles

Typically used when the injection molding machine is over 750 tons, this plate is designed to mount large/jumbo >ASS<, Gimatic, and 80/20 four- and six-groove profiles (80mmx40mm) as well as all standard four- and six-groove >ASS<, Gimatic, and 80/20 profiles. It is pre-drilled to mount to the large EOAT quick changer. The counter-bored holes provide flush mounting surfaces on both sides. And it can also be used as a manual mounting plate to the robot.

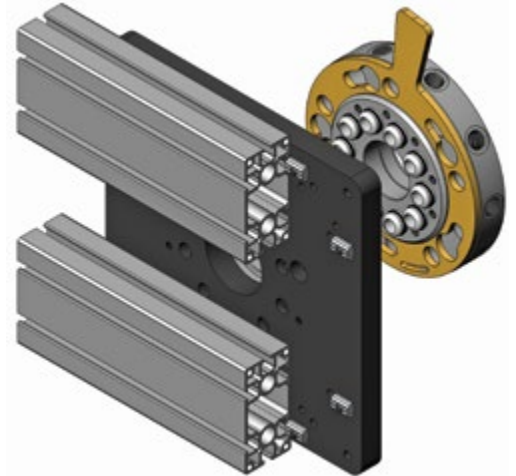

150mm EOAT Mounting Plate

Quick#	Part#	Wt.	Price	Description
1817	GSC-QCAP-L	2094g	\$78.00	Fasteners on page 1071

- Ⓐ 40mm spacing for >ASS< 80mm X 40mm "J" profiles. Use: #874 M6 x 16mm SHCS, #880 lock washer, & #3031 M6 T nut.

- Ⓑ 25mm spacing for >ASS< 50mm X 25mm "X" profiles and 80/20 1020 profiles. Use #854 M5 x 12mm SHCS, #865 lock washer, & #3030 M5 T nut.

